



HI-200, HI-201

Dual/Quad SPST, CMOS Analog Switches

FN3121  
Rev 9.00  
September 15, 2015

HI-200/HI-201 (dual/quad) are monolithic devices comprising independently selectable SPST switches which feature fast switching speeds (HI-200 240ns, and HI-201 185ns) combined with low power dissipation (15mW at 25°C). Each switch provides low "ON" resistance operation for input signal voltage up to the supply rails and for signal current up to 80mA. Rugged DI construction eliminates latch-up and substrate SCR failure modes.

All devices provide break-before-make switching and are TTL and CMOS compatible for maximum application versatility. HI-200/HI-201 are ideal components for use in high frequency analog switching. Typical applications include signal path switching, sample and hold circuit, digital filters, and operational amplifier gain switching networks.

**Ordering Information**

PART NUMBER	TEMP. RANGE (°C)	PACKAGE	PKG. DWG. #
HI3-0200-5Z (Note) (No longer available or supported)	0 to 75	14 Ld PDIP* (Pb-free)	E14.3
HI1-0201-2	-55 to 125	16 Ld CERDIP	F16.3
HI3-0201-5Z (Note)	0 to 75	16 Ld PDIP* (Pb-free)	E16.3
HI4P0201-5Z (Note) (No longer available or supported)	0 to 75	20 Ld PLCC (Pb-free)	N20.35
HI9P0201-5Z (Note)	0 to 75	16 Ld SOIC (Pb-free)	M16.15
HI9P0201-9Z (Note)	-40 to 85	16 Ld SOIC (Pb-free)	M16.15

\*Pb-free PDIPs can be used for through hole wave solder processing only. They are not intended for use in Reflow solder processing applications.

NOTE: Intersil Pb-free products employ special Pb-free material sets; molding compounds/die attach materials and 100% matte tin plate termination finish, which are RoHS compliant and compatible with both SnPb and Pb-free soldering operations. Intersil Pb-free products are MSL classified at Pb-free peak reflow temperatures that meet or exceed the Pb-free requirements of IPC/JEDEC J STD-020. Pb-free PDIPs can be used for through hole wave solder processing only. They are not intended for use in Reflow solder processing applications.

**Features**

- Pb-Free Available (RoHS Compliant)
- Analog Voltage Range . . . . . ±15V
- Analog Current Range . . . . . 80mA
- Turn-On Time . . . . . 240ns
- Low r<sub>ON</sub> . . . . . 55Ω
- Low Power Dissipation . . . . . 15mW
- TTL/CMOS Compatible

**Applications**

- High Frequency Analog Switching
- Sample and Hold Circuits
- Digital Filters
- Operational Amplifier Gain Switching Networks

**Functional Diagram**

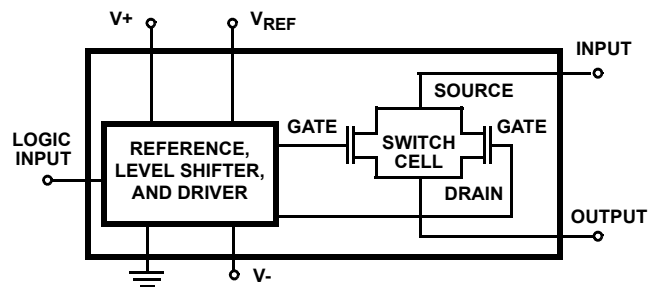

TRUTH TABLE

LOGIC	HI-200	HI-201
0	ON	ON
1	OFF	OFF

**Pinouts** (Switches Shown For Logic "1" Input)

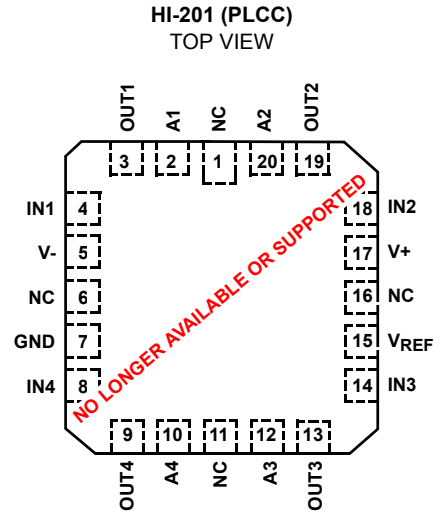
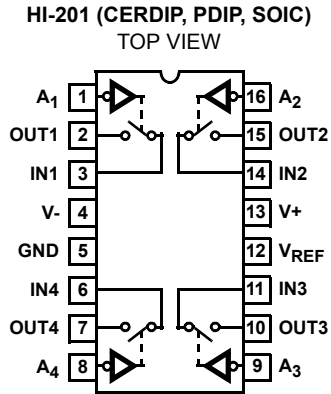
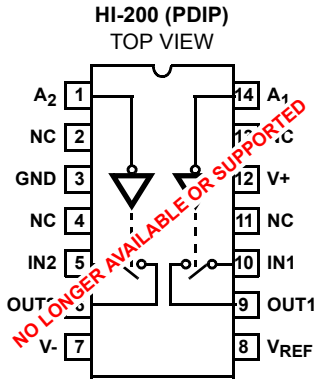

**Schematic Diagrams**

TTL/CMOS REFERENCE CIRCUIT  $V_{REF}$  CELL  
HI-200

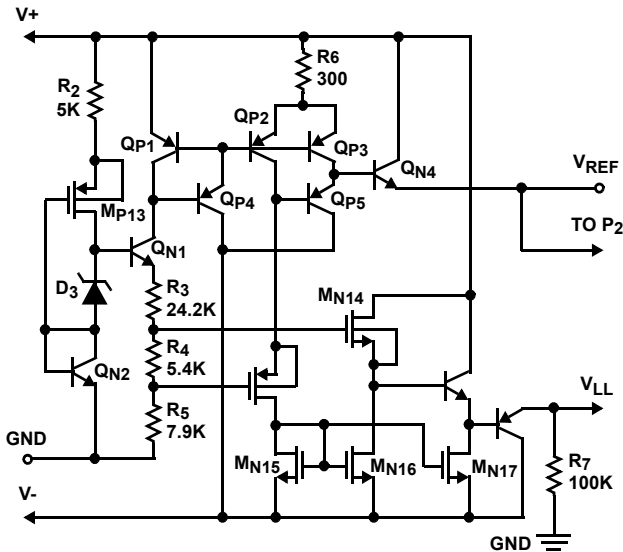

TTL/CMOS REFERENCE CIRCUIT  $V_{REF}$  CELL  
HI-201

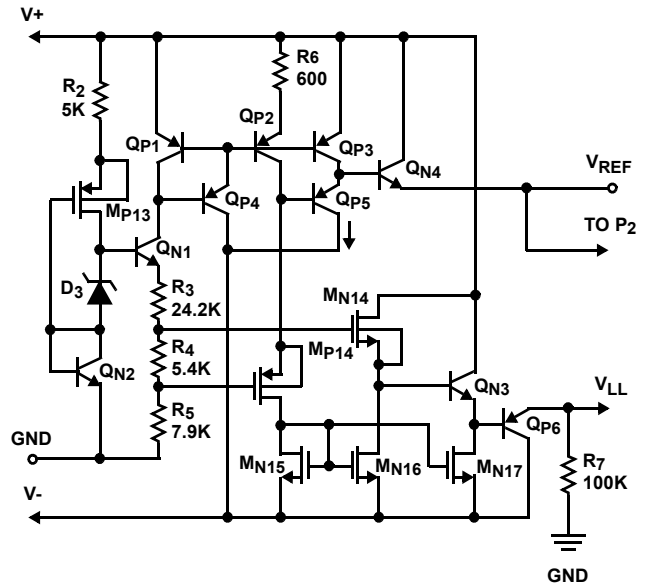

**Schematic Diagrams** (Continued)

**SWITCH CELL**

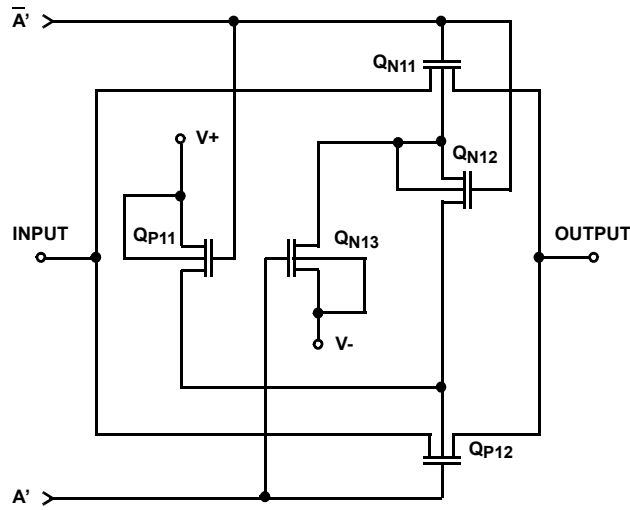

**DIGITAL INPUT BUFFER AND LEVEL SHIFTER**

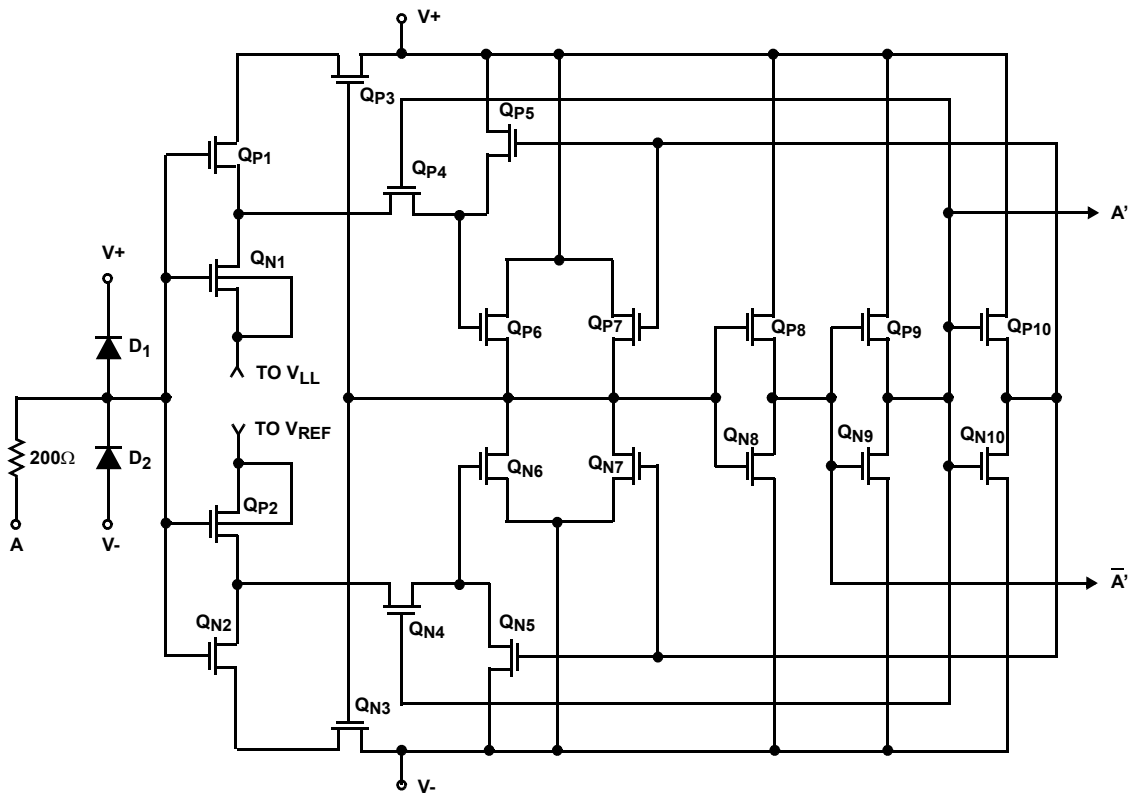

### Absolute Maximum Ratings

Supply Voltage (V+ to V-)	44V (±22)
V <sub>REF</sub> to Ground	20V, -5V
Digital Input Voltage	(V+) +4V to (V-) -4V
Analog Input Voltage (One Switch)	(V+) +2V to (V-) -2V

### Operating Conditions

Temperature Ranges	
HI-201-2	-55°C to 125°C
HI-201-4	-25°C to 85°C
HI-200-5, HI-201-5	0°C to 75°C
HI-201-9	-40°C to 85°C

### Thermal Information

Thermal Resistance (Typical, Note 1)	$\theta_{JA}$ (°C/W)	$\theta_{JC}$ (°C/W)
CERDIP Package	75	20
PLCC Package	80	N/A
PDIP Package*	95	N/A
SOIC Package	110	N/A
Maximum Storage Temperature	-65°C to 150°C	
Maximum Junction Temperature (Hermetic Packages)	175°C	
Maximum Junction Temperature (Plastic Packages)	150°C	
Maximum Lead Temperature (Soldering, 10s)	300°C (PLCC and SOIC - Lead Tips Only)	

\*Pb-free PDIPs can be used for through hole wave solder processing only. They are not intended for use in reflow solder processing applications.

**CAUTION:** Stresses above those listed in "Absolute Maximum Ratings" may cause permanent damage to the device. This is a stress only rating and operation of the device at these or any other conditions above those indicated in the operational sections of this specification is not implied.

**NOTE:**

1.  $\theta_{JA}$  is measured with the component mounted on an evaluation PC board in free air.

### Electrical Specifications

Supplies = +15V, -15V; V<sub>REF</sub> = Open; V<sub>AH</sub> (Logic Level High) = 2.4V, V<sub>AL</sub> (Logic Level Low) = 0.8V

PARAMETER	TEST CONDITIONS	TEMP (°C)	-2			-4, -5, -9			UNITS
			MIN	TYP	MAX	MIN	TYP	MAX	
<b>DYNAMIC CHARACTERISTICS</b>									
Switch ON Time, t <sub>ON</sub>									
HI-200		25	-	240	500	-	240	-	ns
HI-201		25	-	185	500	-	185	-	ns
		Full	-	1000	-	-	1000	-	ns
Switch OFF Time, t <sub>OFF</sub>									
HI-200		25	-	330	500	-	500	-	ns
HI-201		25	-	220	500	-	220	-	ns
		Full	-	1000	-	-	1000	-	ns
Off Isolation	(Note 4)								
HI-200		25	-	70	-	-	70	-	dB
HI-201		25	-	80	-	-	80	-	dB
Input Switch Capacitance, C <sub>S(OFF)</sub>		25	-	5.5	-	-	5.5	-	pF
Output Switch Capacitance, C <sub>D(OFF)</sub>		25	-	5.5	-	-	5.5	-	pF
Output Switch Capacitance, C <sub>D(ON)</sub>		25	-	11	-	-	11	-	pF
Digital Input Capacitance, C <sub>A</sub>		25	-	5	-	-	5	-	pF
Drain-to-Source Capacitance, C <sub>DS(OFF)</sub>		25	-	0.5	-	-	0.5	-	pF
<b>DIGITAL INPUT CHARACTERISTICS</b>									
Input Low Threshold, V <sub>AL</sub>		Full	-	-	0.8	-	-	0.8	V
Input High Threshold, V <sub>AH</sub>		Full	2.4	-	-	2.4	-	-	V
Input Leakage Current (High or Low), I <sub>A</sub>	(Note 3)	Full	-	-	1.0	-	-	1.0	μA
<b>ANALOG SWITCH CHARACTERISTICS</b>									
Analog Signal Range, V <sub>S</sub>		Full	-15	-	+15	-15	-	+15	V
ON Resistance, r <sub>ON</sub>	(Note 2)	25	-	55	70	-	55	80	Ω
		Full	-	80	100	-	72	100	Ω

**Electrical Specifications** Supplies = +15V, -15V; V<sub>REF</sub> = Open; V<sub>AH</sub> (Logic Level High) = 2.4V, V<sub>AL</sub> (Logic Level Low) = 0.8V (Continued)

PARAMETER	TEST CONDITIONS	TEMP (°C)	-2			-4, -5, -9			UNITS
			MIN	TYP	MAX	MIN	TYP	MAX	
OFF Input Leakage Current, I <sub>S(OFF)</sub>	(Note 6)	25	-	1	5	-	1	50	nA
		Full	-	100	500	-	10	500	nA
		25	-	2	5	-	2	50	nA
		Full	-	-	500	-	-	250	nA
OFF Output Leakage Current, I <sub>D(OFF)</sub>	(Note 6)	25	-	1	5	-	1	50	nA
		Full	-	100	500	-	10	500	nA
		25	-	2	5	-	2	50	nA
		Full	-	35	500	-	35	250	nA
ON Leakage Current, I <sub>D(ON)</sub>	(Note 6)	25	-	1	5	-	1	50	nA
		Full	-	100	500	-	10	500	nA
		25	-	2	5	-	2	50	nA
		Full	-	-	500	-	-	250	nA
<b>POWER SUPPLY CHARACTERISTICS</b> (Note 5)									
Power Dissipation, P <sub>D</sub>		25	-	15	-	-	15	-	mW
		Full	-	-	60	-	-	60	mW
Current, I <sub>+</sub>		25	-	0.5	-	-	0.5	-	mA
		Full	-	-	2.0	-	-	2.0	mA
Current, I <sub>-</sub>		25	-	0.5	-	-	0.5	-	mA
		Full	-	-	2.0	-	-	2.0	mA

NOTES:

- V<sub>OUT</sub> = ±10V, I<sub>OUT</sub> = 1mA.
- Digital Inputs are MOS gates: typical leakage is < 1nA.
- V<sub>A</sub> = 5V, R<sub>L</sub> = 1kΩ, C<sub>L</sub> = 10pF, V<sub>S</sub> = 3V<sub>RMS</sub>, f = 100kHz.
- V<sub>A</sub> = +3V or V<sub>A</sub> = 0V for Both Switches.
- V<sub>A</sub> = +3V or V<sub>A</sub> = 0V for Both Switches.
- Refer to Leakage Current Measurements (Figure 2).

**Test Circuits and Waveforms** T<sub>A</sub> = 25°C, V<sub>SUPPLY</sub> = ±15V, V<sub>AH</sub> = 2.4V, V<sub>AL</sub> = 0.8V and V<sub>REF</sub> = Open

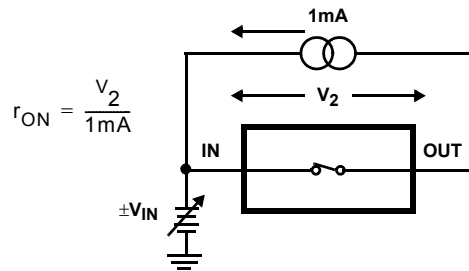

FIGURE 1A. ON RESISTANCE TEST CIRCUIT

**Test Circuits and Waveforms**  $T_A = 25^\circ\text{C}$ ,  $V_{\text{SUPPLY}} = \pm 15\text{V}$ ,  $V_{\text{AH}} = 2.4\text{V}$ ,  $V_{\text{AL}} = 0.8\text{V}$  and  $V_{\text{REF}} = \text{Open}$  (Continued)

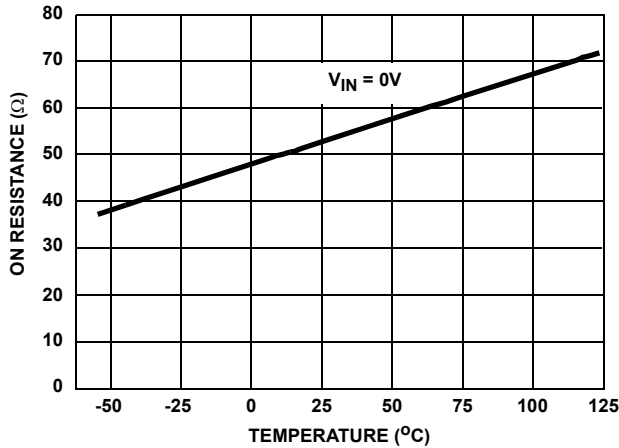

FIGURE 1B. ON RESISTANCE vs TEMPERATURE

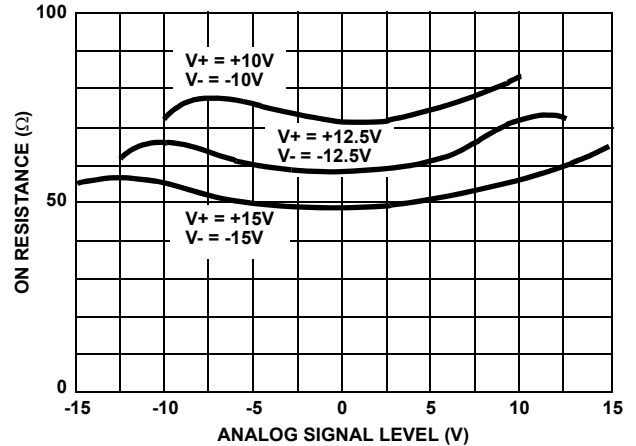

FIGURE 1C. HI-200 ON RESISTANCE vs ANALOG SIGNAL LEVEL

FIGURE 1. ON RESISTANCE

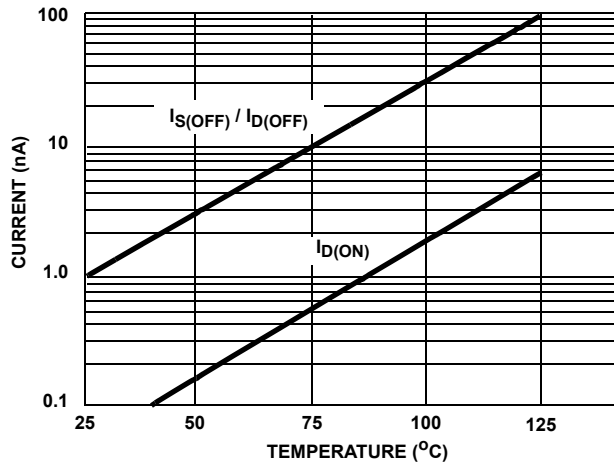

FIGURE 2A. LEAKAGE CURRENT vs TEMPERATURE

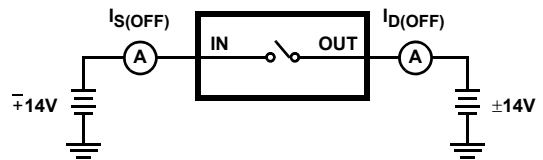

FIGURE 2B. OFF LEAKAGE CURRENT TEST CIRCUIT

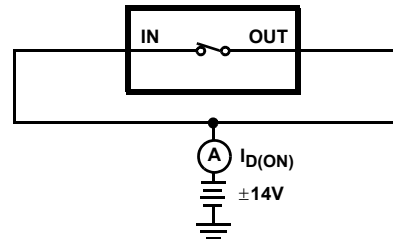

FIGURE 2C. ON LEAKAGE CURRENT TEST CIRCUIT

FIGURE 2. LEAKAGE CURRENTS

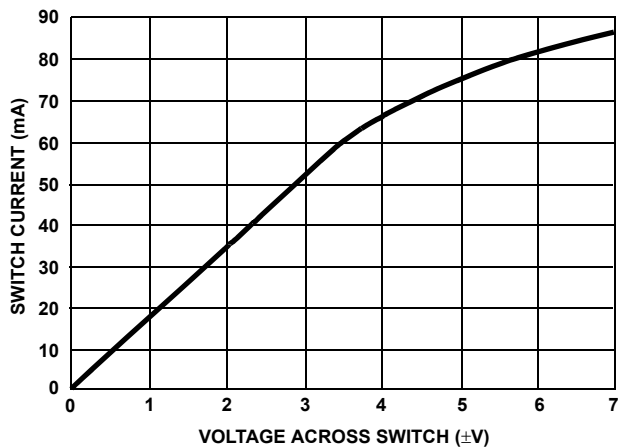

FIGURE 3A. SWITCH CURRENT vs VOLTAGE

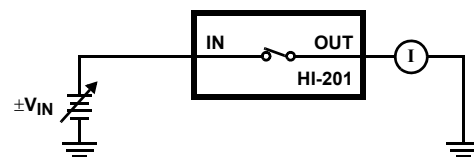

FIGURE 3B. TEST CIRCUIT

FIGURE 3. SWITCH CURRENT

**Test Circuits and Waveforms**  $T_A = 25^{\circ}\text{C}$ ,  $V_{\text{SUPPLY}} = \pm 15\text{V}$ ,  $V_{\text{AH}} = 2.4\text{V}$ ,  $V_{\text{AL}} = 0.8\text{V}$  and  $V_{\text{REF}} = \text{Open}$  (Continued)

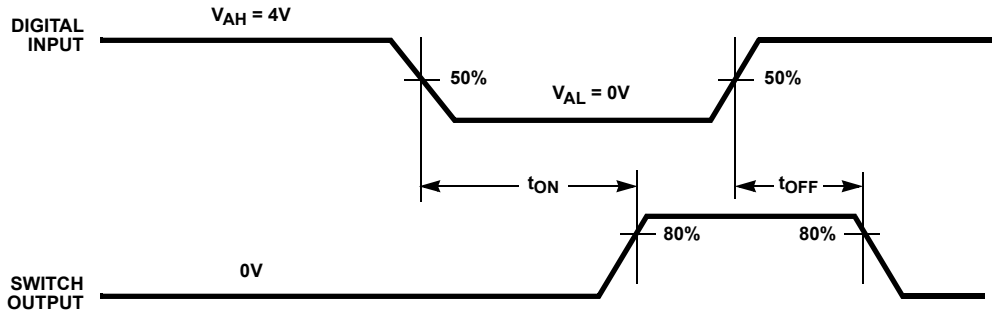
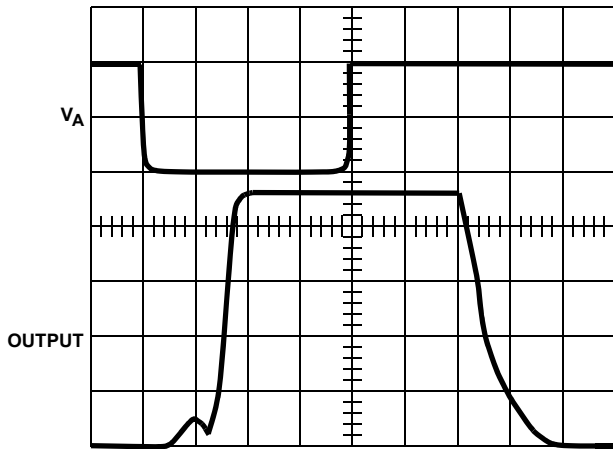
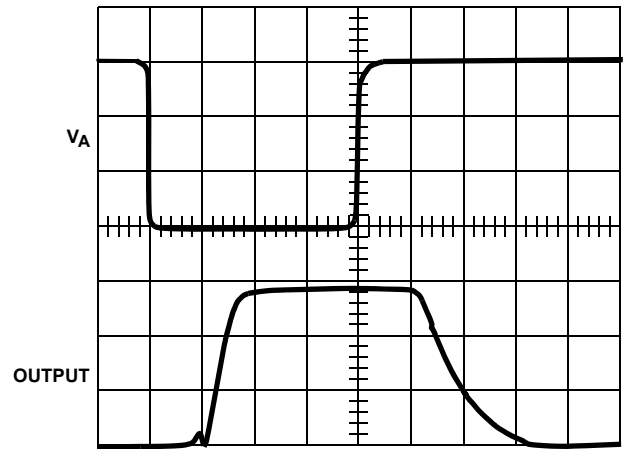

FIGURE 4A. MEASUREMENT POINTS



$V_A = 0$  to  $4\text{V}$   
Vertical:  $2\text{V}/\text{Div.}$   
Horizontal:  $100\text{ns}/\text{Div.}$

FIGURE 4B. WAVEFORMS WITH TTL COMPATIBLE LOGIC INPUT



$V_A = 0$  to  $15\text{V}$   
Vertical:  $5\text{V}/\text{Div.}$   
Horizontal:  $100\text{ns}/\text{Div.}$

FIGURE 4C. WAVEFORMS WITH CMOS COMPATIBLE LOGIC INPUT

FIGURE 4. SWITCH  $t_{\text{ON}}$  AND  $t_{\text{OFF}}$

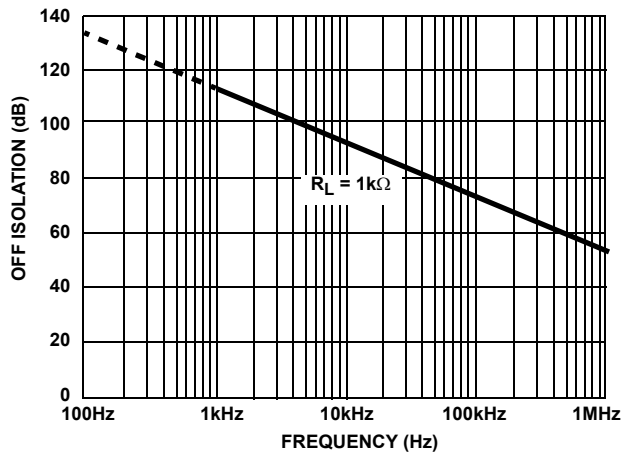

FIGURE 5. HI-201 OFF ISOLATION vs FREQUENCY

For more information see Application Notes AN520, AN521, AN531, AN532 and AN557.

## ***Application Information***

### ***Single Supply Operation***

The switch operation of the HI-200/201 is dependent upon an internally generated switching threshold voltage optimized for  $\pm 15\text{V}$  power supplies. The HI-200/201 does not provide the necessary internal switching threshold in a single supply system. Therefore, if single supply operation is required, the HI-300 series of switches is recommended. The HI-300 series will remain operational to a minimum +5V single supply.

Switch performance will degrade as power supply voltage is reduced from optimum levels ( $\pm 15\text{V}$ ). So it is recommended that a single supply design be thoroughly evaluated to ensure that the switch will meet the requirements of the application.

For further information see Application Notes AN520, AN557, AN1033 and AN1034.



### Die Characteristics

**METALLIZATION:**

Type: CuAl  
Thickness: 16kÅ ±2kÅ

**PASSIVATION:**

Type: Nitride over Silox  
Nitride Thickness: 3.5kÅ ±1kÅ  
Silox Thickness: 12kÅ ±2kÅ

**WORST CASE CURRENT DENSITY:**

2 x 10<sup>5</sup> A/cm<sup>2</sup> at 25mA

### Metallization Mask Layout

HI-201

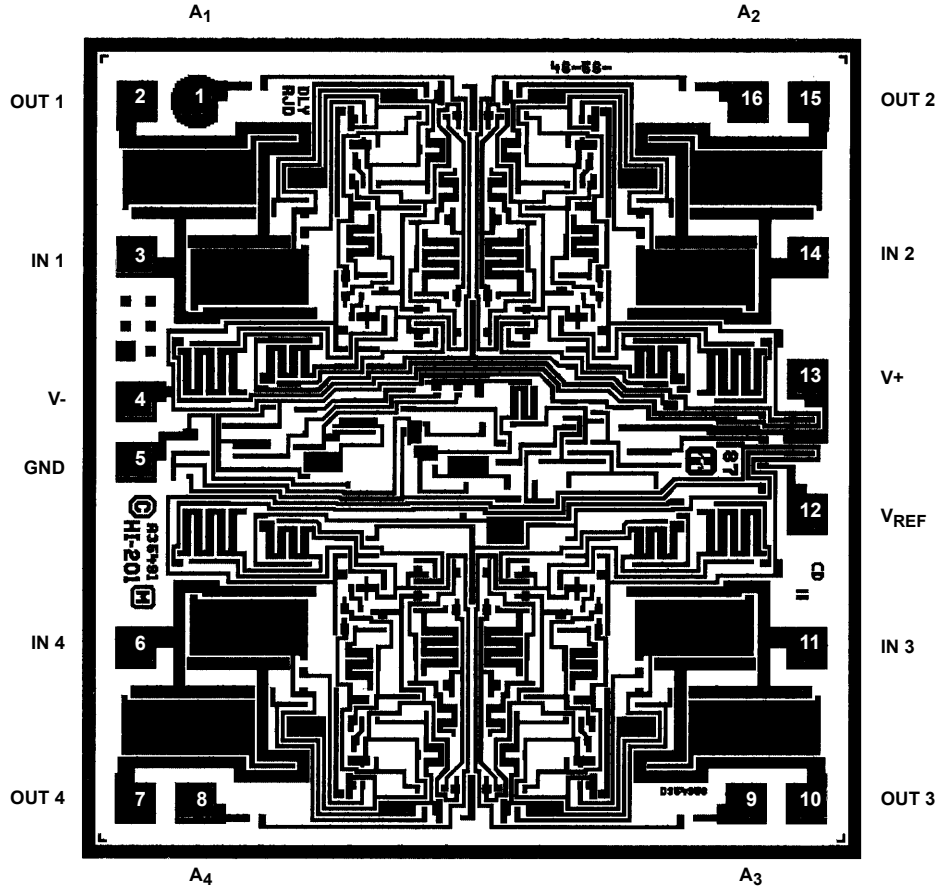

© Copyright Intersil Americas LLC 1999-2015. All Rights Reserved.  
All trademarks and registered trademarks are the property of their respective owners.

For additional products, see [www.intersil.com/en/products.html](http://www.intersil.com/en/products.html)

Intersil products are manufactured, assembled and tested utilizing ISO9001 quality systems as noted in the quality certifications found at [www.intersil.com/en/support/qualandreliability.html](http://www.intersil.com/en/support/qualandreliability.html)

*Intersil products are sold by description only. Intersil may modify the circuit design and/or specifications of products at any time without notice, provided that such modification does not, in Intersil's sole judgment, affect the form, fit or function of the product. Accordingly, the reader is cautioned to verify that datasheets are current before placing orders. Information furnished by Intersil is believed to be accurate and reliable. However, no responsibility is assumed by Intersil or its subsidiaries for its use; nor for any infringements of patents or other rights of third parties which may result from its use. No license is granted by implication or otherwise under any patent or patent rights of Intersil or its subsidiaries.*

For information regarding Intersil Corporation and its products, see [www.intersil.com](http://www.intersil.com)

### **Revision History**

The revision history provided is for informational purposes only and is believed to be accurate, but not warranted. Please go to the web to make sure that you have the latest revision.

DATE	REVISION	CHANGE
September 15, 2015	FN3121.9	- Updated Ordering Information Table on page 1. - Added Revision History. - Added About Intersil Verbiage.

---

### **About Intersil**

Intersil Corporation is a leading provider of innovative power management and precision analog solutions. The company's products address some of the largest markets within the industrial and infrastructure, mobile computing and high-end consumer markets.

For the most updated datasheet, application notes, related documentation and related parts, please see the respective product information page found at [www.intersil.com](http://www.intersil.com).

You may report errors or suggestions for improving this datasheet by visiting [www.intersil.com/ask](http://www.intersil.com/ask).

Reliability reports are also available from our website at [www.intersil.com/support](http://www.intersil.com/support).

## Looking for pricing, stock, or lifecycle information?

Click below to explore more details on WIN SOURCE:

 [View I1-0201-5 on WIN SOURCE](#)

 [Intersil Information](#)

## Optimize Your Supply Chain with WIN SOURCE Solutions

-  Global Sourcing Solution
-  Obsolete Management
-  Cost Control Management
-  Shortage Management
-  Alternative Solution
-  Excess Inventory Management