



**THE DATASHEET OF
HX5401NL**



GIGABIT (10/100/1000 BASE-T QUAD- & DUAL-TRANSFORMER MODULES AND UNFILTERED CONNECTORS

Designed to Support PoE, Auto MDIX

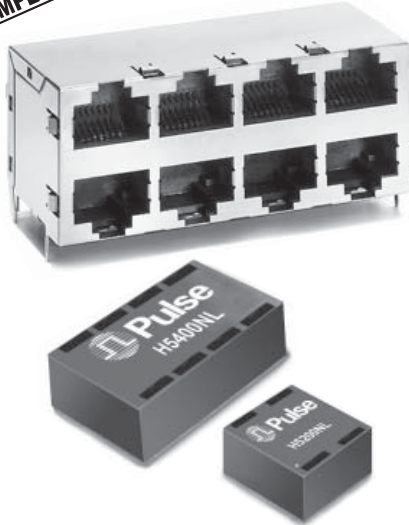

- ⚙ World's smallest Gigabit Quad- and Dual-isolation transformer modules
- ⚙ All pairs are symmetrical and balanced
- ⚙ Reliable surface mount ball grid array
- ⚙ Compact footprint, reduced board space
- ⚙ Designed to fit behind 2x2 connectors
- ⚙ RoHS-6 peak reflow temperature rating 245°C

Electrical Specifications @ 25°C — Operating Temperature 0°C to 70°C

RoHS-6 Compliant Part Number	Number of Ports	Insertion Loss (dB MAX)	Return Loss (dB MIN)					Differential to Common Mode Rejection (dB MIN)			Crosstalk (dB MIN)			Hipot (Vrms)
			1-100 MHz	1-30 MHz	40 MHz	50 MHz	60-80 MHz	100 MHz	30 MHz	60 MHz	100 MHz	30 MHz	60 MHz	
H5200NL	2	1	-18	-18	-16	-12	-10	-43	-37	-33	-43	-37	-33	1500
H5201NL	2	1	-18	-18	-16	-12	-10	-43	-37	-33	-43	-37	-33	1500
H5400NL	4	1	-18	-18	-16	-12	-10	-43	-37	-33	-43	-37	-33	1500
H5401NL	4	1	-18	-18	-16	-12	-10	-43	-37	-33	-43	-37	-33	1500
HX5200NL	2	1	-18	-18	-16	-12	-10	-43	-37	-33	-43	-37	-33	1500
HX5201NL	2	1	-18	-18	-16	-12	-10	-43	-37	-33	-43	-37	-33	1500
HX5400NL	4	1	-18	-18	-16	-12	-10	-43	-37	-33	-43	-37	-33	1500
HX5401NL	4	1	-18	-18	-16	-12	-10	-43	-37	-33	-43	-37	-33	1500

1. MSL = Moisture Sensitivity Level: 1
2. Second level mechanical shock test, mounted to 4 layer FR-4 PCB (passed 500g in 5-axis)
3. HX = operating temperature: -40°C to +85°C (extended temperature)

Connector Mechanical Specifications--Operating Temperature -40°C to 85°C

RoHS-6	Mounting, Tab Position	Number of Ports	Package Dimensions L/W/H (mm)	Solder Temperature (35 seconds)	LED Option	Plating
E6588-22A225-L	THT, Tab Down	1x2	31.24 / 21.35 / 13.6	230°C - 250°C	No LED's	Gold Plating Over Nickel
E6588-22C244-L	THT, Tab Down	1x4	59.18 / 21.35 / 13.6	230°C - 250°C	No LED's	Gold Plating Over Nickel
E6588-A5N125-L	THT, Tab Up/Down	2x2	25.35 / 31.24 / 25.3	230°C - 250°C	No LED's	Gold Plating Over Nickel
E6588-A59125-L	THT, Tab Up/Down	2x4	59.18 / 28.35 / 25.3	230°C - 250°C	No LED's	Gold Plating Over Nickel

GIGABIT (10/100/1000 BASE-T QUAD- & DUAL-TRANSFORMER MODULES AND UNFILTERED CONNECTORS

Designed to Support PoE, Auto MDIX



Mechanicals

H5400NL, H5401NL, HX5400NL, HX5401NL

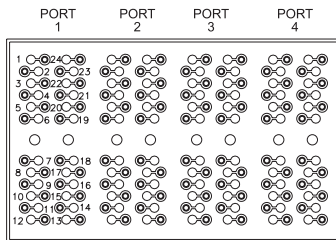
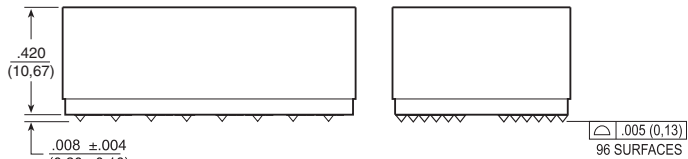
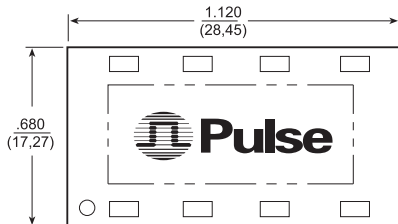

PIN NUMBERING
BOTTOM VIEW

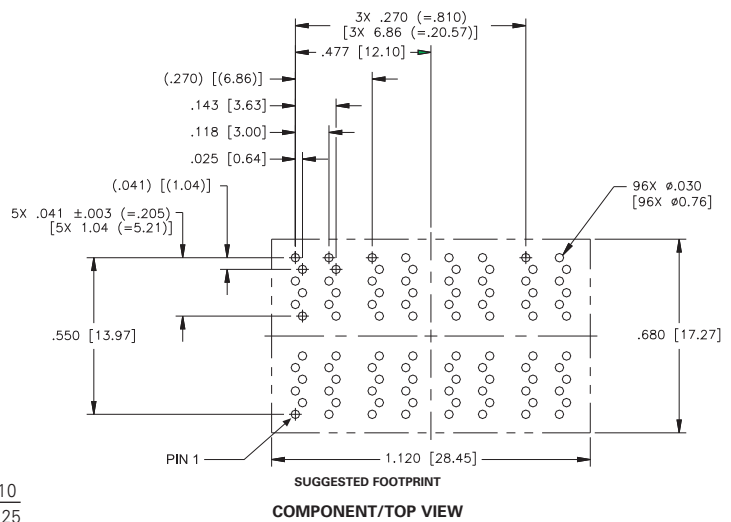

Weight 10 grams

Tray 300

Dimensions: $\frac{\text{Inches}}{\text{mm}}$ Unless otherwise specified, all tolerances are $\pm \frac{.010}{0,25}$

H5200NL, H5201NL, HX5200NL, HX5201NL

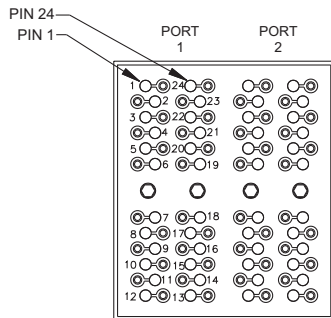
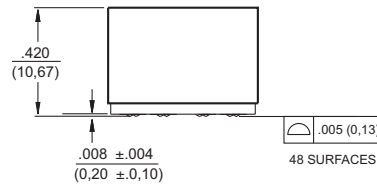
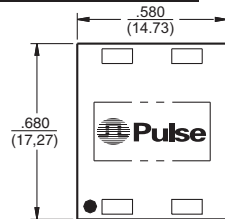

PIN NUMBERING
BOTTOM VIEW

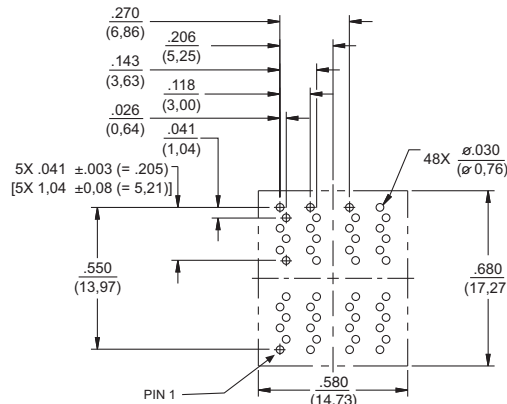

Weight 5 grams

Tray 600

Dimensions: $\frac{\text{Inches}}{\text{mm}}$ Unless otherwise specified, all tolerances are $\pm \frac{.010}{0,25}$

GIGABIT (10/100/1000 BASE-T QUAD- & DUAL-TRANSFORMER MODULES AND UNFILTERED CONNECTORS

Designed to Support PoE, Auto MDIX



Schematics

H5400NL, HX5400NL

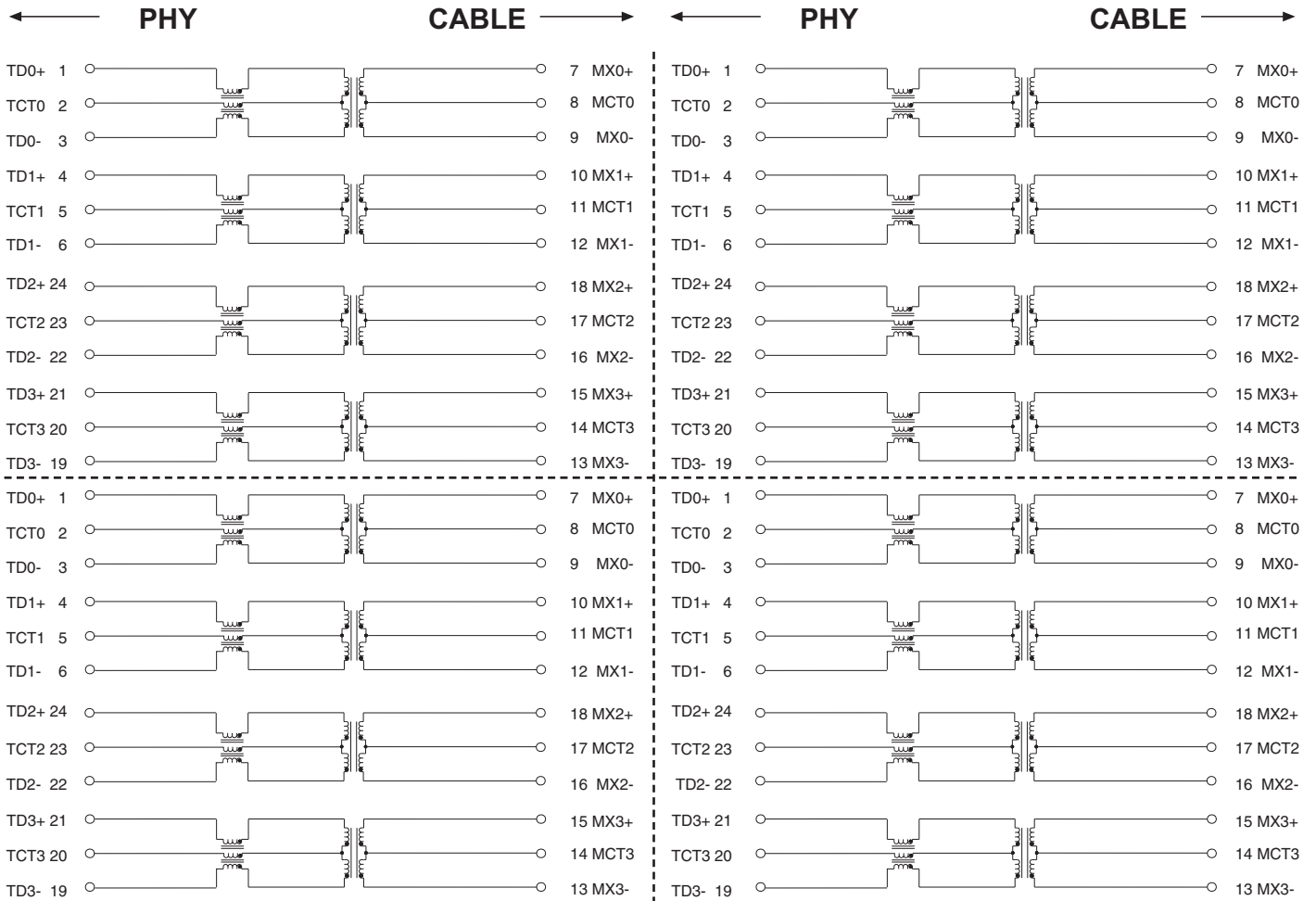

Schematics for quad ports

GIGABIT (10/100/1000 BASE-T QUAD- & DUAL-TRANSFORMER MODULES AND UNFILTERED CONNECTORS

Designed to Support PoE, Auto MDIX



Schematics (continued)

H5401NL, HX5401NL

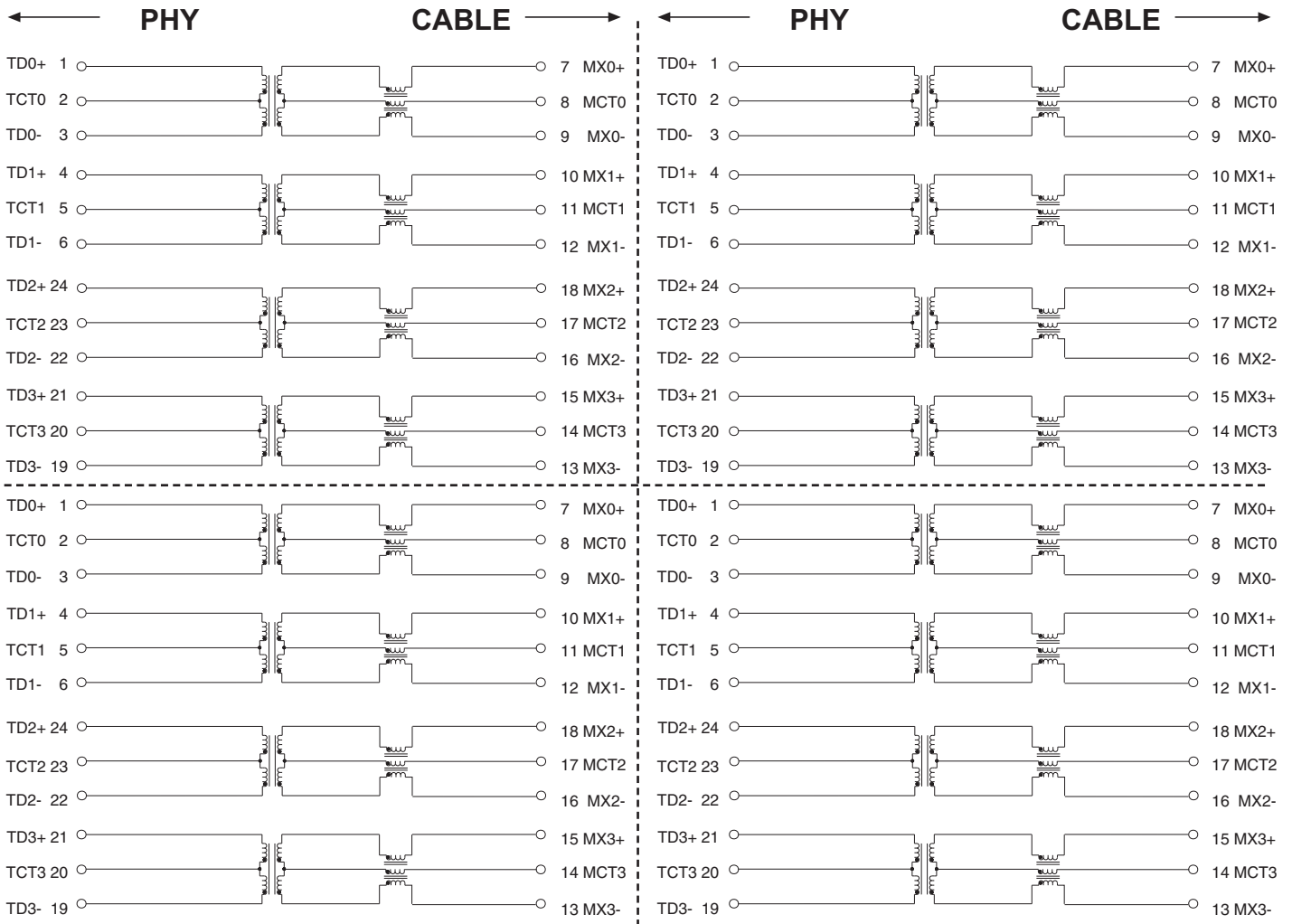

Schematics for quad ports

GIGABIT (10/100/1000 BASE-T QUAD- & DUAL-TRANSFORMER MODULES AND UNFILTERED CONNECTORS

Designed to Support PoE, Auto MDIX



Schematics (continued)

H5200NL, HX5200NL

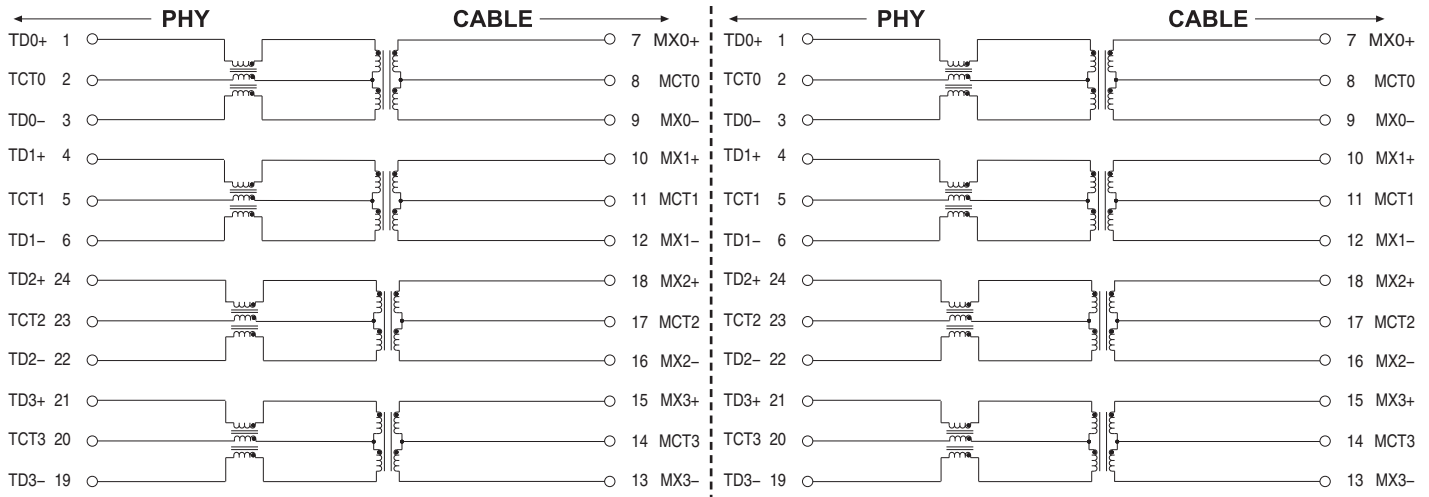

Schematics for dual ports

H5201NL, HX5201NL

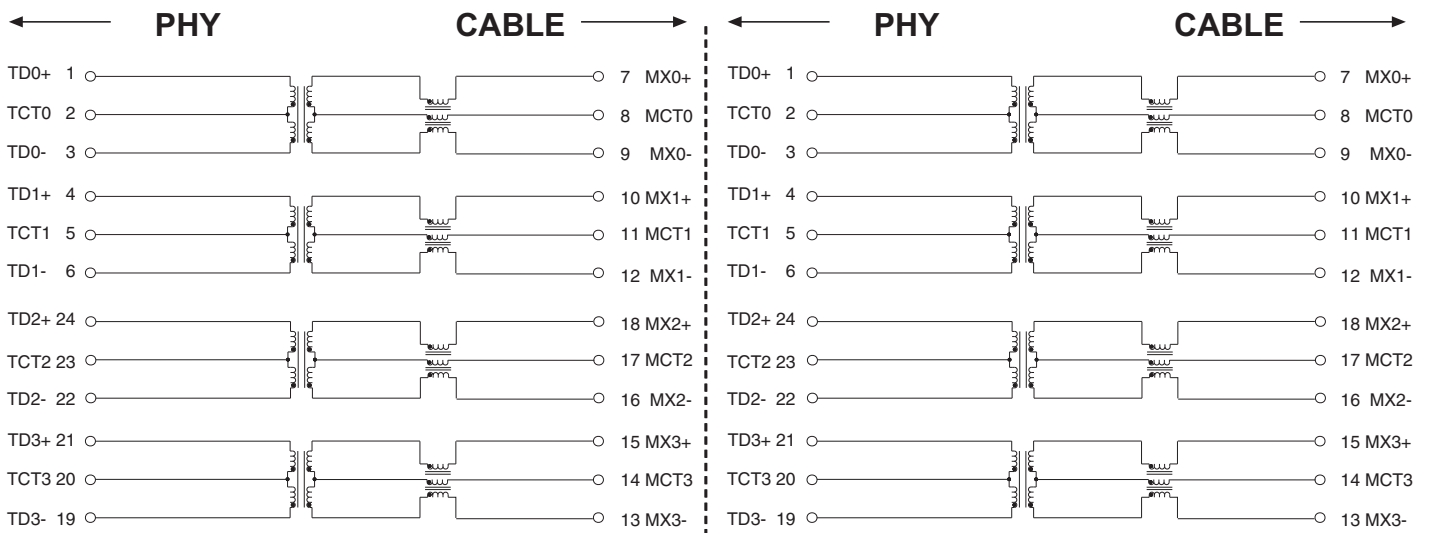

Schematics for dual ports

GIGABIT (10/100/1000 BASE-T QUAD- & DUAL-TRANSFORMER MODULES AND UNFILTERED CONNECTORS

Designed to Support PoE, Auto MDIX



Application Circuit

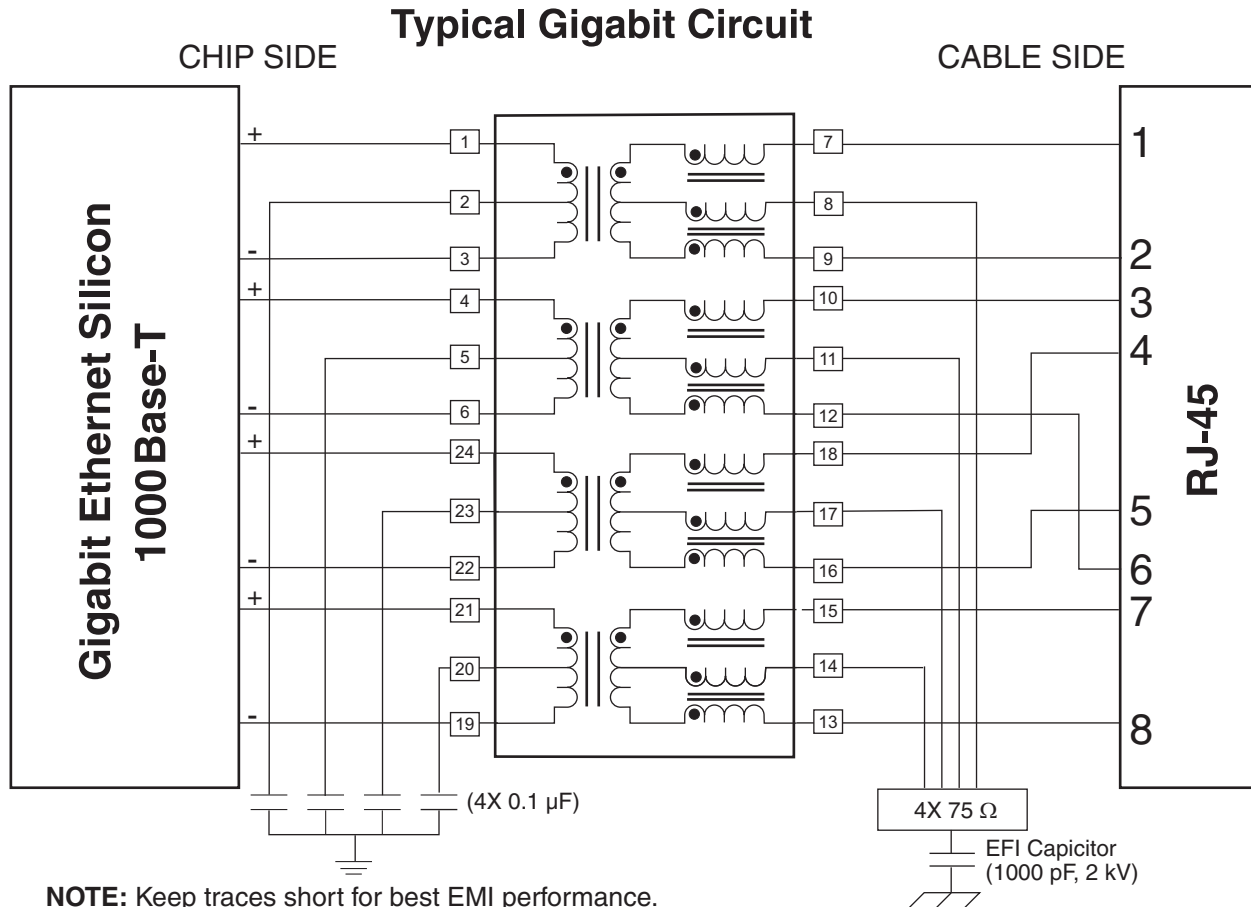

For More Information:

Pulse Worldwide Headquarters

12220 World Trade Dr.
San Diego, CA 92128
U.S.A.

www.pulseeng.com

Tel: 858 674 8100
Fax: 858 674 8262

Pulse Europe

Einsteinstrasse 1
D-71083 Herrenberg
Germany

Tel: 49 7032 7806 0

Fax: 49 7032 7806 135

Pulse China Headquarters

B402, Shenzhen Academy of
Aerospace Technology Bldg.
10th Kejinan Rd.
High-Tech Zone
Nanshan District
Shenzhen, R. O. China 518057

TEL: 86 755 33966678

FAX: 86 755 33966700

Pulse North China

Room 1503
XinYin Building
No. 888 YiShan Rd.
Shanghai 200233
China

Tel: 86 21 54643211/2

Fax: 86 21 54643210

Pulse South Asia

135 Joo Seng Rd.
#03-02
PM Industrial Bldg.
Singapore 368363

TEL: 65 6287 8998

FAX: 65 6280 0080

Pulse North Asia

No. 26, Kao Ching Rd.
Yang Mei Chen
Taoyuan Hsien
Taiwan
R. O. C.

Tel: 886 3 4643715

Fax: 886 3 4641911

Performance warranty of products offered on this data sheet is limited to the parameters specified. Data is subject to change without notice. Other brand and product names mentioned herein may be trademarks or registered trademarks of their respective owners.

© Copyright, 2010. Pulse Engineering, Inc. All rights reserved.

Looking for pricing, stock, or lifecycle information?

Click below to explore more details on WIN SOURCE:

 [View HX5401NL on WIN SOURCE](#)

 [Pulse Information](#)

Optimize Your Supply Chain with WIN SOURCE Solutions

-  Global Sourcing Solution
-  Obsolete Management
-  Cost Control Management
-  Shortage Management
-  Alternative Solution
-  Excess Inventory Management