

## LED Driver IC with Average-Mode Constant Current Control

### Features

- Fast Average Current Control
- Correction for Propagation Delay and Offset Voltage
- Fixed Offtime Switching Mode
- Linear Dimming Input
- PWM Dimming Input
- Output Short-Circuit Protection with Programmable Skip Mode
- Input Undervoltage Shutdown

### Applications

- Backlighting of LCD Panels
- General Lighting

### General Description

The HV9803 is an open-loop, Average-mode current control LED driver IC operating in a constant Offtime mode. The IC features  $\pm 2\%$  current accuracy and tight line and load regulation of the LED current without any need for loop compensation or high-side current sensing. Its auto-zero circuit cancels the effect of both the input offset voltage and the propagation delay in the current sense comparator.

The HV9803 can be powered from a 7V to 13.2V supply. The IC features fast PWM dimming response. The linear dimming input LD can accept a reference voltage of up to 2.5V.

The IC is equipped with a current limit comparator for Hiccup-mode output short-circuit protection. It also features a programmable input undervoltage shutdown.

### Package Type

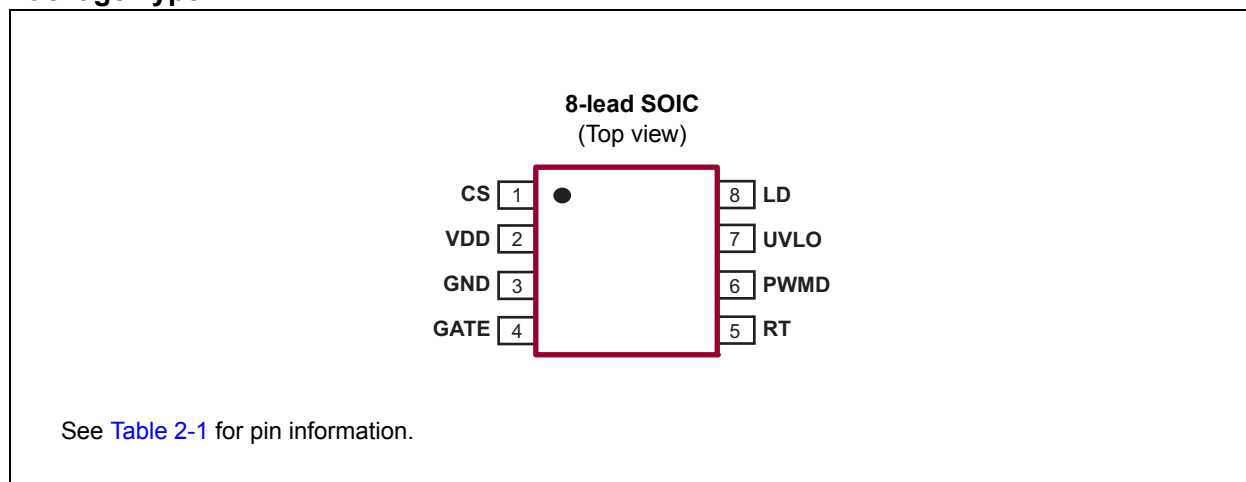

# HV9803

## Functional Block Diagram

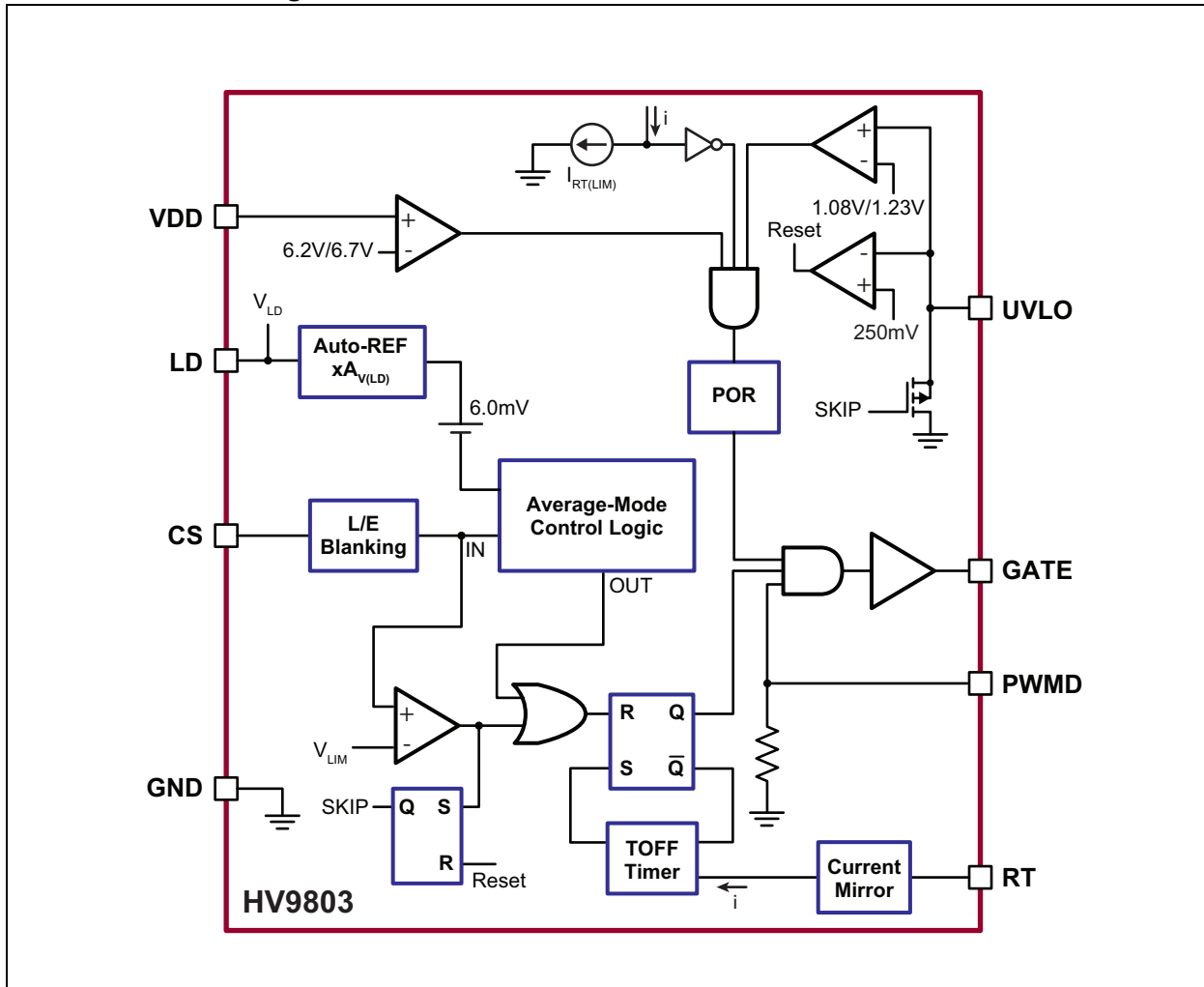

## Typical Application Circuit

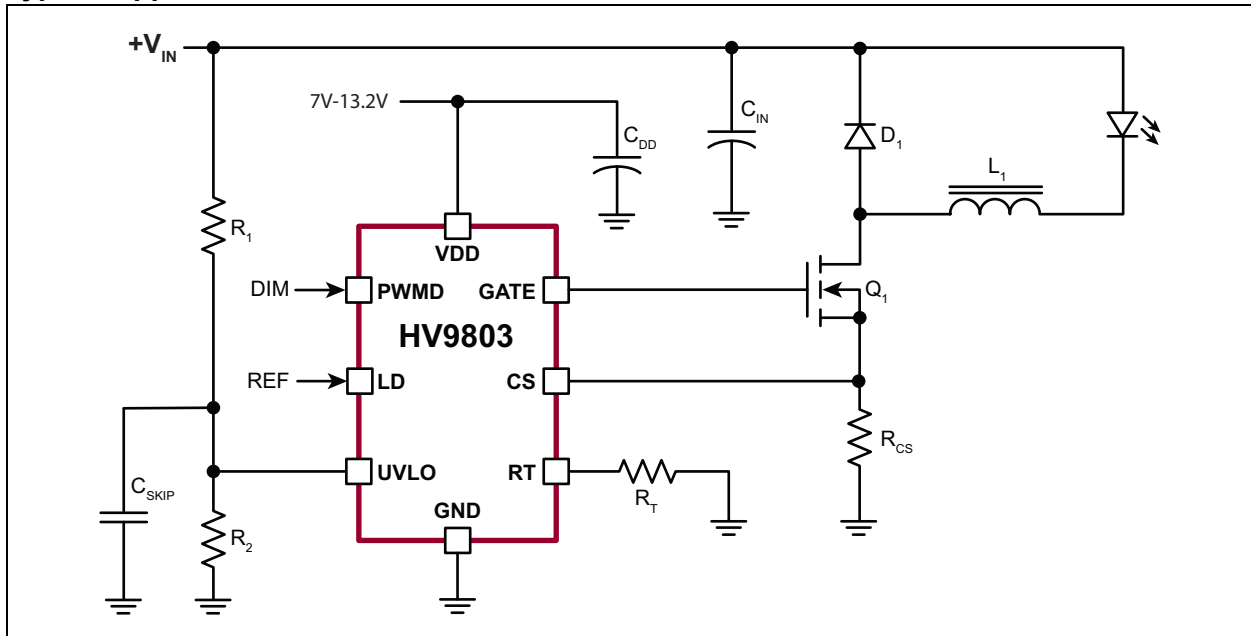

# HV9803

## 1.0 ELECTRICAL CHARACTERISTICS

### Absolute Maximum Ratings†

$V_{DD}$ , GATE, CS .....	-0.3V to +14V
LD, RT, PWMD, UVLO .....	-0.3V to +6V
Junction Temperature, $T_J$ .....	-40°C to +150°C
Storage Temperature, $T_S$ .....	-65°C to +150°C
Power Dissipation (at 25 °C):	
8-lead SOIC .....	650 mW

† **Notice:** Stresses above those listed under “Absolute Maximum Ratings” may cause permanent damage to the device. This is a stress rating only, and functional operation of the device at those or any other conditions above those indicated in the operational sections of this specification is not intended. Exposure to maximum rating conditions for extended periods may affect device reliability.

### DC ELECTRICAL CHARACTERISTICS

**Electrical Specifications:** Specifications apply over the full operating ambient temperature range,  $T_A = -40^\circ\text{C}$  to  $+125^\circ\text{C}$ . Unless otherwise noted,  $T_A = 25^\circ\text{C}$ ,  $V_{DD} = 12\text{V}$  and  $V_{PWMD} = 5\text{V}$ .

Parameter	Sym.	Min.	Typ.	Max	Unit	Conditions
<b>INPUT</b>						
Input DC Supply Voltage Range	$V_{DD}$	—	—	13.2	V	DC input voltage
Quiescent $V_{DD}$ Supply Current	$I_{DD}$	—	1.5	2.5	mA	$V_{CS} = 0\text{V}$
<b><math>V_{DD}</math> UNDERVOLTAGE LOCKOUT</b>						
$V_{DD}$ Undervoltage Lockout Upper Threshold	$V_{DDUV,R}$	6.45	6.7	6.95	V	$V_{DD}$ Rising
$V_{DD}$ Undervoltage Lockout Hysteresis	$\Delta V_{DDUV}$	—	500	—	mV	$V_{DD}$ Falling
<b>PWM DIMMING</b>						
PWMD Input Low Voltage	$V_{PWMD(LO)}$	—	—	1	V	
PWMD Input High Voltage	$V_{PWMD(HI)}$	2.6	—	—	V	
Internal Pull-Down Resistance at PWMD	$R_{PWMD}$	50	100	150	k $\Omega$	
<b>CURRENT SENSE COMPARATOR</b>						
External Reference Voltage	$V_{LD}$	0	—	3	V	
CS Threshold Voltage	$V_{CST}$	762	778	794	mV	$V_{LD} = 1.6\text{V}$
		955	975	995		$V_{LD} = 2\text{V}$
LD to CS Voltage Ratio	$A_{V(LD)}$	—	0.49	—	—	
Current Sense Blanking Interval	$T_{BLANK}$	150	—	280	ns	
Minimum On-Time	$T_{ON(MIN)}$	—	—	760	ns	$V_{CS} = 0.5 V_{LD} + 30\text{ mV}$
Maximum Steady State Duty Cycle	$D_{MAX}$	80	—	—	%	Reduction in output LED current may occur beyond this duty cycle.
<b>SHORT-CIRCUIT PROTECTION</b>						
Current Limit Threshold Voltage	$V_{LIM}$	1.57	1.75	1.93	V	
Current Limit Delay CS-to-GATE	$T_{DELAY}$	—	—	150	ns	$V_{CS} = V_{LIM} + 30\text{ mV}$
UVLO Skip Timer Reset Switch Resistance	$R_{UVRST}$	—	—	500	$\Omega$	

## DC ELECTRICAL CHARACTERISTICS (CONTINUED)

**Electrical Specifications:** Specifications apply over the full operating ambient temperature range,  $T_A = -40^{\circ}\text{C}$  to  $+125^{\circ}\text{C}$ . Unless otherwise noted,  $T_A = 25^{\circ}\text{C}$ ,  $V_{DD} = 12\text{V}$  and  $V_{PWMD} = 5\text{V}$ .

Parameter	Sym.	Min.	Typ.	Max	Unit	Conditions
UVLO Skip Timer Reset Voltage	$V_{UVRST}$	200	—	300	mV	
Minimum On-Time (Short Circuit)	$T_{ON(MIN)}$	—	—	430	ns	$V_{CS} = V_{LIM} + 30\text{ mV}$
<b>T<sub>OFF</sub> TIMER</b>						
Offtime	$T_{OFF}$	6.7	9	11.3	$\mu\text{s}$	$R_T = 250\text{ k}\Omega$
		0.8	1	1.2	$\mu\text{s}$	$R_T = 25\text{ k}\Omega$
RT Overcurrent Threshold	$I_{RT(LIM)}$	—	2.8	—	mA	
<b>GATE DRIVER</b>						
Gate Sourcing Current	$I_{SOURCE}$	0.165	—	—	A	$V_{GATE} = 0\text{V}$
Gate Sinking Current	$I_{SINK}$	0.165	—	—	A	$V_{GATE} = V_{DD}$
GATE Output Rise Time	$t_{RISE}$	—	30	50	ns	$C_{GATE} = 500\text{ pF}$
GATE Output Fall Time	$t_{FALL}$	—	30	50	ns	$C_{GATE} = 500\text{ pF}$
<b>UVLO</b>						
Undervoltage Upper Threshold Voltage	$V_{UVLO,R}$	1.17	1.23	1.29	V	$V_{UVLO}$ rising
Undervoltage Threshold Voltage Hysteresis	$\Delta V_{UVLO}$	—	150	—	mV	$V_{UVLO}$ falling

## TEMPERATURE SPECIFICATIONS

Parameter	Sym.	Min.	Typ.	Max.	Unit	Conditions
<b>TEMPERATURE RANGE</b>						
Operating Ambient Temperature	$T_A$	-40	—	+125	$^{\circ}\text{C}$	
Maximum Junction Temperature	$T_J$	—	—	+150	$^{\circ}\text{C}$	
Storage Temperature	$T_S$	-65	—	+150	$^{\circ}\text{C}$	
<b>PACKAGE THERMAL RESISTANCE</b>						
8-lead SOIC	$\theta_{JA}$	—	101	—	$^{\circ}\text{C/W}$	

# HV9803

---

## 2.0 PIN DESCRIPTION

The details on the pins of HV9803 are listed in [Table 2-1](#). See location of pins in [Package Type](#).

**TABLE 2-1: PIN FUNCTION TABLE**

Pin Number	Pin Name	Description
1	CS	This pin is the current sense pin used to detect the MOSFET source current by means of an external sense resistor.
2	VDD	This is the power supply input for the GATE output and input of the low-voltage regulator powering the internal logic. It must be bypassed with a low-ESR capacitor to GND (at least 0.1 $\mu$ F).
3	GND	Ground return for all internal circuitry. This pin must be electrically connected to the ground of the power train.
4	GATE	This pin is the output of gate driver for an external N-channel power MOSFET.
5	RT	A resistor connected between RT and GND programs the GATE offtime.
6	PWMD	This is the PWM dimming input of the IC. When this pin is pulled to GND, the gate driver is turned off. When the pin is pulled high, the gate driver operates normally.
7	UVLO	This pin is the undervoltage comparator input. It is also used to program a short-circuit protection skip delay.
8	LD	This pin is the reference voltage input for programming the LED current.

## 3.0 FUNCTIONAL DESCRIPTION

### 3.1 General

The peak-current control of a buck converter is the most economical and simplest way to regulate its output current. However, it suffers accuracy and regulation problems that arise from the peak-to-average current error due to the current ripple in the output inductor and the propagation delay in the current sense comparator. The full inductor current signal is unavailable for switch current sensing with current-sensing resistor in the ground path between the low-side switch and ground in a buck converter with low-side main switch configuration when the switch is turned-on. While it is very simple to detect the peak current in the switch, controlling the average inductor current is usually implemented by level-translating the current sense signal from the positive input supply rail. While this is practical for relatively low-input voltage, this type of average-current control may become excessively complex and expensive in the case of input voltages above 100V.

The HV9803 uses a control scheme that senses only the switch current to quickly and accurately control the average current in the buck inductor. No compensation of the current control loop is required. The inductor current ripple amplitude does not affect this control scheme significantly. The LED current is independent of the variation in inductance, switching frequency and output voltage. Constant offtime control of the buck converter is used for stability and to improve the LED current regulation over a wide range of input voltages. The IC features excellent PWM dimming response.

### 3.2 OFF Timer

In the HV9803, the timing resistor connected at the RT pin determines the offtime of the gate driver, and the resistor must be wired to GND. The equation governing the offtime of the GATE output is derived with [Equation 3-1](#).

#### EQUATION 3-1:

$$T_{OFF} = R_T \times 40pF$$

The RT input is protected from short circuit. Overcurrent condition at RT inhibits the IC.

### 3.3 Current Sense Comparator and Timer Circuits

The function of the HV9803's current sense comparator is similar to that of a peak current controller. However, the GATE pulse is not terminated immediately as the CS threshold is met. The GATE turn-off in the nth cycle is delayed by a time  $T_{2,n}$  determined by a timer circuit as shown in [Equation 3-2](#).

#### EQUATION 3-2:

$$T_{2,n} = \frac{1}{2} \times (T_{1,n} + T_{1,n-1})$$

Where  $T_{1,n}$  and  $T_{1,n-1}$  are the times to the CS threshold in any two consecutive switching cycles.

This iterative control law is needed for damping sub-harmonic oscillation. Note that the control law is only valid up to a maximum switching duty cycle,  $D_{MAX} = 0.8$ . Exceeding  $D_{MAX}$  will cause a reduction in the LED current.

Propagation delay in the current sense comparator is one of the most significant contributors to the LED current error. It must be noted that the control scheme described above does not improve this deficiency of the peak-current control scheme by itself. Moreover, it samples the propagation delay during  $T_1$  and replicates it during  $T_2$ , essentially doubling the error introduced by this delay. To eliminate this error, the reference voltage is corrected by an auto-zero circuit. In essence, the HV9803 samples its CS signal when the current sense comparator triggers and detects the difference between the sampled CS level and the reference input of the current sense comparator. The resulting difference is subtracted from the reference level to generate a new reference in the next switching cycle.

### 3.4 GATE Output

The GATE output of the HV9803 is used to drive an external MOSFET. It is recommended that the gate charge  $Q_G$  of the external MOSFET should be less than 25 nC for switching frequencies  $\leq 100$  kHz and less than 15 nC for switching frequencies  $> 100$  kHz.

The resulting LED current is calculated using [Equation 3-3](#).

#### EQUATION 3-3:

$$I_{LED} = \frac{0.49 \times V_{LD} - 6mV}{R_{CS}}$$

## 3.5 Short-Circuit Protection

The HV9803 is equipped with a short-circuit protection comparator having another CS threshold  $V_{LIM}$ . When this second threshold is triggered, the GATE output shuts off for the duration of a restart delay, determined by the RC constant set at UVLO pin. Meanwhile, the capacitor  $C_{SKIP}$  is discharged below 200 mV. The restart delay due to charging  $C_{SKIP}$  to the UVLO upper threshold is calculated as shown in [Equation 3-4](#).

### EQUATION 3-4:

$$T_{SKIP} = k \times R_1 \times C_{SKIP} \times I_n \times \left( \frac{k \times V_{IN} - 0.30V}{k \times V_{IN} - 1.17V} \right)$$

Where:

$$k = \frac{R_2}{R_1 + R_2}$$

## 3.6 Undervoltage Shutdown

Undervoltage comparator input is provided to disable the IC when the UVLO input is below the UVLO lower threshold. Hysteresis is provided to avoid oscillation.

## 3.7 Failure Modes and Effects Analysis (FMEA)

The HV9803 is designed to withstand short circuit between its adjacent pins without damage. [Table 3-1](#) describes the effect of such incidental short-circuit conditions.

**TABLE 3-1: SHORT-CIRCUIT MODES AND EFFECTS**

Short-Circuit Mode	Effect
CS to $V_{DD}$	The IC triggers the short-circuit protection and operates in the Auto-restart mode continuously.
$V_{DD}$ to GND	Short circuit across the 12V should cause the external bias supply overcurrent protection.
GND to GATE	This should cause the external bias supply overcurrent protection. The power MOSFET Q1 is off.
RT to PWM	<b>Case 1—PWM = Lo:</b> The RT pin sources its maximum current. GATE = 0V and Q1 is off. <b>Case 2—PWM = Hi:</b> The RT pin is pulled up, shutting off the timer. GATE is off.
PWM to UVLO	This overdrives the undervoltage threshold. However, since the $V_{IN}$ UV condition is harmless to the IC, there is no effect.
UVLO to LD	LD overdrives the UVLO. If LD is lower than the UVLO lower threshold, the IC shuts off. No effect otherwise.

## 4.0 PACKAGING INFORMATION

### 4.1 Package Marking Information

8-lead SOIC

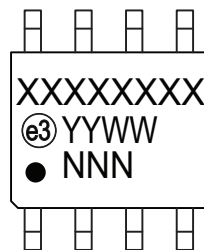

Example

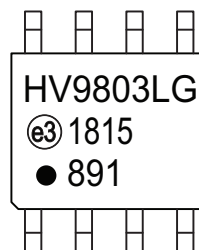

<b>Legend:</b>	XX...X	Product Code or Customer-specific information
	Y	Year code (last digit of calendar year)
	YY	Year code (last 2 digits of calendar year)
	WW	Week code (week of January 1 is week '01')
	NNN	Alphanumeric traceability code
	(e3)	Pb-free JEDEC® designator for Matte Tin (Sn)
	*	This package is Pb-free. The Pb-free JEDEC designator (e3) can be found on the outer packaging for this package.
<b>Note:</b>	In the event the full Microchip part number cannot be marked on one line, it will be carried over to the next line, thus limiting the number of available characters for product code or customer-specific information. Package may or not include the corporate logo.	

# HV9803

## 8-Lead SOIC (Narrow Body) Package Outline (LG/TG) 4.90x3.90mm body, 1.75mm height (max), 1.27mm pitch

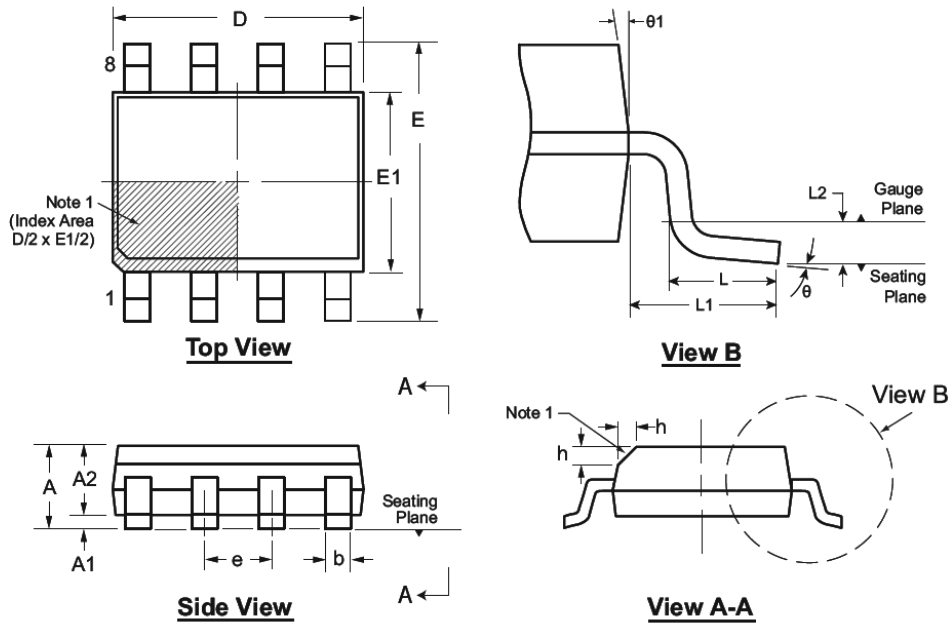

Note: For the most current package drawings, see the Microchip Packaging Specification at [www.microchip.com/packaging](http://www.microchip.com/packaging).

**Note:**

1. This chamfer feature is optional. A Pin 1 identifier must be located in the index area indicated. The Pin 1 identifier can be: a molded mark/identifier; an embedded metal marker; or a printed indicator.

Symbol	A	A1	A2	b	D	E	E1	e	h	L	L1	L2	$\theta$	$\theta 1$		
Dimension (mm)	MIN	1.35*	0.10	1.25	0.31	4.80*	5.80*	3.80*	1.27 BSC	0.25	0.40	1.04 REF	0.25	BSC	0°	5°
	NOM	-	-	-	-	4.90	6.00	3.90		-	-		-		-	
	MAX	1.75	0.25	1.65*	0.51	5.00*	6.20*	4.00*		0.50	1.27		8°		15°	

JEDEC Registration MS-012, Variation AA, Issue E, Sept. 2005.

\* This dimension is not specified in the JEDEC drawing.

Drawings are not to scale.

## APPENDIX A: REVISION HISTORY

### Revision A (August 2018)

- Converted Supertex Doc# DSFP-HV9803 to Microchip DS20005641A
- Changed the packaging quantity for the 8-lead SOIC LG package from 2500/Reel to 3300/Reel
- Added a maximum junction temperature to the Temperature Specifications Table
- Made minor text changes throughout the document

# HV9803

## PRODUCT IDENTIFICATION SYSTEM

To order or obtain information, e.g., on pricing or delivery, contact your local Microchip representative or sales office.

<u>PART NO.</u>	<u>XX</u>	-	<u>X</u>	-	<u>X</u>
Device	Package Options		Environmental		Media Type
Device:	HV9803	=	LED Driver IC with Average-Mode Constant Current Control		
Package:	LG	=	8-lead SOIC		
Environmental:	G	=	Lead (Pb)-free/RoHS-compliant Package		
Media Type:	(blank)	=	3300/Reel for an LG Package		

**Example:**

a) HV9803LG-G: LED Driver IC with Average-Mode Constant Current Control, 8-lead SOIC Package, 3300/Reel

---

---

**Note the following details of the code protection feature on Microchip devices:**

- Microchip products meet the specification contained in their particular Microchip Data Sheet.
- Microchip believes that its family of products is one of the most secure families of its kind on the market today, when used in the intended manner and under normal conditions.
- There are dishonest and possibly illegal methods used to breach the code protection feature. All of these methods, to our knowledge, require using the Microchip products in a manner outside the operating specifications contained in Microchip's Data Sheets. Most likely, the person doing so is engaged in theft of intellectual property.
- Microchip is willing to work with the customer who is concerned about the integrity of their code.
- Neither Microchip nor any other semiconductor manufacturer can guarantee the security of their code. Code protection does not mean that we are guaranteeing the product as “unbreakable.”

Code protection is constantly evolving. We at Microchip are committed to continuously improving the code protection features of our products. Attempts to break Microchip's code protection feature may be a violation of the Digital Millennium Copyright Act. If such acts allow unauthorized access to your software or other copyrighted work, you may have a right to sue for relief under that Act.

---

Information contained in this publication regarding device applications and the like is provided only for your convenience and may be superseded by updates. It is your responsibility to ensure that your application meets with your specifications. MICROCHIP MAKES NO REPRESENTATIONS OR WARRANTIES OF ANY KIND WHETHER EXPRESS OR IMPLIED, WRITTEN OR ORAL, STATUTORY OR OTHERWISE, RELATED TO THE INFORMATION, INCLUDING BUT NOT LIMITED TO ITS CONDITION, QUALITY, PERFORMANCE, MERCHANTABILITY OR FITNESS FOR PURPOSE. Microchip disclaims all liability arising from this information and its use. Use of Microchip devices in life support and/or safety applications is entirely at the buyer's risk, and the buyer agrees to defend, indemnify and hold harmless Microchip from any and all damages, claims, suits, or expenses resulting from such use. No licenses are conveyed, implicitly or otherwise, under any Microchip intellectual property rights unless otherwise stated.

*Microchip received ISO/TS-16949:2009 certification for its worldwide headquarters, design and wafer fabrication facilities in Chandler and Tempe, Arizona; Gresham, Oregon and design centers in California and India. The Company's quality system processes and procedures are for its PIC® MCUs and dsPIC® DSCs, KEELOQ® code hopping devices, Serial EEPROMs, microperipherals, nonvolatile memory and analog products. In addition, Microchip's quality system for the design and manufacture of development systems is ISO 9001:2000 certified.*

**QUALITY MANAGEMENT SYSTEM  
CERTIFIED BY DNV  
= ISO/TS 16949 =**

### **Trademarks**

The Microchip name and logo, the Microchip logo, AnyRate, AVR, AVR logo, AVR Freaks, BitCloud, chipKIT, chipKIT logo, CryptoMemory, CryptoRF, dsPIC, FlashFlex, flexPWR, Heldo, JukeBlox, KeeLoq, Klear, LANCheck, LINK MD, maXStylus, maXTouch, MediaLB, megaAVR, MOST, MOST logo, MPLAB, OptoLyzer, PIC, picoPower, PICSTART, PIC32 logo, Prochip Designer, QTouch, SAM-BA, SpyNIC, SST, SST Logo, SuperFlash, tinyAVR, UNI/O, and XMEGA are registered trademarks of Microchip Technology Incorporated in the U.S.A. and other countries.

ClockWorks, The Embedded Control Solutions Company, EtherSynch, Hyper Speed Control, HyperLight Load, IntellIMOS, mTouch, Precision Edge, and Quiet-Wire are registered trademarks of Microchip Technology Incorporated in the U.S.A.

Adjacent Key Suppression, AKS, Analog-for-the-Digital Age, Any Capacitor, AnyIn, AnyOut, BodyCom, CodeGuard, CryptoAuthentication, CryptoAutomotive, CryptoCompanion, CryptoController, dsPICDEM, dsPICDEM.net, Dynamic Average Matching, DAM, ECAN, EtherGREEN, In-Circuit Serial Programming, ICSP, INICnet, Inter-Chip Connectivity, JitterBlocker, KlearNet, KlearNet logo, memBrain, Mindi, MiWi, motorBench, MPASM, MPF, MPLAB Certified logo, MPLIB, MPLINK, MultiTRAK, NetDetach, Omniscient Code Generation, PICDEM, PICDEM.net, PICKit, PICtail, PowerSmart, PureSilicon, QMatrix, REAL ICE, Ripple Blocker, SAM-ICE, Serial Quad I/O, SMART-I.S., SQI, SuperSwitcher, SuperSwitcher II, Total Endurance, TSHARC, USBCheck, VariSense, ViewSpan, WiperLock, Wireless DNA, and ZENA are trademarks of Microchip Technology Incorporated in the U.S.A. and other countries.

SQTP is a service mark of Microchip Technology Incorporated in the U.S.A.

Silicon Storage Technology is a registered trademark of Microchip Technology Inc. in other countries.

GestIC is a registered trademark of Microchip Technology Germany II GmbH & Co. KG, a subsidiary of Microchip Technology Inc., in other countries.

All other trademarks mentioned herein are property of their respective companies.

© 2018, Microchip Technology Incorporated, All Rights Reserved.  
ISBN: 978-1-5224-3476-4



# MICROCHIP

## Worldwide Sales and Service

### AMERICAS

**Corporate Office**  
2355 West Chandler Blvd.  
Chandler, AZ 85224-6199  
Tel: 480-792-7200  
Fax: 480-792-7277  
Technical Support:  
<http://www.microchip.com/support>  
Web Address:  
[www.microchip.com](http://www.microchip.com)

#### Atlanta

Duluth, GA  
Tel: 678-957-9614  
Fax: 678-957-1455

#### Austin, TX

Tel: 512-257-3370

#### Boston

Westborough, MA  
Tel: 774-760-0087  
Fax: 774-760-0088

#### Chicago

Itasca, IL  
Tel: 630-285-0071  
Fax: 630-285-0075

#### Dallas

Addison, TX  
Tel: 972-818-7423  
Fax: 972-818-2924

#### Detroit

Novi, MI  
Tel: 248-848-4000

#### Houston, TX

Tel: 281-894-5983

#### Indianapolis

Noblesville, IN  
Tel: 317-773-8323  
Fax: 317-773-5453  
Tel: 317-536-2380

#### Los Angeles

Mission Viejo, CA  
Tel: 949-462-9523  
Fax: 949-462-9608  
Tel: 951-273-7800

#### Raleigh, NC

Tel: 919-844-7510

#### New York, NY

Tel: 631-435-6000

#### San Jose, CA

Tel: 408-735-9110  
Tel: 408-436-4270

#### Canada - Toronto

Tel: 905-695-1980  
Fax: 905-695-2078

### ASIA/PACIFIC

**Australia - Sydney**  
Tel: 61-2-9868-6733

**China - Beijing**  
Tel: 86-10-8569-7000

**China - Chengdu**  
Tel: 86-28-8665-5511

**China - Chongqing**  
Tel: 86-23-8980-9588

**China - Dongguan**  
Tel: 86-769-8702-9880

**China - Guangzhou**  
Tel: 86-20-8755-8029

**China - Hangzhou**  
Tel: 86-571-8792-8115

**China - Hong Kong SAR**  
Tel: 852-2943-5100

**China - Nanjing**  
Tel: 86-25-8473-2460

**China - Qingdao**  
Tel: 86-532-8502-7355

**China - Shanghai**  
Tel: 86-21-3326-8000

**China - Shenyang**  
Tel: 86-24-2334-2829

**China - Shenzhen**  
Tel: 86-755-8864-2200

**China - Suzhou**  
Tel: 86-186-6233-1526

**China - Wuhan**  
Tel: 86-27-5980-5300

**China - Xian**  
Tel: 86-29-8833-7252

**China - Xiamen**  
Tel: 86-592-2388138

**China - Zhuhai**  
Tel: 86-756-3210040

### ASIA/PACIFIC

**India - Bangalore**  
Tel: 91-80-3090-4444

**India - New Delhi**  
Tel: 91-11-4160-8631

**India - Pune**  
Tel: 91-20-4121-0141

**Japan - Osaka**  
Tel: 81-6-6152-7160

**Japan - Tokyo**  
Tel: 81-3-6880-3770

**Korea - Daegu**  
Tel: 82-53-744-4301

**Korea - Seoul**  
Tel: 82-2-554-7200

**Malaysia - Kuala Lumpur**  
Tel: 60-3-7651-7906

**Malaysia - Penang**  
Tel: 60-4-227-8870

**Philippines - Manila**  
Tel: 63-2-634-9065

**Singapore**  
Tel: 65-6334-8870

**Taiwan - Hsin Chu**  
Tel: 886-3-577-8366

**Taiwan - Kaohsiung**  
Tel: 886-7-213-7830

**Taiwan - Taipei**  
Tel: 886-2-2508-8600

**Thailand - Bangkok**  
Tel: 66-2-694-1351

**Vietnam - Ho Chi Minh**  
Tel: 84-28-5448-2100

### EUROPE

**Austria - Wels**  
Tel: 43-7242-2244-39  
Fax: 43-7242-2244-393

**Denmark - Copenhagen**  
Tel: 45-4450-2828  
Fax: 45-4485-2829

**Finland - Espoo**  
Tel: 358-9-4520-820

**France - Paris**  
Tel: 33-1-69-53-63-20  
Fax: 33-1-69-30-90-79

**Germany - Garching**  
Tel: 49-8931-9700

**Germany - Haan**  
Tel: 49-2129-3766400

**Germany - Heilbronn**  
Tel: 49-7131-67-3636

**Germany - Karlsruhe**  
Tel: 49-721-625370

**Germany - Munich**  
Tel: 49-89-627-144-0  
Fax: 49-89-627-144-44

**Germany - Rosenheim**  
Tel: 49-8031-354-560

**Israel - Ra'anana**  
Tel: 972-9-744-7705

**Italy - Milan**  
Tel: 39-0331-742611  
Fax: 39-0331-466781

**Italy - Padova**  
Tel: 39-049-7625286

**Netherlands - Drunen**  
Tel: 31-416-690399  
Fax: 31-416-690340

**Norway - Trondheim**  
Tel: 47-7288-4388

**Poland - Warsaw**  
Tel: 48-22-3325737

**Romania - Bucharest**  
Tel: 40-21-407-87-50

**Spain - Madrid**  
Tel: 34-91-708-08-90  
Fax: 34-91-708-08-91

**Sweden - Gothenberg**  
Tel: 46-31-704-60-40

**Sweden - Stockholm**  
Tel: 46-8-5090-4654

**UK - Wokingham**  
Tel: 44-118-921-5800  
Fax: 44-118-921-5820

## Looking for pricing, stock, or lifecycle information?

Click below to explore more details on WIN SOURCE:

-  [View HV9803LG-G on WIN SOURCE](#)
-  [Microchip Technology](#) Information

## Optimize Your Supply Chain with WIN SOURCE Solutions

-  Global Sourcing Solution
-  Obsolete Management
-  Cost Control Management
-  Shortage Management
-  Alternative Solution
-  Excess Inventory Management