



**THE DATASHEET OF  
HV833MG**



## High Voltage EL Lamp Driver

### Features

- ▶ 1.8 to 6.5V operating supply voltage
- ▶ DC to AC conversion
- ▶ Separately adjustable lamp and converter frequency
- ▶ Output voltage regulation
- ▶ Enable/disable function
- ▶ Patented output timing for high efficiency
- ▶ <100nA shutdown current
- ▶ Split supply capability
- ▶ LCD backlighting

### Applications

- ▶ Portable transceivers
- ▶ Remote control units
- ▶ Calculators
- ▶ PDAs
- ▶ Global Positioning Systems (GPS)

### General Description

The Supertex HV833 is a high voltage driver designed for driving EL lamps of up to 35nF (10-12in<sup>2</sup>). The input supply voltage range is from 1.8 to 6.5V. The device uses a single inductor and a minimum number of passive components. The nominal regulated output voltage that is applied to the EL lamp is  $\pm 90V$ . The chip can be enabled/disabled by connecting a resistor between the RSW-Osc pin and the VDD/GND pins.

The HV833 has two internal oscillators, a switching MOSFET, and a high voltage EL lamp driver. The frequency for the switching MOSFET is set by an external resistor connected between the RSW-Osc pin and the VDD supply pin. The EL lamp driver frequency is set by an external resistor connected between the REL-Osc pin and the VDD pin. An external inductor is connected between the LX pin and VDD or VIN pin. A 0.003-0.1 $\mu$ F capacitor is connected between the CS pin and the GND pin. The EL lamp is connected between the VA pin and the VB pin.

The switching MOSFET charges the external inductor and discharges it into the capacitor at CS. The voltage at CS will start to increase. Once the voltage at CS reaches a nominal value of 90V, the switching MOSFET is turned OFF to conserve power. The outputs VA and VB are configured as an H bridge and are switching in opposite states to achieve 180V peak-to-peak across the EL lamp.

### Typical Application Circuit

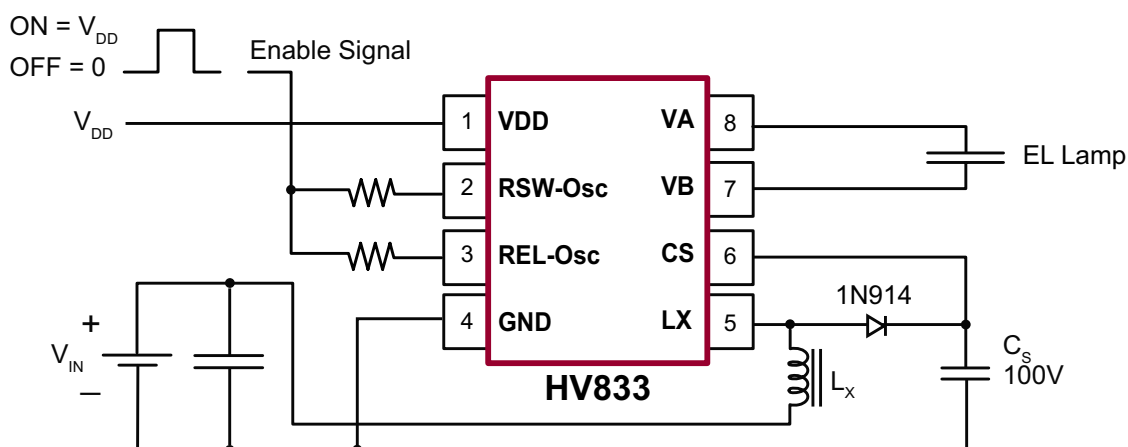

## Ordering Information

Part Number	Package	Packing
HV833MG-G	8-Lead MSOP	2500/Reel

-G denotes a lead (Pb)-free / RoHS compliant package

## Absolute Maximum Ratings

Parameter	Value
Supply voltage $V_{DD}$	-0.5V to 7.5V
Output voltage, $V_{CS}$	-0.5V to 125V
Operating temperature	-40°C to +85°C
Storage temperature	-65°C to +150°C
Power dissipation	300mW

Absolute Maximum Ratings are those values beyond which damage to the device may occur. Functional operation under these conditions is not implied. Continuous operation of the device at the absolute rating level may affect device reliability. All voltages are referenced to device ground.

## Typical Thermal Resistance

Package	$\theta_{ja}$
8-Lead MSOP	216°C/W

## Pin Configuration

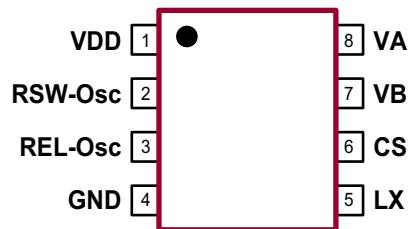

8-Lead MSOP  
(top view)

## Product Marking

Top Marking

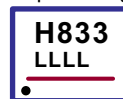

L = Lot Number

YY = Year Sealed

Bottom Marking



WW = Week Sealed

— = "Green" Packaging

Package may or may not include the following marks: Si or

8-Lead MSOP

## Recommended Operating Conditions

Sym	Parameter	Min	Typ	Max	Units	Conditions
$V_{DD}$	Supply voltage	1.8	-	6.5	V	---
$f_{EL}$	$V_{A-B}$ output drive frequency	60	-	1000	Hz	---
$T_A$	Operating temperature	-25	-	+85	°C	---

## DC Electrical Characteristics (Over recommended operating conditions unless otherwise specified, $T_A = 25^\circ\text{C}$ )

Sym	Parameter	Min	Typ	Max	Units	Conditions
$R_{DS(ON)}$	On-resistance of switching transistor	-	-	4.0	$\Omega$	$I = 100\text{mA}$
$V_{CS}$	Max. output regulation voltage	80	90	100	V	$V_{DD} = 1.8$ to $6.5\text{V}$
$V_{A-B}$	Max differential output voltage across lamp	160	180	200	V	$V_{DD} = 1.8$ to $6.5\text{V}$
$I_{DDQ}$	Quiescent $V_{DD}$ supply current	-	-	100	nA	$R_{SW-Osc} = \text{Low}$
$I_{DD}$	Input current going into the VDD pin	-	-	150	$\mu\text{A}$	$V_{DD} = 1.8$ to $6.5\text{V}$ . See Fig. 1
$I_{IN}$	Input current including inductor current	-	56	64	mA	$V_{IN} = 3.3\text{V}$ . See Fig. 1.
$V_{CS}$	Output voltage on $V_{CS}$	63	72	81	V	$V_{IN} = 3.3\text{V}$ . See Fig. 1.
$f_{EL}$	$V_{DIFF}$ output drive frequency	240	270	300	Hz	$V_{IN} = 3.3\text{V}$ . See Fig. 1.
$F_{SW}$	Switching transistor frequency	55	65	75	kHz	$V_{IN} = 3.3\text{V}$ . See Fig. 1.
D	Switching transistor duty cycle	-	88	-	%	See Fig. 1.

Enable/Disable Function Table

Sym	Parameter	Min	Typ	Max	Units	Conditions
EN-L	Logic input low voltage	0	-	0.5	V	$V_{DD} = 1.8$ to $6.5V$
EN-H	Logic input high voltage	$V_{DD} - 0.5$	-	$V_{DD}$	V	$V_{DD} = 1.8$ to $6.5V$

Functional Block Diagram

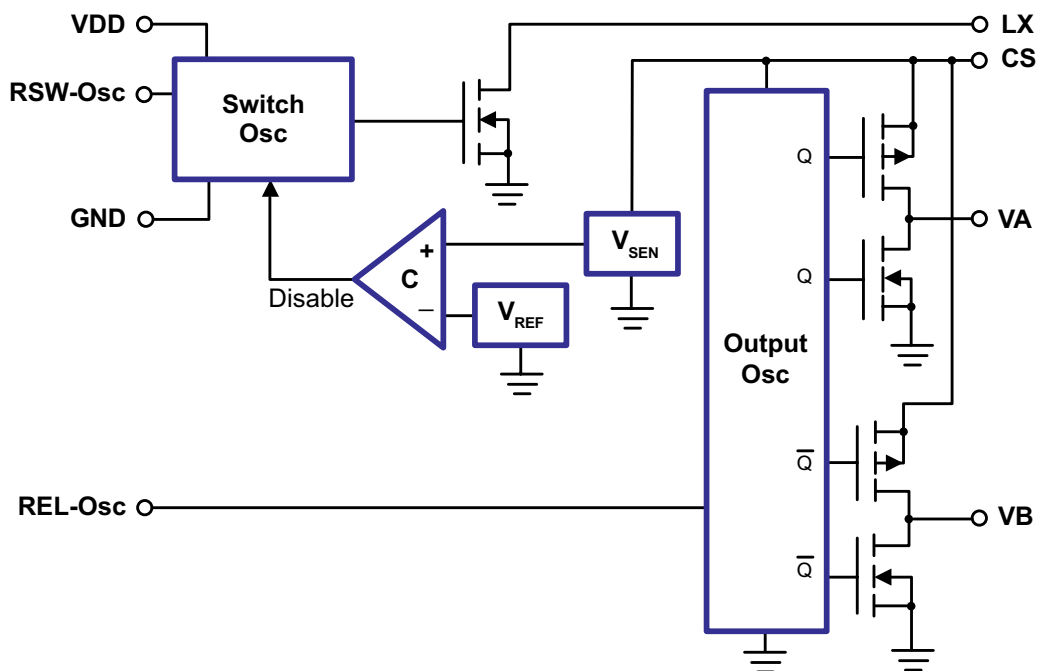

## Fig. 1: Typical Application/Test Circuit

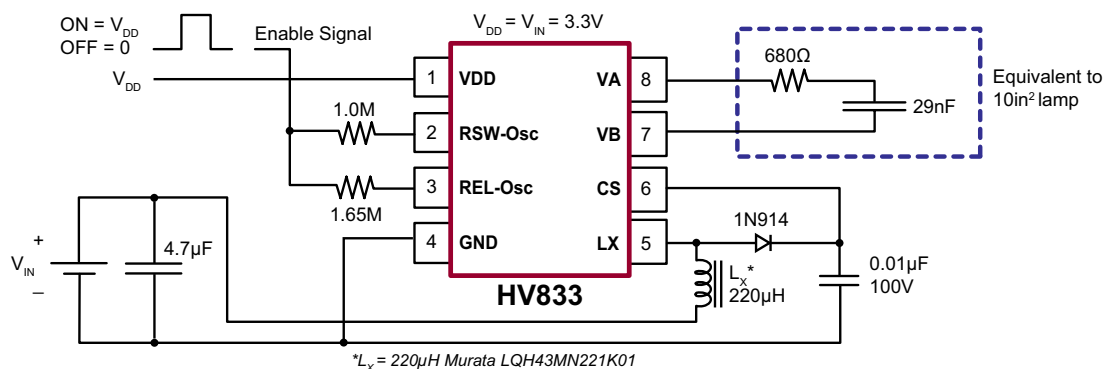

## Typical Performance

Device	Lamp Size	$V_{IN}$	$I_{IN}$	$V_{CS}$	$f_{EL}$	Brightness	$T_A$
HV833MG	10in <sup>2</sup>	3.3V	56mA	72V	270Hz	5.0ft-Im	-25°C to + 85°C

## Typical Performance Curves for Fig. 1 (EL Lamp = 10.0in<sup>2</sup>, $V_{IN} = V_{DD}$ )

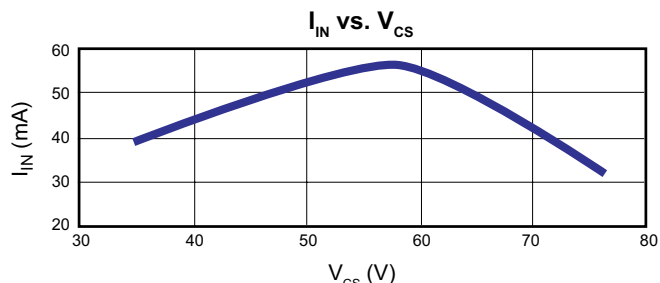
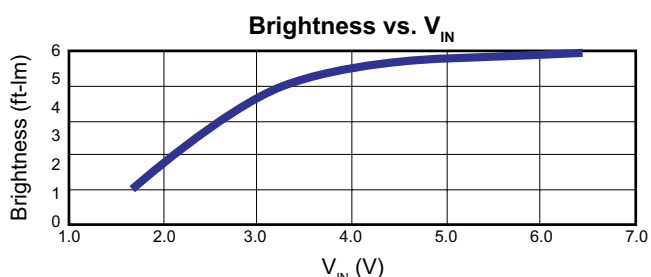
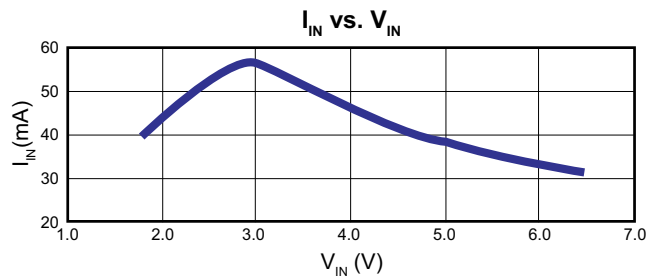
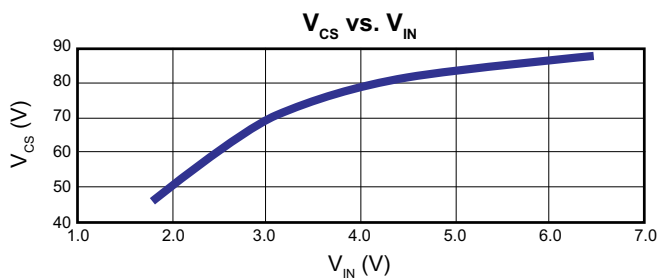
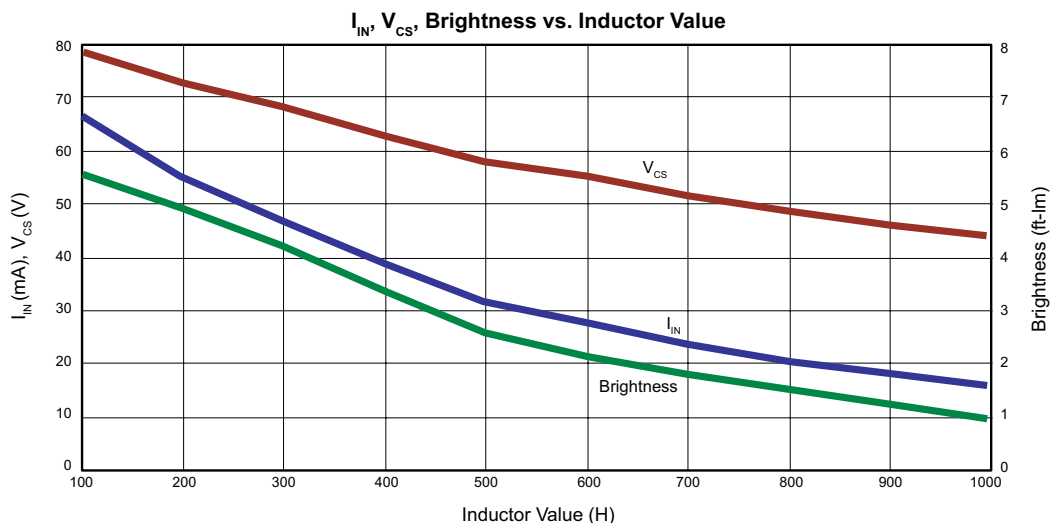

## Fig. 2: Typical Application

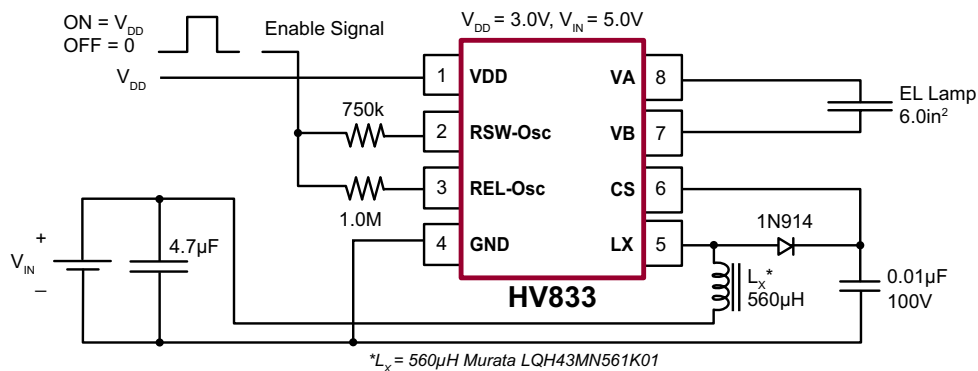

## Typical Performance

Device	Lamp Size	V <sub>IN</sub>	I <sub>IN</sub>	V <sub>CS</sub>	f <sub>EL</sub>	Brightness	T <sub>A</sub>
HV833MG	6.0in <sup>2</sup>	5.0V	30mA	70V	440Hz	6.0ft-lm	-25°C to + 85°C

## Typical Performance Curves for Fig. 2 (EL Lamp = 6.0in<sup>2</sup>, V<sub>DD</sub> = 3.0, V<sub>IN</sub> = 5.0V)

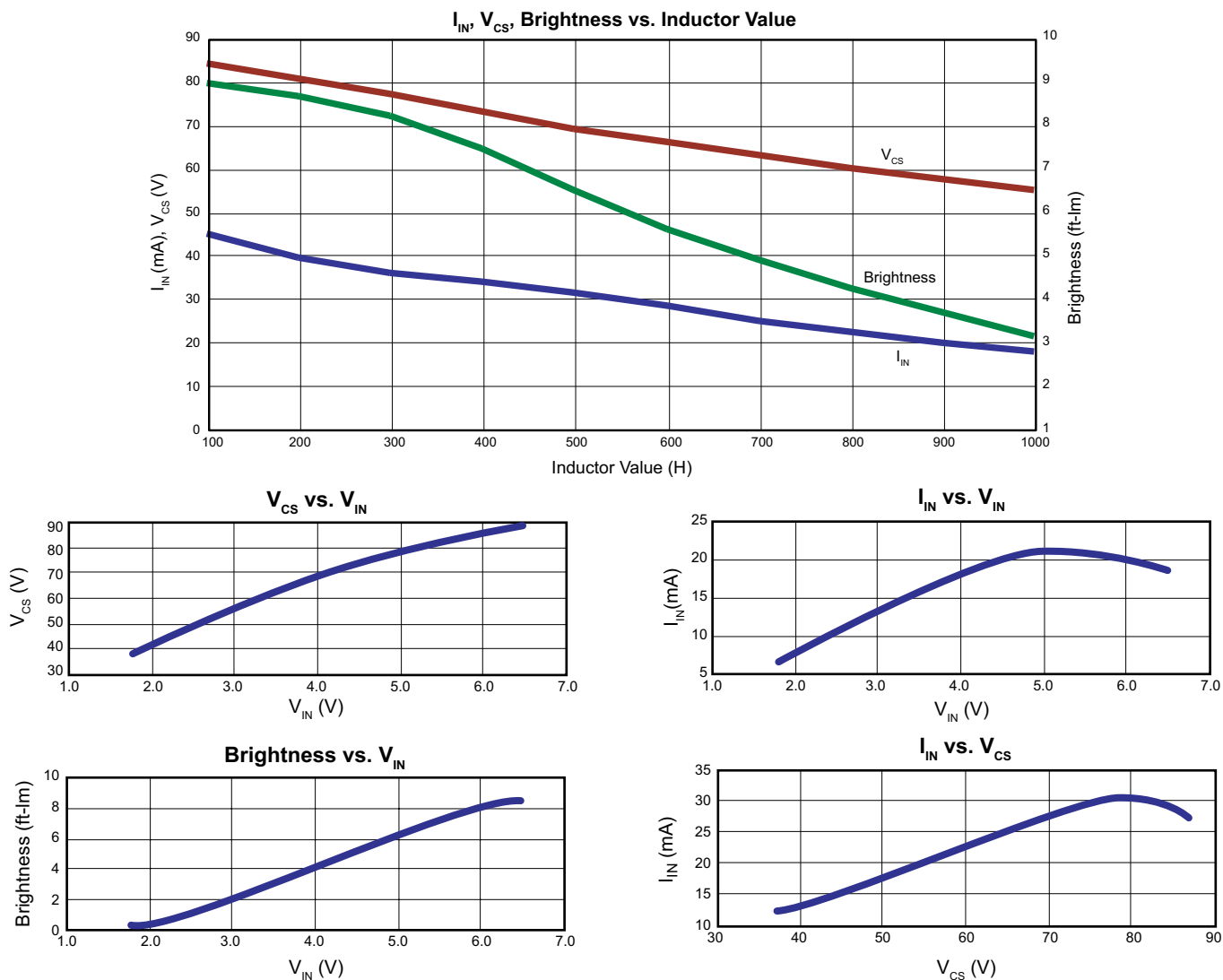

## Fig. 3: Typical Application

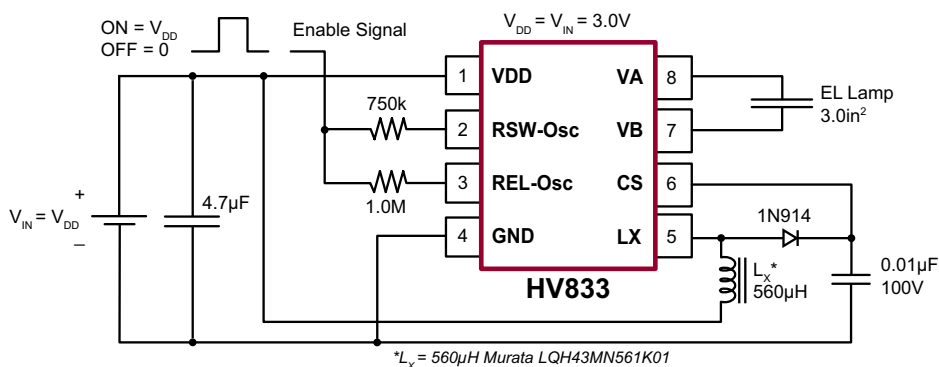

## Typical Performance

Device	Lamp Size	$V_{IN}$	$I_{IN}$	$V_{CS}$	$f_{EL}$	Brightness	$T_A$
HV833MG	3.0in <sup>2</sup>	3.0V	20mA	60V	440Hz	4.0ft-Im	-25°C to + 85°C

## Typical Performance Curves for Fig. 3 (EL Lamp = 3.0in<sup>2</sup>, $V_{IN} = V_{DD}$ )

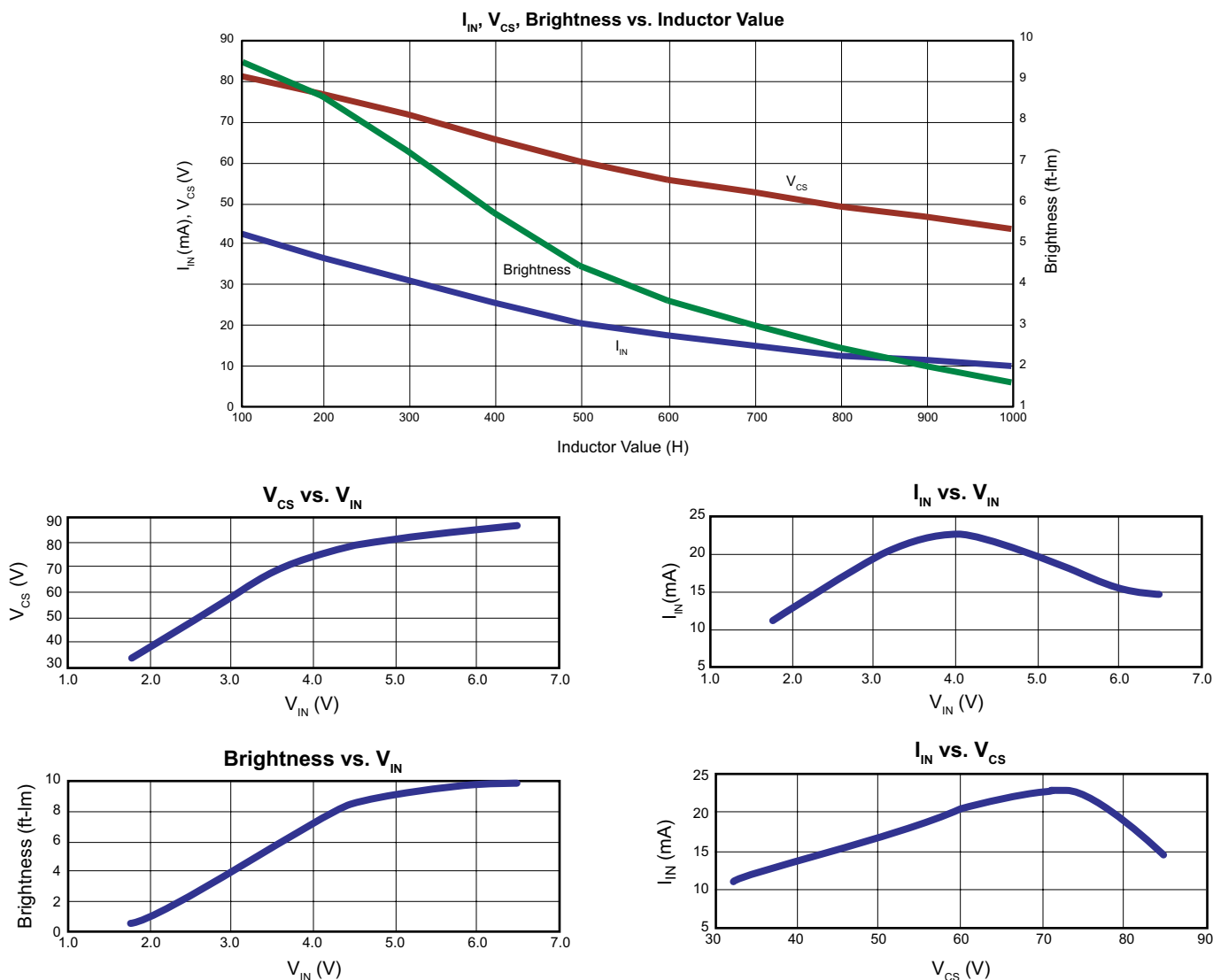

## Enable/Disable Configuration

The HV833 can be easily enabled and disabled via a logic control signal on the  $R_{SW}$  and  $R_{EL}$  resistors as shown in the Typical Application Circuit on the front page. The control signal can be from a microprocessor.  $R_{SW}$  and  $R_{EL}$  are typically

very high values. Therefore, only 10's of microamperes will be drawn from the logic signal when it is at a logic high (enable) state. When the microprocessor signal is high the device is enabled and when the signal is low, it is disabled.

## Enable/Disable Table

Enable Signal	HV833
$V_{DD}$	Enable
0V	Disable

## Split Supply Configuration for Battery Voltages of Higher than 6.5V

The Typical Application Circuit on the first page can also be used with high battery voltages such as 12V as long as the input voltage,  $V_{DD}$ , to the HV833 device is within its speci-

fications of 1.8V to 6.5V. Split supply configuration is shown on Fig. 2.

## External Component Description

External Component	Selection Guide Line
Diode	Fast reverse recovery diode, 100V 1N4148 or equivalent.
$C_S$ Capacitor	0.003 $\mu$ F to 0.1 $\mu$ F, 100V capacitor to GND is used to store the energy transferred from the inductor.
$R_{EL-Osc}$	The EL lamp frequency is controlled via an external $R_{EL}$ resistor connected between REL-Osc and VDD pins of the device. The lamp frequency increases as $R_{EL}$ decreases. As the EL lamp frequency increases, the amount of current drawn from the battery will increase and the output voltage $V_{CS}$ will decrease. The color of the EL lamp is dependent upon its frequency.
$R_{SW-Osc}$	The switching frequency of the converter is controlled via an external resistor, $R_{SW}$ between the RSW-Osc and VDD pins of the device. The switching frequency increases as $R_{SW}$ decreases. With a given inductor, as the switching frequency increases, the amount of current drawn from the battery will decrease and the output voltage, $V_{CS}$ , will also decrease.
$L_x$ Inductor	The inductor $L_x$ is used to boost the low input voltage by inductive flyback. When the internal switch is on, the inductor is being charged. When the internal switch is off, the charge stored in the inductor will be transferred to the high voltage capacitor $C_S$ . The energy stored in the capacitor is connected to the internal H-bridge, and therefore to the EL lamp. In general, smaller value inductors, which can handle more current, are more suitable to drive larger size lamps. As the inductor value decreases, the switching frequency of the inductor (controlled by $R_{SW}$ ) should be increased to avoid saturation.  A 220 $\mu$ H Murata (LQH43MN221) inductor with 5.4 $\Omega$ series DC resistance is typically recommended. For inductors with the same inductance value but with lower series DC resistance, a lower $R_{SW}$ value is needed to prevent high current draw and inductor saturation.
Lamp	As the EL lamp size increases, more current will be drawn from the battery to maintain high voltage across the EL lamp. The input power, ( $V_{IN} \times I_{IN}$ ), will also increase. If the input power is greater than the power dissipation of the package (300mW), an external resistor in series with one side of the lamp is recommended to help reduce the package power dissipation.

# 8-Lead MSOP Package Outline (MG)

3.00x3.00mm body, 1.10mm height (max), 0.65mm pitch

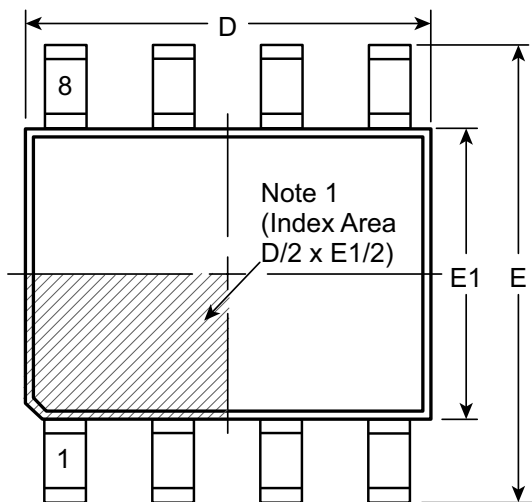

**Top View**

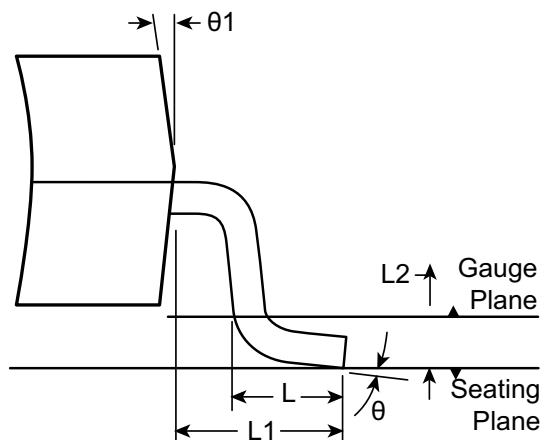

**View B**

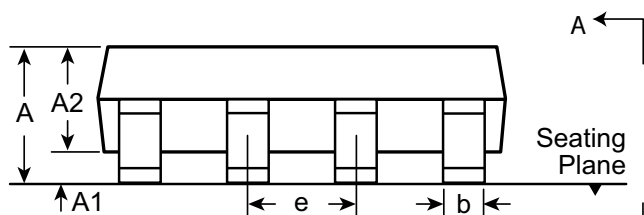

**Side View**

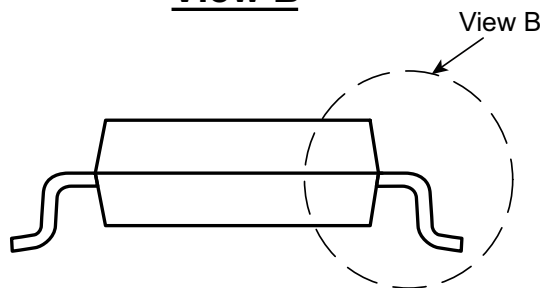

**View A-A**

**Note:**  
 1. A Pin 1 identifier must be located in the index area indicated. The Pin 1 identifier can be: a molded mark/identifier; an embedded metal marker; or a printed indicator.

Symbol	A	A1	A2	b	D	E	E1	e	L	L1	L2	θ	θ1	
Dimension (mm)	MIN	0.75*	0.00	0.75	0.22	2.80*	4.65*	2.80*	0.65 BSC	0.40	0.95 REF	0.25 BSC	0°	5°
	NOM	-	-	0.85	-	3.00	4.90	3.00		0.60			-	-
	MAX	1.10	0.15	0.95	0.38	3.20*	5.15*	3.20*		0.80			8°	15°

JEDEC Registration MO-187, Variation AA, Issue E, Dec. 2004.

\* This dimension is not specified in the JEDEC drawing.

Drawings are not to scale.

Supertex Doc. #: DSPD-8MSOPMG, Version H041309.

(The package drawing(s) in this data sheet may not reflect the most current specifications. For the latest package outline information go to <http://www.supertex.com/packaging.html>.)

Supertex inc. does not recommend the use of its products in life support applications, and will not knowingly sell them for use in such applications unless it receives an adequate "product liability indemnification insurance agreement." Supertex inc. does not assume responsibility for use of devices described, and limits its liability to the replacement of the devices determined defective due to workmanship. No responsibility is assumed for possible omissions and inaccuracies. Circuitry and specifications are subject to change without notice. For the latest product specifications refer to the Supertex inc. (website: <http://www.supertex.com>)

## Looking for pricing, stock, or lifecycle information?

Click below to explore more details on WIN SOURCE:

- ⊖ [View HV833MG on WIN SOURCE](#)
- ⊖ [Microchip Technology](#) Information

## Optimize Your Supply Chain with WIN SOURCE Solutions

- ✓ Global Sourcing Solution
- ✓ Obsolete Management
- ✓ Cost Control Management
- ✓ Shortage Management
- ✓ Alternative Solution
- ✓ Excess Inventory Management