

High-Voltage EL Lamp Driver IC

Features

- Processed with HVCMOS® Technology
- 1.0 to 1.6V Operating Supply Voltage
- DC to AC Conversion
- Output Load of Typically up to 6.0 nF
- Adjustable Output Lamp Frequency
- Adjustable Converter Frequency
- Enable Function

Applications

- Pagers
- Portable Transceivers
- Cellular Phones
- Remote Control Units
- Calculators

General Description

The HV825 is a high-voltage driver designed for driving EL lamps typically up to 6.0 nF. The input supply voltage range is from 1.0V to 1.6V. The device uses a single inductor and a minimum number of passive components. The typical output voltage that can be applied to the EL lamp is $\pm 56V$.

The HV825 can be enabled/disabled by connecting the R_{SW-Osc} resistor to V_{DD}/GND .

The HV825 has two internal oscillators to drive a switching bipolar junction transistor (BJT), and a high-voltage EL lamp driver. The frequency for the switching BJT is set by an external resistor connected between the R_{SW-Osc} pin and the V_{DD} supply pin. The EL lamp driver frequency is set by an external resistor connected between the R_{EL-Osc} pin and the V_{DD} pin. An external inductor is connected between the L_X and V_{DD} pins. A 0.01 to 0.1 μF , 100V capacitor is connected between the C_S pin and the GND pin. The EL lamp is connected between the V_A pin and the V_B pin.

The switching BJT charges the external inductor and discharges it into the 0.01 to 0.1 μF , 100V capacitor at the C_S pin. The voltage at the C_S pin will start to increase. The outputs V_A and V_B are configured as an H-bridge, and are switching in opposite states to achieve a peak-to-peak voltage of two times the V_{CS} voltage across the EL lamp.

Typical Application Circuit

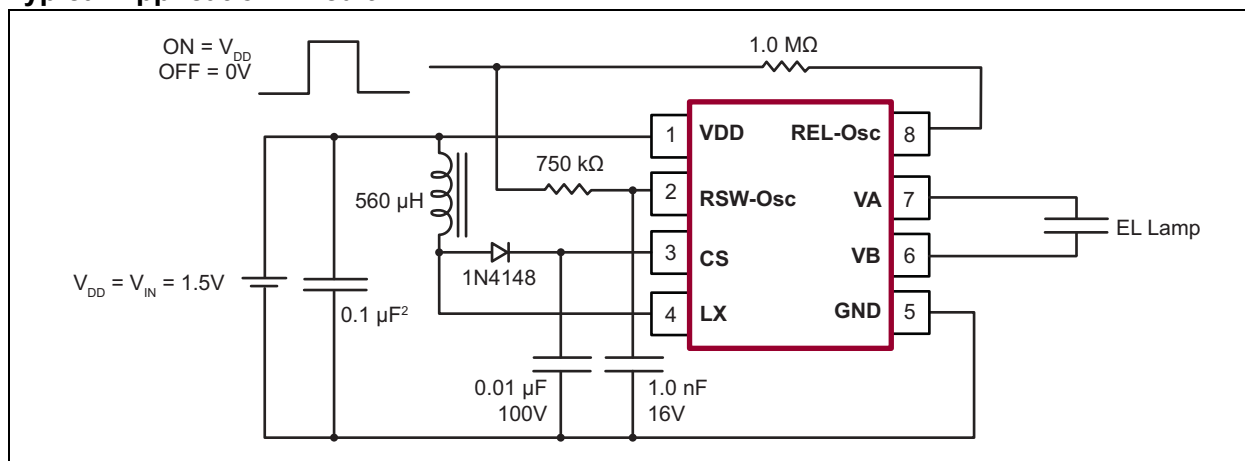

HV825

Package Types

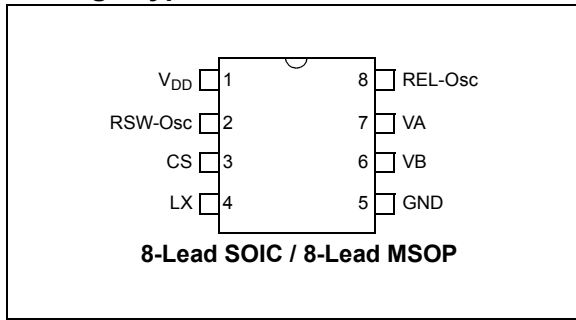

Block Diagram

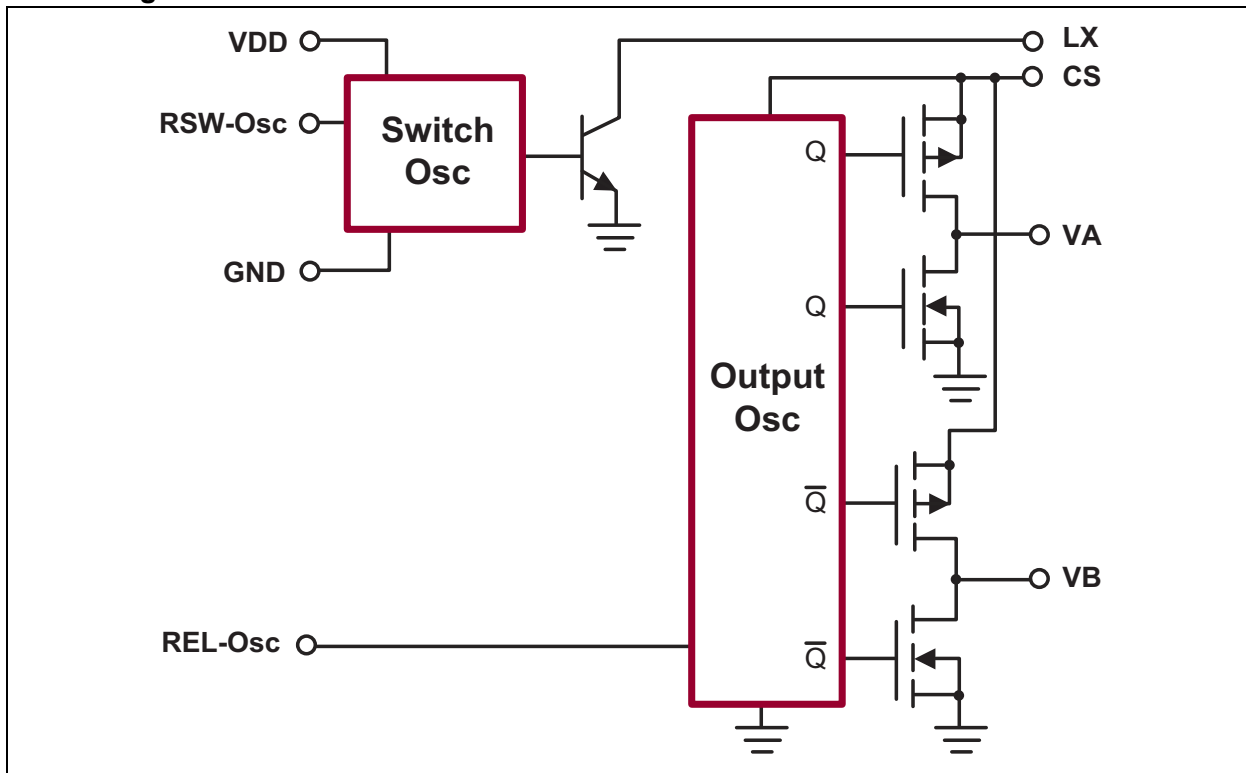

Test Circuit

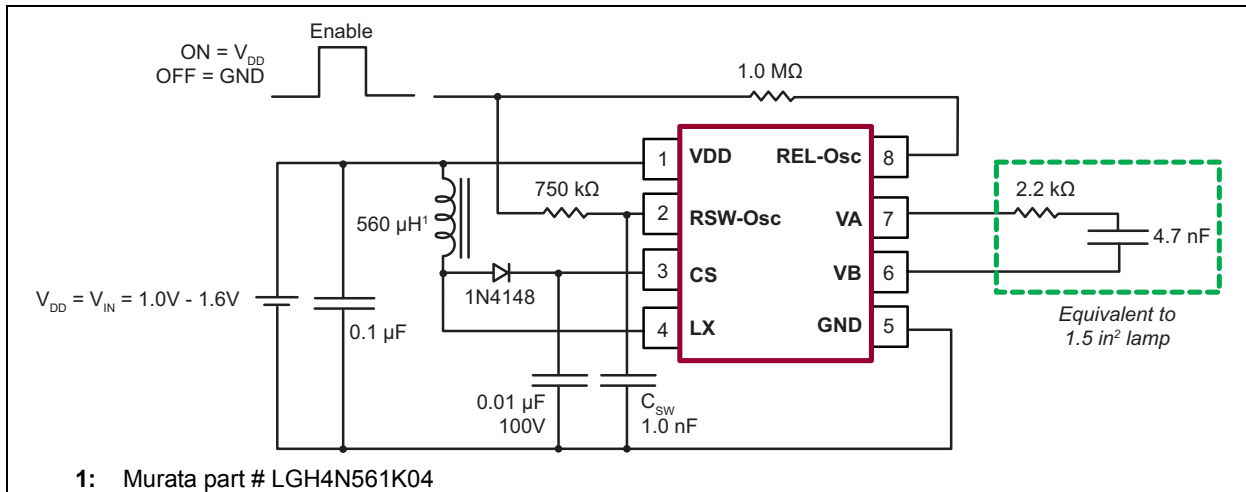

1.0 ELECTRICAL CHARACTERISTICS

Absolute Maximum Ratings^(†)

V _{DD} pin.....	0.5 to 2.5V
Package Power Dissipation (MSOP-8).....	300 mW
Package Power Dissipation (SO-8).....	400 mW
Operating Ambient Temperature Range	-25°C to +85°C
Storage Temperature Range.....	-65°C to +150°C

† **Notice:** Stresses above those listed under “Absolute Maximum Ratings” may cause permanent damage to the device. This is a stress rating only and functional operation of the device at those or any other conditions above those indicated in the operation listings of this specification is not implied. Exposure above maximum rating conditions for extended periods may affect device reliability

DC CHARACTERISTICS

Electrical Specifications: Unless otherwise specified, all specifications apply at T_A = 25°C over recommended operating conditions.

Parameters	Sym.	Min.	Typ.	Max.	Unit	Conditions
On-resistance of switching transistor	R _{ON}	—	—	15	Ω	I = 50 mA
V _{DD} supply current (including inductor current)	I _{IN}	—	30	38	mA	V _{DD} = 1.5V. See test circuit.
Quiescent V _{DD} supply current	I _{DDQ}	—	—	1.0	μA	R _{SW-OSC} = GND
Output voltage on V _{CS}	V _{CS}	52	56	62	V	V _{DD} = 1.5V. See test circuit.
Differential output voltage across lamp	V _{A-B}	104	112	124	V	V _{DD} = 1.5V. See test circuit.
V _{A-B} output drive frequency	f _{EL}	400	—	—	Hz	V _{DD} = 1.5V. See test circuit.
Switching transistor frequency	f _{SW}	—	30	—	KHz	V _{DD} = 1.5V. See test circuit.
Switching transistor duty cycle	D	—	88	—	%	
Recommended Operating Conditions						
Supply voltage	V _{DD}	1.0	—	1.6	V	
Load capacitance	C _L	0	6	—	nF	
Operating temperature	T _A	-25	—	+85	°C	
Enable/Disable Table						
Low-level input voltage to R _{SW-OSC} resistor	V _{IL}	0	—	0.2	V	V _{DD} = 1.0–1.6V
High-level input voltage to R _{SW-OSC} resistor	V _{IH}	V _{DD} -0.5	—	V _{DD}	V	V _{DD} = 1.0–1.6V

Typical Thermal Resistance

Package	Θ _{ja}
8-Lead SOIC	101°C/W
8-Lead MSOP	216°C/W

2.0 APPLICATION INFORMATION

2.1 Typical Performance

Table 2-1 shows the performance of the typical application circuit.

TABLE 2-1: TYPICAL PERFORMANCE

Lamp Size	V _{IN}	I _{DD}	V _{CS}	f _{EL}	Brightness
1.5 in ²	1.5V	30 mA	56V	450 Hz	3.65 ft-Im
Note: Results use Murata part # LQH4N561K04, max DC resistance = 14.5Ω					

2.2 Diode

A fast reverse recovery diode is used (1N4148 or equivalent).

2.3 C_S Capacitor

A 0.01 to 0.1 μF, 100V capacitor to GND is used to store the energy transferred from the inductor.

2.4 R_{EL-Osc} Resistor

The lamp frequency is controlled via the R_{EL-Osc} pin. The lamp frequency increases as R_{EL-Osc} decreases. As the lamp frequency increases, the amount of current drawn from the battery will increase and the output voltage V_{CS} will decrease. This is because the lamp will draw more current from V_{CS} when driven at higher frequencies.

In general, as the lamp size increases, a larger R_{EL-Osc} is recommended to provide higher V_{CS}. However, the color of the lamp is dependent upon its frequency and the shade of the color will change slightly with different frequencies.

2.5 R_{SW-Osc} Resistor

The switching frequency of the inductor is controlled via the R_{SW-Osc}. The switching frequency increases as the R_{SW-Osc} decreases. As the switching frequency increases, the amount of current drawn from the battery will decrease and the output voltage V_{CS} will also decrease.

2.6 L_X Inductor

The inductor L_X is used to boost the low input voltage. When the internal switch is on, the inductor is being charged. When the internal switch is off, the charge in the inductor will be transferred to the high voltage capacitor C_S. The energy stored in the capacitor is connected to the internal H-bridge and therefore to the lamp. In general, smaller value inductors, which can handle more current, are more suitable to drive larger lamps. As the inductor value decreases, the switching frequency of the inductor (controlled by R_{SW-Osc}) should be increased to avoid saturation.

The test circuit uses a Murata (LQH4N561) 560 μH inductor. Using different inductor values or inductors from different manufacturers will affect the performance.

As the inductor value decreases, smaller R_{SW-Osc} values should be used. This will prevent inductor saturation. An inductor with the same inductance value (560 μH) but lower series resistance will charge faster.

The R_{SW-Osc} resistor value needs to be decreased to prevent inductor saturation and high current consumption.

2.7 C_{SW} Capacitor

A 1 nF capacitor is recommended from the R_{SW-Osc} pin to GND. This capacitor is used to shunt any switching noise that may couple into the R_{SW-Osc} pin. A C_{SW} larger than 1 nF is not recommended.

3.0 PACKAGING INFORMATION

3.1 Package Marking Information

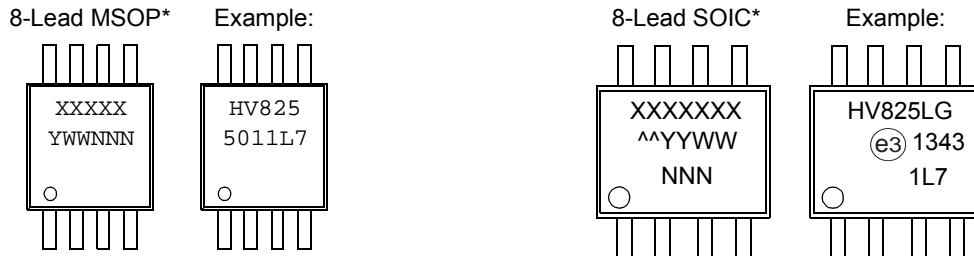

Legend:	XX...X	Product Code or Customer-specific information
	Y	Year code (last digit of calendar year)
	YY	Year code (last 2 digits of calendar year)
	WW	Week code (week of January 1 is week '01')
	NNN	Alphanumeric traceability code
	(e3)	Pb-free JEDEC® designator for Matte Tin (Sn)
	*	This package is Pb-free. The Pb-free JEDEC designator (e3) can be found on the outer packaging for this package.
Note:	In the event the full Microchip part number cannot be marked on one line, it will be carried over to the next line, thus limiting the number of available characters for product code or customer-specific information. Package may or not include the corporate logo.	

8-Lead SOIC (Narrow Body) Package Outline (LG/TG) 4.90x3.90mm body, 1.75mm height (max), 1.27mm pitch

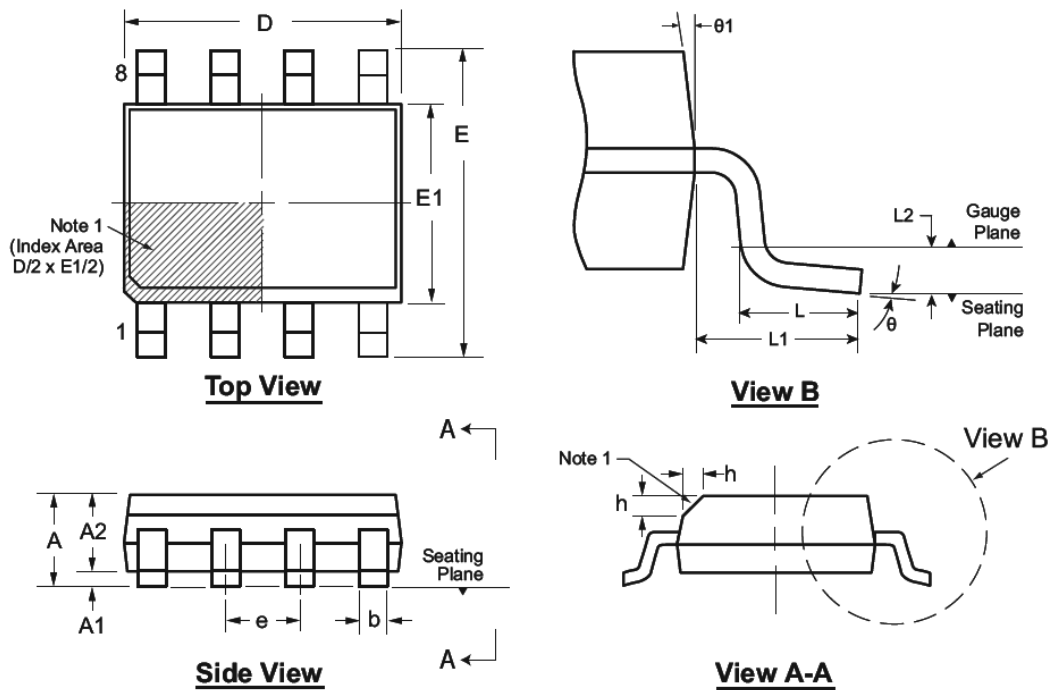

Note: For the most current package drawings, see the Microchip Packaging Specification at www.microchip.com/packaging

Note:

1. This chamfer feature is optional. A Pin 1 identifier must be located in the index area indicated. The Pin 1 identifier can be: a molded mark/identifier; an embedded metal marker; or a printed indicator.

Symbol		A	A1	A2	b	D	E	E1	e	h	L	L1	L2	θ	θ_1
Dimension (mm)	MIN	1.35*	0.10	1.25	0.31	4.80*	5.80*	3.80*	1.27 BSC	0.25	0.40	1.04 REF	0.25 BSC	0°	5°
	NOM	-	-	-	-	4.90	6.00	3.90		-	-			-	-
	MAX	1.75	0.25	1.65*	0.51	5.00*	6.20*	4.00*		0.50	1.27			8°	15°

JEDEC Registration MS-012, Variation AA, Issue E, Sept. 2005.

* This dimension is not specified in the JEDEC drawing.

Drawings are not to scale.

8-Lead MSOP Package Outline (MG) 3.00x3.00mm body, 1.10mm height (max), 0.65mm pitch

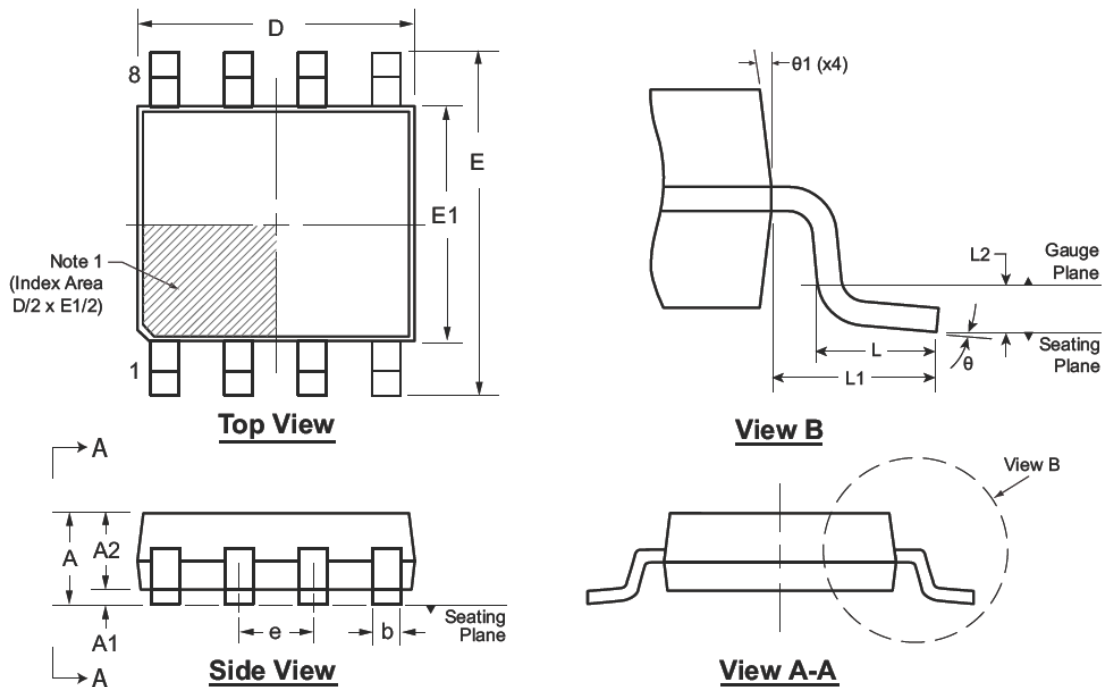

Note: For the most current package drawings, see the Microchip Packaging Specification at www.microchip.com/packaging.

Note:

1. A Pin 1 identifier must be located in the index area indicated. The Pin 1 identifier can be: a molded mark/identifier; an embedded metal marker; or a printed indicator.

Symbol	A	A1	A2	b	D	E	E1	e	L	L1	L2	θ	$\theta1$	
Dimension (mm)	MIN	0.75*	0.00	0.75	0.22	2.80*	4.65*	2.80*	0.65 BSC	0.95 REF	0.25 BSC	0°	5°	
	NOM	-	-	0.85	-	3.00	4.90	3.00				0.40	-	-
	MAX	1.10	0.15	0.95	0.38	3.20*	5.15*	3.20*				0.60	8°	15°

JEDEC Registration MO-187, Variation AA, Issue E, Dec. 2004.

* This dimension is not specified in the JEDEC drawing.

Drawings are not to scale.

APPENDIX A: REVISION HISTORY

Revision A (November 2015)

- Initial release of this document in the Microchip format. This replaces version CO72913.

PRODUCT IDENTIFICATION SYSTEM

To order or obtain information, e.g., on pricing or delivery, refer to the factory or the listed sales office.

<u>PART NO.</u>	<u>XX</u>	-	<u>X</u>	-	<u>X</u>
Device	Package Options		Environmental		Media Type
Device:	HV825	=	High Voltage EL Lamp Driver IC		
Package:	LG	=	8-lead SOIC		
	MG	=	8-lead MSOP		
Environmental:	G	=	Lead (Pb)-free/ROHS-compliant Package		
Media Type:	(blank)	=	2500/Reel for LG and MG packages		

Examples:

a) HV825LG-G: High Voltage EL Lamp Driver IC
8-lead SOIC package, 2500/reel

b) HV825MG-G: High Voltage EL Lamp Driver IC
8-lead MSOP package, 2500/reel

HV825

NOTES:

Note the following details of the code protection feature on Microchip devices:

- Microchip products meet the specification contained in their particular Microchip Data Sheet.
- Microchip believes that its family of products is one of the most secure families of its kind on the market today, when used in the intended manner and under normal conditions.
- There are dishonest and possibly illegal methods used to breach the code protection feature. All of these methods, to our knowledge, require using the Microchip products in a manner outside the operating specifications contained in Microchip's Data Sheets. Most likely, the person doing so is engaged in theft of intellectual property.
- Microchip is willing to work with the customer who is concerned about the integrity of their code.
- Neither Microchip nor any other semiconductor manufacturer can guarantee the security of their code. Code protection does not mean that we are guaranteeing the product as “unbreakable.”

Code protection is constantly evolving. We at Microchip are committed to continuously improving the code protection features of our products. Attempts to break Microchip's code protection feature may be a violation of the Digital Millennium Copyright Act. If such acts allow unauthorized access to your software or other copyrighted work, you may have a right to sue for relief under that Act.

Information contained in this publication regarding device applications and the like is provided only for your convenience and may be superseded by updates. It is your responsibility to ensure that your application meets with your specifications. MICROCHIP MAKES NO REPRESENTATIONS OR WARRANTIES OF ANY KIND WHETHER EXPRESS OR IMPLIED, WRITTEN OR ORAL, STATUTORY OR OTHERWISE, RELATED TO THE INFORMATION, INCLUDING BUT NOT LIMITED TO ITS CONDITION, QUALITY, PERFORMANCE, MERCHANTABILITY OR FITNESS FOR PURPOSE. Microchip disclaims all liability arising from this information and its use. Use of Microchip devices in life support and/or safety applications is entirely at the buyer's risk, and the buyer agrees to defend, indemnify and hold harmless Microchip from any and all damages, claims, suits, or expenses resulting from such use. No licenses are conveyed, implicitly or otherwise, under any Microchip intellectual property rights unless otherwise stated.

Trademarks

The Microchip name and logo, the Microchip logo, dsPIC, FlashFlex, flexPWR, JukeBlox, KEELOQ, KEELOQ logo, Klear, LANCheck, MediaLB, MOST, MOST logo, MPLAB, OptoLyzer, PIC, PICSTART, PIC³² logo, RightTouch, SpyNIC, SST, SST Logo, SuperFlash and UNI/O are registered trademarks of Microchip Technology Incorporated in the U.S.A. and other countries.

The Embedded Control Solutions Company and mTouch are registered trademarks of Microchip Technology Incorporated in the U.S.A.

Analog-for-the-Digital Age, BodyCom, chipKIT, chipKIT logo, CodeGuard, dsPICDEM, dsPICDEM.net, ECAN, In-Circuit Serial Programming, ICSP, Inter-Chip Connectivity, KlearNet, KlearNet logo, MiWi, motorBench, MPASM, MPF, MPLAB Certified logo, MPLIB, MPLINK, MultiTRAK, NetDetach, Omniscient Code Generation, PICDEM, PICDEM.net, PICKit, PICTail, RightTouch logo, REAL ICE, SQI, Serial Quad I/O, Total Endurance, TSHARC, USBCheck, VariSense, ViewSpan, WiperLock, Wireless DNA, and ZENA are trademarks of Microchip Technology Incorporated in the U.S.A. and other countries.

SQTP is a service mark of Microchip Technology Incorporated in the U.S.A.

Silicon Storage Technology is a registered trademark of Microchip Technology Inc. in other countries.

GestIC is a registered trademark of Microchip Technology Germany II GmbH & Co. KG, a subsidiary of Microchip Technology Inc., in other countries.

All other trademarks mentioned herein are property of their respective companies.

© 2015, Microchip Technology Incorporated, Printed in the U.S.A., All Rights Reserved.

ISBN: 978-1-5224-0001-1

QUALITY MANAGEMENT SYSTEM
CERTIFIED BY DNV
== ISO/TS 16949 ==

Microchip received ISO/TS-16949:2009 certification for its worldwide headquarters, design and wafer fabrication facilities in Chandler and Tempe, Arizona; Gresham, Oregon and design centers in California and India. The Company's quality system processes and procedures are for its PIC[®] MCUs and dsPIC[®] DSCs, KEELOQ[®] code hopping devices, Serial EEPROMs, microperipherals, nonvolatile memory and analog products. In addition, Microchip's quality system for the design and manufacture of development systems is ISO 9001:2000 certified.



MICROCHIP

Worldwide Sales and Service

AMERICAS

Corporate Office
2355 West Chandler Blvd.
Chandler, AZ 85224-6199
Tel: 480-792-7200
Fax: 480-792-7277
Technical Support:
<http://www.microchip.com/support>
Web Address:
www.microchip.com

Atlanta
Duluth, GA
Tel: 678-957-9614
Fax: 678-957-1455

Austin, TX
Tel: 512-257-3370

Boston
Westborough, MA
Tel: 774-760-0087
Fax: 774-760-0088

Chicago
Itasca, IL
Tel: 630-285-0071
Fax: 630-285-0075

Cleveland
Independence, OH
Tel: 216-447-0464
Fax: 216-447-0643

Dallas
Addison, TX
Tel: 972-818-7423
Fax: 972-818-2924

Detroit
Novi, MI
Tel: 248-848-4000

Houston, TX
Tel: 281-894-5983

Indianapolis
Noblesville, IN
Tel: 317-773-8323
Fax: 317-773-5453

Los Angeles
Mission Viejo, CA
Tel: 949-462-9523
Fax: 949-462-9608

New York, NY
Tel: 631-435-6000

San Jose, CA
Tel: 408-735-9110

Canada - Toronto
Tel: 905-673-0699
Fax: 905-673-6509

ASIA/PACIFIC

Asia Pacific Office
Suites 3707-14, 37th Floor
Tower 6, The Gateway
Harbour City, Kowloon

Hong Kong
Tel: 852-2943-5100
Fax: 852-2401-3431

Australia - Sydney
Tel: 61-2-9868-6733
Fax: 61-2-9868-6755

China - Beijing
Tel: 86-10-8569-7000
Fax: 86-10-8528-2104

China - Chengdu
Tel: 86-28-8665-5511
Fax: 86-28-8665-7889

China - Chongqing
Tel: 86-23-8980-9588
Fax: 86-23-8980-9500

China - Dongguan
Tel: 86-769-8702-9880

China - Hangzhou
Tel: 86-571-8792-8115
Fax: 86-571-8792-8116

China - Hong Kong SAR
Tel: 852-2943-5100
Fax: 852-2401-3431

China - Nanjing
Tel: 86-25-8473-2460
Fax: 86-25-8473-2470

China - Qingdao
Tel: 86-532-8502-7355
Fax: 86-532-8502-7205

China - Shanghai
Tel: 86-21-5407-5533
Fax: 86-21-5407-5066

China - Shenyang
Tel: 86-24-2334-2829
Fax: 86-24-2334-2393

China - Shenzhen
Tel: 86-755-8864-2200
Fax: 86-755-8203-1760

China - Wuhan
Tel: 86-27-5980-5300
Fax: 86-27-5980-5118

China - Xian
Tel: 86-29-8833-7252
Fax: 86-29-8833-7256

ASIA/PACIFIC

China - Xiamen
Tel: 86-592-2388138
Fax: 86-592-2388130

China - Zhuhai
Tel: 86-756-3210040
Fax: 86-756-3210049

India - Bangalore
Tel: 91-80-3090-4444
Fax: 91-80-3090-4123

India - New Delhi
Tel: 91-11-4160-8631
Fax: 91-11-4160-8632

India - Pune
Tel: 91-20-3019-1500

Japan - Osaka
Tel: 81-6-6152-7160
Fax: 81-6-6152-9310

Japan - Tokyo
Tel: 81-3-6880-3770
Fax: 81-3-6880-3771

Korea - Daegu
Tel: 82-53-744-4301
Fax: 82-53-744-4302

Korea - Seoul
Tel: 82-2-554-7200
Fax: 82-2-558-5932 or
82-2-558-5934

Malaysia - Kuala Lumpur
Tel: 60-3-6201-9857
Fax: 60-3-6201-9859

Malaysia - Penang
Tel: 60-4-227-8870
Fax: 60-4-227-4068

Philippines - Manila
Tel: 63-2-634-9065
Fax: 63-2-634-9069

Singapore
Tel: 65-6334-8870
Fax: 65-6334-8850

Taiwan - Hsin Chu
Tel: 886-3-5778-366
Fax: 886-3-5770-955

Taiwan - Kaohsiung
Tel: 886-7-213-7828

Taiwan - Taipei
Tel: 886-2-2508-8600
Fax: 886-2-2508-0102

Thailand - Bangkok
Tel: 66-2-694-1351
Fax: 66-2-694-1350

EUROPE

Austria - Wels
Tel: 43-7242-2244-39
Fax: 43-7242-2244-393

Denmark - Copenhagen
Tel: 45-4450-2828
Fax: 45-4485-2829

France - Paris
Tel: 33-1-69-53-63-20
Fax: 33-1-69-30-90-79

Germany - Dusseldorf
Tel: 49-2129-3766400

Germany - Karlsruhe
Tel: 49-721-625370

Germany - Munich
Tel: 49-89-627-144-0
Fax: 49-89-627-144-44

Italy - Milan
Tel: 39-0331-742611
Fax: 39-0331-466781

Italy - Venice
Tel: 39-049-7625286

Netherlands - Drunen
Tel: 31-416-690399
Fax: 31-416-690340

Poland - Warsaw
Tel: 48-22-3325737

Spain - Madrid
Tel: 34-91-708-08-90
Fax: 34-91-708-08-91



Sweden - Stockholm
Tel: 46-8-5090-4654

UK - Wokingham
Tel: 44-118-921-5800
Fax: 44-118-921-5820

07/14/15

Looking for pricing, stock, or lifecycle information?

Click below to explore more details on WIN SOURCE:

-  [View HV825LG on WIN SOURCE](#)
-  [Microchip Technology](#) Information

Optimize Your Supply Chain with WIN SOURCE Solutions

-  Global Sourcing Solution
-  Obsolete Management
-  Cost Control Management
-  Shortage Management
-  Alternative Solution
-  Excess Inventory Management