



# THE DATASHEET OF HMC473MS8ETR





## GaAs MMIC VOLTAGE VARIABLE ATTENUATOR, 0.45 - 2.2 GHz

### Typical Applications

The HMC473MS8 / HMC473MS8E is ideal for:

- Cellular, UMTS/3G Infrastructure
- Portable Wireless
- GPS

### Functional Diagram

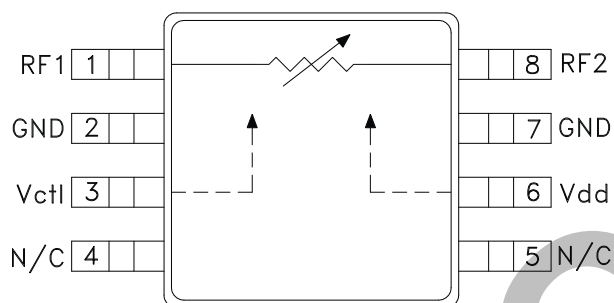

### Features

RoHS Compliant Product

Single Positive Voltage Control: 0 to +3V

High Attenuation Range: 48 dB @ 0.9 GHz

High P1dB Compression Point: +15 dBm

Ultra Small Package: MSOP8

Replaces HMC173MS8

### General Description

The HMC473MS8 & HMC473MS8E are general purpose absorptive voltage variable attenuators in 8-lead MSOP packages. The devices operate with a +3.3V supply voltage and a 0 to +3V control voltage. Unique features include a high dynamic attenuation range of up to 48 dB and excellent power handling performance through all attenuation states. The HMC473MS8 & HMC473MS8E are ideal for operation in wireless applications from 0.45 to 1.6 GHz. Operation from 1.7 to 2.2 GHz is possible with a reduced maximum attenuation of 29 to 32 dB. Improved control voltage linearity vs. attenuation can be achieved with an external driver circuit.

### Electrical Specifications, $T_A = +25^\circ\text{C}$ , $V_{dd} = +3.3\text{Vdc}$ , 50 Ohm System

| Parameter   |                | Min. | Typ. | Max. | Units         |
|---|----------------|------|------|------|---------------|
| Insertion Loss (Min. Atten.)<br>( $V_{ctl} = 0.0\text{Vdc}$ )                             | 0.45 - 0.8 GHz |      | 1.8  | 2.2  | dB            |
|   | 0.8 - 1.0 GHz  |      | 1.9  | 2.3  | dB            |
|   | 1.0 - 1.6 GHz  |      | 2.4  | 2.9  | dB            |
|   | 1.6 - 2.0 GHz  |      | 2.8  | 3.3  | dB            |
|   | 2.0 - 2.2 GHz  |      | 3.0  | 3.5  | dB            |
| Attenuation Range<br>( $V_{ctl} = 0$ to +3 V)   | 0.45 - 0.8 GHz | 34   | 39   |      | dB            |
|   | 0.8 - 1.0 GHz  | 43   | 48   |      | dB            |
|   | 1.0 - 1.6 GHz  | 32   | 37   |      | dB            |
|   | 1.6 - 2.0 GHz  | 27   | 32   |      | dB            |
|   | 2.0 - 2.2 GHz  | 24   | 29   |      | dB            |
| Return Loss<br>( $V_{ctl} = 0$ to +3 V)   | 0.45 - 0.8 GHz |      | 15   |      | dB            |
|   | 0.8 - 1.0 GHz  |      | 14   |      | dB            |
|   | 1.0 - 1.6 GHz  |      | 11   |      | dB            |
|   | 1.6 - 2.0 GHz  |      | 10   |      | dB            |
|   | 2.0 - 2.2 GHz  |      | 9    |      | dB            |
| Input Power for 0.1 dB Compression<br>(0.9 GHz)   | Min Atten.     |      | 20   |      | dBm           |
|   | Atten. >2.0    |      | 5.5  |      | dBm           |
| Input Power for 1.0 dB Compression<br>(0.9 GHz)   | Min Atten.     | 24   | 28   |      | dBm           |
|   | Atten. >2.0    | 11   | 15   |      | dBm           |
| Input Third Order Intercept<br>(0.9 GHz, Two-tone Input Power = +5.0 dBm Each Tone)       | Min Atten.     |      | 47   |      | dBm           |
|   | Atten. >2.0    |      | 20   |      | dBm           |
| Switching Characteristics<br>tRISE, tFALL (10/90% RF)<br>tON, tOFF (50% CTL to 10/90% RF) | 0.45 - 2.2 GHz |      | 1.3  |      | $\mu\text{S}$ |
|   |                |      | 1.5  |      | $\mu\text{S}$ |
|   |                |      |      |      |               |



# HMC473MS8 / 473MS8E

## GaAs MMIC VOLTAGE VARIABLE ATTENUATOR, 0.45 - 2.2 GHz

**Insertion Loss vs. Temperature**

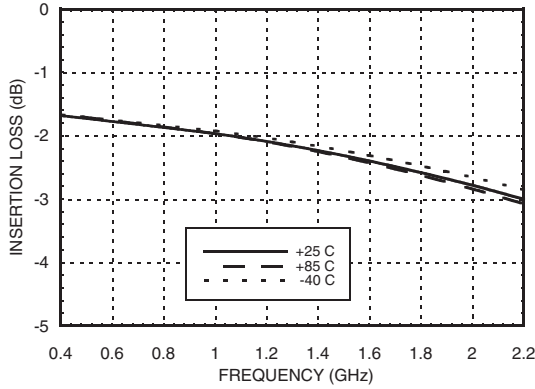

**Return Loss vs. Control Voltage**

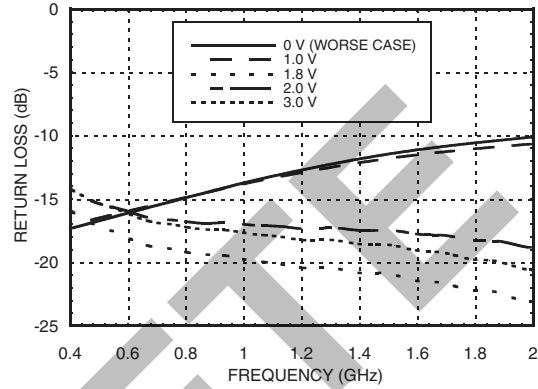

**Input IP3 vs. Control Voltage @ 0.45 GHz**

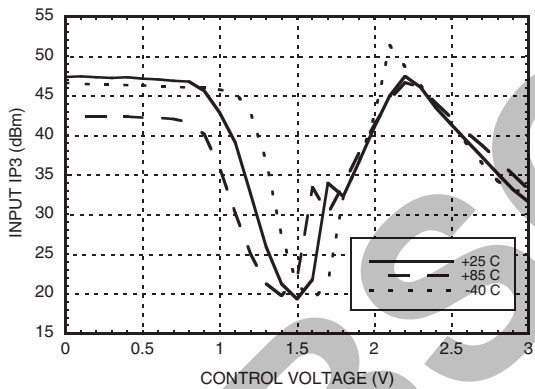

**Input IP3 vs. Control Voltage @ 0.9 GHz**

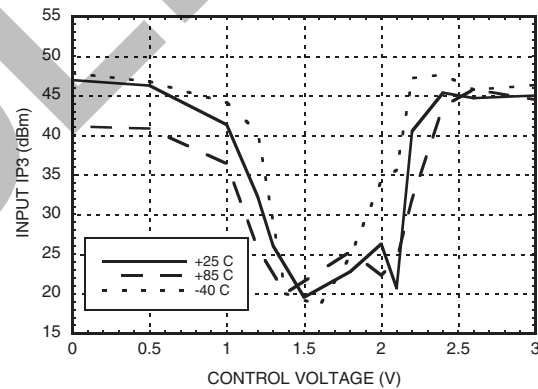

**Input IP3 vs. Control Voltage @ 1.9 GHz**

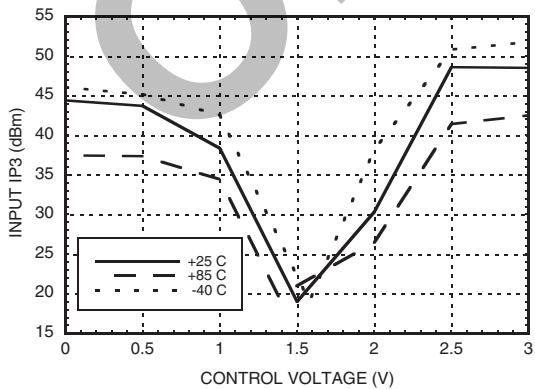

**Input IP3 vs. Control Voltage @ 2.1 GHz**

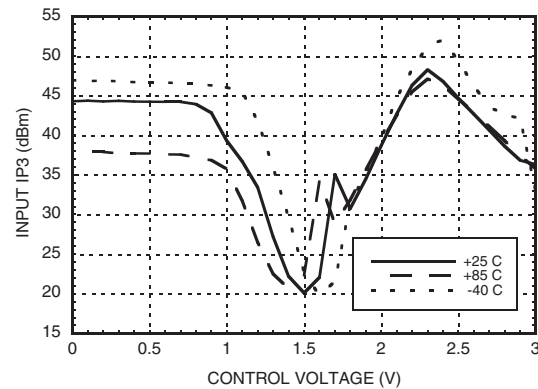

Information furnished by Analog Devices is believed to be accurate and reliable. However, no responsibility is assumed by Analog Devices for its use, nor for any infringements of patents or other rights of third parties that may result from its use. Specifications subject to change without notice. No license is granted by implication or otherwise under any patent or patent rights of Analog Devices. Trademarks and registered trademarks are the property of their respective owners.

For price, delivery, and to place orders: Analog Devices, Inc., One Technology Way, P.O. Box 9106, Norwood, MA 02062-9106 Phone: 781-329-4700 • Order online at [www.analog.com](http://www.analog.com) Application Support: Phone: 1-800-ANALOG-D



**HMC473MS8 / 473MS8E**

**GaAs MMIC VOLTAGE VARIABLE  
ATTENUATOR, 0.45 - 2.2 GHz**

5

ATTENUATORS - SMT

**Relative Attenuation vs.  
Control Voltage @ 0.45 GHz**

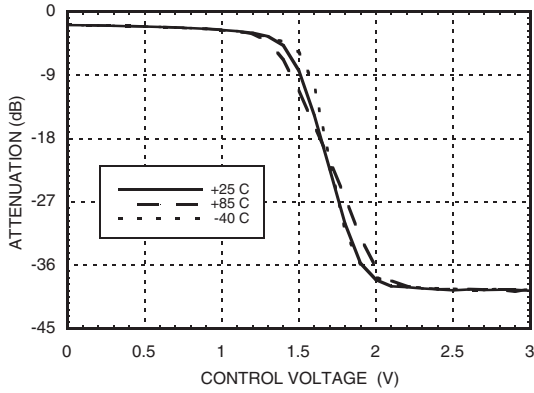

**Return Loss vs.  
Control Voltage @ 0.45 GHz**

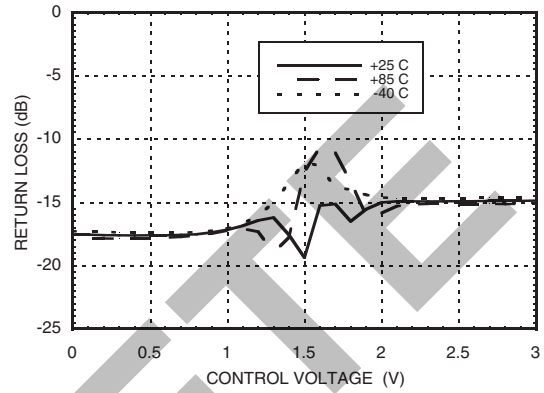

**Relative Attenuation vs.  
Control Voltage @ 0.9 GHz**

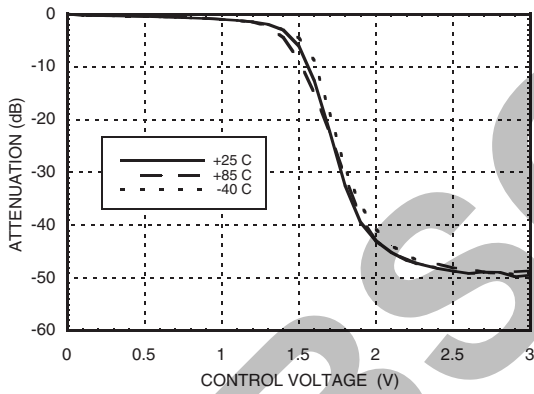

**Return Loss vs.  
Control Voltage @ 0.9 GHz**

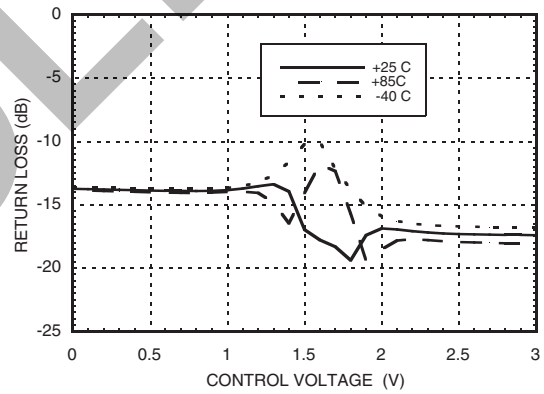

**Relative Attenuation vs.  
Control Voltage @ 1.9 GHz**

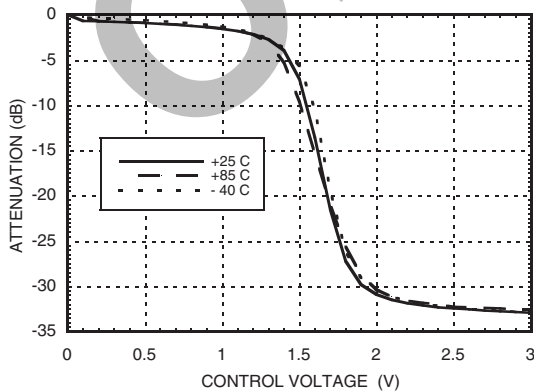

**Return Loss vs.  
Control Voltage @ 1.9 GHz**

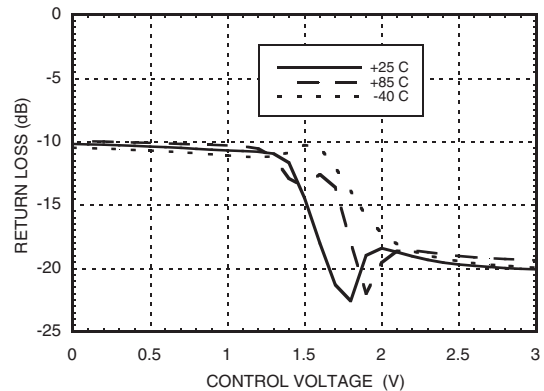

Information furnished by Analog Devices is believed to be accurate and reliable. However, no responsibility is assumed by Analog Devices for its use, nor for any infringements of patents or other rights of third parties that may result from its use. Specifications subject to change without notice. No license is granted by implication or otherwise under any patent or patent rights of Analog Devices. Trademarks and registered trademarks are the property of their respective owners.

For price, delivery, and to place orders: Analog Devices, Inc., One Technology Way, P.O. Box 9106, Norwood, MA 02062-9106 Phone: 781-329-4700 • Order online at [www.analog.com](http://www.analog.com) Application Support: Phone: 1-800-ANALOG-D



**HMC473MS8 / 473MS8E**

**GaAs MMIC VOLTAGE VARIABLE  
ATTENUATOR, 0.45 - 2.2 GHz**

**Relative Attenuation vs.  
Control Voltage @ 2.1 GHz**

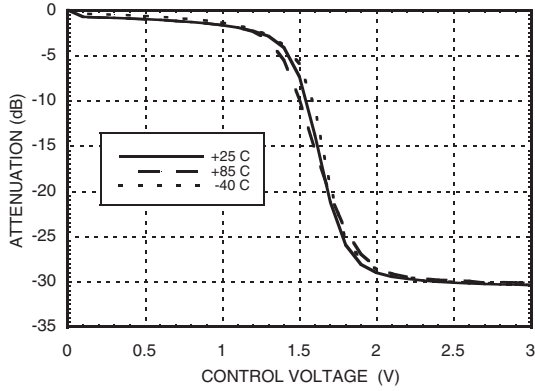

**Return Loss vs.  
Control Voltage @ 2.1 GHz**

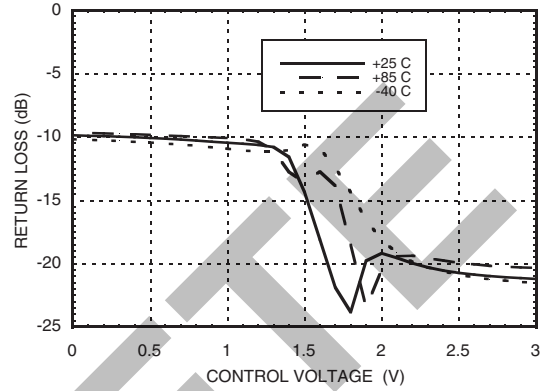

**Relative Attenuation vs. Control Voltage**

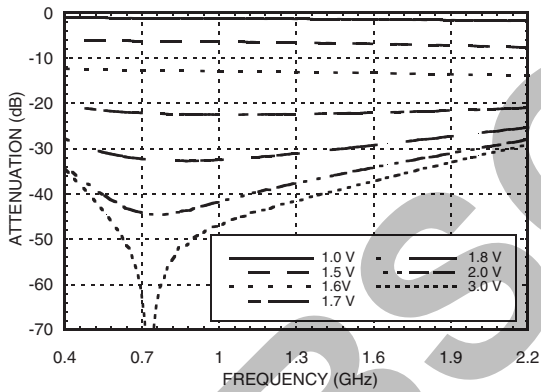

**Worse Case Input P1dB vs. Temperature**

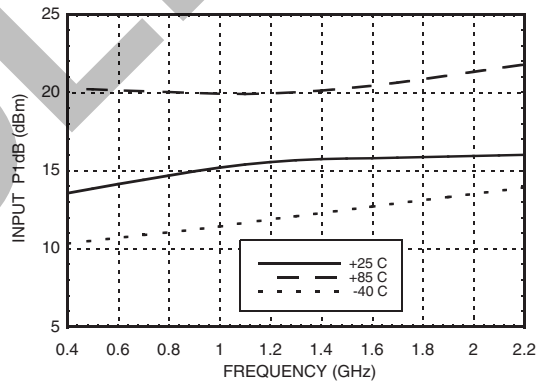

Information furnished by Analog Devices is believed to be accurate and reliable. However, no responsibility is assumed by Analog Devices for its use, nor for any infringements of patents or other rights of third parties that may result from its use. Specifications subject to change without notice. No license is granted by implication or otherwise under any patent or patent rights of Analog Devices. Trademarks and registered trademarks are the property of their respective owners.

For price, delivery, and to place orders: Analog Devices, Inc., One Technology Way, P.O. Box 9106, Norwood, MA 02062-9106 Phone: 781-329-4700 • Order online at [www.analog.com](http://www.analog.com) Application Support: Phone: 1-800-ANALOG-D

**Control and Bias Voltage**

|           |                                     |
|-----------|-------------------------------------|
| $V_{CTL}$ | 0 to +3 Vdc @ 1 $\mu$ A             |
| Vdd       | +3.3 Vdc $\pm$ 0.1 Vdc @ 10 $\mu$ A |

**ELECTROSTATIC SENSITIVE DEVICE  
OBSERVE HANDLING PRECAUTIONS**
**Absolute Maximum Ratings**

|   |                 |                                  |
|---|-----------------|----------------------------------|
| $V_{CTL}$   | -0.2 Vdc to Vdd |                                  |
| Vdd   | +8 Vdc          |                                  |
| Maximum Input Power<br>Vdd = +3.3 Vdc                       | +29 dBm         | Min. Atten.<br>Attenuation >2 dB |
| Channel Temperature (Tc)                                    | 150 °C          |                                  |
| Thermal Resistance (R <sub>TH</sub> )<br>(junction to lead) | 92 °C/W         |                                  |
| Storage Temperature   | -65 to +150 °C  |                                  |
| Operating Temperature                                       | -40 to +85 °C   |                                  |
| ESD Sensitivity (HBM)                                       | Class 1A        |                                  |

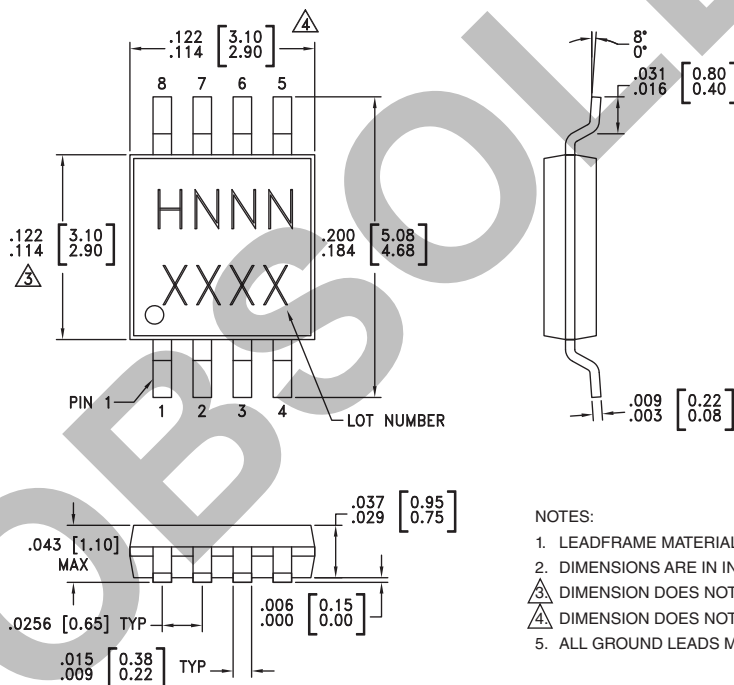
**Outline Drawing**

**NOTES:**

- LEADFRAME MATERIAL: COPPER ALLOY
- DIMENSIONS ARE IN INCHES [MILLIMETERS].
- DIMENSION DOES NOT INCLUDE MOLDFLASH OF 0.15mm PER SIDE.
- DIMENSION DOES NOT INCLUDE MOLDFLASH OF 0.25mm PER SIDE.
- ALL GROUND LEADS MUST BE SOLDERED TO PCB RF GROUND.

**Package Information**

| Part Number | Package Body Material                              | Lead Finish   | MSL Rating          | Package Marking <sup>[3]</sup> |
|-------------|--|---------------|---------------------|--------------------------------|
| HMC473MS8   | Low Stress Injection Molded Plastic                | Sn/Pb Solder  | MSL1 <sup>[1]</sup> | H473<br>XXXX                   |
| HMC473MS8E  | RoHS-compliant Low Stress Injection Molded Plastic | 100% matte Sn | MSL1 <sup>[2]</sup> | H473<br>XXXX                   |



[1] Max peak reflow temperature of 235 °C

[2] Max peak reflow temperature of 260 °C

[3] 4-Digit lot number XXXX

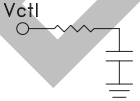

### Pin Descriptions

| Pin Number | Function | Description   | Interface Schematic   |
|------------|----------|---|---|
| 1, 8       | RF1, RF2 | These pins are DC coupled and matched to 50 Ohms. DC blocking capacitors are required. 330pF capacitors are supplied on evaluation board. |  |
| 2, 7       | GND      | Pins must connect to RF ground.   |  |
| 3          | Vctl     | Control voltage   |  |
| 4, 5       | N/C      | No Connection. These pins may be connected to RF ground. Performance will not be affected.  |   |
| 6          | Vdd      | Supply Voltage.   |   |

OBSOLETE



### Attenuation Linearizing Control Circuit

#### For The HMC473MS8 / HMC473MS8E Voltage Variable Attenuator

A driver circuit to improve the attenuation linearity of the HMC473MS8 & HMC473MS8E can be implemented with a simple op-amp configuration. A *breakpoint* linearization circuit will scale the voltage supplied to the control line of the HMC473MS8 & HMC473MS8E, so that a more linear attenuation vs. control voltage slope can be achieved. A -3.3V and +3.3V supply is required.

Diode and resistor values which define the op-amp gain, and breakpoint were selected to optimize a measured production lot of attenuators at 0.9 GHz. R7 may be varied to optimize the performance of any given attenuator. If the input voltage to the linearizing circuit will not drop below 1.0V, the R9 and D2 may be omitted, and this will greatly reduce the overall power consumption of the driver circuit.

The linearizing circuit has been optimized for 0.9 GHz attenuation applications. A similar approach may be used at other frequencies by adjusting R1 - R9 resistor values.

### Application Circuit

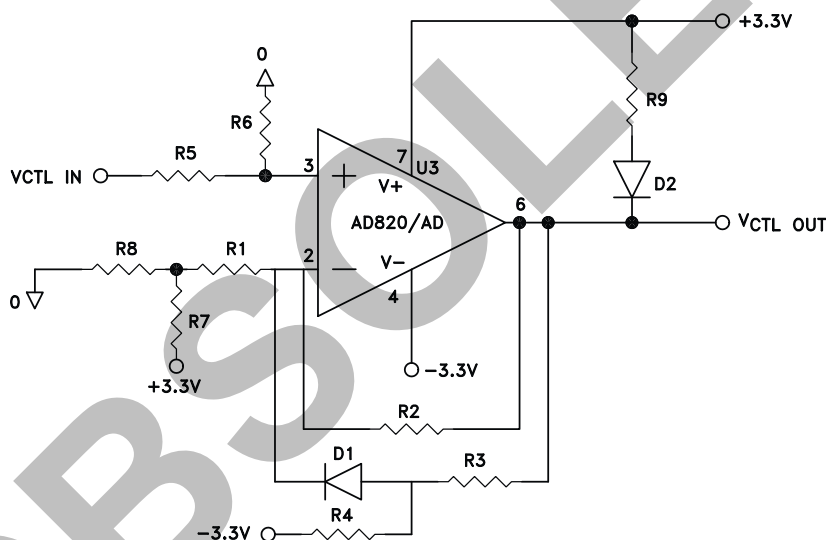

### Required Parts List

| Part   | Description | Manufacturer   |
|--------|-------------|----------------|
| AD822  | Op-Amp      | Analog Devices |
| R1     | 10K ohms    | Panasonic      |
| R2     | 200K ohms   | Panasonic      |
| R3     | 7.5K ohms   | Panasonic      |
| R4     | 39K ohms    | Panasonic      |
| R5     | 220K ohms   | Panasonic      |
| R6     | 91K ohms    | Panasonic      |
| R7     | 910 ohms    | Panasonic      |
| R8     | 51 ohms     | Panasonic      |
| R9     | 100 ohms    | Panasonic      |
| D1, D2 | LL4148 D-35 | Digi-Key       |

**Evaluation PCB**

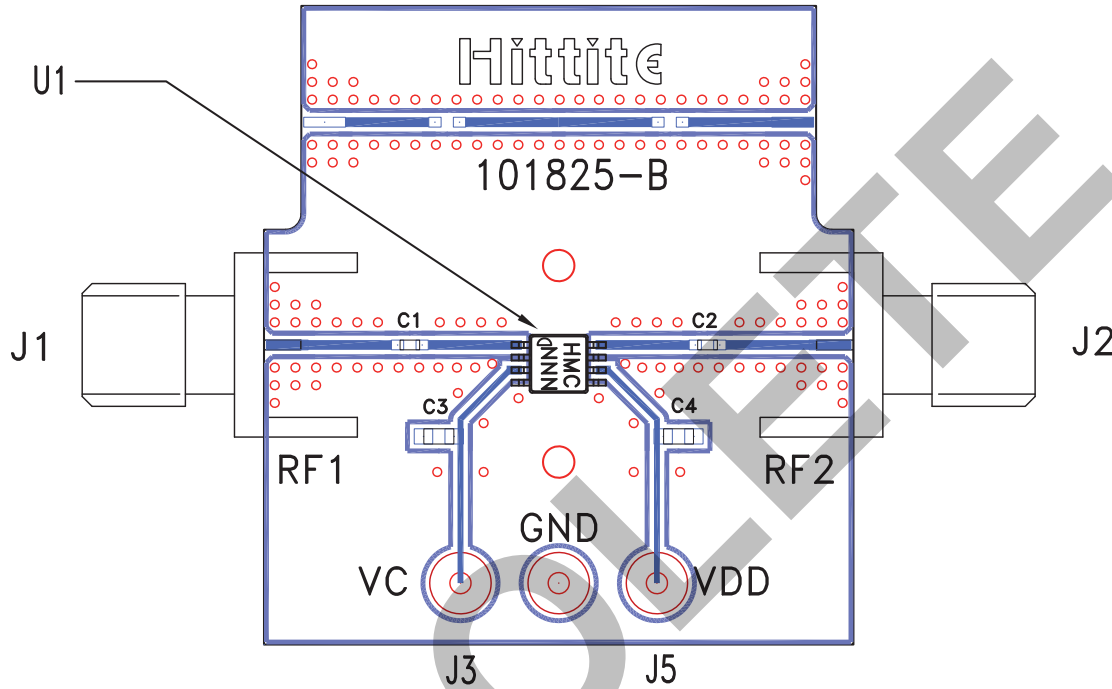

**List of Materials for Evaluation PCB 101827 [1]**

| Item    | Description                |
|---------|----------------------------|
| J1 - J2 | PCB Mount SMA RF Connector |
| J3 - J5 | DC PIN                     |
| C1, C2  | 330pF capacitor, 0402 Pkg. |
| C3, C4  | 10KpF capacitor, 0603 Pkg. |
| U1      | HMC473MS8 / HMC473MS8E     |
| PCB [2] | 101825 Eval Board          |

[1] Reference this number when ordering complete evaluation PCB

[2] Circuit Board Material: Rogers 4350







The circuit board used in the final application should be generated with proper RF circuit design techniques. Signal lines at the RF ports should be 50 ohm impedance and the package ground leads should be connected directly to the PCB RF ground plane, similar to that shown above. The evaluation circuit board shown above is available from Hittite Microwave Corporation upon request.

## Looking for pricing, stock, or lifecycle information?

Click below to explore more details on WIN SOURCE:

-  [View HMC473MS8ETR on WIN SOURCE](#)
-  [Analog Devices Inc. Information](#)

## Optimize Your Supply Chain with WIN SOURCE Solutions

-  Global Sourcing Solution
-  Obsolete Management
-  Cost Control Management
-  Shortage Management
-  Alternative Solution
-  Excess Inventory Management