



**THE DATASHEET OF  
JG0-0023**



# PULSEJACK™

## 1xN Giggle-Up10







[www.pulseeng.com](http://www.pulseeng.com)

### Description:





10/100/1000 Base-T RJ45 1xN Tab-UP Integrated Connector Module (ICM) with or without LEDs, designed to support such applications as: SOHO (ADSL modems), LAN-on-Motherboard (LOM), Hub and Switches.

### Features and Benefits:



-  1xN Tab-UP 10-pin RJ45 with internal magnetics
-  Options: 1x2, 1x4, and 1x6 10/100/1000 Base-T
-  Available with or without LEDs
-  Suitable for CAT 5 & 6 Fast Ethernet Cable or better UTP
-  Internal magnetics are 100% electrically tested for HI-POT and functionality - Minimum 1500Vrms isolation per IEEE 802.3 requirements

### Electrical Performance Summary:

-  Internal magnetics options available
-  Meets IEEE 802.3 specification
-  350µH minimum OCL with 8mA bias current
-  High performance for maximum EMI suppression

### Electrical Specifications @ 25°C — Operating Temperature 0°C to +70°C

Part Number	Tab Option	LEDs <sup>3</sup> L/R	Insertion Loss TX/RX (dB TYP)	Return Loss (dB TYP)				Crosstalk (dB TYP)			Common Mode Rejection (dB TYP)		Hipot (MIN)
				1-100 MHz	1-10 MHz	30 MHz	60-80 MHz	1-10 MHz	30-60 MHz	60-100 MHz	1-125 MHz	125-500 MHz	
JG0-0023 (1x2)	UP	G/G	-1.0	-20	-16	-12	-40	-35	-30	-30	-20	1500 Vrms	
JG0-0024 (1x2)	UP	G/G	-1.0	-20	-16	-12	-40	-35	-30	-30	-20	1500Vrms	
JG0-0025 (1x4)	UP	G/G	-1.0	-20	-16	-12	-40	-35	-30	-30	-20	1500Vrms	
JG0-0026 (1x4)	UP	G/G	-1.0	-20	-16	-12	-40	-35	-30	-30	-20	1500Vrms	
JG0-0027 (1x6)	UP	G/G	-1.0	-20	-16	-12	-40	-35	-30	-30	-20	1500Vrms	
JG0-0028 (1x8)	UP	G/G	-1.0	-20	-16	-12	-40	-35	-30	-30	-20	1500Vrms	

#### Notes:

1. Both transmit and receive channels meet IEEE 802.3 specifications.
2. Different electrical and mechanical specifications can be accommodated. Contact Pulse Applications Engineering.
3. LEDs Left/Right: G = green.

### RJ45 Durability Testing Rating

Part Number	Mating Force (MAX)	Unmating Force (MAX)	Durability	Plug to Jack Retention (MIN)
JG Series	5 lbs./2.268 kgs.	5 lbs./2.268 kgs.	750 Insertions	20 lbs./9.072 kgs.

### RJ45 Material Specification

Part Number	Shield		Contact			Housing		MSL <sup>3</sup> Rating
	Material	Finish	Material	Plating Area	Solder Area	Material	Specification	
JG Series	Brass	20-40µ inches thick nickel over Brass	Phosphor Bronze	30µ inches gold over 30-80µ inches nickel	75-300µ inches tin-lead over 75-300µ inches nickel	Thermoplastic	UL 94 V-0	1

1. All connector part numbers starting with the series prefix JG comply to the above limits.
2. Connector dimensions comply with FCC part 68 dimension requirements.
3. MSL = Moisture Sensitivity Level rating from 1 to 5 (highest rating = 1, lowest rating = 5).

### Mechanical

JG0-0023/24

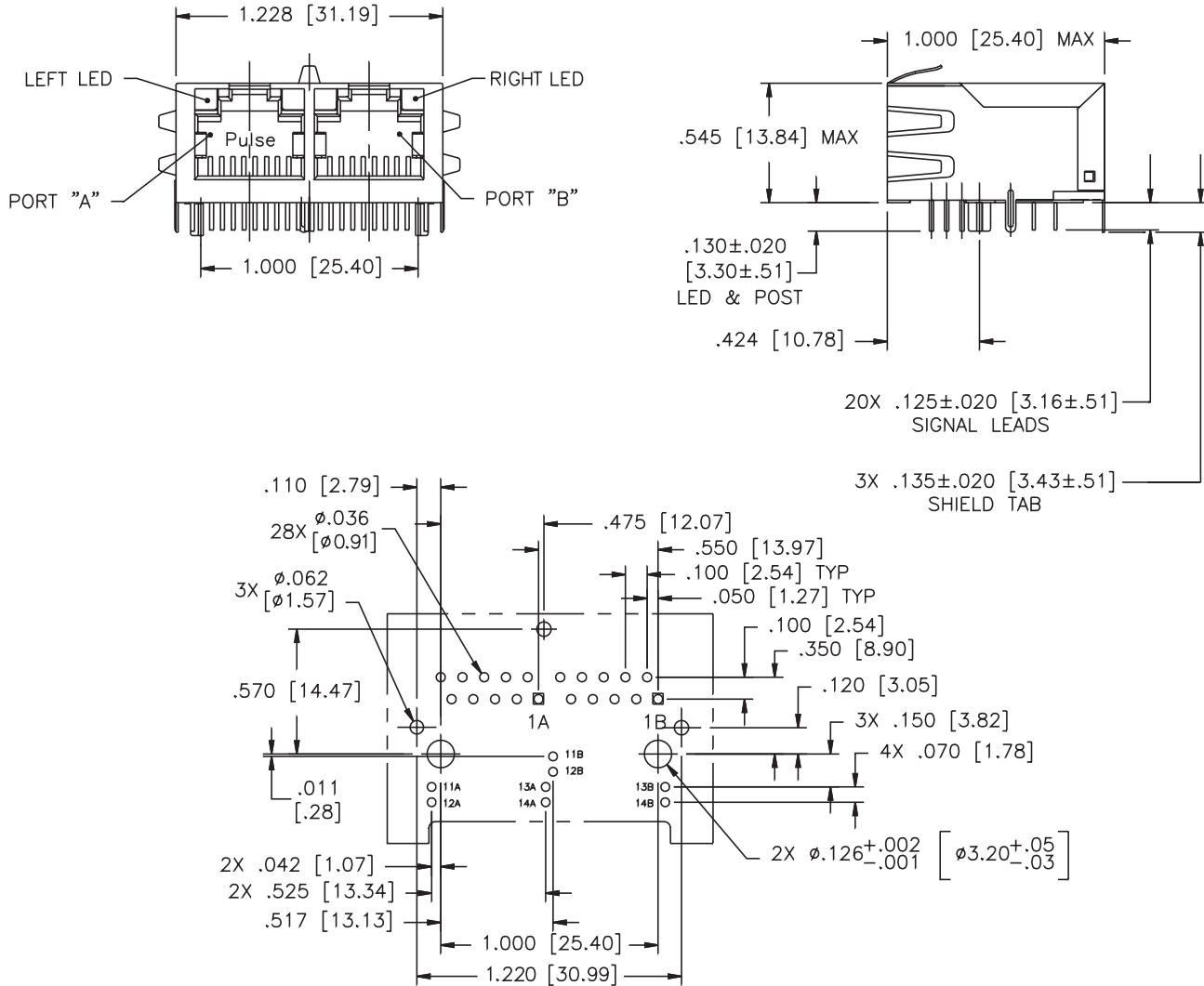

SUGGESTED PC BOARD LAYOUT VIEWED FROM COMPONENT SIDE  
 PCB LAYOUT DIMENSIONS TO BE  $\pm .003$  UNLESS OTHERWISE SPECIFIED

### Mechanical

**JG0-0025/26**

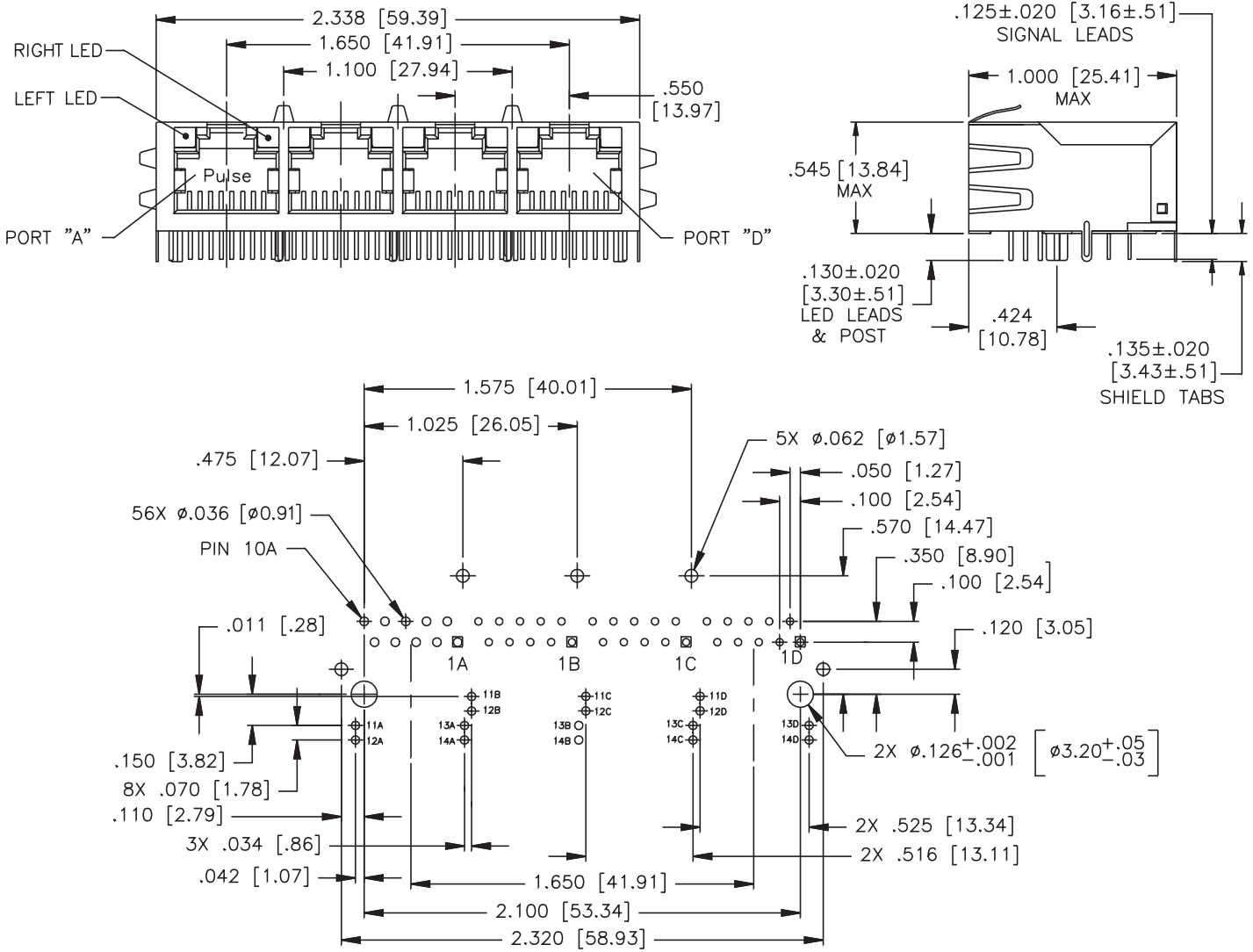

PC Board Layout Component Side Shown  
PCB LAYOUT DIMENSIONS TO BE  $\pm .003$  UNLESS OTHERWISE SPECIFIED

### Mechanical

JG0-0027

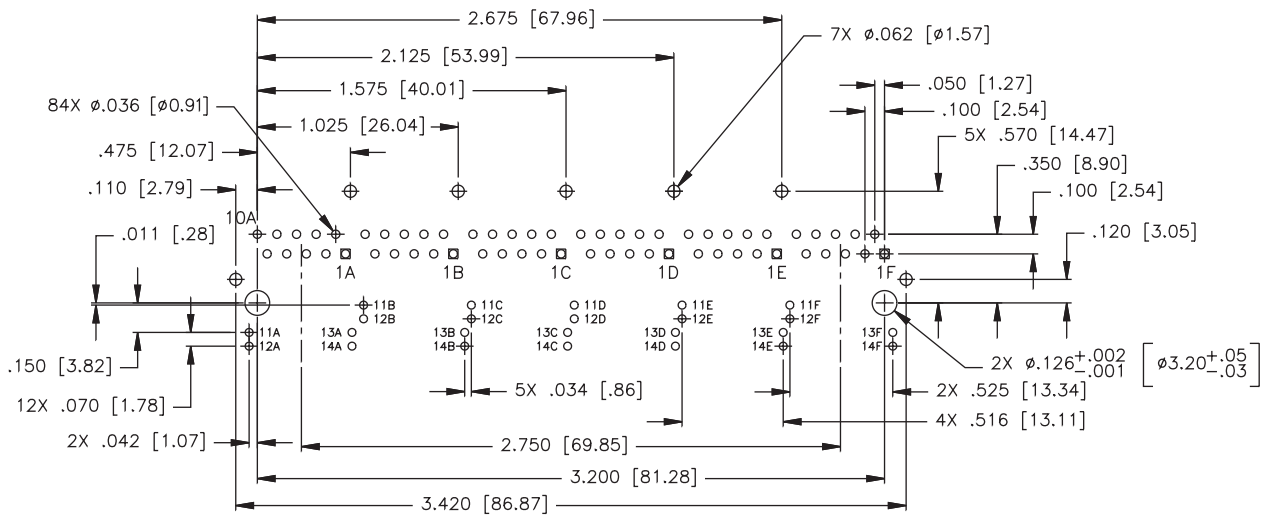
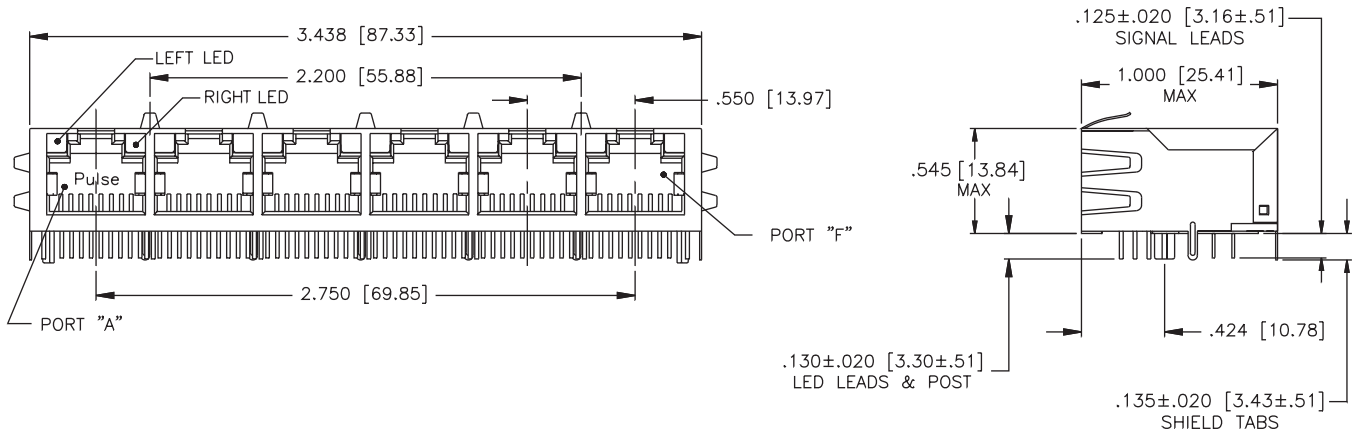

### Mechanical

**JG0-0028**

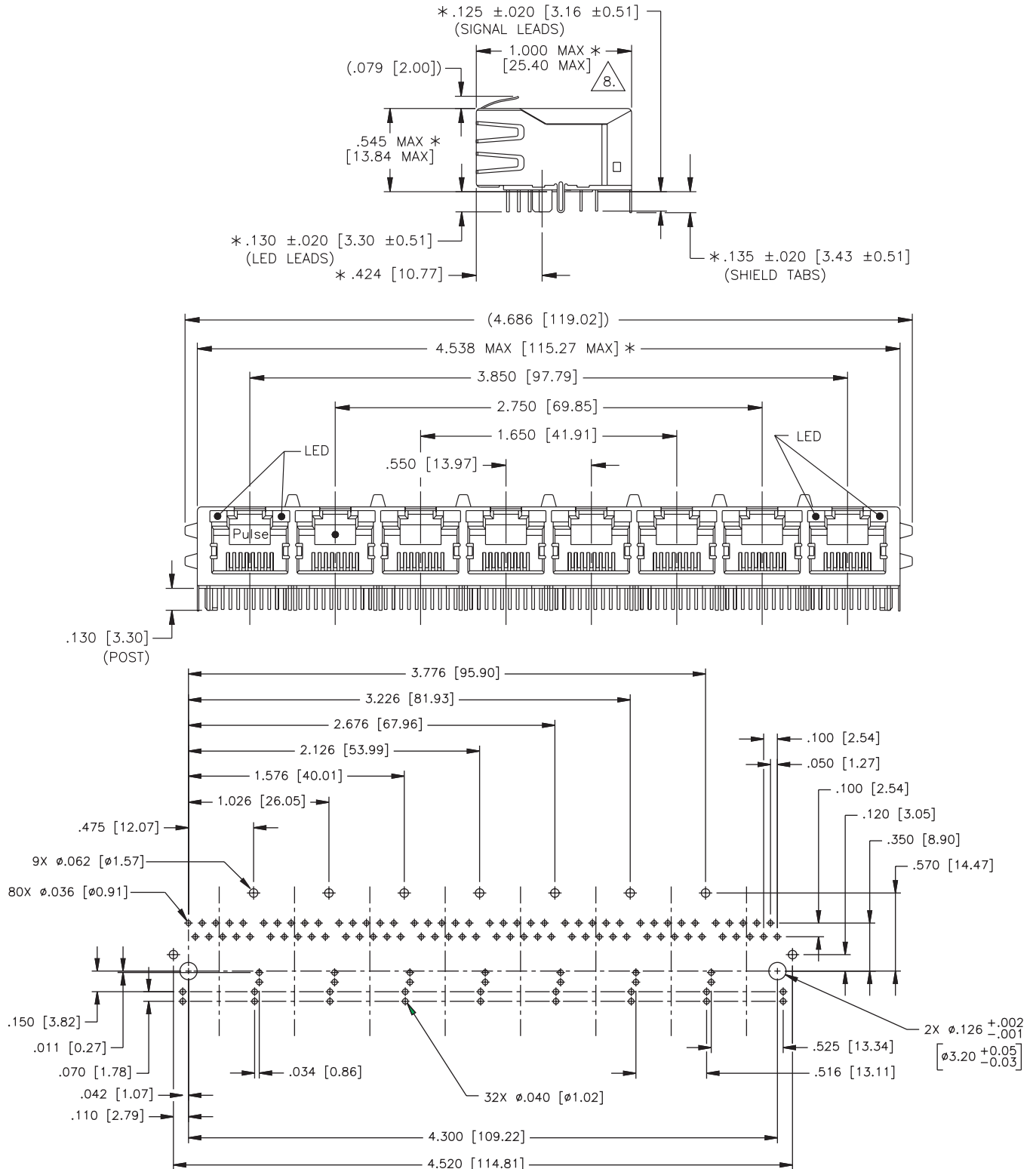

### Schematic

#### JG0-002X

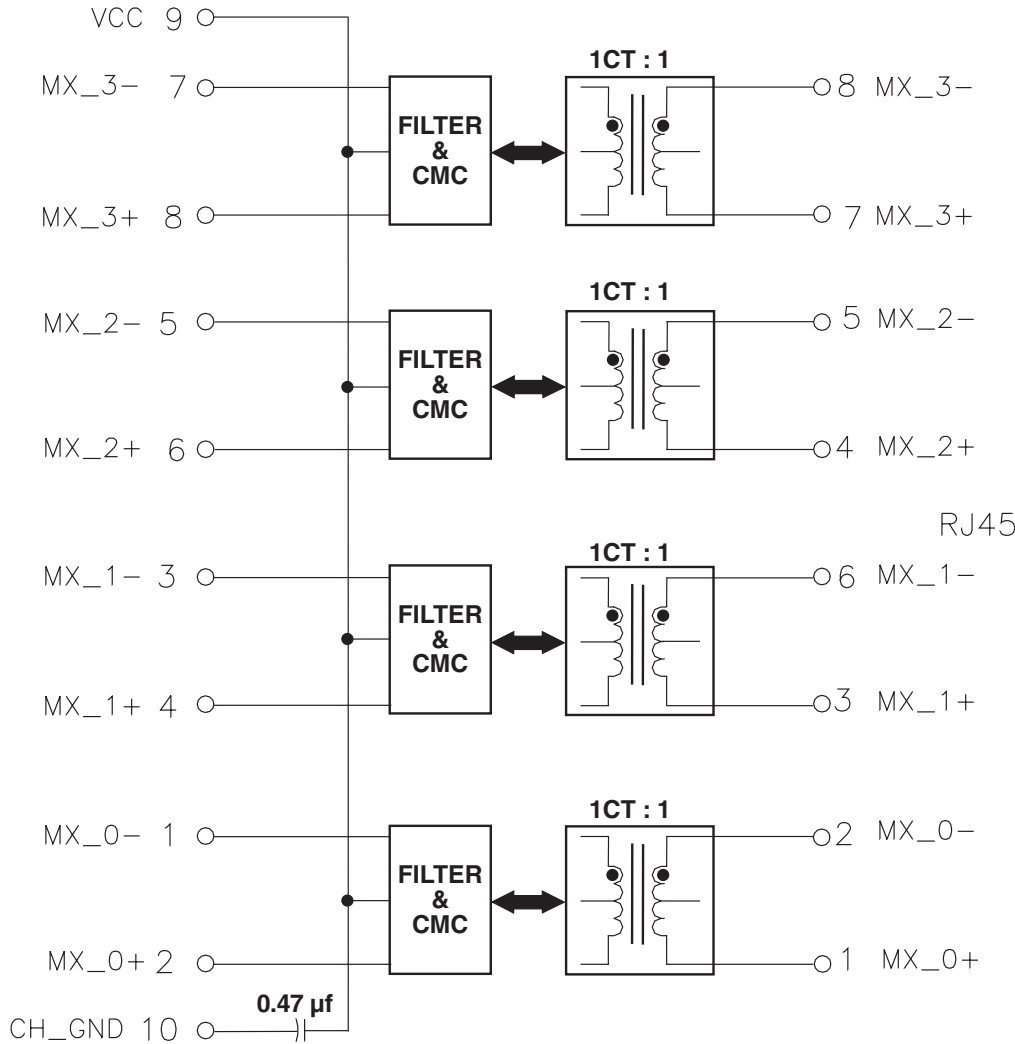

**JG0-0024**  
**JG0-0026**  
**JG0-0027**  
**JG0-0028**

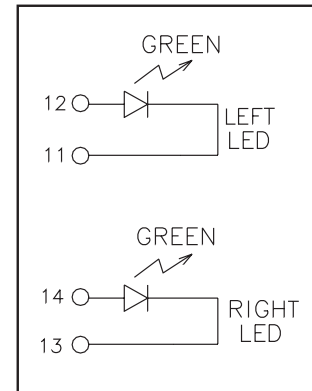

**JG0-0023**  
**JG0-0025**

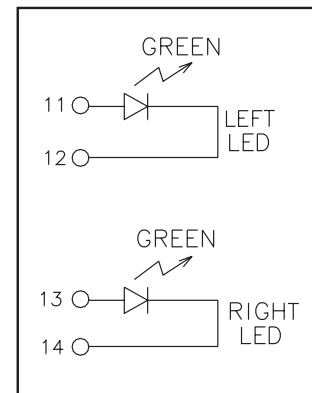

### For More Information:

UNITED STATES (Worldwide)	UNITED KINGDOM (Northern Europe)	FRANCE (Southern Europe)	SINGAPORE (Southern Asia)	TAIWAN, R.O.C. (Northern Asia)	HONG KONG (China/Hong Kong)	DISTRIBUTOR
12220 World Trade Drive San Diego, CA 92128 U.S.A. <a href="http://www.pulseeng.com">http://www.pulseeng.com</a> TEL: 858 674 8100 FAX: 858 674 8262	3 Huxley Road Surrey Research Park Guildford, Surrey GU2 5RE United Kingdom TEL: 44 1483 401700 FAX: 44 1483 401701	Zone Industrielle F-39270 Orgelet France TEL: 33 3 84 35 04 04 FAX: 33 3 84 25 46 41	150 Kampong Ampat #07-01/02 KA Centre Singapore 368324 TEL: 65 6287 8998 FAX: 65 6280 0080	3F-4, No. 81, Sec. 1 HsinTai Wu Road Hsi-Chih, Taipei Hsien Taiwan, R.O.C. Tel: 886 2 2698 0228 FAX: 886 2 2698 0948	Unit 11, 11/F Wah Lai Industrial Centre 10-14 Kwei Tei Street, Fotan, Shatin, Hong Kong TEL: 852 2788 6588 FAX: 852 2776 1055	

Performance warranty of products offered on this data sheet is limited to the parameters specified. Data is subject to change without notice. Other brand and product names mentioned herein may be trademarks or registered trademarks of their respective owners.

## Looking for pricing, stock, or lifecycle information?

Click below to explore more details on WIN SOURCE:

 [View JG0-0023 on WIN SOURCE](#)

 [Pulse Information](#)

## Optimize Your Supply Chain with WIN SOURCE Solutions

-  Global Sourcing Solution
-  Obsolete Management
-  Cost Control Management
-  Shortage Management
-  Alternative Solution
-  Excess Inventory Management