

PULSEJACK™

2XN Gigstack

Description:

10/100/1000 Base-TX RJ45 2XN Integrated Magnetics Connector without LEDs, designed to support such applications as: LAN-on-Motherboard (LOM), Hub and Switches.



Features and Benefits:

- RJ45 2XN Tab-UP 10-pin RJ45 with internal magnetics
- Options: 2X4, 2X6, and 2X8 10/100/1000 Base-TX
- Suitable for CAT 5 or 6 Fast Ethernet cable or better UTP
- Internal magnetics are 100% electrically tested for HI-POT and functionality

Electrical Performance Summary:

- Internal magnetics options available
- Meets or exceeds IEEE 802.3ab standard for 1000Base-T
- 350 μ H minimum OCL with 8 mA bias current
- High performance for maximum EMI suppression
- Minimum 1500 Vrms isolation per IEEE 802.3 requirement

Electrical Specifications @ 25°C — Operating Temperature 0°C to +70°C

| New ³ Part Number (Number of Ports) | (Replaces ³ Old Part Number) | Insertion Loss TX/RX (dB TYP) | Return Loss (dB TYP) 100 Ω ($\pm 15 \Omega$) | | | | Crosstalk (dB TYP) | | | Common Mode Rejection (dB TYP) | | Hipot (MIN) |
|---|---|--|---|-----------|------------|-------------|-----------------------|---------------|-------------|---|-----------|----------------|
| | | | 1-40 MHz | 60 MHz | 100 MHz | 1-10 MHz | 30-60 MHz | 60-100 MHz | 1-50 MHz | 50-130 MHz | | |
| JC0-0031 (2X4) | (JC065H3A) | -1.0 | -18 | -14 | -10 | -40 | -35 | -30 | -30 | -20 | 1500 Vrms | |
| JC0-0032 (2X6) | (JC065H3B) | -1.0 | -18 | -14 | -10 | -40 | -35 | -30 | -30 | -20 | 1500 Vrms | |
| JC0-0033 (2X8) | (JC065H3C) | -1.0 | -18 | -14 | -10 | -40 | -35 | -30 | -30 | -20 | 1500 Vrms | |

NOTES:

1. Both transmit and receive channels meet IEEE 802.3 specifications.
2. Different electrical and mechanical specifications can be accommodated. Contact Pulse Applications Engineering.
3. JC0-003X are replacement parts for existing products JC065H3X.

RJ45 Durability Testing Rating

| Part Number | Mating Force (MAX) | Unmating Force (MAX) | Durability | Plug to Jack Retention (MIN) |
|-------------|-----------------------|-------------------------|----------------|---------------------------------|
| JC Series | 5 lbs./2.268 kgs. | 5 lbs./2.268 kgs. | 750 Insertions | 20 lbs./9.072 kgs. |

RJ45 Material Specification

| Part Number | Shield | | Contact | | | Housing | |
|----------------|----------|--|-----------------|---|--|---------------|---------------|
| | Material | Finish | Material | Plating Area | Solder Area | Material | Specification |
| JC Series | Brass | 20-40 μ inches thick nickel over brass | Phosphor Bronze | 15 μ inches gold over 30-80 μ inches nickel | 75-300 μ inches tin-lead over 50-100 μ inches nickel | Thermoplastic | UL 94 V-0 |

Notes:

1. All connector part numbers starting with the series prefix JC comply to the above limits.
2. Connector dimensions comply with FCC dimension requirements.

Mechanicals

JC0-0031

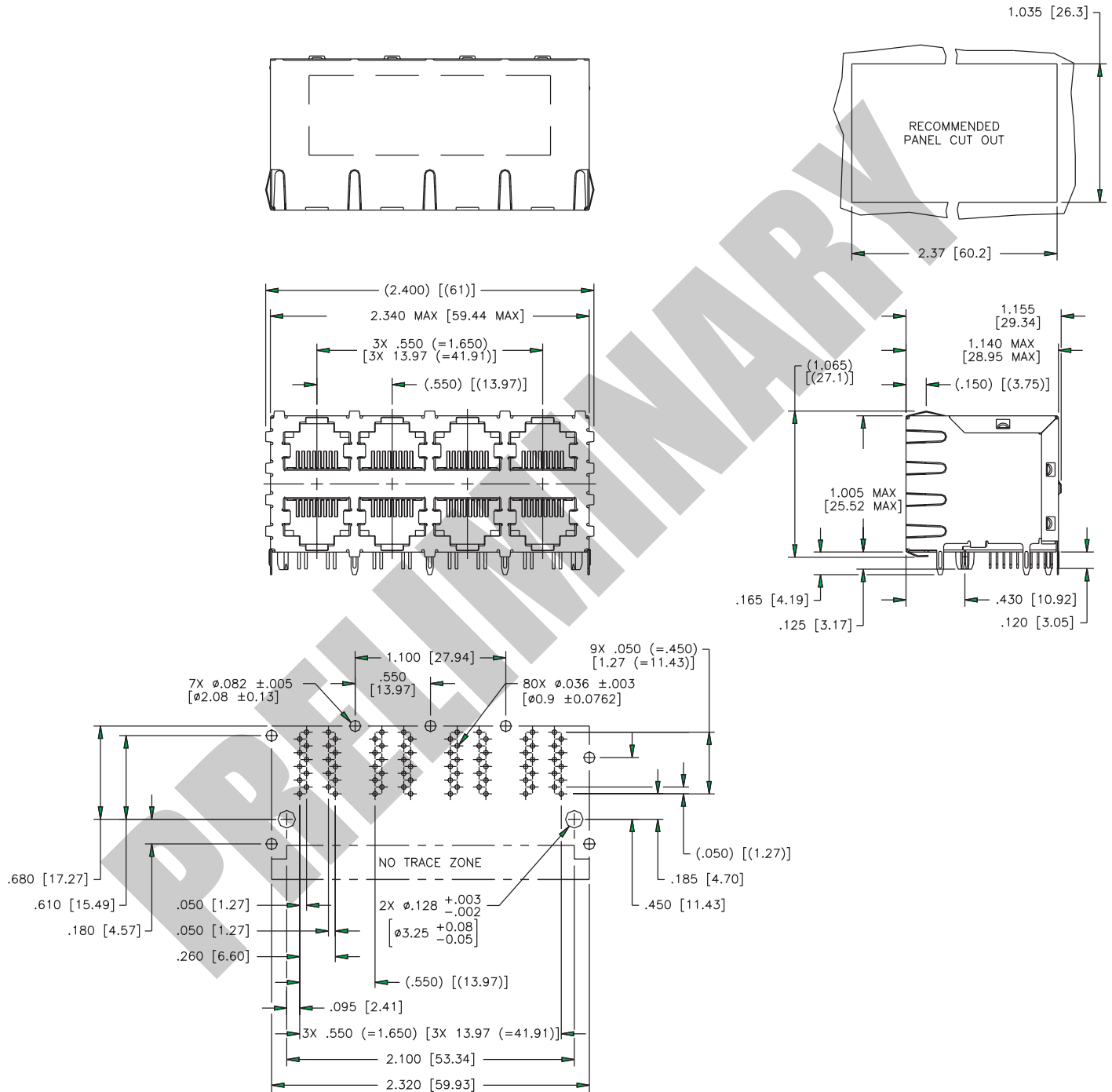

SUGGESTED PC BOARD LAYOUT VIEWED FROM COMPONENT SIDE
UNLESS OTHERWISE SPECIFIED DIMENSIONAL TOLERANCE IS $\pm .002$



Mechanicals

JC0-0032

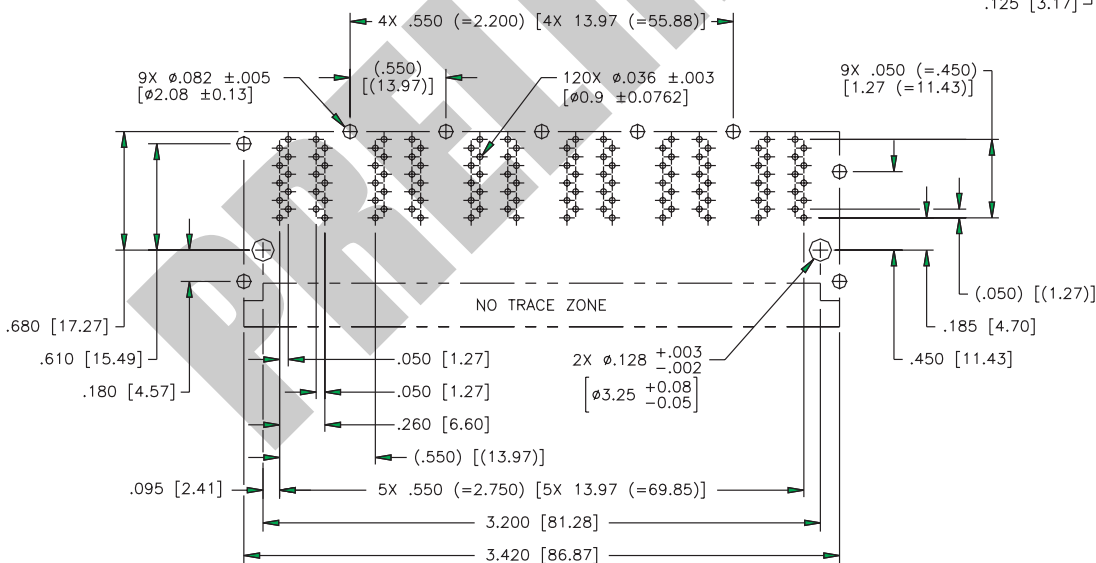
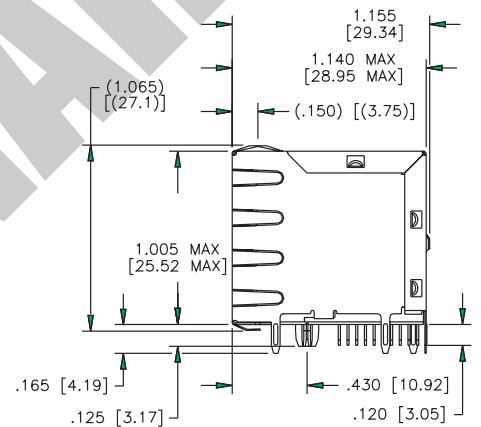
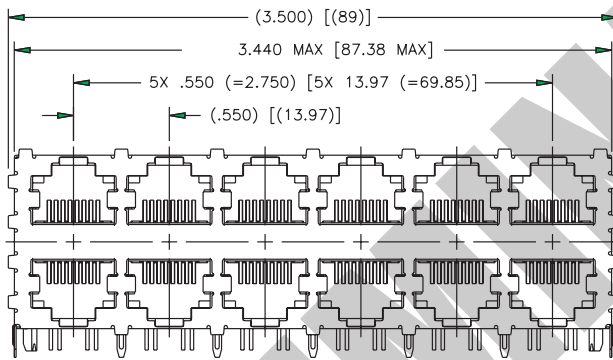
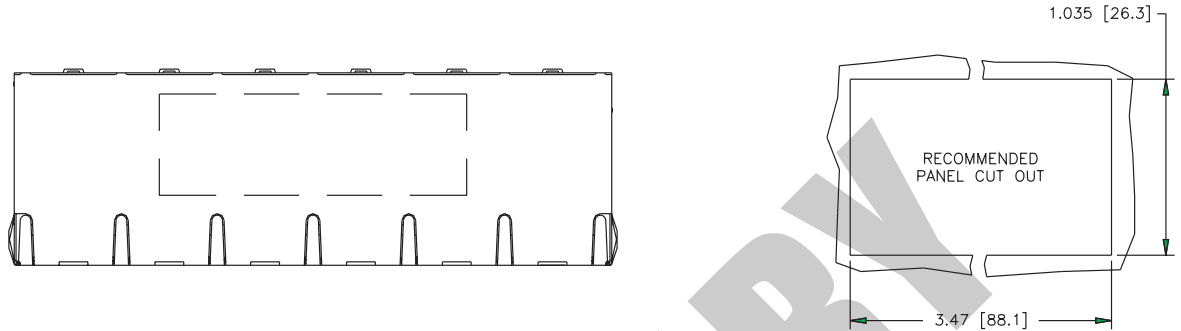

SUGGESTED PC BOARD LAYOUT VIEWED FROM COMPONENT SIDE
 UNLESS OTHERWISE SPECIFIED DIMENSIONAL TOLERANCE IS ±.002

Mechanicals

JC0-0033

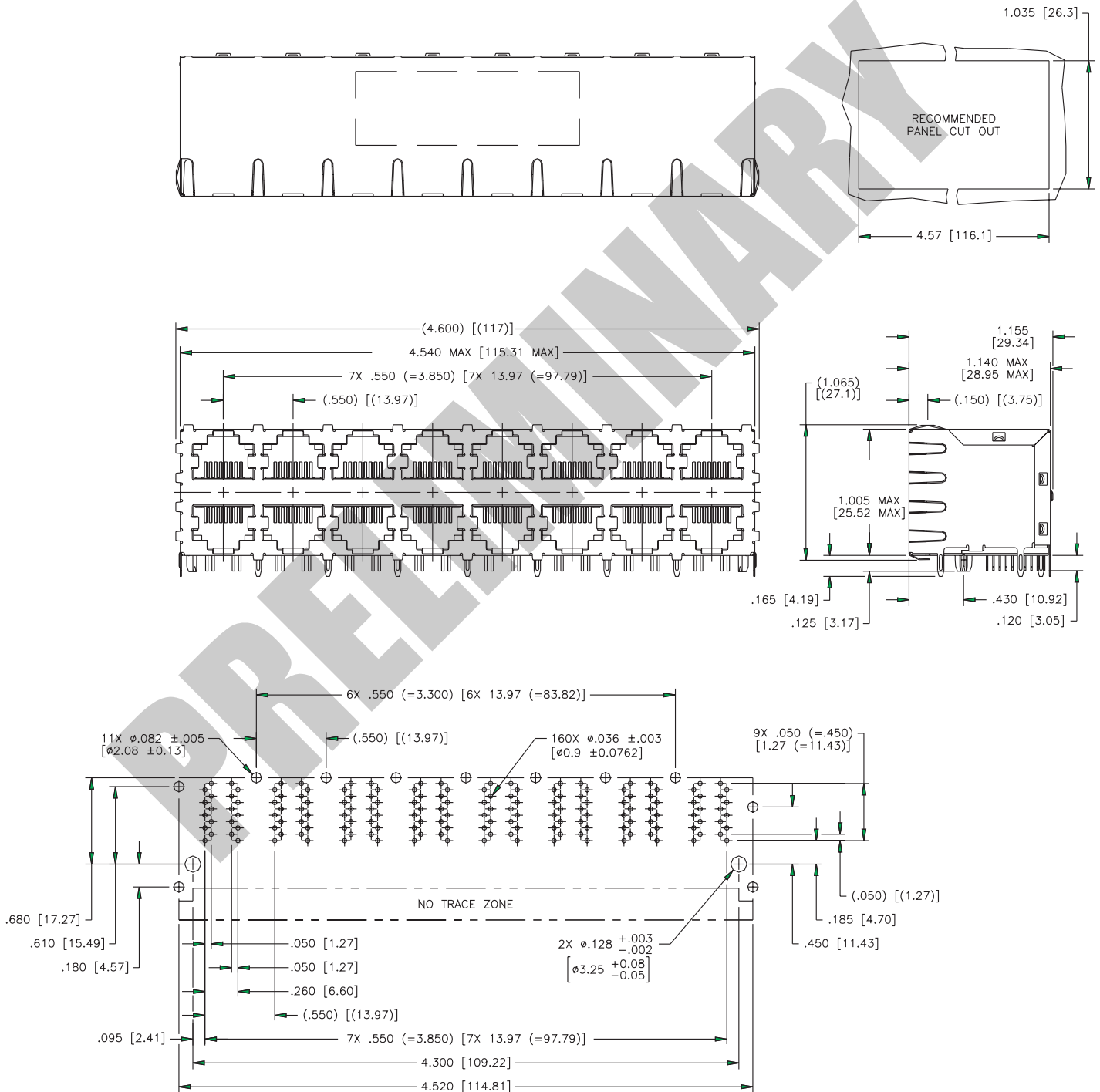

Mechanicals

JC0-0031/32/33

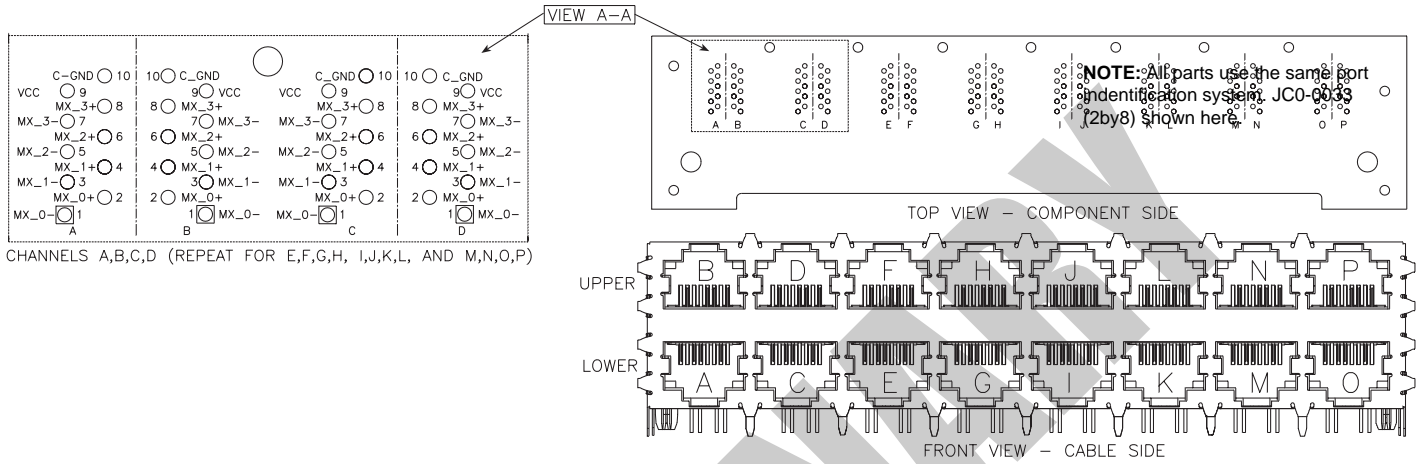

Schematic

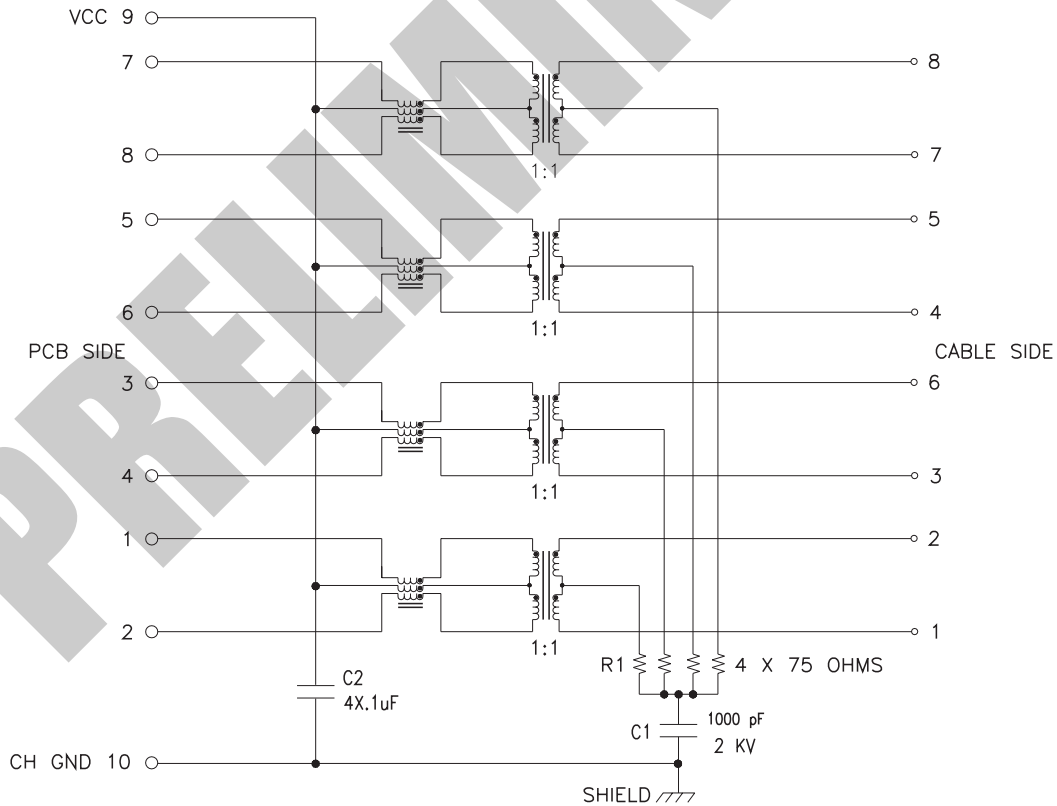

For More Information :

| UNITED STATES (Worldwide) | UNITED KINGDOM (Northern Europe) | FRANCE (Southern Europe) | SINGAPORE (Southern Asia) | TAIWAN, R.O.C. (Northern Asia) | HONG KONG (China/Hong Kong) | DISTRIBUTOR |
|---|--|---|---|---|---|-------------|
| 12220 World Trade Drive San Diego, CA 92128 U.S.A. http://www.pulseeng.com TEL: 858 674 8100 FAX: 858 674 8262 | 1 & 2 Huxley Road The Surrey Research Park Guildford, Surrey GU2 5RE United Kingdom TEL: 44 1483 401700 FAX: 44 1483 401701 | Zone Industrielle F-39270 Orgelet France TEL: 33 3 84 35 04 04 FAX: 33 3 84 25 46 41 | 150 Kampong Ampat #07-01/02 KA Centre Singapore 368324 TEL: 65 6287 8998 FAX: 65 6280 0080 | 3F-4, No. 81, Sec. 1 HsinTai Wu Road Hsi-Chih, Taipei Hsien Taiwan, R.O.C. Tel: 886 2 2698 0228 FAX: 886 2 2698 0948 | 9/F, Phase 2, Tai Sang Shatin Warehouse Centre 6 Wong Chuk Yeung Street Fotan, Shatin, Hong Kong TEL: 852 2788 6588 FAX: 852 2776 1055 | |

This is a "Preliminary" product data sheet. Products mentioned on this data sheet are in development and in the process of being qualified. These products are not fully released nor are they in production. Features, specifications and performance of products offered are subject to change without notice. Other brand and product names mentioned herein may be products and/or registered trademarks of their respective owners. For current information on this product, please contact the Pulse office nearest you and ask for the "LAN Applications Engineer."

Looking for pricing, stock, or lifecycle information?

Click below to explore more details on WIN SOURCE:

 [View JC0-0032 on WIN SOURCE](#)

 [Pulse Information](#)

Optimize Your Supply Chain with WIN SOURCE Solutions

-  Global Sourcing Solution
-  Obsolete Management
-  Cost Control Management
-  Shortage Management
-  Alternative Solution
-  Excess Inventory Management