

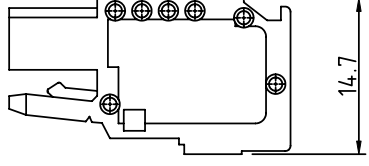

**THE DATASHEET OF
HI13005000J0G**

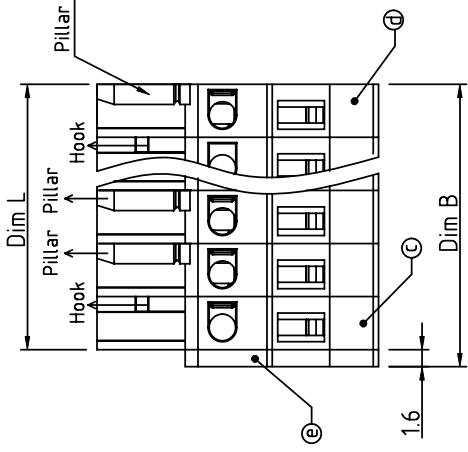

PRODUCT NUMBER	PITCH
Hlxx00x000 J0G	5.00 mm

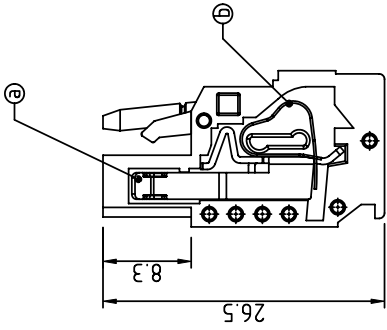
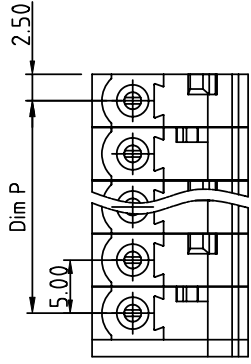

Layout of Hook and Pillar

2P	Hook+Pillar
3P	Hook+Hook+Pillar
4P	Hook+Pillar+Hook+Pillar
5P	Hook+Pillar+Pillar+Hook+Pillar
5P over	Hook+Pillar+...+Pillar+Hook+Pillar

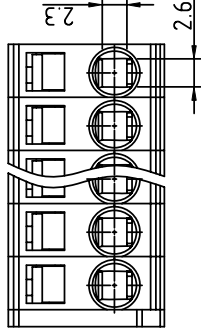

PART NO.: HI XX 00 X 0 00J0 G

Poles	Tolerance
2P	±0.10
3P-6P	±0.15
7P-12P	±0.20
13P-18P	±0.30
19P-24P	±0.40

DIMENSION	
Dim L=Nx5.0	
Dim P=(N-1)x5.0	
Dim B=Nx5.0+1.6	

N=Number of poles

- End stackable 0 Black (RAL9005)
 - No. of poles 2 Red (RAL3001/D)
 - 02 2 poles 3 Orange(RAL2011/P)
 - 03 3 poles 4 Yellow(RAL1018/A)
 - ... 5 Green(RAL6018/T)
 - 24 24 poles 6 Blue (RAL5015/A)
 - 8 Grey(RAL7035/D)
 - 9 White(RAL1102)
 - C Green(RAL6018/U)
- Color
- RoHS compliant (lead<4%) in copper Alloy

- Material
- Item Ⓐ
 - Item Ⓑ
 - Item Ⓒ
 - Item Ⓓ
 - Item Ⓔ
- Electric
- Voltage
 - Current
- Wire
- Wire ra
 - Solid w
 - Strand
 - Wire st
 - Withst
 - Operat
 - Safety

mat'l. code		it		surface	
ltr	ecn no	dr	date	ASME	Y14.5
				tolerances	unless
				angles	off
				X	
				X±1°	
				dr	EVIN ZHON
				enfr	EVIN ZHON
				chr	HANKE FEI
				appd	SHI JUN
sheet	revision	A			
index	sheet	1			

form: A4mmXlc





Looking for pricing, stock, or lifecycle information?

Click below to explore more details on WIN SOURCE:

 [View HI13005000J0G on WIN SOURCE](#)

 [Amphenol FCI Information](#)

Optimize Your Supply Chain with WIN SOURCE Solutions

-  Global Sourcing Solution
-  Obsolete Management
-  Cost Control Management
-  Shortage Management
-  Alternative Solution
-  Excess Inventory Management