



# HFBR-5961LZ/ALZ/GZ/AGZ

Multimode Small Form Factor (SFF) Transceivers for ATM, FDDI, Fast Ethernet and SONET OC-3/SDH STM-1 with LC connector



## Data Sheet



### Description

The HFBR-5961xxZ transceiver from Avago provides the system designer with a product to implement a range of solutions for multimode fiber Fast Ethernet and SONET OC-3 (SDH STM-1) physical layers for ATM and other services.

This transceiver is supplied in the industry standard 2 x 5 DIP style with an LC fiber connector interface with an external connector shield.

### Transmitter Section

The transmitter section of the HFBR-5961xxZ utilizes a 1300 nm InGaAsP LED. This LED is packaged in the optical subassembly portion of the transmitter section. It is driven by a custom silicon IC which converts differential PECL logic signals, ECL referenced (shifted) to a +3.3 V supply, into an analog LED drive current.

### Receiver Section

The receiver section of the HFBR-5961xxZ utilizes an InGaAs PIN photodiode coupled to a custom silicon transimpedance preamplifier IC. It is packaged in the optical subassembly portion of the receiver.

This PIN/preamplifier combination is coupled to a custom quantizer IC which provides the final pulse shaping for the logic output and the Signal Detect function. The Data output is differential. The Signal Detect output is single ended. Both Data and Signal Detect outputs are PECL compatible, ECL referenced (shifted) to a +3.3 V power supply. The receiver outputs, Data Output and Data Out Bar, are squelched at Signal Detect deassert. That is, when the light input power decreases to a typical -38 dBm or less, the Signal Detect deasserts, ie. the Signal Detect output goes to a PECL low state. This forces the receiver outputs, Data Out and Data Out Bar to go steady PECL levels high and low respectively.

### Features

- Multisourced 2 x 5 package style
- Operates with 62.5/125  $\mu\text{m}$  and 50/125  $\mu\text{m}$  multimode fiber
- Single +3.3 V power supply
- Wave solder and aqueous wash process compatibility
- Manufactured in an ISO 9001 certified facility
- Full compliance with ATM Forum
- UNI SONET OC-3 multimode fiber physical layer specification
- Full compliance with the optical performance requirements of the FDDI PMD standard
- Full compliance with the optical performance requirements of 100Base-FX version of IEEE802.3u
- RoHS compliant
- PECL Signal Detect Output
- Temperature range:

HFBR-5961LZ	0 °C to +70 °C
HFBR-5961ALZ	-40 °C to +85 °C
HFBR-5961GZ	0 °C to +70°C (No EMI shield)
HFBR-5961AGZ	-40 °C to +85°C (No EMI shield)

### Applications

- SONET/SDH equipment interconnect, OC-3/SDH STM-1 rate
- Fast Ethernet
- Multimode fiber ATM backbone links

## Package

The overall package concept for the Avago transceiver consists of three basic elements; the two optical subassemblies, an electrical subassembly, and the housing as illustrated in the block diagram in Figure 1.

The package outline drawing and pin out are shown in Figures 2 and 5. The details of this package outline and pin out are compliant with the multisource definition of the 2 x 5 DIP. The low profile of the Avago transceiver design complies with the maximum height allowed for the LC connector over the entire length of the package.

The optical subassemblies utilize a high-volume assembly process together with low-cost lens elements which result in a cost effective building block.

The electrical subassembly consists of a high volume multilayer printed circuit board on which the ICs and various surface mounted passive circuit elements are attached.

The receiver section includes an internal shield for the electrical and optical subassemblies to ensure high immunity to external EMI fields.

The outer housing including the LC ports is molded of filled nonconductive plastic to provide mechanical strength. The solder posts of the Avago design are isolated from the internal circuit of the transceiver.

The transceiver is attached to a printed circuit board with the ten signal pins and the two solder posts which exit the bottom of the housing. The two solder posts provide the primary mechanical strength to withstand the loads imposed on the transceiver by mating with the LC connector fiber cables.

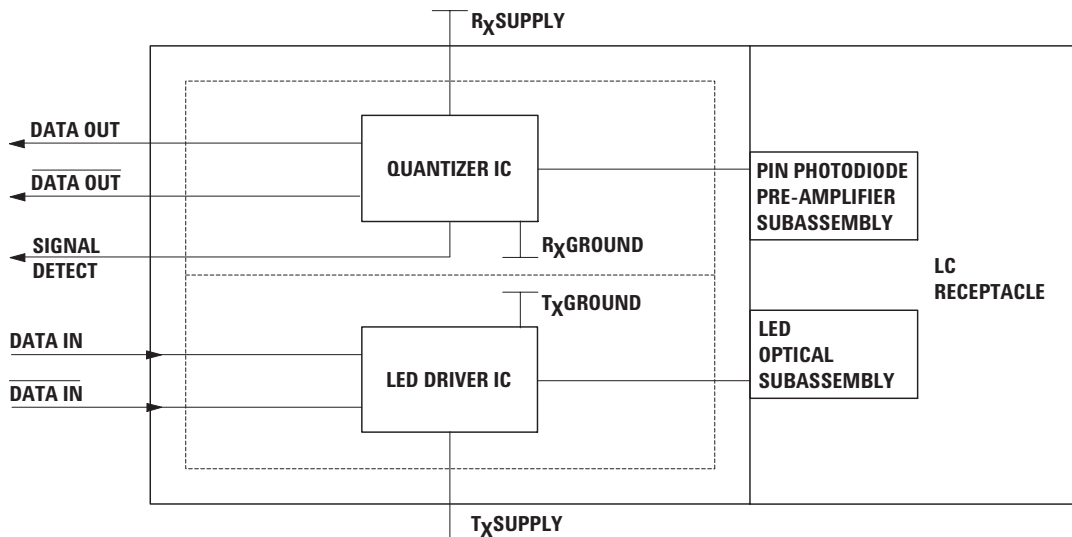

Figure 1. Block Diagram

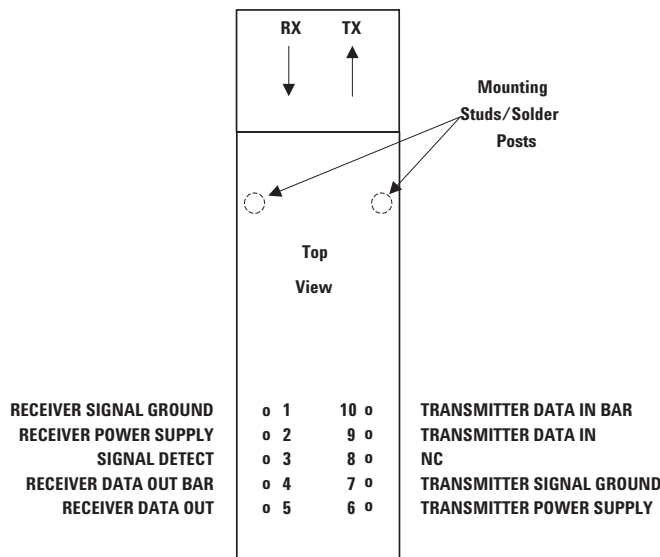

Figure 2. Pin Out Diagram

### Pin Descriptions:

#### Pin 1 Receiver Signal Ground $V_{EE}$ RX:

Directly connect this pin to the receiver ground plane.

#### Pin 2 Receiver Power Supply $V_{CC}$ RX:

Provide +3.3 V dc via the recommended receiver power supply filter circuit. Locate the power supply filter circuit as close as possible to the  $V_{CC}$  RX pin.

#### Pin 3 Signal Detect SD:

Normal optical input levels to the receiver result in a logic "1" output.

Low optical input levels to the receiver result in a logic "0" output.

This Signal Detect output can be used to drive a PECL input on an upstream circuit, such as Signal Detect input of Loss of Signal-Bar.

#### Pin 4 Receiver Data Out Bar RD-:

No internal terminations are provided. See recommended circuit schematic.

#### Pin 5 Receiver Data Out RD+:

No internal terminations are provided. See recommended circuit schematic.

#### Pin 6 Transmitter Power Supply $V_{CC}$ TX:

Provide +3.3 V dc via the recommended transmitter power supply filter circuit. Locate the power supply filter circuit as close as possible to the  $V_{CC}$  TX pin.

#### Pin 7 Transmitter Signal Ground $V_{EE}$ TX:

Directly connect this pin to the transmitter ground plane.

#### Pin 8 NC:

No connection.

#### Pin 9 Transmitter Data In TD+:

No internal terminations are provided. See recommended circuit schematic.

#### Pin 10 Transmitter Data In Bar TD-:

No internal terminations are provided. See recommended circuit schematic.

### Mounting Studs/Solder Posts

The mounting studs are provided for transceiver mechanical attachment to the circuit board. It is recommended that the holes in the circuit board be connected to chassis ground.

### Application Information

The Applications Engineering group is available to assist you with the technical understanding and design trade-offs associated with these transceivers. You can contact them through your Avago sales representative.

The following information is provided to answer some of the most common questions about the use of these parts.

#### Transceiver Optical Power Budget versus Link Length

Optical Power Budget (OPB) is the available optical power for a fiber optic link to accommodate fiber cable losses plus losses due to in-line connectors, splices, optical switches, and to provide margin for link aging and unplanned losses due to cable plant reconfiguration or repair.

Avago LED technology has produced 1300 nm LED devices with lower aging characteristics than normally associated with these technologies in the industry. The industry convention is 1.5 dB aging for 1300 nm LEDs. The 1300 nm Avago LEDs are specified to experience less than 1 dB of aging over normal commercial equipment mission life periods. Contact your Avago sales representative for additional details.

## Recommended Handling Precautions

Avago recommends that normal status precautions be taken in the handling and assembly of these transceivers to prevent damage which may be induced by electrostatic discharge (ESD). The HFBR-5961xxZ series of transceivers meet MIL-STD-883C Method 3015.4 Class 2 products.

Care should be used to avoid shorting the receiver data or signal detect outputs directly to ground without proper current limiting impedance.

## Solder and Wash Process Compatibility

The transceivers are delivered with protective process plugs inserted into the LC receptacle.

This process plug protects the optical subassemblies during wave solder and aqueous wash processing and acts as a dust cover during shipping.

These transceivers are compatible with either industry standard wave or hand solder processes.

## Shipping Container

The transceiver is packaged in a shipping container designed to protect it from mechanical and ESD damage during shipment of storage.

## Board Layout - Decoupling Circuit, Ground Planes and Termination Circuits

It is important to take care in the layout of your circuit board to achieve optimum performance from these transceivers. Figure 3 provides a good example of a schematic for a power supply decoupling circuit that works well with these parts. It is further recommended that a contiguous ground plane be provided in the circuit board directly under the transceiver to provide a low inductance ground for signal return current. This recommendation is in keeping with good high frequency board layout practices. Figures 3 and 4 show two recommended termination schemes.

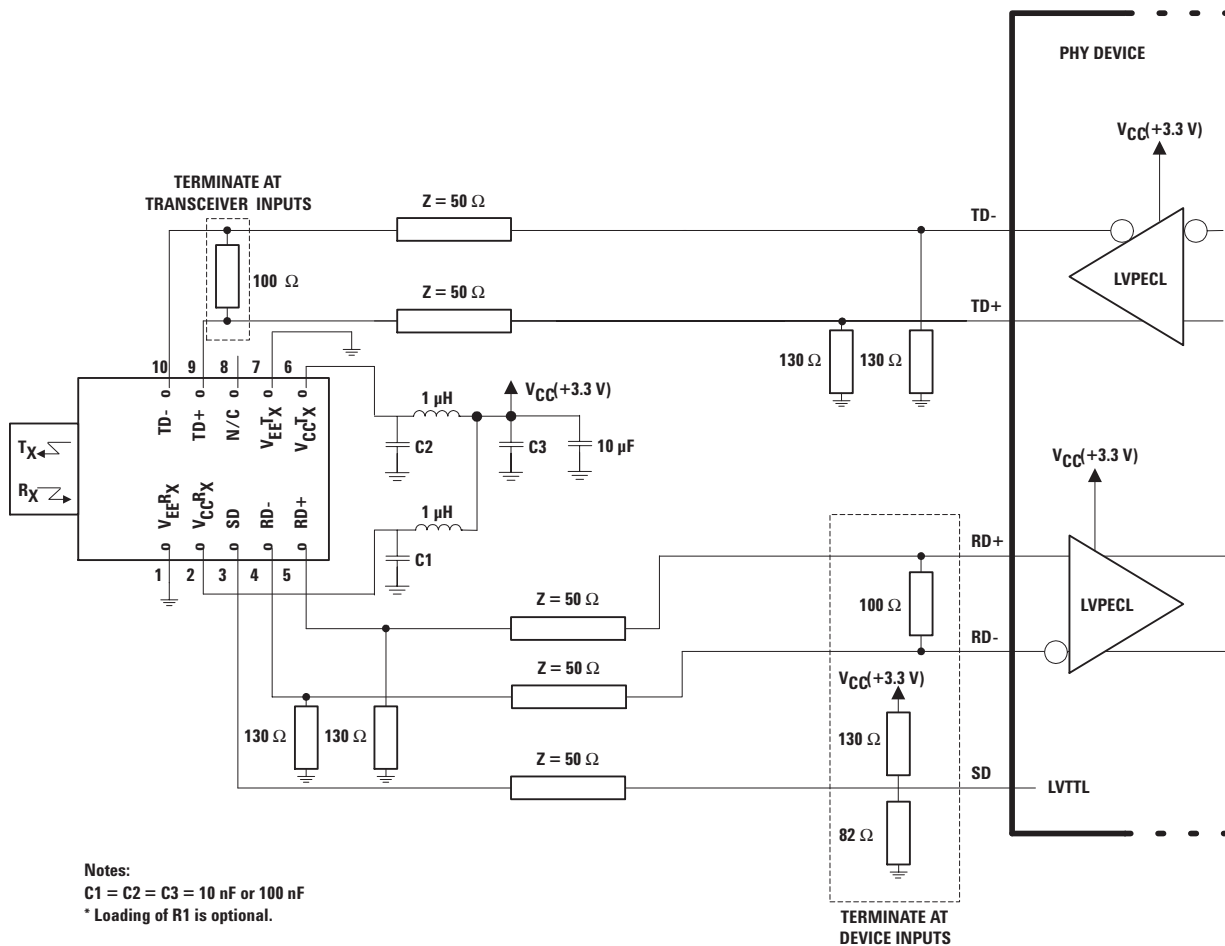

Figure 3. Recommended Decoupling and Termination Circuits

## Board Layout - Hole Pattern

The Avago transceiver complies with the circuit board "Common Transceiver Footprint" hole pattern defined in the original multisource announcement which defined the 2 x 5 package style. This drawing is reproduced in Figure 6 with the addition of ANSI Y14.5M compliant dimensioning to be used as a guide in the mechanical layout of your circuit board. Figure 6 illustrates the recommended panel opening and the position of the circuit board with respect to this panel.

## Regulatory Compliance

These transceiver products are intended to enable commercial system designers to develop equipment that complies with the various international regulations governing certification of Information Technology Equipment. See the Regulatory Compliance Table for details. Additional information is available from your Avago sales representative.

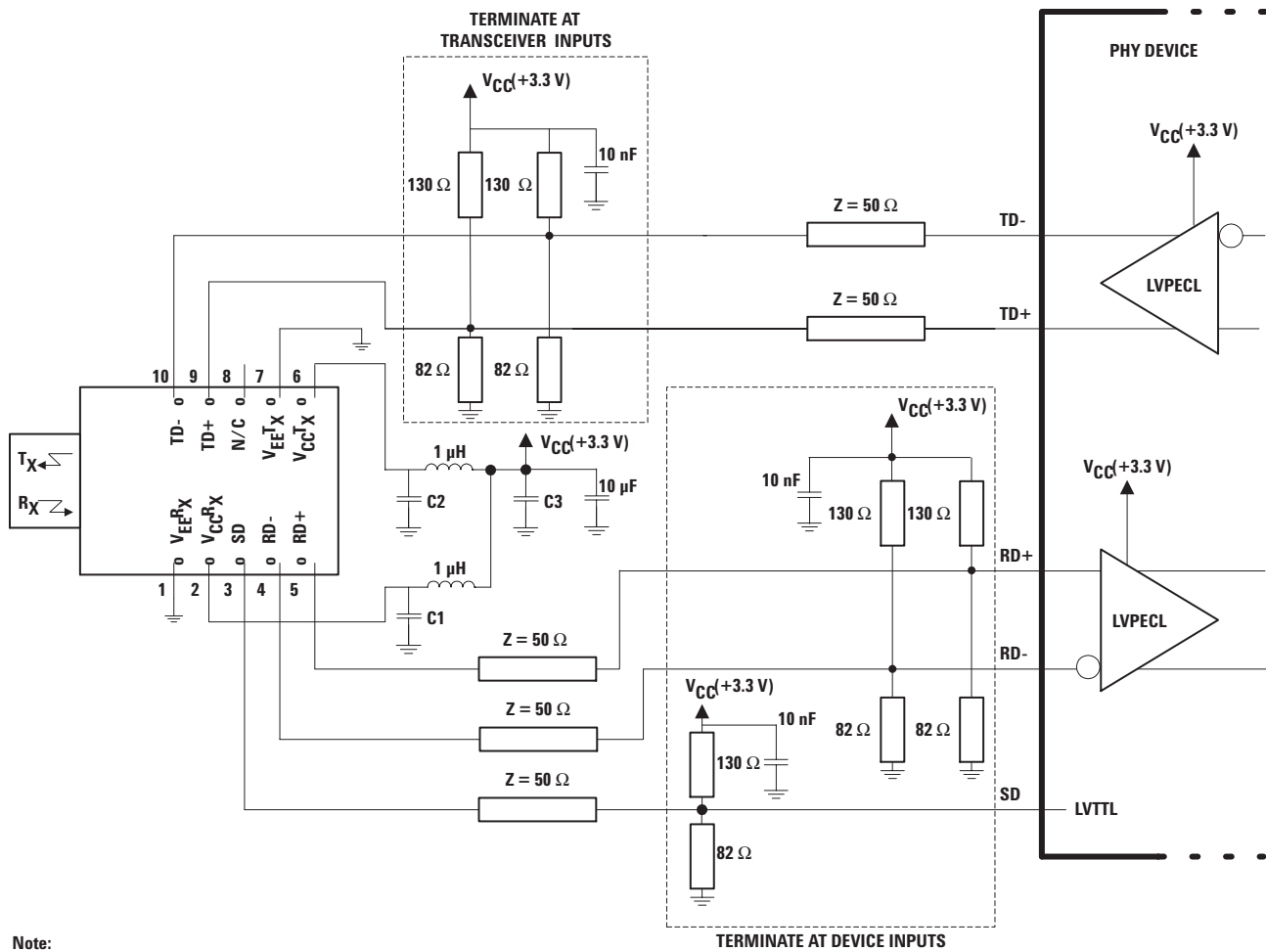

Note:  
 C1 = C2 = C3 = 10 nF or 100 nF  
 \* Loading R1 is optional.

Figure 4. Alternative Termination Circuits

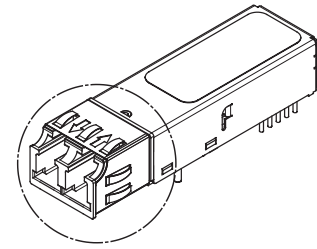
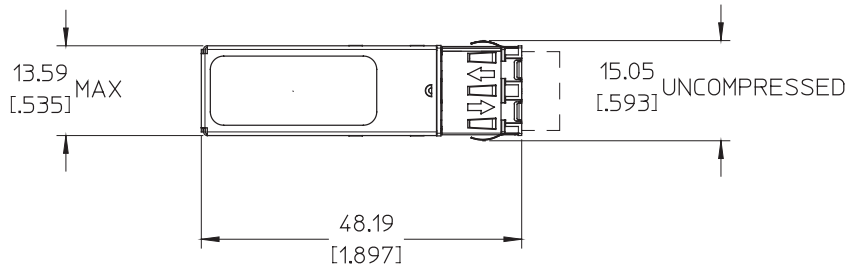

SEE DETAIL 1

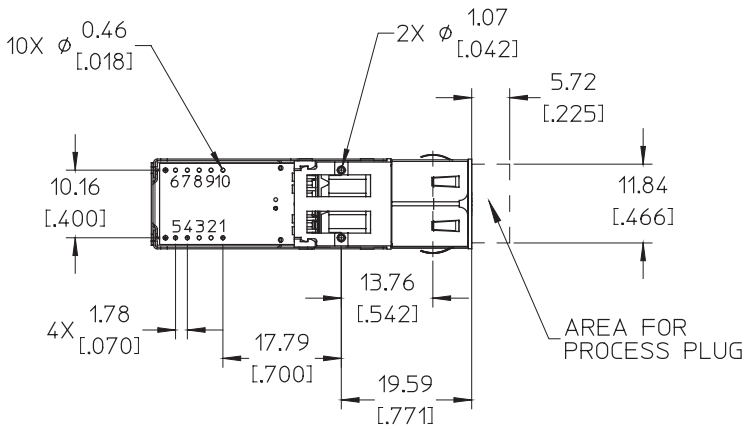
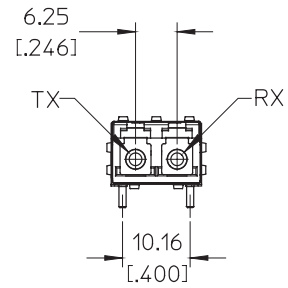
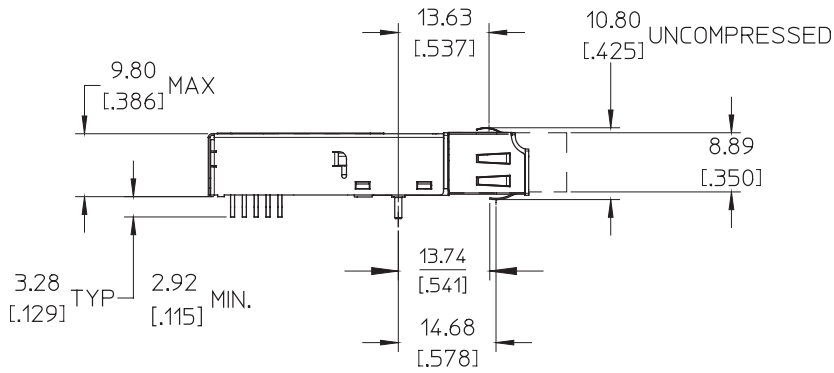

Tcase REFERENCE POINT

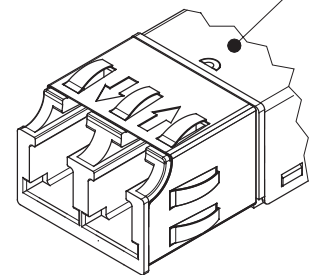

DETAIL 1  
Scale 3X

ALL DIMENSIONS IN MILLIMETERS(INCHES)

Figure 5. Package Outline Drawing

## Electrostatic Discharge (ESD)

There are two design cases in which immunity to ESD damage is important.

The first case is during handling of the transceiver prior to mounting it on the circuit board. It is important to use normal ESD handling precautions for ESD sensitive devices. These precautions include using grounded wrist straps, work benches, and floor mats in ESD controlled areas.

The second case to consider is static discharges to the exterior the equipment chassis containing the transceiver parts. To the extent that the LC connector is exposed to the outside of the equipment chassis it may be subject to whatever ESD system level test criteria that the equipment is intended to meet.

## Electromagnetic Interference (EMI)

Most equipment designs utilizing this high speed transceiver from Avago will be required to meet the requirements of FCC in the United States, CENELEC EN55022 (CISPR 22) in Europe and VCCI in Japan.

This product is suitable for use in designs ranging from a desktop computer with a single transceiver to a concentrator or switch product with a large number of transceivers.

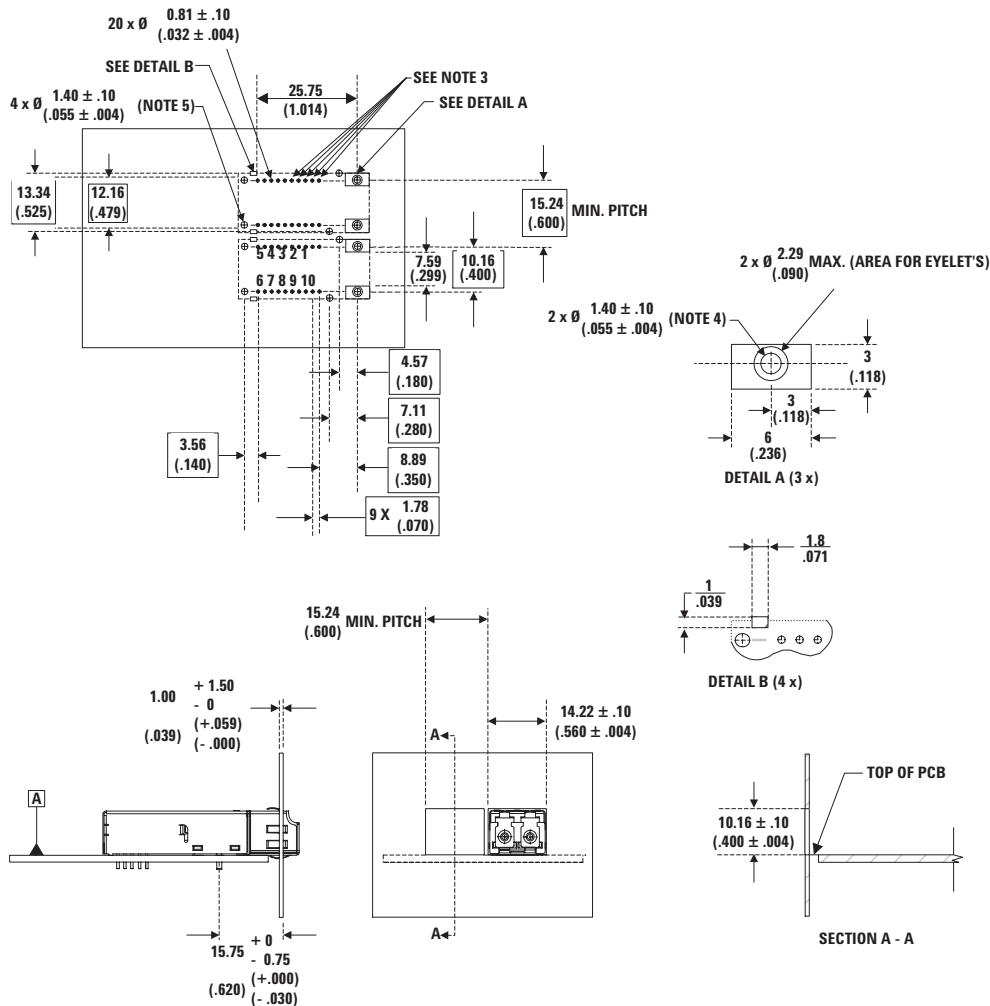

### NOTES:

1. THIS PAGE DESCRIBES THE RECOMMENDED CIRCUIT BOARD LAYOUT AND FRONT PANEL OPENINGS FOR SFF TRANSCEIVERS.
2. THE HATCHED AREAS ARE KEEP-OUT AREAS RESERVED FOR HOUSING STANDOFFS. NO METAL TRACES ALLOWED IN KEEP-OUT AREAS.
3. THIS DRAWING SHOWS EXTRA PIN HOLES FOR 2 x 6 PIN AND 2 x 10 PIN TRANSCEIVERS. THESE EXTRA HOLES ARE NOT REQUIRED FOR HFBR-5961xxZ AND OTHER 2 x 5 PIN SFF MODULES.
4. HOLES FOR MOUNTING STUDS MUST NOT BE TIED TO SIGNAL GROUND BUT MAY BE TIED TO CHASSIS GROUND.
5. HOLES FOR HOUSING LEADS OPTIONAL AND NOT REQUIRED FOR HFBR-5961L/HFBR-5961G. IF NEEDED IN FUTURE, THESE HOLES MUST BE TIED TO SIGNAL GROUND.
6. ALL DIMENSIONS ARE IN MILLIMETERS (INCHES).

**Figure 6. Recommended Board Layout Hole Pattern**

## Immunity

Equipment utilizing these transceivers will be subject to radio-frequency electromagnetic fields in some environments. These transceivers have a high immunity to such fields.

For additional information regarding EMI, susceptibility, ESD and conducted noise testing procedures and results. Refer to Application Note 1166, Minimizing Radiated Emissions of High-Speed Data Communications Systems.

## Transceiver Reliability and Performance Qualification Data

The 2 x 5 transceivers have passed Avago reliability and performance qualification testing and are undergoing ongoing quality and reliability monitoring. Details are available from your Avago sales representative.

These transceivers are manufactured at the Avago Singapore location which is an ISO 9001 certified facility.

## Applications Support Material

Contact your local Avago Component Field Sales Office for information on how to obtain PCB layouts and evaluation boards for the 2 x 5 transceivers.

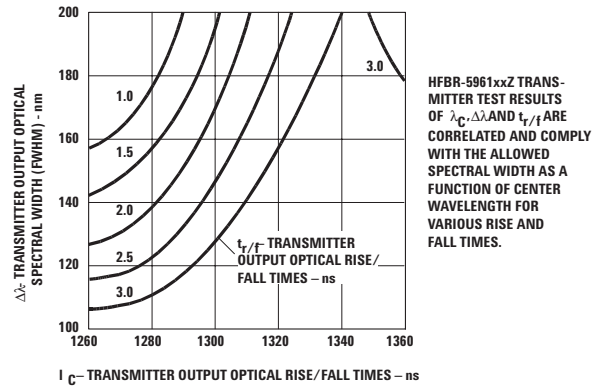

Figure 7. Transmitter Output Optical Spectral Width (FWHM) vs. Transmitter Output Optical Center Wavelength and Rise/Fall Times

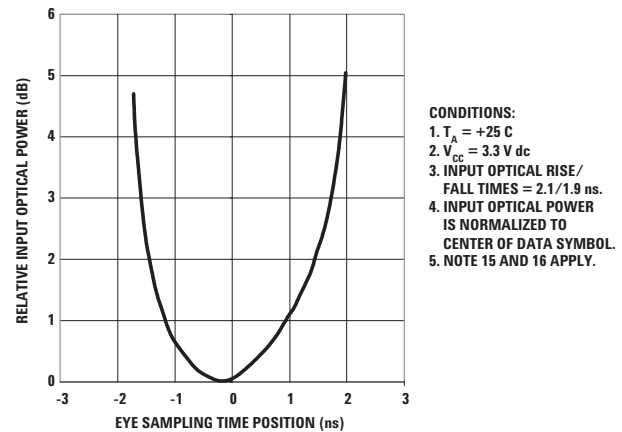

Figure 8. Relative Input Optical Power vs Eye Sampling Time Position

## Regulatory Compliance Table

Feature	Test Method	Performance
Electrostatic Discharge (ESD) to the Electrical Pins	MIL-STD-883C	Meets Class 2 (2000 to 3999 Volts). Withstand up to 2200 V applied between electrical pins.
Electrostatic Discharge (ESD) to the LC Receptacle	Variation of IEC 61000-4-2	Typically withstand at least 25 kV without damage when the LC connector receptacle is contacted by a Human Body Model probe.
Electromagnetic Interference (EMI)	FCC Class B CENELEC CEN55022 VCCI Class 2	Transceivers typically provide a 10 dB margin to the noted standard limits when tested at a certified test range with the transceiver mounted to a circuit card without a chassis enclosure.
Immunity	Variation of IEC 61000-4-3	Typically show no measurable effect from a 10 V/m field swept from 80 to 450 MHz applied to the transceiver when mounted to a circuit card without a chassis enclosure.
Eye Safety	AEL Class 1 EN60825-1 (+A11)	Compliant per Avago testing under single fault conditions. TUV Certification - R 02071015
Component Recognition	Underwriters Laboratories and Canadian Standards Association Joint Component Recognition for Information Technology Equipment including Electrical Business Equipment	UL File #: E173874

## Absolute Maximum Ratings

Stresses in excess of the absolute maximum ratings can cause catastrophic damage to the device. Limits apply to each parameter in isolation, all other parameters having values within the recommended operating conditions. It should not be assumed that limiting values of more than one parameter can be applied to the product at the same time. Exposure to the absolute maximum ratings for extended periods can adversely affect device reliability.

Parameter	Symbol	Minimum	Typical	Maximum	Units	Notes
Storage Temperature	T <sub>S</sub>	-40		+100	°C	
Lead Soldering Temperature	T <sub>SOLD</sub>			+260	°C	
Lead Soldering Time	t <sub>SOLD</sub>			10	sec	
Supply Voltage	V <sub>CC</sub>	-0.5		3.63	V	
Data Input Voltage	V <sub>I</sub>	-0.5		V <sub>CC</sub>	V	
Differential Input Voltage (p-p)	V <sub>D</sub>			2.0	V	1
Output Current	I <sub>O</sub>			50	mA	

## Recommended Operating Conditions

Parameter	Symbol	Minimum	Typical	Maximum	Units	Notes
Case Operating Temperature						
HFBR-5961LZ/GZ	T <sub>C</sub>	0		+70	°C	
HFBR-5961ALZ/AGZ	T <sub>C</sub>	-40		+85	°C	
Supply Voltage	V <sub>CC</sub>	2.97	3.3	3.63	V	
Data Input Voltage - Low	V <sub>IL</sub> - V <sub>CC</sub>	-1.810		-1.475	V	
Data Input Voltage - High	V <sub>IH</sub> - V <sub>CC</sub>	-1.165		-0.880	V	
Data and Signal Detect Output Load	R <sub>L</sub>		50		Ω	2
Differential Input Voltage (p-p)	V <sub>D</sub>		0.800		V	

## Transmitter Electrical Characteristics

HFBR-5961LZ/GZ (T<sub>C</sub> = 0 °C to +70 °C, V<sub>CC</sub>=2.97 V to 3.63 V)

HFBR-5961ALZ/AGZ (T<sub>C</sub> = -40 °C to +85 °C, V<sub>CC</sub>=2.97 V to 3.63V)

Parameter	Symbol	Minimum	Typical	Maximum	Units	Notes
Supply Current	I <sub>CC</sub>		110	175	mA	3
Power Dissipation	P <sub>DISS</sub>		0.4	0.64	W	5a
Data Input Current - Low	I <sub>IL</sub>	-350	-2		μA	
Data Input Current - High	I <sub>IH</sub>		18	350	μA	

## Receiver Electrical Characteristics

HFBR-5961LZ/AGZ ( $T_C = 0\text{ }^\circ\text{C}$  to  $+70\text{ }^\circ\text{C}$ ,  $V_{CC} = 2.97\text{V}$  to  $3.63\text{V}$ )

HFBR-5961ALZ/AGZ ( $T_C = -40\text{ }^\circ\text{C}$  to  $+85\text{ }^\circ\text{C}$ ,  $V_{CC} = 2.97\text{V}$  to  $3.63\text{V}$ )

Parameter	Symbol	Minimum	Typical	Maximum	Units	Notes
Supply Current	$I_{CC}$		65	120	mA	4
Power Dissipation	$P_{DISS}$		0.225	0.44	W	5b
Data Output Voltage - Low	$V_{OL} - V_{CC}$	-1.840		-1.620	V	6
Data Output Voltage - High	$V_{OH} - V_{CC}$	-1.045		-0.880	V	6
Data Output Rise Time	$t_r$	0.35		2.2	ns	7
Data Output Fall Time	$t_f$	0.35		2.2	ns	7
Signal Detect Output Voltage - Low	$V_{OL} - V_{CC}$	-1.840		-1.620	V	6
Signal Detect Output Voltage - High	$V_{OH} - V_{CC}$	-1.045		-0.880	V	6
Signal Detect Output Rise Time	$t_r$	0.35		2.2	ns	7
Signal Detect Output Fall Time	$t_f$	0.35		2.2	ns	7
Power Supply Noise Rejection	PSNR		50		mV	

## Transmitter Optical Characteristics

HFBR-5961LZ/GZ ( $T_C = 0\text{ }^\circ\text{C}$  to  $+70\text{ }^\circ\text{C}$ ,  $V_{CC} = 2.97\text{V}$  to  $3.63\text{V}$ )

HFBR-5961ALZ/AGZ ( $T_C = -40\text{ }^\circ\text{C}$  to  $+85\text{ }^\circ\text{C}$ ,  $V_{CC} = 2.97\text{V}$  to  $3.63\text{V}$ )

Parameter	Symbol	Minimum	Typical	Maximum	Units	Notes
Output Optical Power BOL62.5/125 $\mu\text{m}$ , NA = 0.275 Fiber EOL	$P_O$	-19 -20	-15.7	-14	dBm avg	8
Output Optical Power BOL50/125 $\mu\text{m}$ , NA = 0.20 Fiber EOL	$P_O$	-22.5 -23.5		-14	dBm avg	8
Optical Extinction Ratio			0.02 -47	0.2 -27	%dB	9
Output Optical Power at Logic Low 0 State	$P_O$ ("0")			-45	dBm avg	10
Center Wavelength	$\lambda_C$	1270	1308	1380	nm	23, Figure 7
Spectral Width - FWHM Spectral Width - RMS	$\Delta\lambda$		14763		nm	11, 23 Figure 7
Optical Rise Time	$t_r$	0.6	2.1	3.0	ns	12, 23 Figure 7
Optical Fall Time	$t_f$	0.6	1.9	3.0	ns	12, 23 Figure 7
Systematic Jitter Contributed by the Transmitter OC-3	SJ		0.4	1.2	ns p-p	13a
Duty Cycle Distortion Contributed by the Transmitter FE	DCD		0.36	0.6	ns p-p	13b
Data Dependent Jitter Contributed by the Transmitter FE	DDJ		0.07	0.6	ns p-p	13c
Random Jitter Contributed by the Transmitter OC-3 FE	RJ		0.1 0.1	0.52 0.69	ns p-p	14a 14b

## Receiver Optical and Electrical Characteristics

HFBR-5961LZ/GZ ( $T_C = 0\text{ }^\circ\text{C}$  to  $+70\text{ }^\circ\text{C}$ ,  $V_{CC} = 2.97\text{ V}$  to  $3.63\text{ V}$ )

HFBR-5961ALZ/AGZ ( $T_C = -40\text{ }^\circ\text{C}$  to  $+85\text{ }^\circ\text{C}$ ,  $V_{CC} = 2.97\text{ V}$  to  $3.63\text{ V}$ )

Parameter	Symbol	Minimum	Typical	Maximum	Units	Notes
Input Optical Power at minimum at Window Edge	$P_{IN\ MIN}$ (W)					
OC-3				-30	dBm avg	15a, Figure 8
FE				-31		15b
Input Optical Power at Eye Center	$P_{IN\ MIN}$ (C)					
OC-3				-31	dBm avg	16a, Figure 8
FE				-31.8		16b
Input Optical Power Maximum	$P_{IN\ MAX}$	-14			dBm avg	15a
OC-3		-14				15b
FE		-14				
Operating Wavelength	$\lambda$	1270		1380	nm	
Systematic Jitter Contributed by the Receiver	SJ		0.2	1.2	ns p-p	17a
OC-3						
Duty Cycle Distortion Contributed by the Receiver	DCD		0.08	0.4	ns p-p	17b
FE						
Data Dependent Jitter Contributed by the Receiver FE	DDJ		0.07	1.0	ns p-p	17c
Random Jitter Contributed by the Receiver	RJ		0.3	1.91	ns p-p	18a
OC-3			0.3	2.14		18b
FE						
Signal Detect - Asserted	$P_A$	$P_D + 1.5\text{ dB}$				
OC-3				-31	dBm avg	19
FE				-33		
Signal Detect - Deasserted	$P_D$	-45			dBm avg	20
Signal Detect - Hysteresis	$P_A - P_D$	1.5			dB	
Signal Detect Assert Time (off to on)		0	2	100	$\mu\text{s}$	21
Signal Detect Deassert Time (on to off)		0	5	100	$\mu\text{s}$	22

### Notes:

- This is the maximum voltage that can be applied across the Differential Transmitter Data Inputs to prevent damage to the input ESD protection circuit.
- The outputs are terminated with  $50\ \Omega$  connected to  $V_{CC} - 2\text{ V}$ .
- The power supply current needed to operate the transmitter is provided to differential ECL circuitry. This circuitry maintains a nearly constant current flow from the power supply. Constant current operation helps to prevent unwanted electrical noise from being generated and conducted or emitted to neighboring circuitry.
- This value is measured with the outputs terminated into  $50\ \Omega$  connected to  $V_{CC} - 2\text{ V}$  and an Input Optical Power level of  $-14\text{ dBm}$  average.
- 5a. The power dissipation of the transmitter is calculated as the sum of the products of supply voltage and current.
- 5b. The power dissipation of the receiver is calculated as the sum of the products of supply voltage and currents, minus the sum of the products of the output voltages and currents.
- This value is measured with respect to  $V_{CC}$  with the output terminated into  $50\ \Omega$  connected to  $V_{CC} - 2\text{ V}$ .
- The data output rise and fall times are measured between 20% and 80% levels with the output connected to  $V_{CC} - 2\text{ V}$  through  $50\ \Omega$ .
- These optical power values are measured with the following conditions:  
The Beginning of life (BOL) to the End of Life (EOL) optical power degradation is typically  $1.5\text{ dB}$  per the industry convention for long wavelength LEDs. The actual degradation observed in Avago's  $1300\text{ nm}$  LED products is  $< 1\text{ dB}$ , as specified in this data sheet. Over the specified operating voltage and temperature ranges. With  $25\text{ MBd}$  ( $12.5\text{ MHz}$  square-wave), input signal. At the end of one meter of noted optical fiber with cladding modes removed. The average power value can be converted to a peak power value by adding  $3\text{ dB}$ . Higher output optical power transmitters are available on special request. Please consult with your local Avago sales representative for further details.

9. The Extinction Ratio is a measure of the modulation depth of the optical signal. The data "0" output optical power is compared to the data "1" peak output optical power and expressed as a percentage. With the transmitter driven by a 25 MBd (12.5 MHz square-wave) input signal, the average optical power is measured. The data "1" peak power is then calculated by adding 3 dB to the measured average optical power. The data "0" output optical power is found by measuring the optical power when the transmitter is driven by a logic "0" input. The extinction ratio is the ratio of the optical power at the "0" level compared to the optical power at the "1" level expressed as a percentage or in decibels.
10. The transmitter will provide this low level of Output Optical Power when driven by a Logic "0" input. This can be useful in link troubleshooting.
11. The relationship between Full Width Half Maximum and RMS values for Spectral Width is derived from the assumption of a Gaussian shaped spectrum which results in a  $2.35 \times \text{RMS} = \text{FWHM}$  relationship.
12. The optical rise and fall times are measured from 10% to 90% when the transmitter is driven by a 25 MBd (12.5 MHz square-wave) input signal. The ANSI T1E1.2 committee has designated the possibility of defining an eye pattern mask for the transmitter optical output as an item for further study. Avago will incorporate this requirement into the specifications for these products if it is defined. The HFBR-59XXL products typically comply with the template requirements of CCITT (now ITU-T) G.957 Section 3.2.5, Figure 5 for the STM-1 rate, excluding the optical receiver filter normally associated with single mode fiber measurements which is the likely source for the ANSI T1E1.2 committee to follow in this matter.
- 13a. Systematic Jitter contributed by the transmitter is defined as the combination of Duty Cycle Distortion and Data Dependent Jitter. Systematic Jitter is measured at 50% threshold using a 155.52 MBd (77.5 MHz square-wave),  $2^{23}-1$  pseudorandom data pattern input signal.
- 13b. Duty Cycle Distortion contributed by the transmitter is measured at the 50% threshold of the optical output signal using an IDLE Line State, 125 MBd (62.5 MHz square-wave), input signal.
- 13c. Data Dependent Jitter contributed by the transmitter is specified with the FDDI test pattern described in FDDI PMD Annex A.5.
- 14a. Random Jitter contributed by the transmitter is specified with a 155.52 MBd (77.5 MHz square-wave) input signal.
- 14b. Random Jitter contributed by the transmitter is specified with an IDLE Line State, 125 MBd (62.5 MHz square-wave), input signal. See Application Information - Transceiver Jitter Performance Section of this data sheet for further details.
- 15a. This specification is intended to indicate the performance of the receiver section of the transceiver when Input Optical Power signal characteristics are present per the following definitions. The Input Optical Power dynamic range from the minimum level (with a window time-width) to the maximum level is the range over which the receiver is guaranteed to provide output data with a Bit Error Rate (BER) better than or equal to  $1 \times 10^{-10}$ .
- At the Beginning of Life (BOL) over the specified operating temperature and voltage ranges 23 input is a 155.52 MBd, 2 - 1 PRBS data pattern with 72 "1"s and 72 "0"s inserted per the CCITT (now ITU-T) recommendation G.958 Appendix I. Receiver data window time-width is 1.23 ns or greater for the clock recovery circuit to operate in. The actual test data window time-width is set to simulate the effect of worst case optical input jitter based on the transmitter jitter values from the specification tables. The test window time-width is HFBR-5961L 3.32 ns.
- Transmitter operating with a 155.52 MBd, 77.5 MHz square-wave, input signal to simulate any cross-talk present between the transmitter and receiver sections of the transceiver.
- 15b. This specification is intended to indicate the performance of the receiver section of the transceiver when Input Optical Power signal characteristics are present per the following definitions. The Input Optical Power dynamic range from the minimum level (with a window time-width) to the maximum level is the range over which the receiver is guaranteed to provide output data with a Bit Error Rate (BER) better than or equal to  $2.5 \times 10^{-10}$ .
- At the Beginning of Life (BOL)
  - Over the specified operating temperature and voltage ranges
  - Input symbol pattern is the FDDI test pattern defined in FDDI PMD Annex A.5 with 4B/5B NRZI encoded data that contains a duty cycle baseline wander effect of 50 kHz. This sequence causes a near worst case condition for inter-symbol interference.
  - Receiver data window time-width is 2.13 ns or greater and centered at mid-symbol. This worst case window time-width is the minimum allowed eye-opening presented to the FDDI PHY PM<sub>U</sub> Data indication input (PHY input) per the example in FDDI PMD Annex E. This minimum window time-width of 2.13 ns is based upon the worst case FDDI PMD Active Input Interface optical conditions for peak-to-peak DCD (1.0 ns), DDJ (1.2 ns) and RJ (0.76 ns) presented to the receiver.
- To test a receiver with the worst case FDDI PMD Active Input jitter condition requires exacting control over DCD, DDJ and RJ jitter components that is difficult to implement with production test equipment. The receiver can be equivalently tested to the worst case FDDI PMD input jitter conditions and meet the minimum output data window time-width of 2.13 ns. This is accomplished by using a nearly ideal input optical signal (no DCD, insignificant DDJ and RJ) and measuring for a wider window time-width of 4.6 ns. This is possible due to the cumulative effect of jitter components through their superposition (DCD and DDJ are directly additive and RJ components are rms additive). Specifically, when a nearly ideal input optical test signal is used and the maximum receiver peak-to-peak jitter contributions of DCD (0.4 ns), DDJ (1.0 ns), and RJ (2.14 ns) exist, the minimum window time-width becomes  $8.0 \text{ ns} - 0.4 \text{ ns} - 1.0 \text{ ns} - 2.14 \text{ ns} = 4.46 \text{ ns}$ , or conservatively 4.6 ns. This wider window time-width of 4.6 ns guarantees the FDDI PMD Annex E minimum window time-width of 2.13 ns under worst case input jitter conditions to the Avago receiver.
- Transmitter operating with an IDLE Line State pattern, 125 MBd (62.5 MHz square-wave), input signal to simulate any cross-talk present between the transmitter and receiver sections of the transceiver.
- 16a. All conditions of Note 15a apply except that the measurement is made at the center of the symbol with no window time-width.
- 16b. All conditions of Note 15b apply except that the measurement is made at the center of the symbol with no window time-width.
- 17a. Systematic Jitter contributed by the receiver is defined as the combination of Duty Cycle Distortion and Data Dependent Jitter. Systematic Jitter is measured at 50% threshold using a 155.52 MBd (77.5 MHz square-wave),  $2^{23}-1$  pseudorandom data pattern input signal.
- 17b. Duty Cycle Distortion contributed by the receiver is measured at the 50% threshold of the electrical output signal using an IDLE Line State, 125 MBd (62.5 MHz square-wave), input signal. The input optical power level is -20 dBm average.
- 17c. Data Dependent Jitter contributed by the receiver is specified with the FDDI DDJ test pattern described in the FDDI PMD Annex A.5. The input optical power level is -20 dBm average.
- 18a. Random Jitter contributed by the receiver is specified with a 155.52 MBd (77.5 MHz square-wave) input signal.
- 18b. Random Jitter contributed by the receiver is specified with an IDLE Line State, 125 MBd (62.5 MHz square-wave), input signal. The input optical power level is at maximum "P<sub>IN Min. (W)</sub>". See Application Information - Transceiver Jitter Section for further information.

19. This value is measured during the transition from low to high levels of input optical power.
20. This value is measured during the transition from high to low levels of input optical power. At Signal Detect Deassert, the receiver outputs Data Out and Data Out Bar go to steady PECL levels High and Low respectively.
21. The Signal Detect output shall be asserted within 100 us after a step increase of the Input Optical Power.
22. Signal detect output shall be de-asserted within 350  $\mu$ s after a step decrease in the Input Optical Power. At Signal Detect Deassert, the receiver outputs Data Out and Data Out Bar go to steady PECL levels High and Low respectively.
23. The HFBR-5961L transceiver complies with the requirements for the trade-offs between center wavelength, spectral width, and rise/fall times shown in Figure 7. This figure is derived from the FDDI PMD standard (ISO/IEC 9314-3 : 1990 and ANSI X3.166 - 1990) per the description in ANSI T1E1.2 Revision 3. The interpretation of this figure is that values of Center Wavelength and Spectral Width must lie along the appropriate Optical Rise/Fall Time curve.

## Ordering Information

### 1300 nm LED (Operating Case Temperature 0 to +70 °C)

HFBR-5961LZ/HFBR-5961GZ

### 1300 nm LED (Operating Case Temperature -40 to +85 °C)

HFBR-5961ALZ/HFBR-5961AGZ

For product information and a complete list of distributors, please go to our web site: [www.avagotech.com](http://www.avagotech.com)



Avago, Avago Technologies, and the A logo are trademarks of Avago Technologies in the United States and other countries.  
Data subject to change. Copyright © 2005-2009 Avago Technologies. All rights reserved.

AV02-0820EN - April 24, 2009



## Looking for pricing, stock, or lifecycle information?

Click below to explore more details on WIN SOURCE:

-  [View HFBR-5961ALZ on WIN SOURCE](#)
-  [Broadcom Limited Information](#)

## Optimize Your Supply Chain with WIN SOURCE Solutions

-  Global Sourcing Solution
-  Obsolete Management
-  Cost Control Management
-  Shortage Management
-  Alternative Solution
-  Excess Inventory Management