

HEF4511B

BCD to 7-segment latch/decoder/driver

Rev. 7 — 11 November 2011

Product data sheet

1. General description

The HEF4511B is a BCD to 7-segment latch/decoder/driver with four address inputs (D0 to D3), an active HIGH latch enable input (LE), an active LOW ripple blanking input ($\overline{\text{BL}}$), an active LOW lamp test input ($\overline{\text{LT}}$), and seven active HIGH NPN bipolar transistor segment outputs (Qa to Qg).

When LE is LOW and $\overline{\text{BL}}$ is HIGH, the state of the segment outputs (Qa to Qg) is determined by the data on D0 to D3. When LE goes HIGH, the last data present on D0 to D3 is stored in the latches and the segment outputs remain unchanged. When $\overline{\text{LT}}$ is LOW, all of the segment outputs are HIGH independent of all other input conditions. With $\overline{\text{LT}}$ HIGH, a LOW on $\overline{\text{BL}}$ forces all segment outputs LOW. The inputs $\overline{\text{LT}}$ and $\overline{\text{BL}}$ do not affect the latch circuit.

It operates over a recommended V_{DD} power supply range of 3 V to 15 V referenced to V_{SS} (usually ground). Unused inputs must be connected to V_{DD} , V_{SS} , or another input.

2. Features and benefits

- Fully static operation
- 5 V, 10 V, and 15 V parametric ratings
- Standardized symmetrical output characteristics
- Specified from $-40\text{ }^{\circ}\text{C}$ to $+85\text{ }^{\circ}\text{C}$ and $-40\text{ }^{\circ}\text{C}$ to $+125\text{ }^{\circ}\text{C}$
- Complies with JEDEC standard JESD 13-B

3. Ordering information

Table 1. Ordering information

All types operate from $-40\text{ }^{\circ}\text{C}$ to $+125\text{ }^{\circ}\text{C}$.

Type number	Package		Version
	Name	Description	
HEF4511BP	DIP16	plastic dual in-line package; 16 leads (300 mil)	SOT38-4
HEF4511BT	SO16	plastic small outline package; 16 leads; body width 3.9 mm	SOT109-1



4. Functional diagram

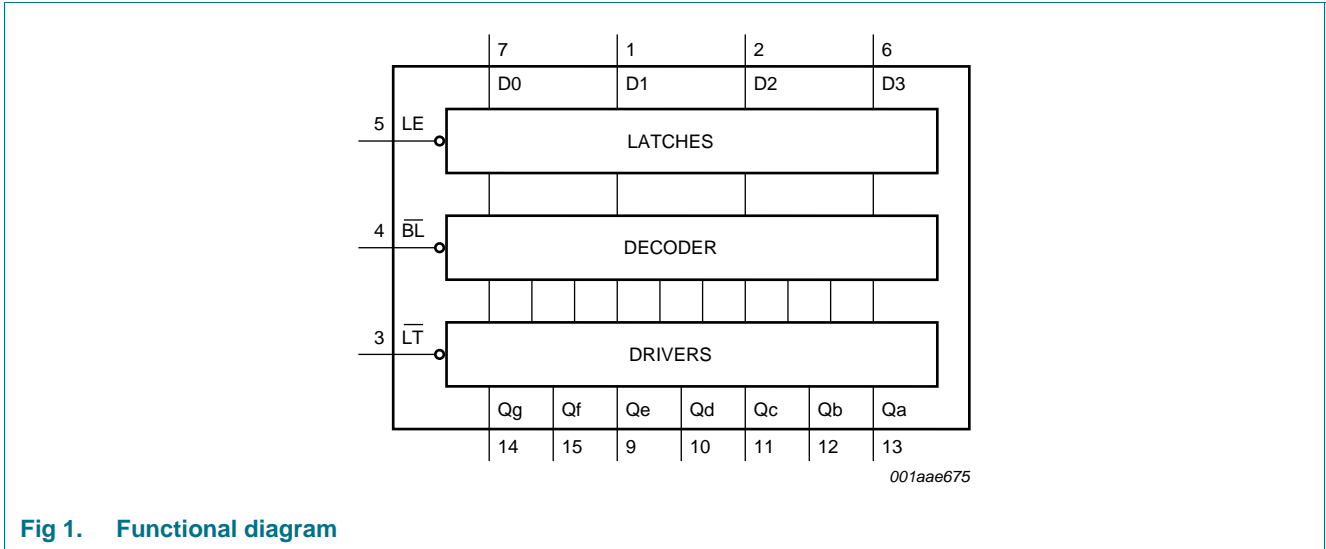

Fig 1. Functional diagram

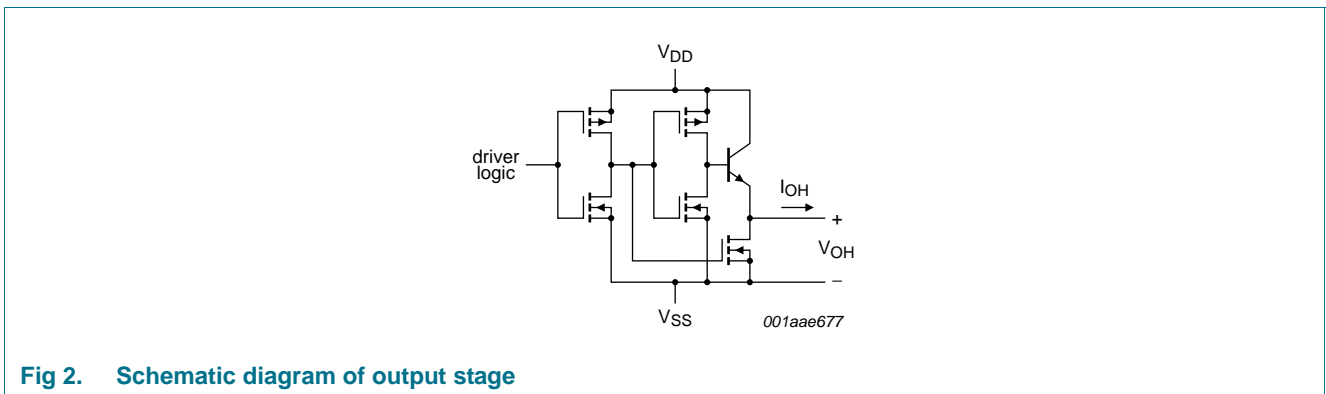

Fig 2. Schematic diagram of output stage

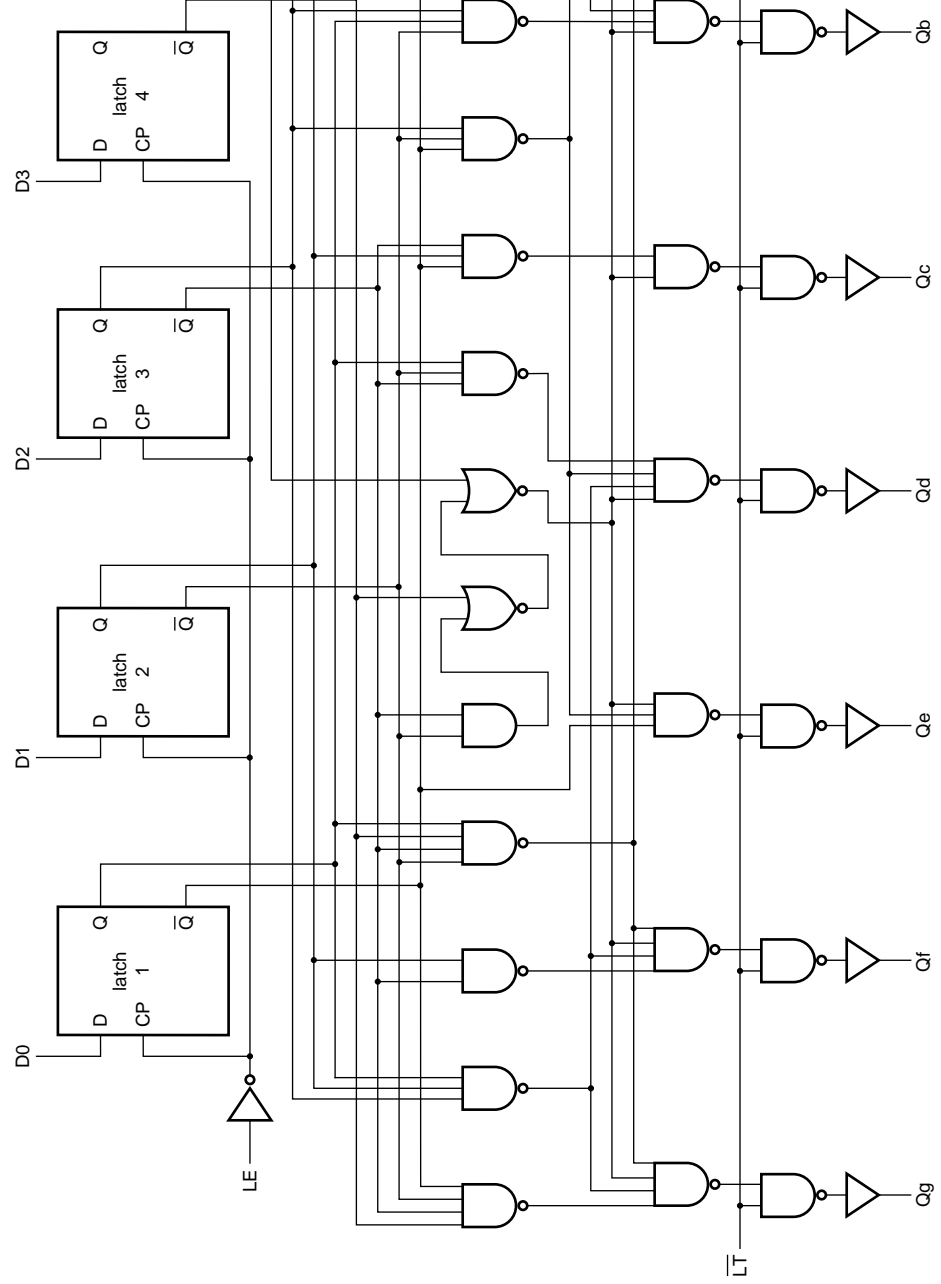
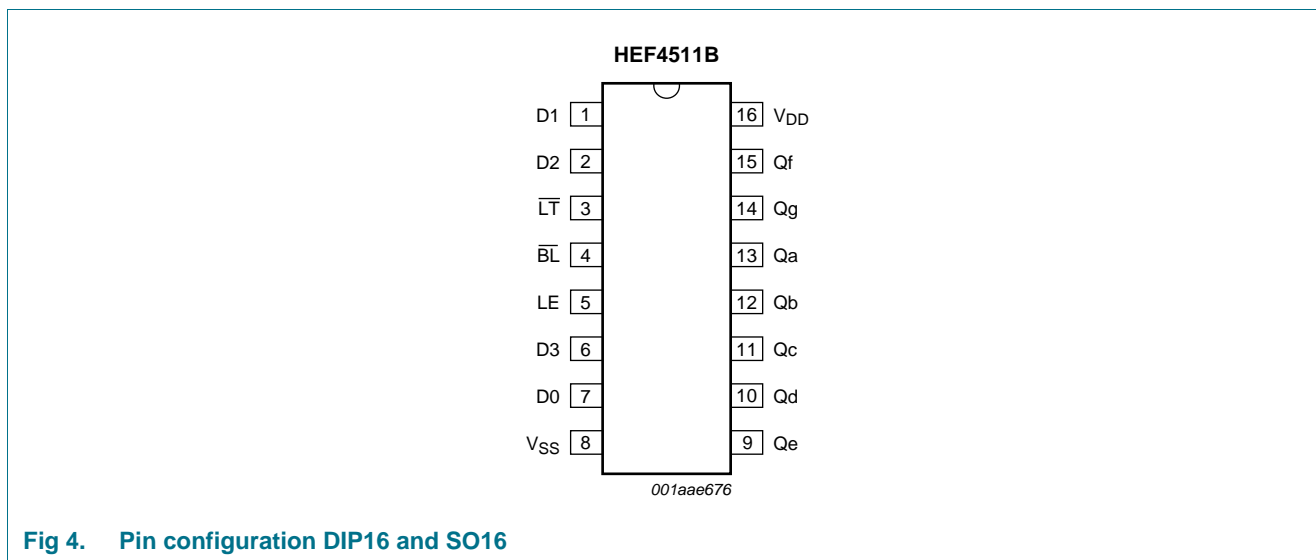

Fig 3. Logic diagram

5. Pinning information

5.1 Pinning



5.2 Pin description

Table 2. Pin description

Symbol	Pin	Description
$\overline{\text{LT}}$	3	lamp test input (active LOW)
$\overline{\text{BL}}$	4	ripple blanking input (active LOW)
LE	5	latch enable input (active HIGH)
D0 to D3	7, 1, 2, 6	address (data) input
V _{SS}	8	ground supply voltage
Qa to Qg	13, 12, 11, 10, 9, 15, 14	segment output
V _{DD}	16	supply voltage

6. Functional description

Table 3. Function table^[1]

Inputs							Outputs							Display
LE	$\overline{\text{BL}}$	$\overline{\text{LT}}$	D3	D2	D1	D0	Qa	Qb	Qc	Qd	Qe	Qf	Qg	
X	X	L	X	X	X	X	H	H	H	H	H	H	H	8
X	L	H	X	X	X	X	L	L	L	L	L	L	L	blank
L	H	H	L	L	L	L	H	H	H	H	H	H	L	0
L	H	H	L	L	L	H	L	H	H	L	L	L	L	1
L	H	H	L	L	H	L	H	H	L	H	H	L	H	2
L	H	H	L	L	H	H	H	H	H	H	L	L	H	3
L	H	H	L	H	L	L	L	H	H	L	L	H	H	4
L	H	H	L	H	L	H	H	L	H	H	L	H	H	5
L	H	H	L	H	H	L	L	L	H	H	H	H	H	6
L	H	H	L	H	H	H	H	H	H	L	L	L	L	7
L	H	H	H	L	L	L	H	H	H	H	H	H	H	8
L	H	H	H	L	L	H	H	H	H	L	L	H	H	9
L	H	H	H	L	H	X	L	L	L	L	L	L	L	blank
L	H	H	H	H	X	X	L	L	L	L	L	L	L	blank
H	H	H	X	X	X	X	N.C.	N.C.	N.C.	N.C.	N.C.	N.C.	N.C.	N.C.

[1] H = HIGH voltage level; L = LOW voltage level; X = don't care; N.C. = no change.

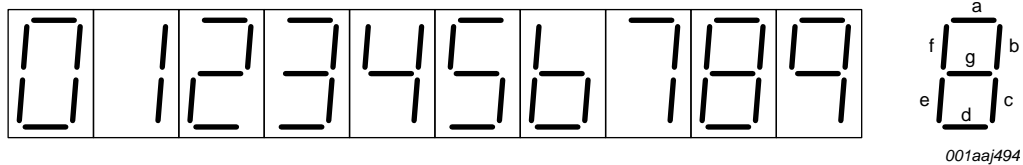

Fig 5. Seven segment digital display with segment designation

7. Limiting values

Table 4. Limiting values

In accordance with the Absolute Maximum Rating System (IEC 60134).

Symbol	Parameter	Conditions	Min	Max	Unit
V_{DD}	supply voltage		-0.5	+18	V
I_{IK}	input clamping current	$V_I < -0.5\text{ V}$ or $V_I > V_{DD} + 0.5\text{ V}$	-	± 10	mA
V_I	input voltage		-0.5	$V_{DD} + 0.5$	V
I_{OK}	output clamping current	$V_O < -0.5\text{ V}$ or $V_O > V_{DD} + 0.5\text{ V}$	-	± 10	mA
$I_{I/O}$	input/output current		-	± 10	mA
I_{OH}	HIGH-level output current		[1] -25	-	mA
I_{DD}	supply current		-	50	mA
T_{stg}	storage temperature		-65	+150	°C
T_{amb}	ambient temperature		-40	+125	°C
P_{tot}	total power dissipation	$T_{amb} = 125\text{ °C}$			
		DIP16 package	[2] -	750	mW
		SO16 package	[3] -	500	mW
P	power dissipation	per output	-	100	mW

[1] A destructive high current mode may occur if V_I and V_O are not constrained to the range $V_{SS} \leq V_I$ or $V_O \leq V_{DD}$.

[2] For DIP16 package: P_{tot} derates linearly with 12 mW/K above 70 °C.

[3] For SO16 package: P_{tot} derates linearly with 8 mW/K above 70 °C.

8. Recommended operating conditions

Table 5. Recommended operating conditions

Symbol	Parameter	Conditions	Min	Typ	Max	Unit
V_{DD}	supply voltage		3	-	15	V
V_I	input voltage		0	-	V_{DD}	V
T_{amb}	ambient temperature	in free air	-40	-	+125	°C
$\Delta t/\Delta V$	input transition rise and fall rate	$V_{DD} = 5\text{ V}$	-	-	3.75	$\mu\text{s/V}$
		$V_{DD} = 10\text{ V}$	-	-	0.5	$\mu\text{s/V}$
		$V_{DD} = 15\text{ V}$	-	-	0.08	$\mu\text{s/V}$

9. Static characteristics

Table 6. Static characteristics

$V_{SS} = 0\text{ V}$; $V_I = V_{SS}$ or V_{DD} ; unless otherwise specified.

Symbol	Parameter	Conditions	V_{DD}	$T_{amb} = -40\text{ °C}$		$T_{amb} = +25\text{ °C}$		$T_{amb} = +85\text{ °C}$		$T_{amb} = +125\text{ °C}$		Unit
				Min	Max	Min	Max	Min	Max	Min	Max	
V_{IH}	HIGH-level input voltage	$ I_O < 1\text{ }\mu\text{A}$	5 V	3.5	-	3.5	-	3.5	-	3.5	-	V
			10 V	7.0	-	7.0	-	7.0	-	7.0	-	V
			15 V	11.0	-	11.0	-	11.0	-	11.0	-	V
V_{IL}	LOW-level input voltage	$ I_O < 1\text{ }\mu\text{A}$	5 V	-	1.5	-	1.5	-	1.5	-	1.5	V
			10 V	-	3.0	-	3.0	-	3.0	-	3.0	V
			15 V	-	4.0	-	4.0	-	4.0	-	4.0	V
V_{OH}	HIGH-level output voltage	see Table 7	-	-	-	-	-	-	-	-	-	
V_{OL}	LOW-level output voltage	$ I_O < 1\text{ }\mu\text{A}$	5 V	-	0.05	-	0.05	-	0.05	-	0.05	V
			10 V	-	0.05	-	0.05	-	0.05	-	0.05	V
			15 V	-	0.05	-	0.05	-	0.05	-	0.05	V
I_{OH}	HIGH-level output current	$V_O = 2.5\text{ V}$	5 V	-	-1.7	-	-1.4	-	-1.1	-	-1.1	mA
		$V_O = 4.6\text{ V}$	5 V	-	-0.64	-	-0.5	-	-0.36	-	-0.36	mA
		$V_O = 9.5\text{ V}$	10 V	-	-1.6	-	-1.3	-	-0.9	-	-0.9	mA
		$V_O = 13.5\text{ V}$	15 V	-	-4.2	-	-3.4	-	-2.4	-	-2.4	mA
I_{OL}	LOW-level output current	$V_O = 0.4\text{ V}$	5 V	0.64	-	0.5	-	0.36	-	0.36	-	mA
		$V_O = 0.5\text{ V}$	10 V	1.6	-	1.3	-	0.9	-	0.9	-	mA
		$V_O = 1.5\text{ V}$	15 V	4.2	-	3.4	-	2.4	-	2.4	-	mA
I_I	input leakage current		15 V	-	± 0.1	-	± 0.1	-	± 1.0	-	± 1.0	μA
I_{DD}	supply current	$I_O = 0\text{ A}$	5 V	-	5	-	5	-	150	-	150	μA
			10 V	-	10	-	10	-	300	-	300	μA
			15 V	-	20	-	20	-	600	-	600	μA
C_I	input capacitance		-	-	-	7.5	-	-	-	-	pF	

Table 7. Static characteristics for V_{OH}

$V_{SS} = 0\text{ V}$.

Symbol	Parameter	I_{OH} mA	V_{DD} V	$T_{amb} = -40\text{ °C}$		$T_{amb} = +25\text{ °C}$		$T_{amb} = +85\text{ °C}$		$T_{amb} = +125\text{ °C}$		Unit
				Min	Min	Typ	Min	Min				
V_{OH}	HIGH-level output voltage	0	5 V	4.10	4.10	4.40	4.10	4.10	V			
			10 V	9.10	9.10	9.90	9.10	9.10	V			
			15 V	14.10	14.10	14.40	14.10	14.10	V			
		5	5 V	-	-	4.30	-	-	V			
			10 V	-	-	9.30	-	-	V			
			15 V	-	-	14.30	-	-	V			
		10	5 V	3.60	3.60	4.25	3.30	3.20	V			
			10 V	8.75	8.75	9.25	8.45	8.35	V			
			15 V	13.75	13.75	14.30	13.45	13.35	V			
		15	5 V	-	-	4.20	-	-	V			
			10 V	-	-	9.20	-	-	V			
			15 V	-	-	14.20	-	-	V			
		20	5 V	2.80	2.80	4.20	2.50	2.30	V			
			10 V	8.10	8.10	9.20	7.80	7.60	V			
			15 V	13.10	13.10	14.20	12.80	12.60	V			
		25	5 V	-	-	4.15	-	-	V			
			10 V	-	-	9.20	-	-	V			
			15 V	-	-	14.20	-	-	V			

10. Dynamic characteristics

Table 8. Dynamic characteristics

$V_{SS} = 0\text{ V}$; $T_{amb} = 25\text{ °C}$; for test circuit see [Figure 8](#).

Symbol	Parameter	Conditions	V_{DD}	Extrapolation formula ^[1]	Min	Typ	Max	Unit
t_{PHL}	HIGH to LOW propagation delay	$D_n \rightarrow Q_n$; see Figure 6	5 V	$128\text{ ns} + (0.55\text{ ns/pF})C_L$	-	155	310	ns
			10 V	$49\text{ ns} + (0.23\text{ ns/pF})C_L$	-	60	120	ns
			15 V	$32\text{ ns} + (0.16\text{ ns/pF})C_L$	-	40	80	ns
		$LE \rightarrow Q_n$; see Figure 6	5 V	$133\text{ ns} + (0.55\text{ ns/pF})C_L$	-	160	320	ns
			10 V	$49\text{ ns} + (0.23\text{ ns/pF})C_L$	-	60	120	ns
			15 V	$37\text{ ns} + (0.16\text{ ns/pF})C_L$	-	45	90	ns
		$\overline{BL} \rightarrow Q_n$; see Figure 6	5 V	$93\text{ ns} + (0.55\text{ ns/pF})C_L$	-	120	240	ns
			10 V	$39\text{ ns} + (0.23\text{ ns/pF})C_L$	-	50	100	ns
			15 V	$27\text{ ns} + (0.16\text{ ns/pF})C_L$	-	35	70	ns
		$\overline{LT} \rightarrow Q_n$; see Figure 6	5 V	$52\text{ ns} + (0.55\text{ ns/pF})C_L$	-	80	160	ns
			10 V	$19\text{ ns} + (0.23\text{ ns/pF})C_L$	-	30	60	ns
			15 V	$12\text{ ns} + (0.16\text{ ns/pF})C_L$	-	20	40	ns

Table 8. Dynamic characteristics ...continued
 $V_{SS} = 0\text{ V}$; $T_{amb} = 25\text{ °C}$; for test circuit see [Figure 8](#).

Symbol	Parameter	Conditions	V _{DD}	Extrapolation formula ^[1]	Min	Typ	Max	Unit
t _{PLH}	LOW to HIGH propagation delay	D _n → Q _n ; see Figure 6	5 V	108 ns + (0.55 ns/pF)C _L	-	135	270	ns
			10 V	44 ns + (0.23 ns/pF)C _L	-	55	110	ns
			15 V	32 ns + (0.16 ns/pF)C _L	-	40	80	ns
		LE → Q _n ; see Figure 6	5 V	133 ns + (0.55 ns/pF)C _L	-	160	320	ns
			10 V	59 ns + (0.23 ns/pF)C _L	-	70	140	ns
			15 V	42 ns + (0.16 ns/pF)C _L	-	50	100	ns
		B _L → Q _n ; see Figure 6	5 V	78 ns + (0.55 ns/pF)C _L	-	105	210	ns
			10 V	29 ns + (0.23 ns/pF)C _L	-	40	80	ns
			15 V	22 ns + (0.16 ns/pF)C _L	-	30	60	ns
	L _T → Q _n ; see Figure 6	5 V	33 ns + (0.55 ns/pF)C _L	-	60	120	ns	
		10 V	19 ns + (0.23 ns/pF)C _L	-	30	60	ns	
		15 V	17 ns + (0.16 ns/pF)C _L	-	25	50	ns	
t _{THL}	HIGH to LOW output transition time	see Figure 6	5 V	10 ns + (1.00 ns/pF)C _L	-	60	120	ns
			10 V	9 ns + (0.42 ns/pF)C _L	-	30	60	ns
			15 V	6 ns + (0.28 ns/pF)C _L	-	20	40	ns
t _{TLH}	LOW to HIGH output transition time	see Figure 6	5 V	20 ns + (1.00 ns/pF)C _L	-	25	50	ns
			10 V	13 ns + (0.06 ns/pF)C _L	-	16	32	ns
			15 V	10 ns + (0.06 ns/pF)C _L	-	13	26	ns
t _{su}	set-up time	D _n → LE; see Figure 7	5 V		50	25	-	ns
			10 V		25	12	-	ns
			15 V		20	9	-	ns
t _h	hold time	D _n → LE; see Figure 7	5 V		60	30	-	ns
			10 V		30	15	-	ns
			15 V		25	12	-	ns
t _w	pulse width	LE input LOW; minimum width; see Figure 7	5 V		80	40	-	ns
			10 V		40	20	-	ns
			15 V		35	17	-	ns

[1] The typical values of the propagation delay and transition times are calculated from the extrapolation formulas shown (C_L in pF).

Table 9. Dynamic power dissipation P_D

P_D can be calculated from the formulas shown. $V_{SS} = 0\text{ V}$; $t_r = t_f \leq 20\text{ ns}$; $T_{amb} = 25\text{ °C}$.

Symbol	Parameter	V _{DD}	Typical formula for P _D (μW)	where:
P _D	dynamic power dissipation	5 V	$P_D = 1000 \times f_i + \Sigma(f_o \times C_L) \times V_{DD}^2$	f _i = input frequency in MHz;
		10 V	$P_D = 4000 \times f_i + \Sigma(f_o \times C_L) \times V_{DD}^2$	f _o = output frequency in MHz;
		15 V	$P_D = 10000 \times f_i + \Sigma(f_o \times C_L) \times V_{DD}^2$	C _L = output load capacitance in pF; V _{DD} = supply voltage in V; Σ(f _o × C _L) = sum of the outputs.

11. Waveforms

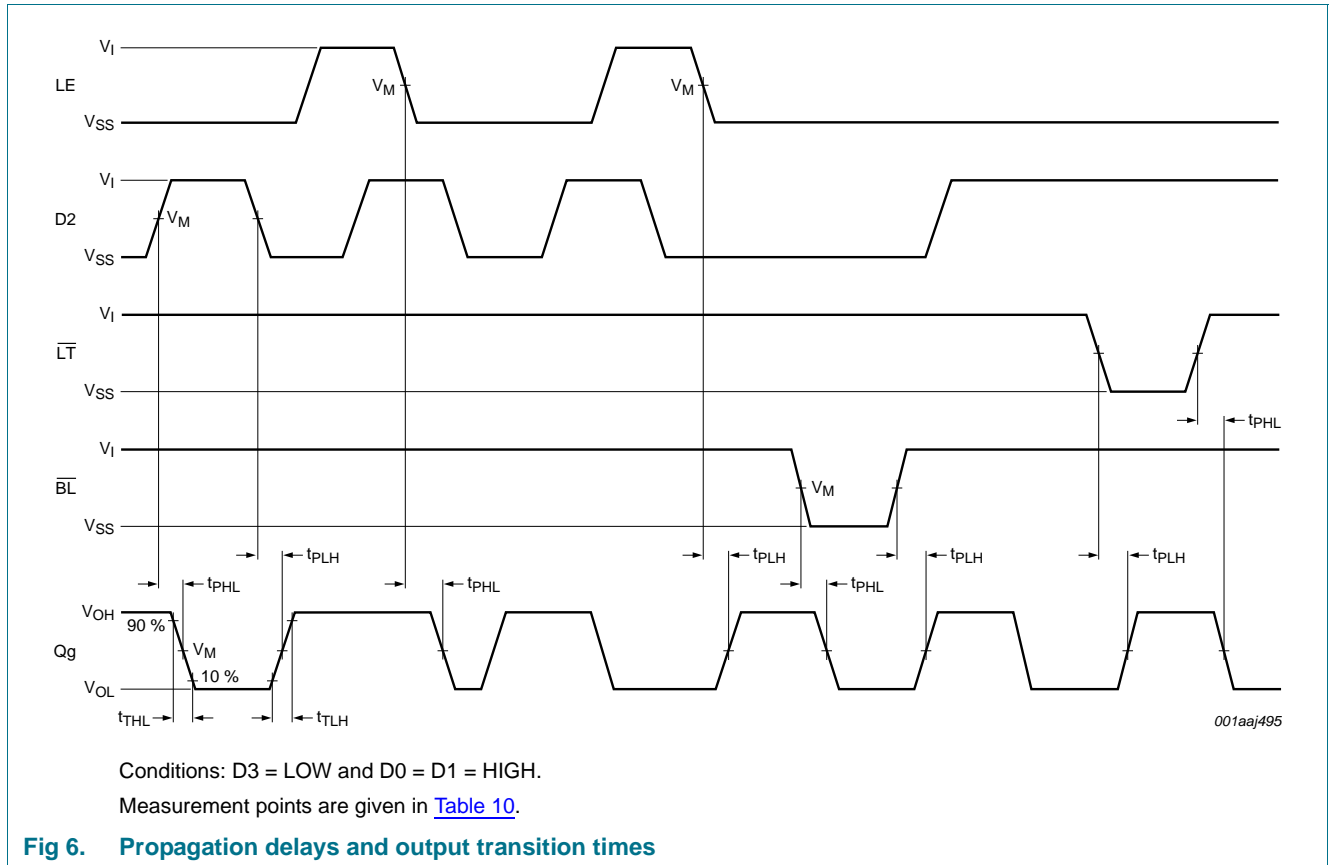

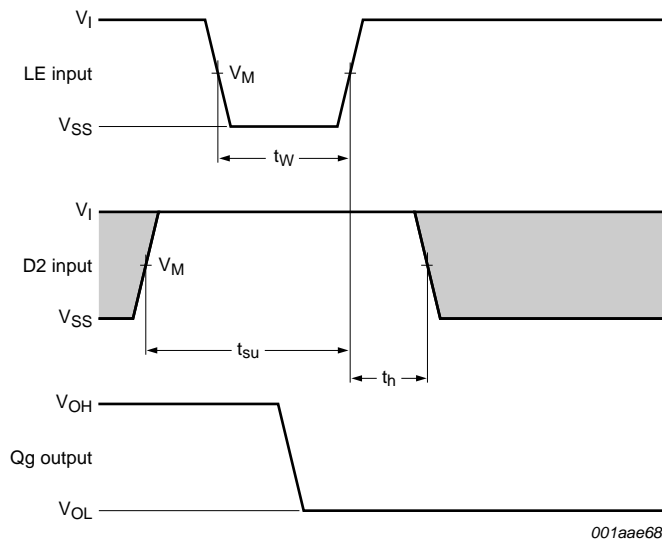

The shaded area indicates where the input is permitted to change for predictable output performance.
 Conditions: D3 = LOW and D0 = D1 = \overline{BL} = \overline{LT} = HIGH.
 Measurement points are given in [Table 10](#).

Fig 7. Waveforms showing minimum LE pulse width, set-up, and hold time for Dn to LE

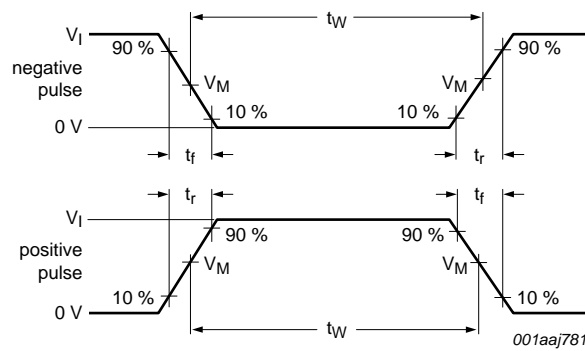

a. Input waveforms

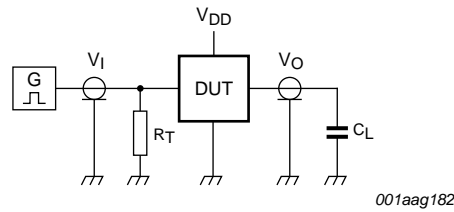

b. Test circuit

Test data is given in [Table 10](#).

Definitions for test circuit:

DUT = Device Under Test.

C_L = Load capacitance including jig and probe capacitance.

R_T = Termination resistance should be equal to output impedance Z_o of the pulse generator.

Fig 8. Test circuit for measuring switching times

Table 10. Measurement points and test data

Supply voltage	Input			Load
	V_I	V_M	t_r, t_f	C_L
5 V to 15 V	V_{DD}	$0.5V_I$	≤ 20 ns	50 pF

12. Application information

- Driving LED displays
- Driving incandescent displays
- Driving fluorescent displays
- Driving LCD displays
- Driving gas discharge displays

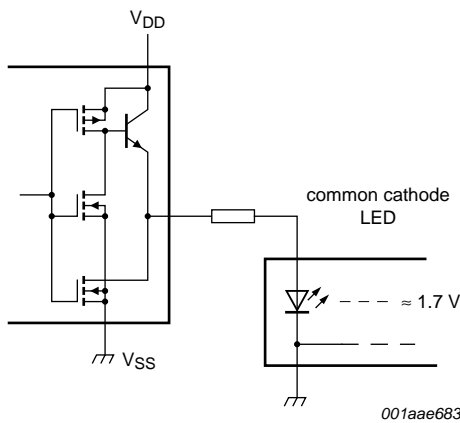

Fig 9. Connection to common cathode LED display readout

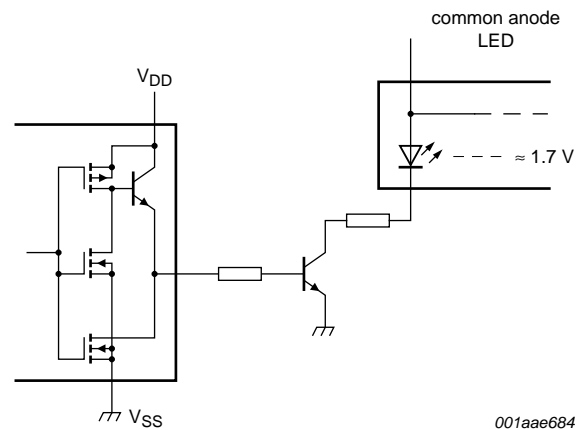
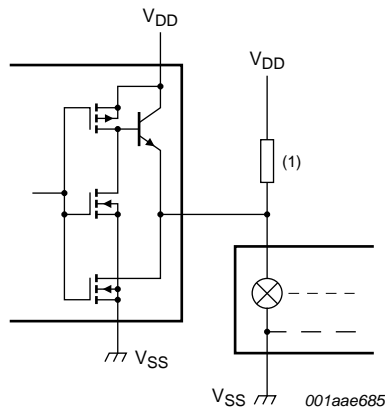

Fig 10. Connection to common anode LED display readout



(1) A filament pre-warm resistor is recommended to reduce filament thermal shock and increase the effective cold resistance of the filament.

Fig 11. Connection to incandescent display readout

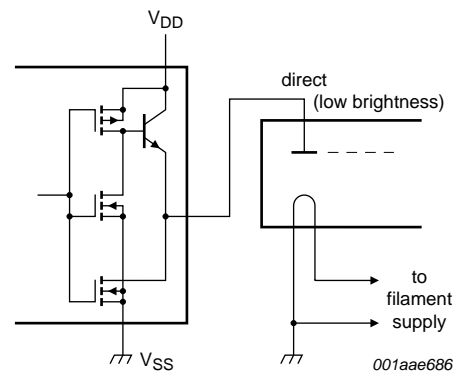

Fig 12. Connection to fluorescent display readout

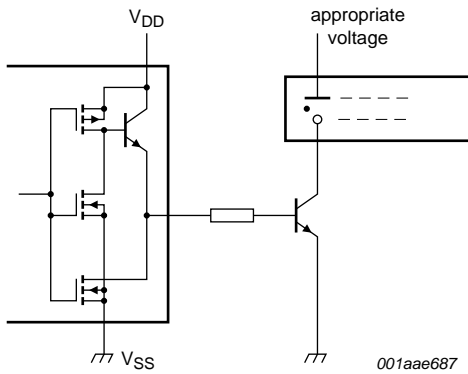
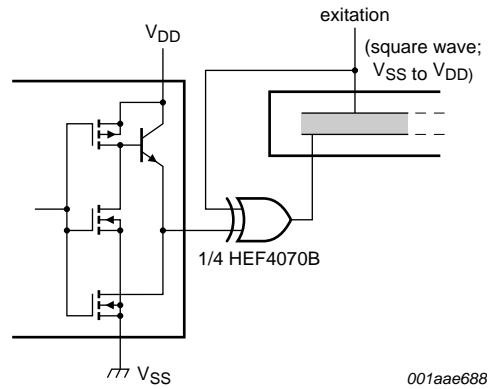

Fig 13. Connection to gas discharge display readout



Direct DC drive of LCDs not recommended for life of LCD readouts.

Fig 14. Connection to LCD readout

13. Package outline

DIP16: plastic dual in-line package; 16 leads (300 mil)

SOT38-4

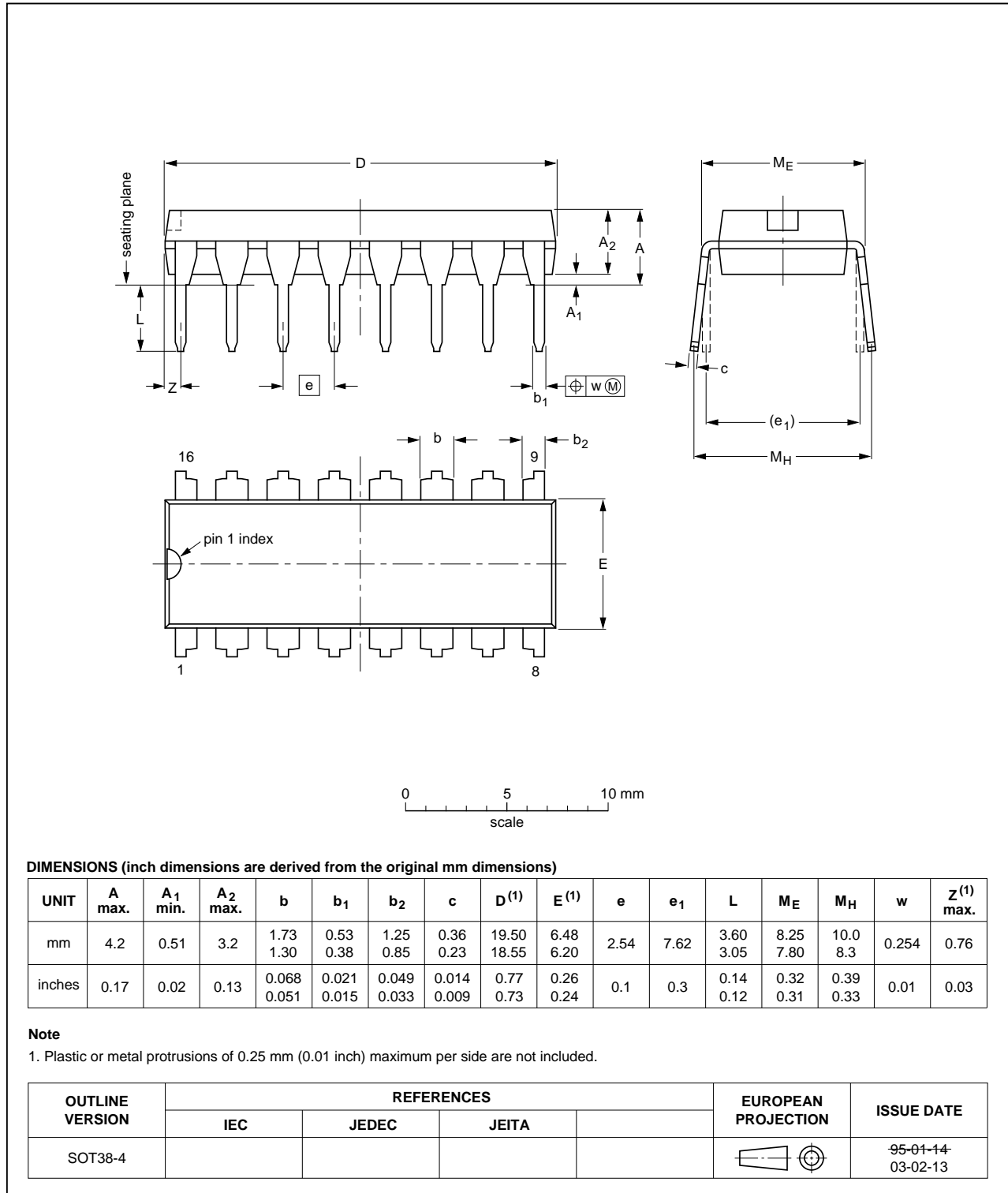

Fig 15. Package outline SOT38-4 (DIP16)

SO16: plastic small outline package; 16 leads; body width 3.9 mm

SOT109-1

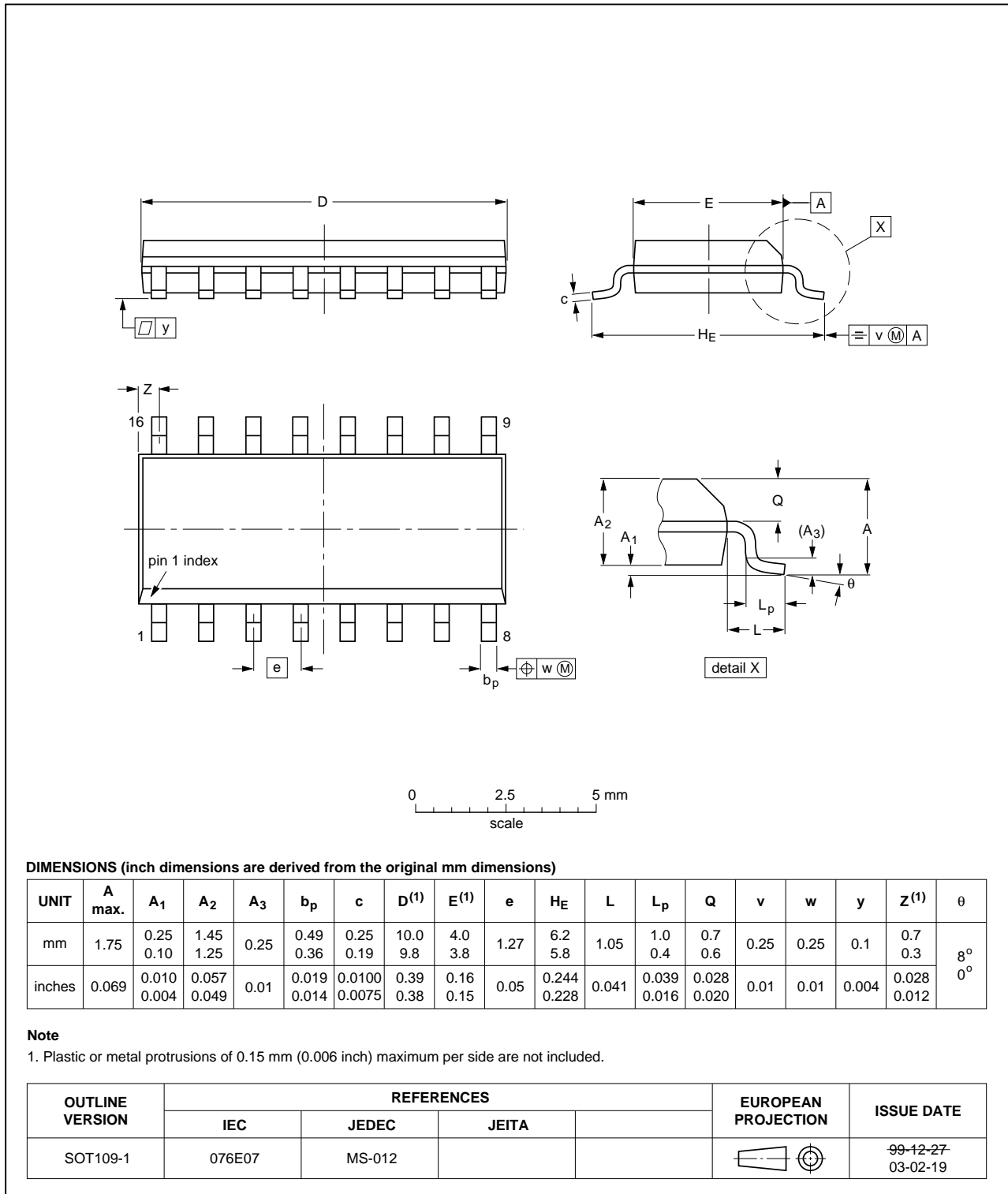

Fig 16. Package outline SOT109-1 (SO16)

14. Revision history

Table 11. Revision history

Document ID	Release date	Data sheet status	Change notice	Supersedes
HEF4511B v.7	20111111	Product data sheet	-	HEF4511B v.6
Modifications:	<ul style="list-style-type: none">• Section Applications removed• Table 6: I_{OH} minimum values changed to maximum			
HEF4511B v.6	20091207	Product data sheet	-	HEF4511B v.5
HEF4511B v.5	20090813	Product data sheet	-	HEF4511B v.4
HEF4511B v.4	20090305	Product data sheet	-	HEF4511B_CNV v.3
HEF4511B_CNV v.3	19950101	Product specification	-	HEF4511B_CNV v.2
HEF4511B_CNV v.2	19950101	Product specification	-	-

15. Legal information

15.1 Data sheet status

Document status ^{[1][2]}	Product status ^[3]	Definition
Objective [short] data sheet	Development	This document contains data from the objective specification for product development.
Preliminary [short] data sheet	Qualification	This document contains data from the preliminary specification.
Product [short] data sheet	Production	This document contains the product specification.

[1] Please consult the most recently issued document before initiating or completing a design.

[2] The term 'short data sheet' is explained in section "Definitions".

[3] The product status of device(s) described in this document may have changed since this document was published and may differ in case of multiple devices. The latest product status information is available on the Internet at URL <http://www.nxp.com>.

15.2 Definitions

Draft — The document is a draft version only. The content is still under internal review and subject to formal approval, which may result in modifications or additions. NXP Semiconductors does not give any representations or warranties as to the accuracy or completeness of information included herein and shall have no liability for the consequences of use of such information.

Short data sheet — A short data sheet is an extract from a full data sheet with the same product type number(s) and title. A short data sheet is intended for quick reference only and should not be relied upon to contain detailed and full information. For detailed and full information see the relevant full data sheet, which is available on request via the local NXP Semiconductors sales office. In case of any inconsistency or conflict with the short data sheet, the full data sheet shall prevail.

Product specification — The information and data provided in a Product data sheet shall define the specification of the product as agreed between NXP Semiconductors and its customer, unless NXP Semiconductors and customer have explicitly agreed otherwise in writing. In no event however, shall an agreement be valid in which the NXP Semiconductors product is deemed to offer functions and qualities beyond those described in the Product data sheet.

15.3 Disclaimers

Limited warranty and liability — Information in this document is believed to be accurate and reliable. However, NXP Semiconductors does not give any representations or warranties, expressed or implied, as to the accuracy or completeness of such information and shall have no liability for the consequences of use of such information.

In no event shall NXP Semiconductors be liable for any indirect, incidental, punitive, special or consequential damages (including - without limitation - lost profits, lost savings, business interruption, costs related to the removal or replacement of any products or rework charges) whether or not such damages are based on tort (including negligence), warranty, breach of contract or any other legal theory.

Notwithstanding any damages that customer might incur for any reason whatsoever, NXP Semiconductors' aggregate and cumulative liability towards customer for the products described herein shall be limited in accordance with the *Terms and conditions of commercial sale* of NXP Semiconductors.

Right to make changes — NXP Semiconductors reserves the right to make changes to information published in this document, including without limitation specifications and product descriptions, at any time and without notice. This document supersedes and replaces all information supplied prior to the publication hereof.

Suitability for use — NXP Semiconductors products are not designed, authorized or warranted to be suitable for use in life support, life-critical or safety-critical systems or equipment, nor in applications where failure or

malfunction of an NXP Semiconductors product can reasonably be expected to result in personal injury, death or severe property or environmental damage. NXP Semiconductors accepts no liability for inclusion and/or use of NXP Semiconductors products in such equipment or applications and therefore such inclusion and/or use is at the customer's own risk.

Applications — Applications that are described herein for any of these products are for illustrative purposes only. NXP Semiconductors makes no representation or warranty that such applications will be suitable for the specified use without further testing or modification.

Customers are responsible for the design and operation of their applications and products using NXP Semiconductors products, and NXP Semiconductors accepts no liability for any assistance with applications or customer product design. It is customer's sole responsibility to determine whether the NXP Semiconductors product is suitable and fit for the customer's applications and products planned, as well as for the planned application and use of customer's third party customer(s). Customers should provide appropriate design and operating safeguards to minimize the risks associated with their applications and products.

NXP Semiconductors does not accept any liability related to any default, damage, costs or problem which is based on any weakness or default in the customer's applications or products, or the application or use by customer's third party customer(s). Customer is responsible for doing all necessary testing for the customer's applications and products using NXP Semiconductors products in order to avoid a default of the applications and the products or of the application or use by customer's third party customer(s). NXP does not accept any liability in this respect.

Limiting values — Stress above one or more limiting values (as defined in the Absolute Maximum Ratings System of IEC 60134) will cause permanent damage to the device. Limiting values are stress ratings only and (proper) operation of the device at these or any other conditions above those given in the Recommended operating conditions section (if present) or the Characteristics sections of this document is not warranted. Constant or repeated exposure to limiting values will permanently and irreversibly affect the quality and reliability of the device.

Terms and conditions of commercial sale — NXP Semiconductors products are sold subject to the general terms and conditions of commercial sale, as published at <http://www.nxp.com/profile/terms>, unless otherwise agreed in a valid written individual agreement. In case an individual agreement is concluded only the terms and conditions of the respective agreement shall apply. NXP Semiconductors hereby expressly objects to applying the customer's general terms and conditions with regard to the purchase of NXP Semiconductors products by customer.

No offer to sell or license — Nothing in this document may be interpreted or construed as an offer to sell products that is open for acceptance or the grant, conveyance or implication of any license under any copyrights, patents or other industrial or intellectual property rights.

Export control — This document as well as the item(s) described herein may be subject to export control regulations. Export might require a prior authorization from competent authorities.

Non-automotive qualified products — Unless this data sheet expressly states that this specific NXP Semiconductors product is automotive qualified, the product is not suitable for automotive use. It is neither qualified nor tested in accordance with automotive testing or application requirements. NXP Semiconductors accepts no liability for inclusion and/or use of non-automotive qualified products in automotive equipment or applications.

In the event that customer uses the product for design-in and use in automotive applications to automotive specifications and standards, customer (a) shall use the product without NXP Semiconductors' warranty of the product for such automotive applications, use and specifications, and (b) whenever customer uses the product for automotive applications beyond

NXP Semiconductors' specifications such use shall be solely at customer's own risk, and (c) customer fully indemnifies NXP Semiconductors for any liability, damages or failed product claims resulting from customer design and use of the product for automotive applications beyond NXP Semiconductors' standard warranty and NXP Semiconductors' product specifications.

15.4 Trademarks

Notice: All referenced brands, product names, service names and trademarks are the property of their respective owners.

16. Contact information

For more information, please visit: <http://www.nxp.com>

For sales office addresses, please send an email to: salesaddresses@nxp.com

17. Contents

1 General description 1

2 Features and benefits 1

3 Ordering information 1

4 Functional diagram 2

5 Pinning information 4

5.1 Pinning 4

5.2 Pin description 4

6 Functional description 5

7 Limiting values 6

8 Recommended operating conditions 6

9 Static characteristics 7

10 Dynamic characteristics 8

11 Waveforms 10

12 Application information 13

13 Package outline 15

14 Revision history 17

15 Legal information 18

15.1 Data sheet status 18

15.2 Definitions 18

15.3 Disclaimers 18

15.4 Trademarks 19

16 Contact information 19

17 Contents 20

Please be aware that important notices concerning this document and the product(s) described herein, have been included in section 'Legal information'.

© NXP B.V. 2011.

All rights reserved.

For more information, please visit: <http://www.nxp.com>



For sales office addresses, please send an email to: salesaddresses@nxp.com

Date of release: 11 November 2011

Document identifier: HEF4511B

Looking for pricing, stock, or lifecycle information?

Click below to explore more details on WIN SOURCE:

-  [View HEF4511BP](#) on WIN SOURCE
-  [NXP / Nexperia](#) Information

Optimize Your Supply Chain with WIN SOURCE Solutions

-  Global Sourcing Solution
-  Obsolete Management
-  Cost Control Management
-  Shortage Management
-  Alternative Solution
-  Excess Inventory Management