

HD3SS3412 4-Channel High-Performance Differential Switch

1 Features

- Compatible With Multiple Interface Standards Operating up to 12 Gbps Including PCI Express Gen III and USB 3.0
- Wide -3dB Differential BW of over 8 GHz
- Excellent Dynamic Characteristics (at 4 GHz)
 - Crosstalk = -35 dB
 - Off Isolation = -19 dB
 - Insertion Loss = -1.5 dB
 - Return Loss = -11 dB
- Bidirectional "MUX/De-MUX" Type Differential Switch
- VDD Operating Range 3.3 V ±10%
- Small 3.5-mm × 9.0-mm, 42-Pin WQFN Package
- Common Industry Standard Pinout
- Supports XAUI and SGMII

2 Applications

- Desktop and Notebook PCs
- Server and Storage Area Networks
- PCI Express Backplanes
- Shared I/O Ports

3 Description

The HD3SS3412 device is a high-speed passive switch capable of switching four differential channels, including applications such as two full PCI Express x1 lanes from one source to one of two target locations in a PC/server application. With its bidirectional capability the HD3SS3412 also supports applications that allow connections between one target and two source devices, such as a shared peripheral between two platforms. The HD3SS3412 has a single control line (SEL pin) which can be used to control the signal path between Port A and either Port B or Port C.

The HD3SS3412 is offered in an industry standard 42-pin WQFN package available in a common footprint shared by several other vendors. The device is specified to operate from a single supply voltage of 3.3 V over the full temperature range of -40°C to 85°C.

Device Information⁽¹⁾

| PART NUMBER | PACKAGE | BODY SIZE (NOM) |
|-------------|-----------|-------------------|
| HD3SS3412 | WQFN (42) | 9.00 mm × 3.50 mm |

(1) For all available packages, see the orderable addendum at the end of the data sheet.

HD3SS3412 Pinout

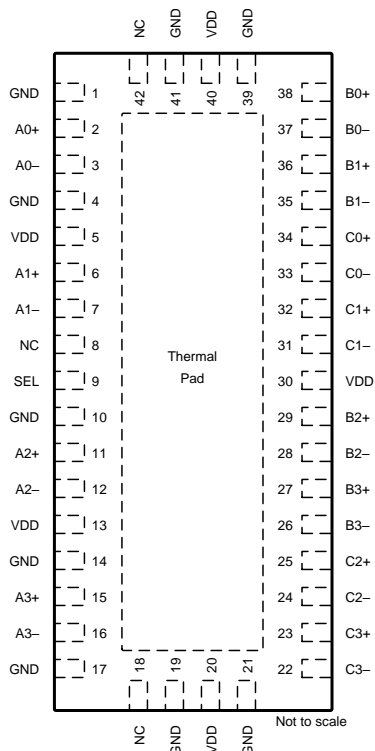

HD3SS3412 Switch Flow Through Routing

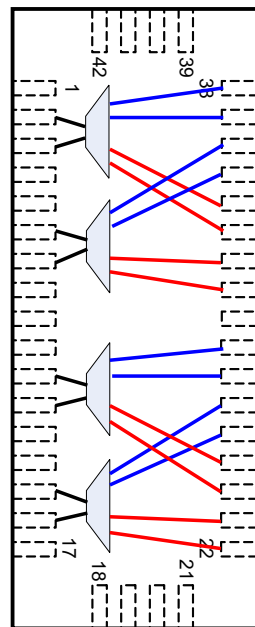

Table of Contents

| | | | |
|--------------------------------------------------|-----------|------------------------------------------------------------------|-----------|
| 1 Features | 1 | 9.2 Functional Block Diagram | 13 |
| 2 Applications | 1 | 9.3 Feature Description | 14 |
| 3 Description | 1 | 9.4 Device Functional Modes | 14 |
| 4 Revision History | 2 | 10 Application and Implementation | 15 |
| 5 Description (continued) | 4 | 10.1 Application Information | 15 |
| 6 Pin Configuration and Functions | 5 | 10.2 Typical Application | 16 |
| 7 Specifications | 7 | 11 Power Supply Recommendations | 18 |
| 7.1 Absolute Maximum Ratings | 7 | 12 Layout | 18 |
| 7.2 ESD Ratings | 7 | 12.1 Layout Guidelines | 18 |
| 7.3 Recommended Operating Conditions | 7 | 12.2 Layout Example | 18 |
| 7.4 Thermal Information | 7 | 13 Device and Documentation Support | 19 |
| 7.5 Electrical Characteristics | 8 | 13.1 Receiving Notification of Documentation Updates | 19 |
| 7.6 Dissipation Ratings | 8 | 13.2 Community Resources | 19 |
| 7.7 Typical Characteristics | 10 | 13.3 Trademarks | 19 |
| 8 Parameter Measurement Information | 11 | 13.4 Electrostatic Discharge Caution | 19 |
| 9 Detailed Description | 13 | 13.5 Glossary | 19 |
| 9.1 Overview | 13 | 14 Mechanical, Packaging, and Orderable Information | 19 |

4 Revision History

NOTE: Page numbers for previous revisions may differ from page numbers in the current version.

| Changes from Revision E (January 2015) to Revision F | Page |
|-------------------------------------------------------------------------------------------------------------------------------------------|-------------|
| • Changed temperature range to –40°C to 85°C from 0°C to 70°C. | 1 |
| • Changed T _A To: –40°C MIN and 85°C MAX From: 0°C MIN and 70°C MAX in the <i>Recommended Operating Conditions</i> table | 7 |
| • Changed the P _D values From: MIN = 15.5, MAX = 21.6 To: MIN = 2.8, MAX = 4.4 in the <i>Dissipation Ratings</i> table | 8 |

| Changes from Revision D (December 2015) to Revision E | Page |
|-------------------------------------------------------------------------------------------------------------------------------------------------------------------------|-------------|
| • Changed "over the full industrial temperature range of –40°C to 70°C" To: "over the commercial temperature range of 0°C to 70°C" in the <i>Overview</i> section | 13 |

| Changes from Revision C (July 2015) to Revision D | Page |
|------------------------------------------------------------------------------------------------------------------------------------------------------------|-------------|
| • Changed "full industrial temperature range of –40°C to 85°C" To: "full industrial temperature range of 0°C to 70°C" in the <i>Overview</i> section | 13 |

| Changes from Revision B (November 2013) to Revision C | Page |
|------------------------------------------------------------------------------------------------------------------------------------------------------------------------------------------------------------------------------------------------------------------------------------------------------------------------------------------------------------------------------------------------------|-------------|
| • Added <i>Pin Configuration and Functions</i> section, <i>ESD Ratings</i> table, <i>Feature Description</i> section, <i>Device Functional Modes</i> , <i>Application and Implementation</i> section, <i>Power Supply Recommendations</i> section, <i>Layout</i> section, <i>Device and Documentation Support</i> section, and <i>Mechanical, Packaging, and Orderable Information</i> section | 1 |
| • Removed <i>Ordering Information</i> table | 1 |

| Changes from Revision A (February 2012) to Revision B | Page |
|----------------------------------------------------------------------------------------------------------------------------|-------------|
| • Added additional feature: bidirectional "MUX/de-MUX" type differential switch | 1 |
| • Added that the device supports XAUI and SGMII | 1 |
| • Changed temperature range from –40°C to 85°C to 0°C to 70°C and deleted "industrial" in <i>Description</i> section. | 1 |

| | |
|---------------------------------------------------------------------------------------------------------------------------------------------------------|----|
| • Changed pin description of NC From: Electrically not connected. To: Electrically not connected. May connect to VDD or GND, or leave unconnected | 6 |
| • Added the <i>Application Information</i> section | 15 |

Changes from Original (January 2012) to Revision A
Page

| | |
|-------------------------------------------------------------------------------------------------------------------------------------------------------------------------------------------------|----|
| • Changed Differential BW Feature bullet from "7.5GHZ" to "8GHZ"..... | 1 |
| • Changed Dynamic Characteristics Feature sub-bullet from "Isolation" to "Off Isolation" | 1 |
| • Changed Dynamic Characteristics sub-bullet Return Loss from "-9 dB" to "-11 dB" | 1 |
| • Deleted Dynamic Characteristics sub-bullet "Max Intra-Pair (Bit-Bit) Skew" | 1 |
| • Changed ESD, Human body model, MAX voltage from "±2000" to "±4,000" in Absolute Maximum Ratings table | 7 |
| • Changed I _{LK} spec (Diff I/O pins) MAX value from "4 µA" to "130 µA" and added [Ports B and C] and [Port A] to Conditions statements. | 8 |
| • Changed t _{PD} spec MAX delay from "50" ps to "85" ps in Device Parameters table..... | 8 |
| • Changed SEL-to-switch T _{on} and T _{off} spec TYP values from "175" ns to "70" ns; in the Device Parameters table..... | 8 |
| • Changed T _{SKEW_Inter} and T _{SKEW_Intra} spec MAX values from "5 ps" and "4 ps" respectively, to "20 ps" and "8 ps" respectively, in Electrical Characteristics table..... | 8 |
| • Changed R _L spec TYP value from "-25" and "-9" dB to "-28" and "-11" dB for f=0.3 MHz and f=4000 MHz, respectively, in Electrical Characteristics table. | 8 |
| • Changed O _{IRR} spec TYP value from "-70" to "-75" dB for f=0.3 MHz, in Electrical Characteristics table. | 8 |
| • Changed BW spec TYP value from "7.5" GHz to "8" GHz in Electrical Characteristics table. | 8 |
| • Changed graphic image for Figure 3 | 10 |
| • Changed graphic image for Figure 4 | 10 |

5 Description (continued)

The HD3SS3412 is a generic 4-CH high-speed MUX/de-MUX type of switch that can be used for routing high-speed signals between two different locations on a circuit board. Although it was designed specifically to address PCI Express Gen III applications, the HD3SS3412 will also support several other high-speed data protocols with a differential amplitude of <math><1800\text{ mVpp}</math> and a common-mode voltage of <math><2\text{ V}</math>, as with USB 3.0 and DisplayPort 1.2. The device's one select input (SEL) pin can easily be controlled by an available GPIO pin within a system or from a microcontroller.

6 Pin Configuration and Functions

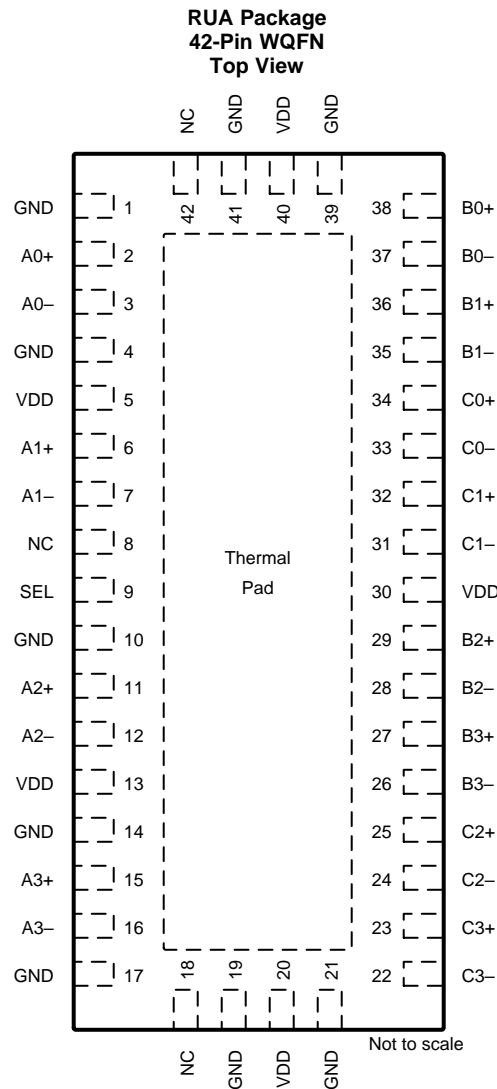

Pin Functions

| PIN | | I/O | DESCRIPTION |
|----------------------|-----|-----|-----------------------------------------------|
| NAME | NO. | | |
| SWITCH PORT A | | | |
| A0+ | 2 | I/O | Port A, Channel 0, High-Speed Positive Signal |
| A0- | 3 | I/O | Port A, Channel 0, High-Speed Negative Signal |
| A1+ | 6 | I/O | Port A, Channel 1, High-Speed Positive Signal |
| A1- | 7 | I/O | Port A, Channel 1, High-Speed Negative Signal |
| A2+ | 11 | I/O | Port A, Channel 2, High-Speed Positive Signal |
| A2- | 12 | I/O | Port A, Channel 2, High-Speed Negative Signal |
| A3+ | 15 | I/O | Port A, Channel 3, High-Speed Positive Signal |
| A3- | 16 | I/O | Port A, Channel 3, High-Speed Negative Signal |
| SWITCH PORT B | | | |
| B0+ | 38 | I/O | Port B, Channel 0, High-Speed Positive Signal |
| B0- | 37 | I/O | Port B, Channel 0, High-Speed Negative Signal |

Pin Functions (continued)

| PIN | | I/O | DESCRIPTION |
|----------------------------------------|-----|--------|-----------------------------------------------------------------------------------|
| NAME | NO. | | |
| B1+ | 36 | I/O | Port B, Channel 1, High-Speed Positive Signal |
| B1– | 35 | I/O | Port B, Channel 1, High-Speed Negative Signal |
| B2+ | 29 | I/O | Port B, Channel 2, High-Speed Positive Signal |
| B2– | 28 | I/O | Port B, Channel 2, High-Speed Negative Signal |
| B3+ | 27 | I/O | Port B, Channel 3, High-Speed Positive Signal |
| B3– | 26 | I/O | Port B, Channel 3, High-Speed Negative Signal |
| SWITCH PORT C | | | |
| C0+ | 34 | I/O | Port C, Channel 0, High-Speed Positive Signal |
| C0– | 33 | I/O | Port C, Channel 0, High-Speed Negative Signal |
| C1+ | 32 | I/O | Port C, Channel 1, High-Speed Positive Signal |
| C1– | 31 | I/O | Port C, Channel 1, High-Speed Negative Signal |
| C2+ | 25 | I/O | Port C, Channel 2, High-Speed Positive Signal |
| C2– | 24 | I/O | Port C, Channel 2, High-Speed Negative Signal |
| C3+ | 23 | I/O | Port C, Channel 3, High-Speed Positive Signal |
| C3– | 22 | I/O | Port C, Channel 3, High-Speed Negative Signal |
| CONTROL, SUPPLY, AND NO CONNECT | | | |
| NC | 8 | — | Electrically not connected. May connect to VDD or GND, or leave unconnected. |
| | 18 | | |
| | 42 | | |
| GND | 1 | Supply | Negative power supply voltage |
| | 4 | | |
| | 10 | | |
| | 14 | | |
| | 17 | | |
| | 19 | | |
| | 21 | | |
| | 39 | | |
| | 41 | | |
| Center Pad | | | |
| SEL | 9 | I | Select between port B or port C. Internally tied to GND through a 100-kΩ resistor |
| VDD | 5 | Supply | Positive power supply voltage |
| | 13 | | |
| | 20 | | |
| | 30 | | |
| | 40 | | |

7 Specifications

7.1 Absolute Maximum Ratings

Over operating free-air temperature range (unless otherwise noted)⁽¹⁾⁽²⁾

| | | MIN | MAX | UNIT |
|--------------------------------|-----------------------------------------|------|----------------|------|
| Supply voltage (V_{DD}) | Absolute minimum/maximum supply voltage | -0.5 | 4 | V |
| Voltage | Differential I/O | -0.5 | 4 | V |
| | Control pin (SEL) | -0.5 | $V_{DD} + 0.5$ | |
| Storage temperature, T_{stg} | | -65 | 150 | °C |

- (1) Stresses beyond those listed under *Absolute Maximum Ratings* may cause permanent damage to the device. These are stress ratings only and functional operation of the device at these or any conditions beyond those indicated under *Recommended Operating Conditions* is not implied. Exposure to absolute-maximum-rated conditions for extended periods may affect device reliability.
- (2) All voltage values, except differential voltages, are with respect to network ground terminal.

7.2 ESD Ratings

| | | VALUE | UNIT |
|-------------------------------------|--------------------------------------------------------------------------------|-------|------|
| $V_{(ESD)}$ Electrostatic discharge | Human-body model (HBM), per ANSI/ESDA/JEDEC JS-001 ⁽¹⁾ | ±4000 | V |
| | Charged-device model (CDM), per JEDEC specification JESD22-C101 ⁽²⁾ | ±1500 | |

- (1) JEDEC document JEP155 states that 500-V HBM allows safe manufacturing with a standard ESD control process.
- (2) JEDEC document JEP157 states that 250-V CDM allows safe manufacturing with a standard ESD control process.

7.3 Recommended Operating Conditions

Typical values for all parameters are at $V_{DD} = 3.3$ V and $T_A = 25^\circ\text{C}$. (Temperature limits are specified by design)

| | | MIN | NOM | MAX | UNIT | |
|-----------------|------------------------------------------|--------------------------------|-----|----------|------|----|
| V_{DD} | Supply voltage | 3 | 3.3 | 3.6 | V | |
| V_{IH} | Input high voltage (SEL pin) | 2 | | V_{DD} | V | |
| V_{IL} | Input low voltage (SEL pin) | -0.1 | | 0.8 | V | |
| V_{I/O_Diff} | Differential voltage (differential pins) | Switch I/O diff voltage | | 1.8 | VPP | |
| V_{I/O_CM} | Common voltage (differential pins) | Switch I/O common-mode voltage | | 2 | V | |
| T_A | Operating free-air temperature | Ambient temperature | | -40 | 85 | °C |

7.4 Thermal Information

| THERMAL METRIC ⁽¹⁾ | | HD3SS3412 | UNIT |
|-------------------------------|----------------------------------------------|------------|------|
| | | RUA (WQFN) | |
| | | 42 PINS | |
| $R_{\theta JA}$ | Junction-to-ambient thermal resistance | 53.8 | °C/W |
| $R_{\theta JC(top)}$ | Junction-to-case (top) thermal resistance | 38.2 | °C/W |
| $R_{\theta JB}$ | Junction-to-board thermal resistance | 21.9 | °C/W |
| Ψ_{JT} | Junction-to-top characterization parameter | 27.4 | °C/W |
| Ψ_{JB} | Junction-to-board characterization parameter | 5.6 | °C/W |
| $R_{\theta JC(bot)}$ | Junction-to-case (bottom) thermal resistance | 27.3 | °C/W |

- (1) For more information about traditional and new thermal metrics, see the [Semiconductor and IC Package Thermal Metrics](#) application report.

7.5 Electrical Characteristics

Over operating free-air temperature range (unless otherwise noted)

| PARAMETER | | TEST CONDITIONS | MIN | TYP | MAX | UNIT |
|--------------------------|-----------------------------------------------------------------------------------------------------------|-------------------------------------------------------------------------------------------------------------------|-----|------|------|---------------|
| DEVICE PARAMETERS | | | | | | |
| I_{IH} | Input High Voltage (SEL) | $V_{DD} = 3.6\text{ V}; V_{IN} = V_{DD}$ | | | 95 | μA |
| I_{IL} | Input Low Voltage (SEL) | $V_{DD} = 3.6\text{ V}; V_{IN} = \text{GND}$ | | | 1 | μA |
| I_{LK} | Leakage Current (Differential I/O pins) | $V_{DD} = 3.6\text{ V}; V_{IN} = 0\text{ V}; V_{OUT} = 2\text{ V}$ (I_{LK} On OPEN outputs) [Ports B and C] | | | 130 | μA |
| | | $V_{DD} = 3.6\text{ V}; V_{IN} = 2\text{ V}; V_{OUT} = 0\text{ V}$ (I_{LK} On OPEN outputs) [Port A] | | | 4 | |
| I_{DD} | Supply Current | $V_{DD} = 3.6\text{ V}; \text{SEL} = V_{DD}/\text{GND}; \text{Outputs Floating}$ | | 4.7 | 6 | mA |
| C_{ON} | Outputs ON Capacitance | $V_{IN} = 0\text{ V}; \text{Outputs Open}; \text{Switch ON}$ | | 1.5 | | pF |
| C_{OFF} | Outputs OFF Capacitance | $V_{IN} = 0\text{ V}; \text{Outputs Open}, \text{Switch OFF}$ | | 1 | | pF |
| R_{ON} | Output ON resistance | $V_{DD} = 3.3\text{ V}; V_{CM} = 0.5\text{ V to } 1.5\text{ V}; I_O = -8\text{ mA}$ | | 5 | 8 | Ω |
| ΔR_{ON} | ON-resistance match between channels | $V_{DD} = 3.3\text{ V}; -0.35\text{ V} \leq V_{IN} \leq 1.2\text{ V}; I_O = -8\text{ mA}$ | | | 2 | Ω |
| | ON-resistance match between pairs of the same channel | $V_{DD} = 3.3\text{ V}; -0.35\text{ V} \leq V_{IN} \leq 1.2\text{ V}; I_O = -8\text{ mA}$ | | | 0.7 | Ω |
| R_{FLAT_ON} | ON-resistance flatness ($R_{ON(MAX)} - R_{ON(MAIN)}$) | $V_{DD} = 3.3\text{ V}; -0.35\text{ V} \leq V_{IN} \leq 1.2\text{ V}$ | | | 1.15 | Ω |
| t_{PD} | Switch propagation delay | R_{sc} and $R_{LOAD} = 50\ \Omega$ | | | 85 | ps |
| | SEL-to-switch T_{ON} | R_{sc} and $R_{LOAD} = 50\ \Omega$ | | 70 | 250 | ns |
| | SEL-to-switch T_{OFF} | | | 70 | 250 | |
| T_{SKEW_Inter} | Inter-pair output skew (CH-CH) | R_{sc} and $R_{LOAD} = 50\ \Omega$ | | | 20 | ps |
| T_{SKEW_Intra} | Intra-pair output skew (bit-bit) | R_{sc} and $R_{LOAD} = 50\ \Omega$ | | | 8 | ps |
| R_L | Differential return loss ($V_{CM} = 0\text{ V}$) Also see Typical Characteristics | $f = 0.3\text{ MHz}$ | | -28 | | dB |
| | | $f = 2500\text{ MHz}$ | | -12 | | |
| | | $f = 4000\text{ MHz}$ | | -11 | | |
| X_{TALK} | Differential Crosstalk ($V_{CM} = 0\text{ V}$) Also see Typical Characteristics | $f = 0.3\text{ MHz}$ | | -90 | | dB |
| | | $f = 2500\text{ MHz}$ | | -39 | | |
| | | $f = 4000\text{ MHz}$ | | -35 | | |
| O_{IRR} | Differential Off-Isolation ($V_{CM} = 0\text{ V}$) Also see Typical Characteristics | $f = 0.3\text{ MHz}$ | | -75 | | dB |
| | | $f = 2500\text{ MHz}$ | | -22 | | |
| | | $f = 4000\text{ MHz}$ | | -19 | | |
| I_L | Differential Insertion Loss ($V_{CM} = 0\text{ V}$) Also see Typical Characteristics | $f = 0.3\text{ MHz}$ | | -0.5 | | dB |
| | | $f = 2500\text{ MHz}$ | | -1.1 | | |
| | | $f = 4000\text{ MHz}$ | | -1.5 | | |
| BW | Bandwidth | At -3 dB | | 8 | | GHz |

7.6 Dissipation Ratings

| | | MIN | MAX | UNIT |
|-------|-------------------|-----|-----|------|
| P_D | Power Dissipation | 2.8 | 4.4 | mW |

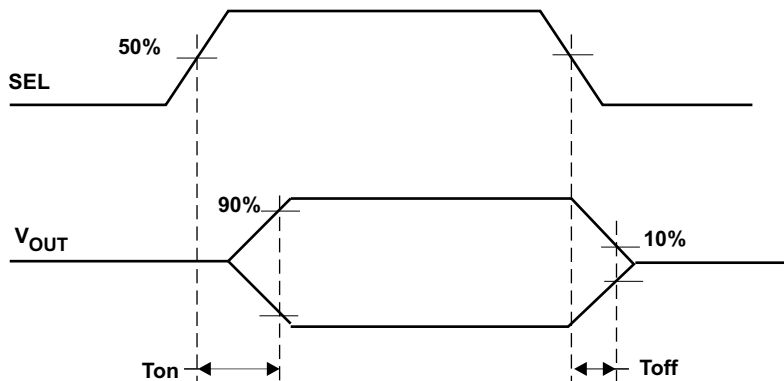
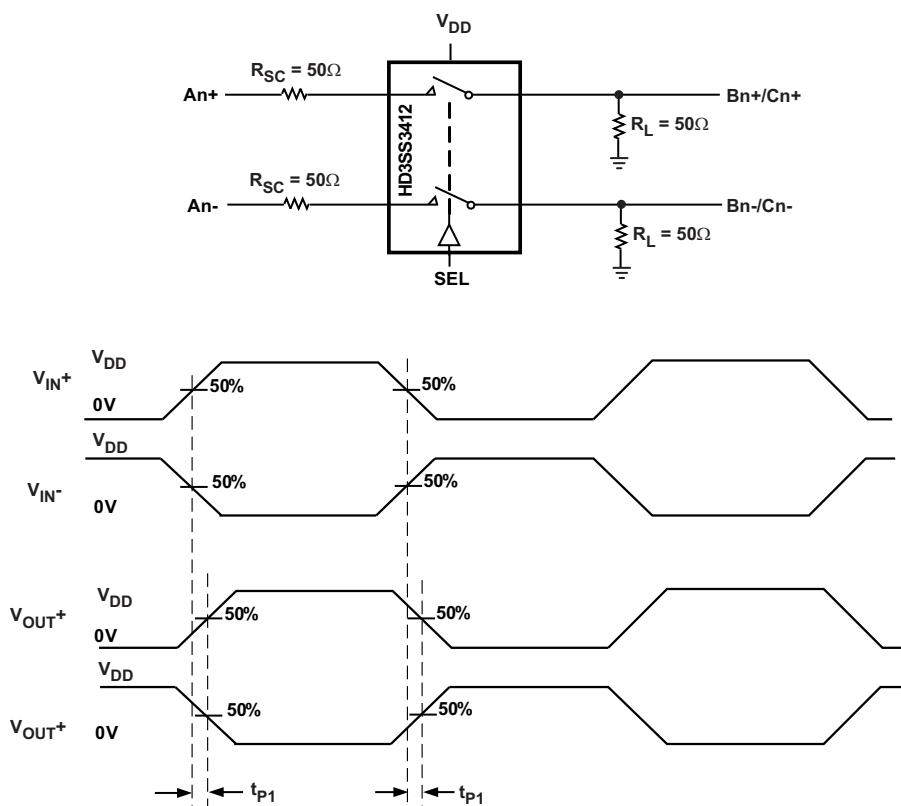

Figure 1. Switch ON and OFF Timing Diagram



$T_{\text{SKEWInter}}$ = Difference between t_{PD} for any two pairs of outputs

$T_{\text{SKEWIntra}}$ = Difference between t_{P1} and t_{P2} of same pair

Figure 2. Propagation Delay Timing Diagram and Test Setup

7.7 Typical Characteristics

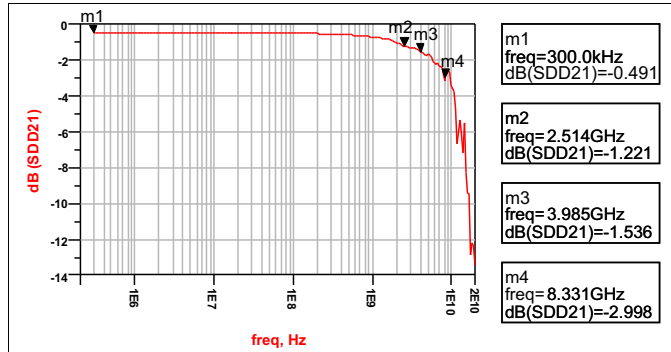
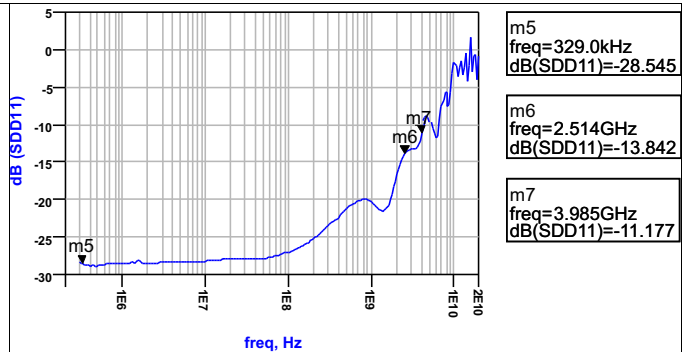
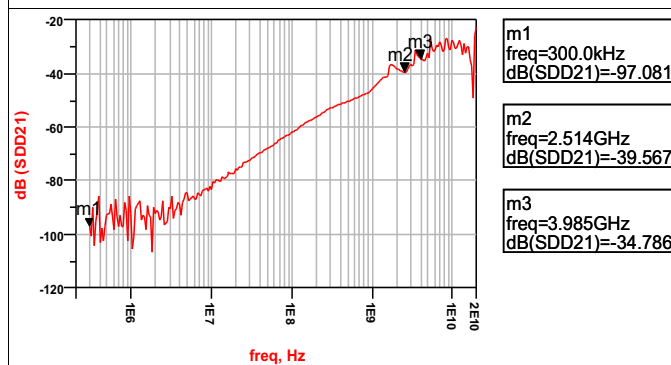
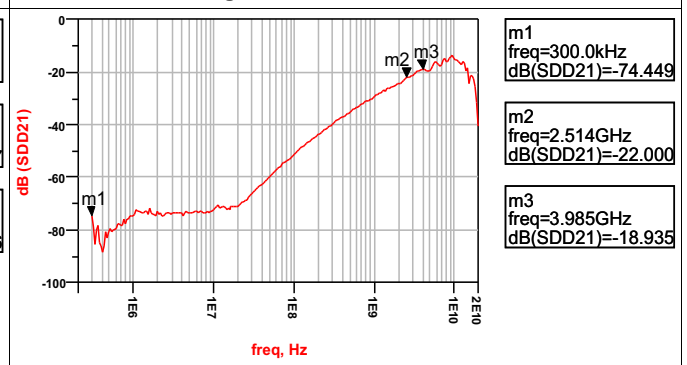
Figure 3. Differential Insertion Loss

Figure 4. Differential Return Loss

Figure 5. Differential Crosstalk

Figure 6. Differential Off Isolation

8 Parameter Measurement Information

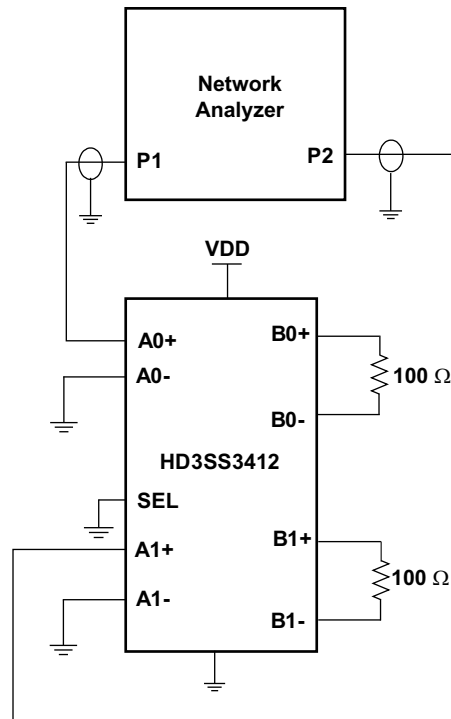

Figure 7. Cross Talk Measurement Setup

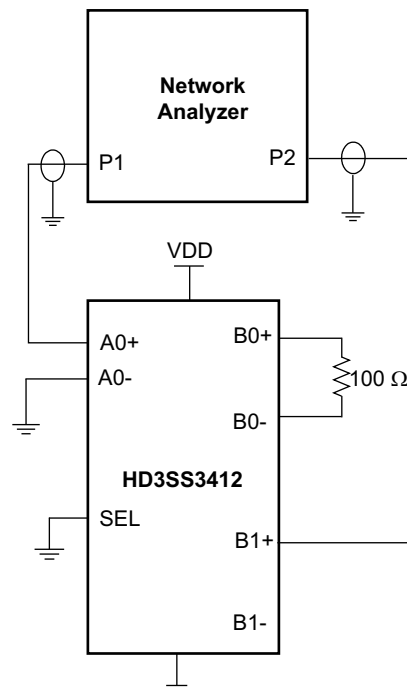

Figure 8. Off Isolation Measurement Setup

Parameter Measurement Information (continued)

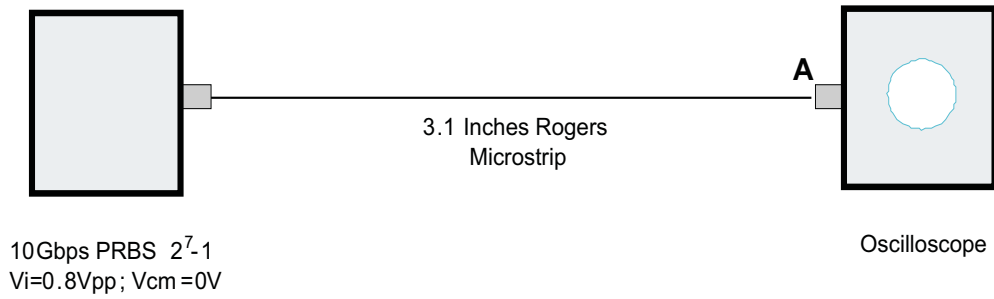

Figure 9. Source Eye Diagram Test Setup

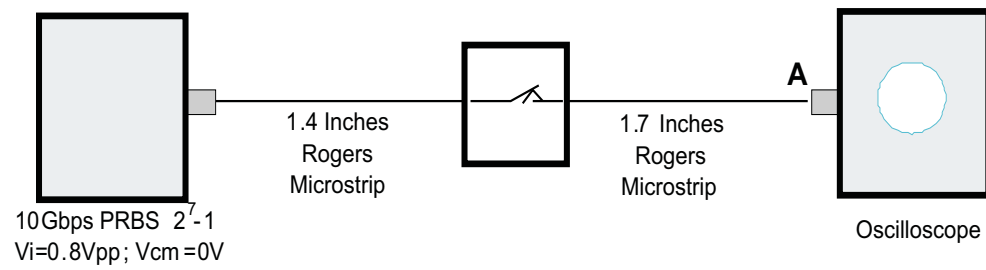

Figure 10. Output Eye Diagram Test Setup

9 Detailed Description

9.1 Overview

The HD3SS3412 is a high-speed passive switch offered in an industry standard 42-pin WQFN package available in a common footprint shared by several other vendors. The device is specified to operate from a single supply voltage of 3.3 V over the commercial temperature range of 0°C to 70°C. The HD3SS3412 is a generic 4-CH high-speed mux/demux type of switch that can be used for routing high-speed PCI signals between two different locations on a circuit board. Although it was designed specifically to address PCI Express Gen III applications, the HD3SS3412 will also support several other high-speed data protocols with a differential amplitude of < 1800 mVpp and a common-mode voltage of < 2.0 V, as with USB 3.0 and DisplayPort 1.2. The device's one select input (SEL) pin can easily be controlled by an available GPIO pin within a system or from a microcontroller.

9.2 Functional Block Diagram

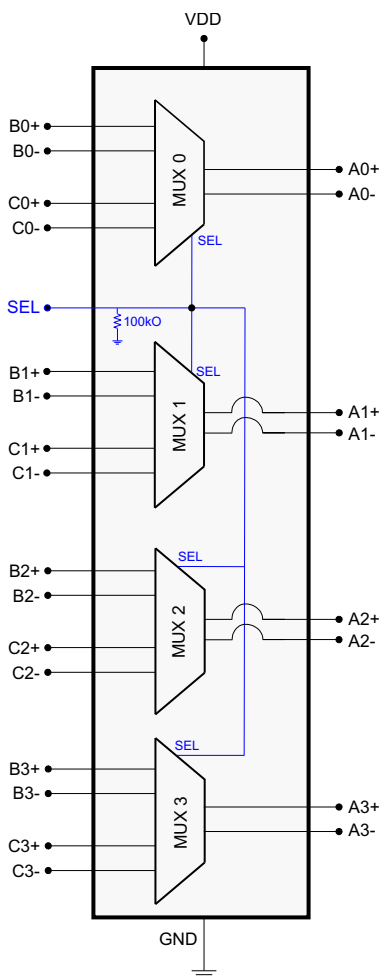

9.3 Feature Description

The HD3SS3412 has a single control line (SEL Pin) which can be used to control the signal path between Port A and either Port B or Port C. The one select input (SEL) pin of the device can easily be controlled by an available GPIO pin within a system or from a microcontroller. The input signal is selected using the SEL pin.

Table 1. Mux Pin Connections⁽¹⁾

| PORT A CHANNEL | PORT B OR PORT C CHANNEL CONNECTED TO PORT A CHANNEL | |
|----------------|---------------------------------------------------------|---------|
| | SEL = L | SEL = H |
| A0+ | B0+ | C0+ |
| A0– | B0– | C0– |
| A1+ | B1+ | C1+ |
| A1– | B1– | C1– |
| A2+ | B2+ | C2+ |
| A2– | B2– | C2– |
| A3+ | B3+ | C3+ |
| A3– | B3– | C3– |

(1) The HD3SS3412 can tolerate polarity inversions for all differential signals on Ports A, B, and C. Take care to ensure the same polarity is maintained on Port A versus Port B/C.

9.4 Device Functional Modes

[Table 2](#) lists the functional modes for the HD3SS3412.

Table 2. HD3SS3412 Control Logic

| CONTROL PIN (SEL) | PORT A TO PORT B CONNECTION STATUS | PORT A TO PORT C CONNECTION STATUS |
|-------------------|---------------------------------------|---------------------------------------|
| L (Default State) | Connected | Disconnected |
| H | Disconnected | Connected |

10 Application and Implementation

NOTE

Information in the following applications sections is not part of the TI component specification, and TI does not warrant its accuracy or completeness. TI's customers are responsible for determining suitability of components for their purposes. Customers should validate and test their design implementation to confirm system functionality.

10.1 Application Information

10.1.1 AC Coupling Caps

Many interfaces require AC coupling between the transmitter and receiver. The 0402 capacitors are the preferred option to provide AC coupling, and the 0603 size capacitors also work. The 0805 size capacitors and C-packs should be avoided. When placing AC coupling capacitors symmetric placement is best. A capacitor value of 0.1 μF is best and the value should be match for the \pm signal pair. The placement should be along the TX pairs on the system board, which are usually routed on the top layer of the board.

There are several placement options for the AC coupling capacitors. Because the switch requires a bias voltage, the capacitors must only be placed on one side of the switch. If they are placed on both sides of the switch, a biasing voltage should be provided. A few placement options are shown below. In Figure 11, the coupling capacitors are placed between the switch and endpoint. In this situation, the switch is biased by the system/host controller.

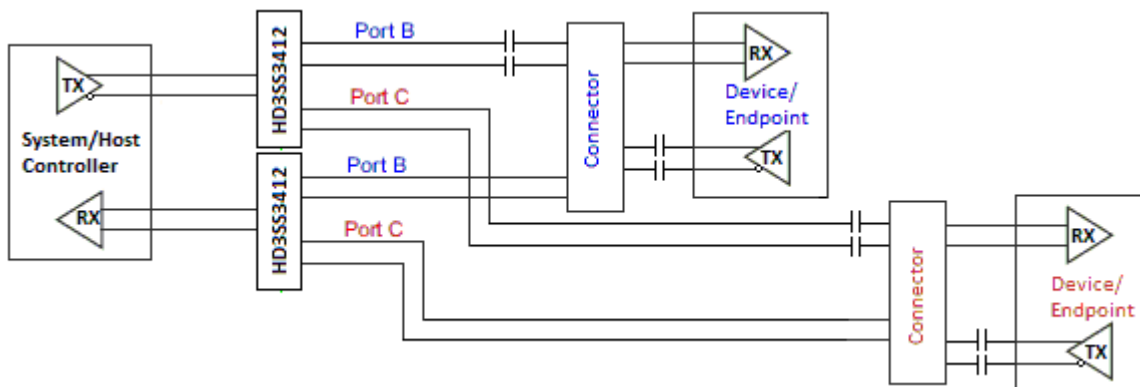

Figure 11. AC Coupling Capacitors Between Switch Tx and Endpoint Tx

In Figure 12, the coupling capacitors are placed on the host transmit pair and endpoint transmit pair. In this situation, the switch on the top is biased by the endpoint and the lower switch is biased by the host controller.

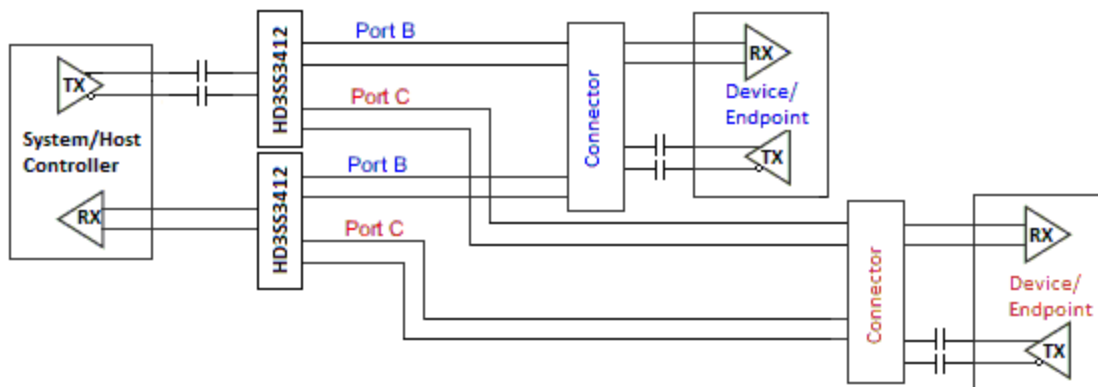

Figure 12. AC Coupling Capacitors on Host Tx and Endpoint Tx

Application Information (continued)

If the common-mode voltage in the system is higher than 2 V, the coupling capacitors are placed on both sides of the switch (shown in Figure 13). A biasing voltage of less than 2 V is required in this case.

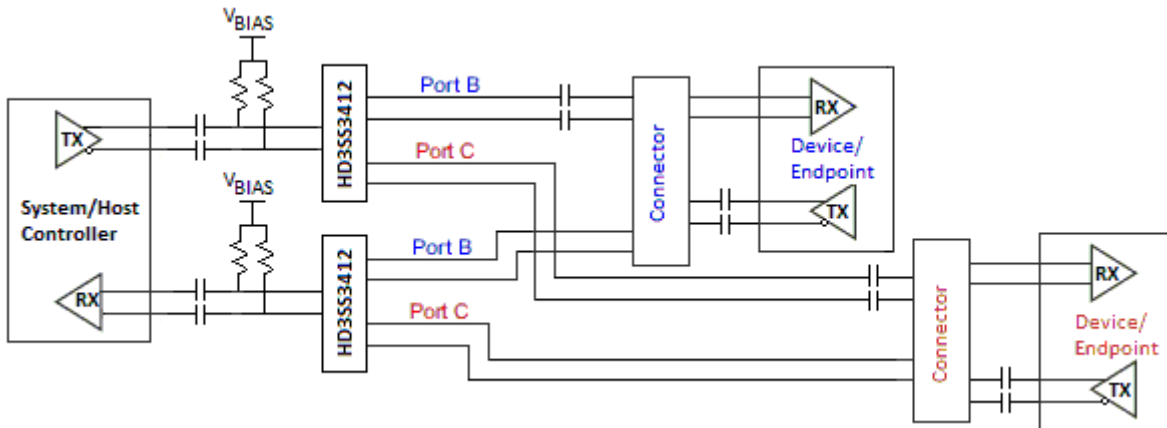

Figure 13. AC Coupling Capacitors on Both Sides of Switch

10.2 Typical Application

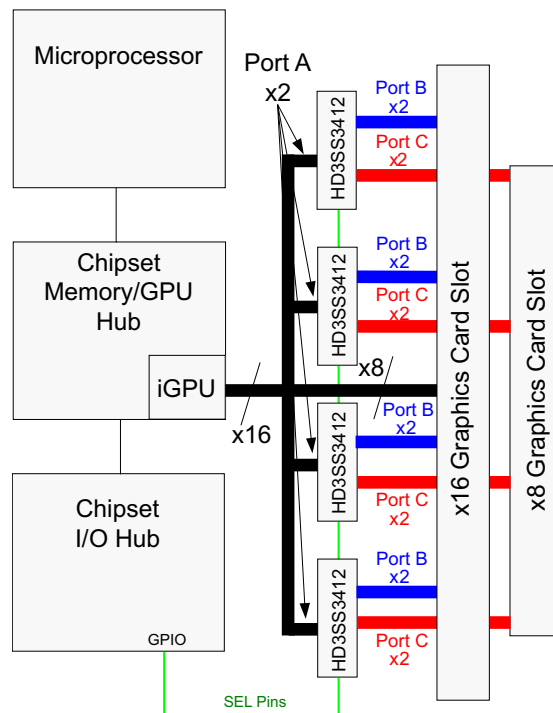

Figure 14. Typical Application Block Diagram

Typical Application (continued)

10.2.1 Design Requirements

Table 3 lists the design parameters of this example.

Table 3. Design Parameters

| DESIGN PARAMETERS | EXAMPLE VALUE |
|-----------------------|-----------------------------------------------------------------------------------------------------------------------------------------|
| Input voltage range | 3.3 V |
| Decoupling capacitors | 0.1 μ F |
| AC capacitors | 75 nF – 200 nF (100 nF shown) USBAA TX p and n lines require AC capacitors. Alternate mode signals may or may not require AC capacitors |

10.2.2 Detailed Design Procedure

- Connect VDD and GND pins to the power and ground planes of the printed circuit board, with 0.1-uF bypass capacitor
- Use +3.3-V TTL/CMOS logic level at SEL
- Use controlled-impedance transmission media for all the differential signals
- Ensure the received complimentary signals are with a differential amplitude of <1800 mVpp and a common-mode voltage of <2 V

10.2.3 Application Curves

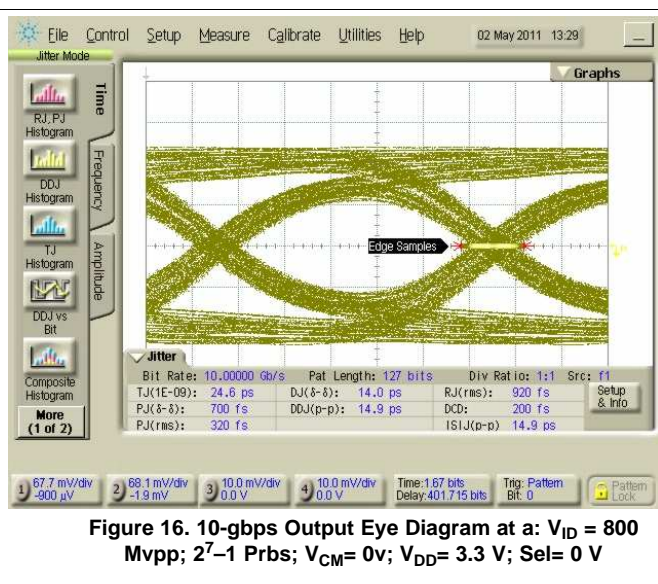
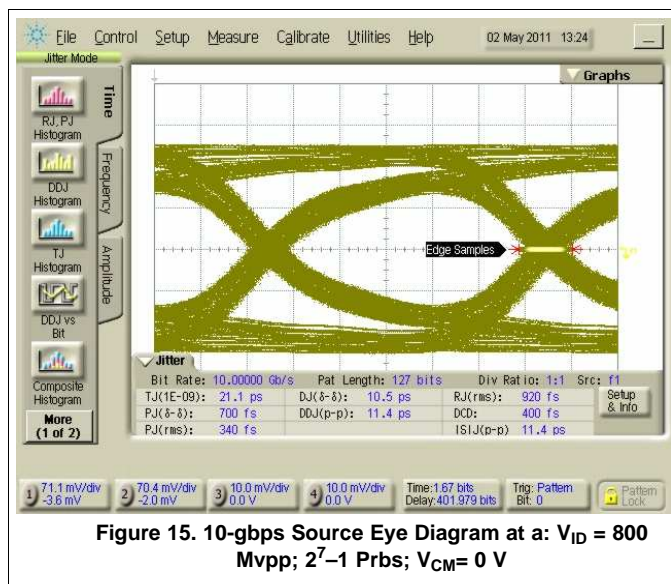

11 Power Supply Recommendations

The HD3SS3412 requires +3.3-V digital power sources. VDD 3.3 supply must have 0.1- μ F bypass capacitors to VSS (ground) in order for proper operation. The recommendation is one capacitor for each power terminal. Place the capacitor as close as possible to the terminal on the device and keep trace length to a minimum. Smaller value capacitors like 0.01- μ F are also recommended on the digital supply terminals.

12 Layout

12.1 Layout Guidelines

- Decoupling caps should be placed next to each power terminal on the HD3SS3412. Take care to minimize the stub length of the trace connecting the capacitor to the power pin.
- Avoid sharing vias between multiple decoupling caps
- Place vias as close as possible to the decoupling cap solder pad
- Widen VDD/GND planes to reduce effect of static and dynamic IR drop
- The VBUS traces/planes must be wide enough to carry maximum of 2-A current

12.2 Layout Example

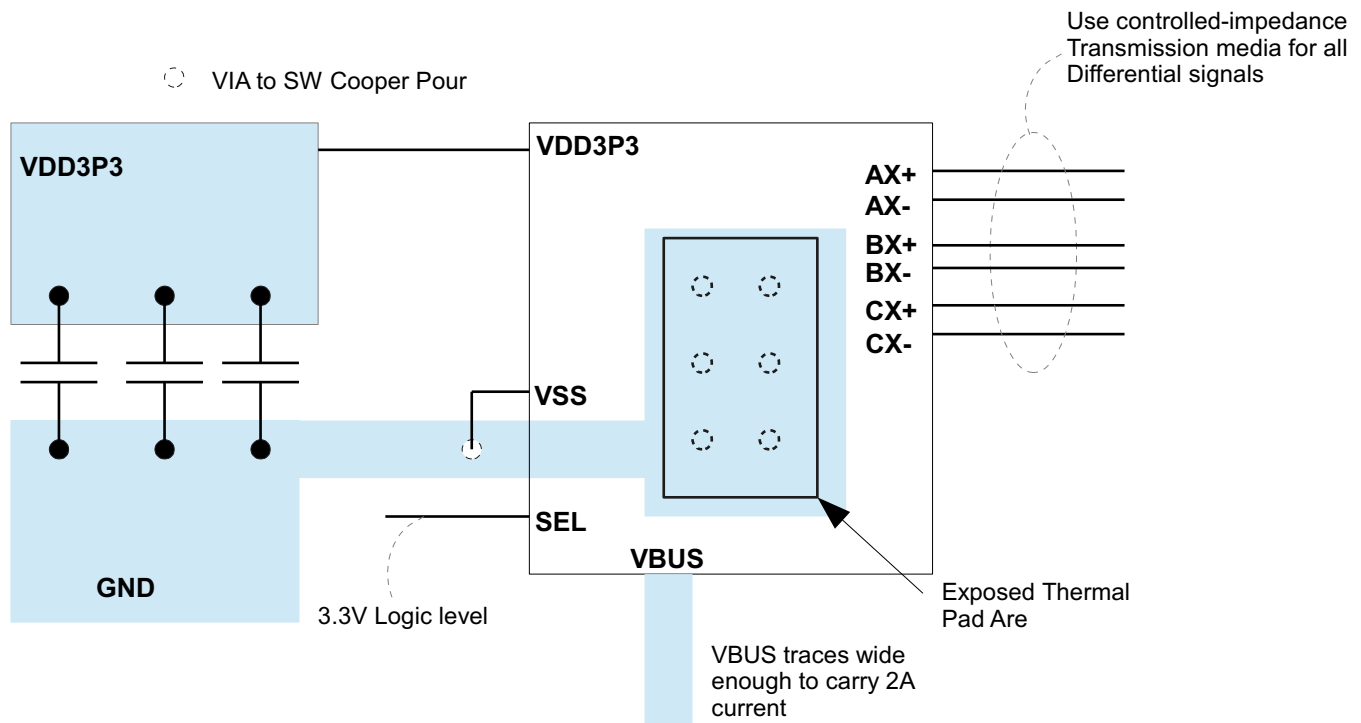

Figure 17. Layout Example

13 Device and Documentation Support

13.1 Receiving Notification of Documentation Updates

To receive notification of documentation updates, navigate to the device product folder on ti.com. In the upper right corner, click on *Alert me* to register and receive a weekly digest of any product information that has changed. For change details, review the revision history included in any revised document.

13.2 Community Resources

The following links connect to TI community resources. Linked contents are provided "AS IS" by the respective contributors. They do not constitute TI specifications and do not necessarily reflect TI's views; see TI's [Terms of Use](#).

TI E2E™ Online Community *TI's Engineer-to-Engineer (E2E) Community*. Created to foster collaboration among engineers. At e2e.ti.com, you can ask questions, share knowledge, explore ideas and help solve problems with fellow engineers.

Design Support *TI's Design Support* Quickly find helpful E2E forums along with design support tools and contact information for technical support.

13.3 Trademarks

E2E is a trademark of Texas Instruments.
All other trademarks are the property of their respective owners.

13.4 Electrostatic Discharge Caution



These devices have limited built-in ESD protection. The leads should be shorted together or the device placed in conductive foam during storage or handling to prevent electrostatic damage to the MOS gates.

13.5 Glossary



[SLYZ022](#) — *TI Glossary*.

This glossary lists and explains terms, acronyms, and definitions.

14 Mechanical, Packaging, and Orderable Information

The following pages include mechanical, packaging, and orderable information. This information is the most current data available for the designated devices. This data is subject to change without notice and revision of this document. For browser-based versions of this data sheet, refer to the left-hand navigation.

PACKAGING INFORMATION

| Orderable Device | Status (1) | Package Type | Package Drawing | Pins | Package Qty | Eco Plan (2) | Lead finish/ Ball material (6) | MSL Peak Temp (3) | Op Temp (°C) | Device Marking (4/5) | Samples |
|------------------|---------------|--------------|-----------------|------|-------------|-----------------|--------------------------------------|----------------------|--------------|-------------------------|-------------------------------------------------------------------------------------|
| HD3SS3412RUAR | ACTIVE | WQFN | RUA | 42 | 3000 | RoHS & Green | NIPDAU | Level-2-260C-1 YEAR | 0 to 70 | HD3SS3412 |  |
| HD3SS3412RUAT | ACTIVE | WQFN | RUA | 42 | 250 | RoHS & Green | NIPDAU | Level-2-260C-1 YEAR | 0 to 70 | XHD3SS3412 HD3SS3412 |  |

(1) The marketing status values are defined as follows:

ACTIVE: Product device recommended for new designs.

LIFEBUY: TI has announced that the device will be discontinued, and a lifetime-buy period is in effect.

NRND: Not recommended for new designs. Device is in production to support existing customers, but TI does not recommend using this part in a new design.

PREVIEW: Device has been announced but is not in production. Samples may or may not be available.

OBSOLETE: TI has discontinued the production of the device.

(2) **RoHS:** TI defines "RoHS" to mean semiconductor products that are compliant with the current EU RoHS requirements for all 10 RoHS substances, including the requirement that RoHS substance do not exceed 0.1% by weight in homogeneous materials. Where designed to be soldered at high temperatures, "RoHS" products are suitable for use in specified lead-free processes. TI may reference these types of products as "Pb-Free".

RoHS Exempt: TI defines "RoHS Exempt" to mean products that contain lead but are compliant with EU RoHS pursuant to a specific EU RoHS exemption.

Green: TI defines "Green" to mean the content of Chlorine (Cl) and Bromine (Br) based flame retardants meet JS709B low halogen requirements of <=1000ppm threshold. Antimony trioxide based flame retardants must also meet the <=1000ppm threshold requirement.

(3) MSL, Peak Temp. - The Moisture Sensitivity Level rating according to the JEDEC industry standard classifications, and peak solder temperature.

(4) There may be additional marking, which relates to the logo, the lot trace code information, or the environmental category on the device.

(5) Multiple Device Markings will be inside parentheses. Only one Device Marking contained in parentheses and separated by a "-" will appear on a device. If a line is indented then it is a continuation of the previous line and the two combined represent the entire Device Marking for that device.

(6) Lead finish/Ball material - Orderable Devices may have multiple material finish options. Finish options are separated by a vertical ruled line. Lead finish/Ball material values may wrap to two lines if the finish value exceeds the maximum column width.

Important Information and Disclaimer:The information provided on this page represents TI's knowledge and belief as of the date that it is provided. TI bases its knowledge and belief on information provided by third parties, and makes no representation or warranty as to the accuracy of such information. Efforts are underway to better integrate information from third parties. TI has taken and continues to take reasonable steps to provide representative and accurate information but may not have conducted destructive testing or chemical analysis on incoming materials and chemicals. TI and TI suppliers consider certain information to be proprietary, and thus CAS numbers and other limited information may not be available for release.

In no event shall TI's liability arising out of such information exceed the total purchase price of the TI part(s) at issue in this document sold by TI to Customer on an annual basis.

TAPE AND REEL INFORMATION

QUADRANT ASSIGNMENTS FOR PIN 1 ORIENTATION IN TAPE

*All dimensions are nominal

| Device | Package Type | Package Drawing | Pins | SPQ | Reel Diameter (mm) | Reel Width W1 (mm) | A0 (mm) | B0 (mm) | K0 (mm) | P1 (mm) | W (mm) | Pin1 Quadrant |
|---------------|--------------|-----------------|------|------|--------------------|--------------------|---------|---------|---------|---------|--------|---------------|
| HD3SS3412RUAR | WQFN | RUA | 42 | 3000 | 330.0 | 16.4 | 3.8 | 9.3 | 1.0 | 8.0 | 16.0 | Q1 |
| HD3SS3412RUAT | WQFN | RUA | 42 | 250 | 180.0 | 16.4 | 3.8 | 9.3 | 1.0 | 8.0 | 16.0 | Q1 |

TAPE AND REEL BOX DIMENSIONS

*All dimensions are nominal

| Device | Package Type | Package Drawing | Pins | SPQ | Length (mm) | Width (mm) | Height (mm) |
|---------------|--------------|-----------------|------|------|-------------|------------|-------------|
| HD3SS3412RUAR | WQFN | RUA | 42 | 3000 | 367.0 | 367.0 | 38.0 |
| HD3SS3412RUAT | WQFN | RUA | 42 | 250 | 210.0 | 185.0 | 35.0 |

GENERIC PACKAGE VIEW

RUA 42

WQFN - 0.8 mm max height

9 x 3.5, 0.5 mm pitch

PLASTIC QUAD FLATPACK - NO LEAD

This image is a representation of the package family, actual package may vary.
Refer to the product data sheet for package details.

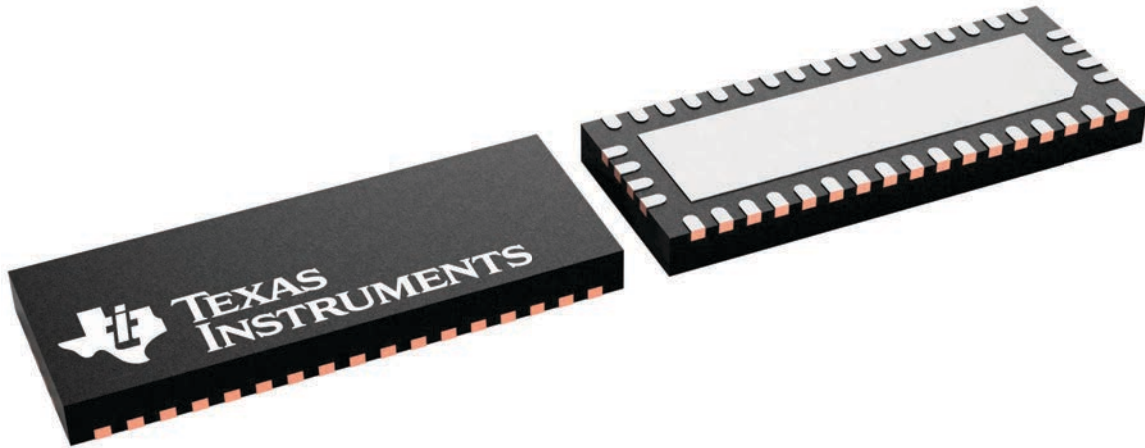

4226504/A

EXAMPLE STENCIL DESIGN

RUA0042A

WQFN - 0.8 mm max height

PLASTIC QUAD FLATPACK - NO LEAD

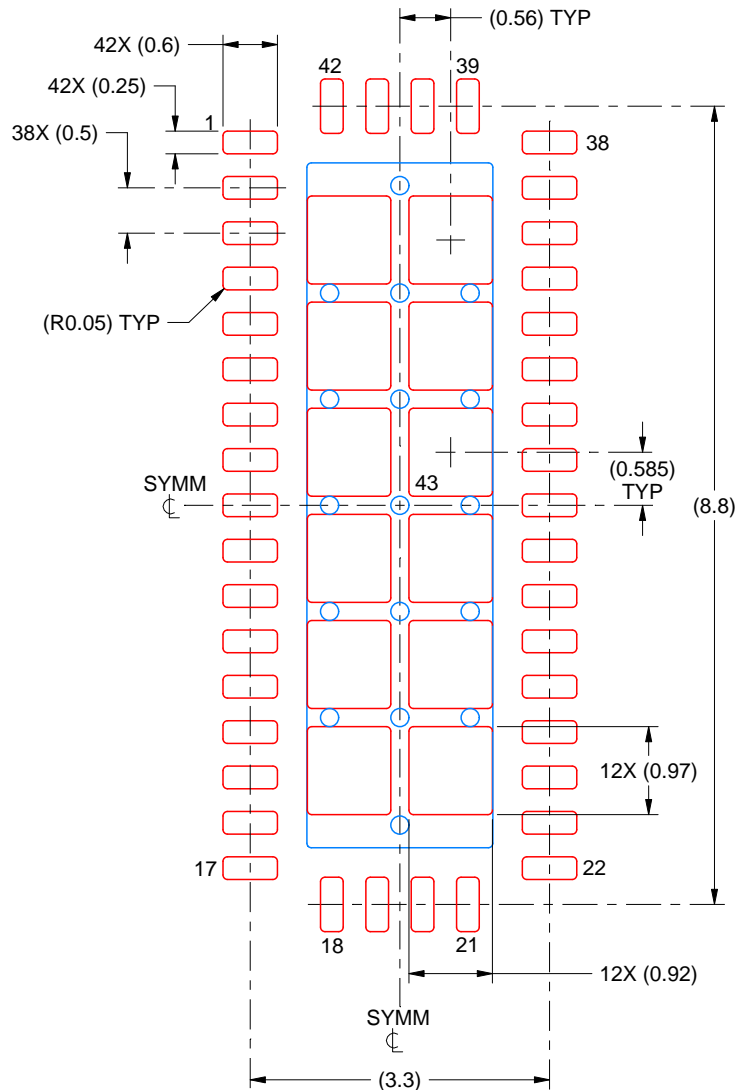

SOLDER PASTE EXAMPLE
BASED ON 0.125 MM THICK STENCIL
SCALE: 12X

EXPOSED PAD 43
69% PRINTED SOLDER COVERAGE BY AREA UNDER PACKAGE

4219139/A 03/2020

NOTES: (continued)

6. Laser cutting apertures with trapezoidal walls and rounded corners may offer better paste release. IPC-7525 may have alternate design recommendations.

IMPORTANT NOTICE AND DISCLAIMER

TI PROVIDES TECHNICAL AND RELIABILITY DATA (INCLUDING DATASHEETS), DESIGN RESOURCES (INCLUDING REFERENCE DESIGNS), APPLICATION OR OTHER DESIGN ADVICE, WEB TOOLS, SAFETY INFORMATION, AND OTHER RESOURCES "AS IS" AND WITH ALL FAULTS, AND DISCLAIMS ALL WARRANTIES, EXPRESS AND IMPLIED, INCLUDING WITHOUT LIMITATION ANY IMPLIED WARRANTIES OF MERCHANTABILITY, FITNESS FOR A PARTICULAR PURPOSE OR NON-INFRINGEMENT OF THIRD PARTY INTELLECTUAL PROPERTY RIGHTS.

These resources are intended for skilled developers designing with TI products. You are solely responsible for (1) selecting the appropriate TI products for your application, (2) designing, validating and testing your application, and (3) ensuring your application meets applicable standards, and any other safety, security, or other requirements. These resources are subject to change without notice. TI grants you permission to use these resources only for development of an application that uses the TI products described in the resource. Other reproduction and display of these resources is prohibited. No license is granted to any other TI intellectual property right or to any third party intellectual property right. TI disclaims responsibility for, and you will fully indemnify TI and its representatives against, any claims, damages, costs, losses, and liabilities arising out of your use of these resources.

TI's products are provided subject to TI's Terms of Sale (<https://www.ti.com/legal/termsofsale.html>) or other applicable terms available either on [ti.com](https://www.ti.com) or provided in conjunction with such TI products. TI's provision of these resources does not expand or otherwise alter TI's applicable warranties or warranty disclaimers for TI products.

Mailing Address: Texas Instruments, Post Office Box 655303, Dallas, Texas 75265
Copyright © 2021, Texas Instruments Incorporated

Looking for pricing, stock, or lifecycle information?

Click below to explore more details on WIN SOURCE:

- ⊖ [View HD3SS3412RUAR](#) on WIN SOURCE
- ⊖ [Texas Instruments](#) Information

Optimize Your Supply Chain with WIN SOURCE Solutions

- ✓ Global Sourcing Solution
- ✓ Obsolete Management
- ✓ Cost Control Management
- ✓ Shortage Management
- ✓ Alternative Solution
- ✓ Excess Inventory Management