

The **ES9028Q2M SABRE³² Reference DAC** is a very high-performance, 32-bit, Stereo audio D/A converter designed for; audiophile-grade portable power sensitive applications such as digital music players, Blu-ray players, audio pre-amplifiers and A/V receivers, and professional applications such as recording systems, mixer consoles and digital audio workstations.

Using the critically acclaimed ESS patented 32-bit HyperStream™ DAC architecture and Time Domain Jitter Eliminator, the **ES9028Q2M SABRE³² Reference DAC** delivers a DNR of up to 129dB and THD+N of –120dB, a performance level that will satisfy the most demanding audio enthusiasts.

The **ES9028Q2M SABRE³² Reference DAC**'s 32-bit HyperStream™ architecture handles up to 32-bit 384kHz PCM data via I²S, DSD-22.6MHz data as well as a mono mode for highest performance applications. Both synchronous and ASRC (asynchronous sample rate conversion) modes are supported.

The **ES9028Q2M SABRE³² Reference DAC** sets the standard, **SABRE SOUND™**, for HD audio performance, typically consumes 83mW in normal operation mode (< 1mW in standby mode), and comes in an easy-to-use, 32-QFN package.

FEATURE	DESCRIPTION
Patented 32-bit HyperStream™ DAC <ul style="list-style-type: none"> +129dB DNR –120dB THD+N 	<ul style="list-style-type: none"> Industry's highest performance 32-bit mobile audio DAC with unprecedented dynamic range and ultra-low distortion Supports both synchronous and ASRC (asynchronous sample rate converter) modes
Patented Time Domain Jitter Eliminator	<ul style="list-style-type: none"> Unmatched audio clarity free from input clock jitter
64-bit accumulator & 32-bit processing	<ul style="list-style-type: none"> Distortion free signal processing
Integrated DSP Functions	<ul style="list-style-type: none"> Click-free soft mute and volume control Programmable Zero detect De-emphasis for 32kHz, 44.1kHz, and 48kHz sampling
Customizable output configuration	<ul style="list-style-type: none"> Stereo or Mono output in current or voltage mode based on performance criterion
I ² C control	<ul style="list-style-type: none"> Allows software control of DAC features
32-QFN (5mm x 5mm) package	<ul style="list-style-type: none"> Minimizes PCB footprint
83mW operating power consumption < 1mW standby power	<ul style="list-style-type: none"> Maximizes battery life
Versatile digital input	<ul style="list-style-type: none"> Supports SLIMbus, SPDIF, PCM (I²S, LJ 16-32-bit) or DSD input
Customizable filter characteristics	<ul style="list-style-type: none"> User programmable filter allowing custom roll-off response Bypassable oversampling filter

APPLICATIONS

- Mobile phones / Tablets / Digital music players / Portable multimedia players
- Blu-ray / SACD / DVD-Audio player
- Audio preamplifiers and A/V receivers
- Professional audio recording systems / Mixing consoles / Digital audio workstations



FUNCTIONAL BLOCK DIAGRAM

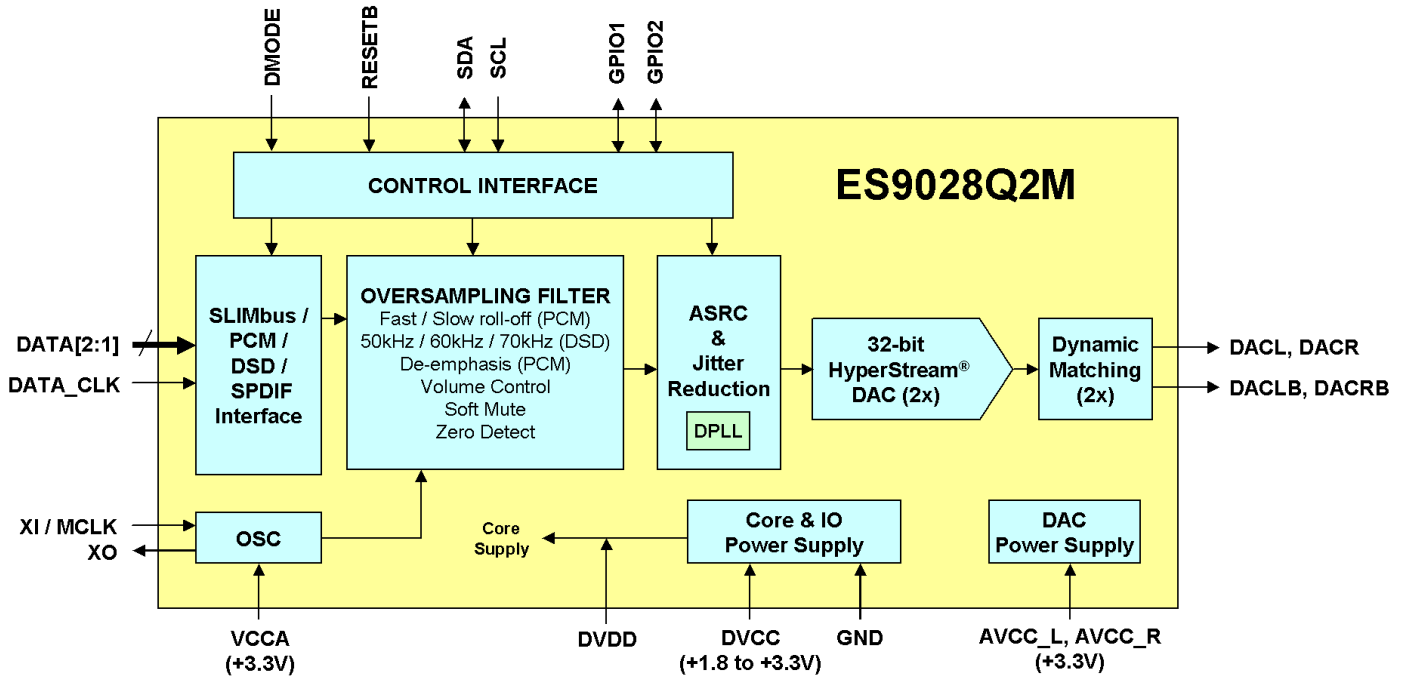

TYPICAL APPLICATION DIAGRAM

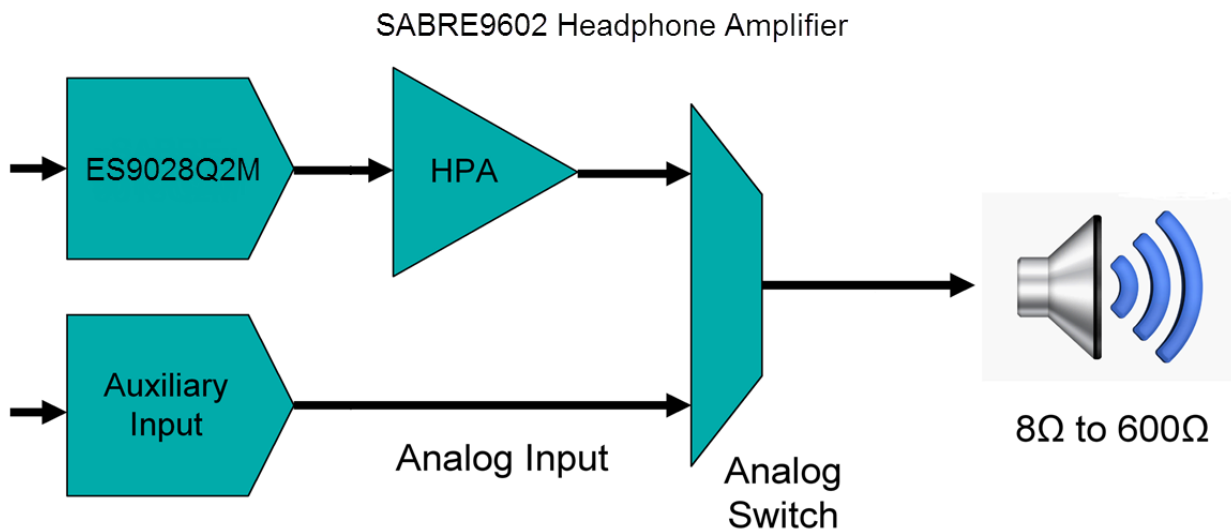



PIN LAYOUT

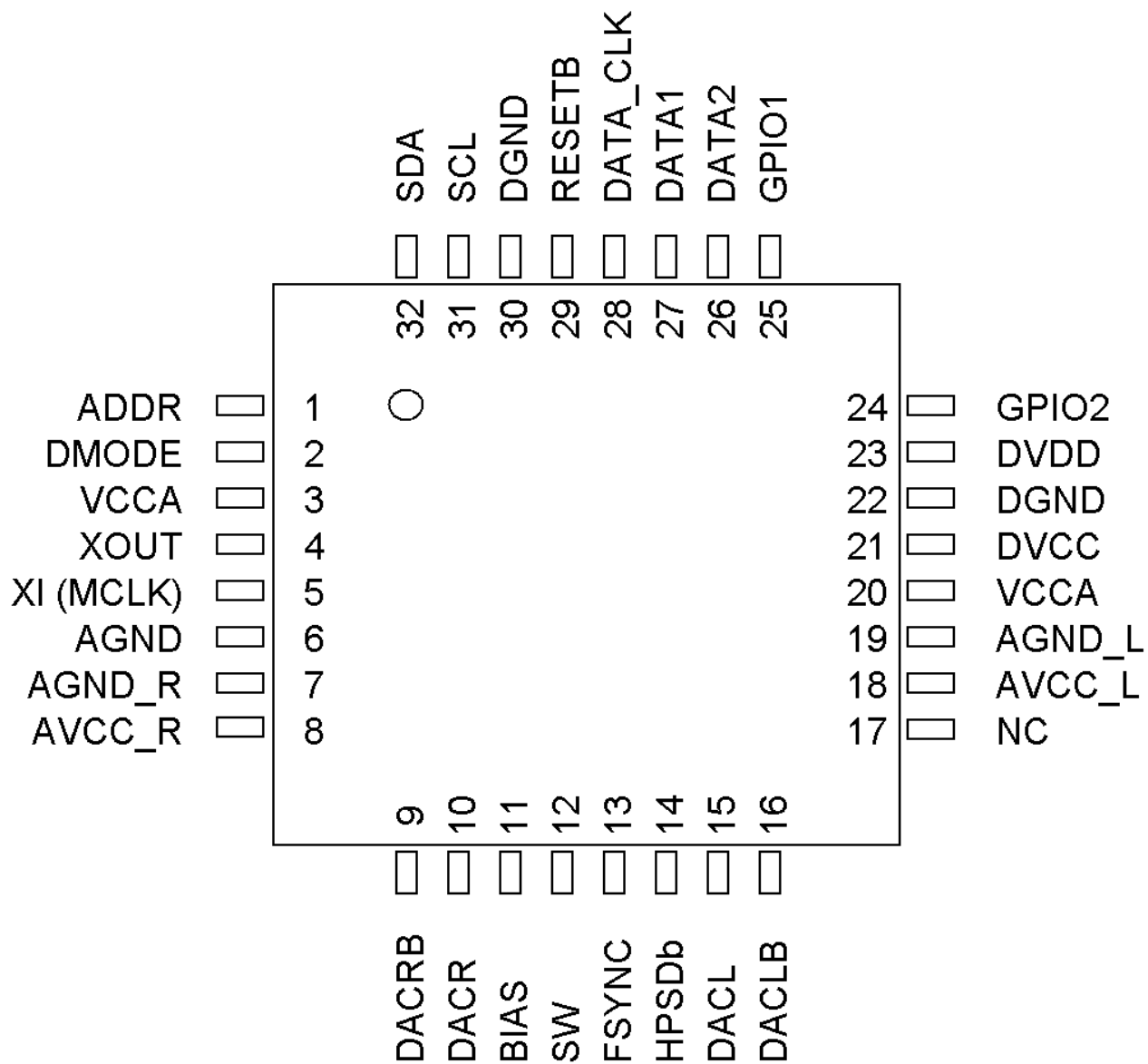



PIN DESCRIPTIONS

Pin	Name	Pin Type	Reset State	Pin Description
1	ADDR	I	Tri-stated	I ² C Address Select
2	DMODE	I	-	Bus type select: 1'b0 for normal serial mode, 1'b1 => SLIMbus mode
3	VCCA	Power	Power	Analog +3.3V for OSC
4	XOUT	AO	Floating	XTAL Output
5	XI (MCLK)	AI	Floating	XTAL / MCLK Input
6	AGND	Ground	Ground	Analog Ground
7	AGND_R	Ground	Ground	Analog Ground for the Right Channel
8	AVCC_R	Power	Power	Analog AVCC for the Right Channel
9	DACRB	AO	Driven to ground	Differential Negative Output for the Right Channel
10	DACR	AO	Driven to ground	Differential Positive Output for the Right Channel
11	BIAS	O	1'b0	General I/O. Controlled by software
12	SW	O	1'b0	General I/O. Can be connected to switch input of SABRE9602
13	FSYNC	O	-	General I/O. Can be connected to FSYNC of SABRE9602
14	HPSDb	O	1'b0	General I/O. Controlled by software. Can be connected to Headphone Shutdown of SABRE9602
15	DACL	AO	Driven to ground	Differential Positive Output for the Left Channel
16	DACLB	AO	Driven to ground	Differential Negative Output for the Left Channel
17	NC	-	-	No internal connection. May be grounded if desired
18	AVCC_L	Power	Power	Analog AVCC for the Left Channel
19	AGND_L	Ground	Ground	Analog Ground for the Left Channel
20	VCCA	Power	Power	Analog +3.3V for OSC
21	DVCC	Power	Power	Digital +1.8V to +3.3V
22	DGND	Ground	Ground	Digital Ground
23	DVDD	Power (Internal / External)	Power	Digital Core Voltage, nominally +1.2V, is supplied by a regulator from DVCC. DVDD should be decoupled with a minimum 4.7 μ F capacitor to DGND. DVDD needs to be externally supplied for high XI / MCLK frequency. Please refer to the section about the DVDD supply on page 8 for additional information.
24	GPIO2	I/O	Tri-stated	GPIO 2
25	GPIO1	I/O	Tri-stated	GPIO 1
26	DATA2	I	Tri-stated	DSD Data2 (R) or PCM Data CH1/CH2 or SPDIF Input 2
27	DATA1	I/O	Tri-stated	Master mode off: Input for DSD Data1 (L) or PCM Frame Clock or SPDIF Input 3 Master mode on: Output for PCM Frame Clock
28	DATA_CLK	I/O	Tri-stated	Master mode off: Input for PCM Bit Clock or DSD Bit Clock or SPDIF Input 1 Master mode on: Output for PCM Bit Clock
29	RESETB	I	Tri-stated	Master Reset / Power Down (active low)
30	DGND	Ground	Ground	Digital Ground
31	SCL	I	Tri-stated	I ² C Serial Clock Input
32	SDA	I/O	Tri-stated	I ² C Serial Data Input/Output
Exposed Pad	AGND	Ground	Ground	The exposed pad must be connected to Analog Ground

ES9028Q2M Datasheet



FUNCTIONAL DESCRIPTION

NOTATIONS for Sampling Rates

Mode	fs (target sample rate)	FSR (raw sample rate)
DSD	DATA_CLK / 64	DSD data rate
Serial (PCM) Normal Mode	Frame Clock Rate	Frame Clock Rate
Serial (PCM) OSF Bypass Mode	Frame Clock Rate / 8	Frame Clock Rate
SPDIF	SPDIF Sampling Rate	SPDIF Sampling Rate

PCM, SPDIF and DSD Pin Connections

PCM Audio Format

Notes:

XI clock (MCLK) must be > 192 x FSR when using PCM input (normal mode), or 128 x FSR (synchronous MCLK).

XI clock (MCLK) must be > 24 x FSR when using PCM input (OSF bypass mode).

Pin Name	Description
DATA1	Frame clock
DATA2	2-channel PCM serial data
DATA_CLK	Bit clock for PCM audio format

Master Mode (32-bit data only)

When Register #1 'input_select' is set to 2'd0 (I²S) and 'i2s_length' is set to 2'd2 (32-bit), the DAC can become a master for Bit Clock and Frame Clock by setting Register #10 'master clock enable' to 1'b1. The Bit Clock frequency can be configured to MCLK / 4, MCLK / 8 or MCLK / 16 by setting Register #10 'clock divider select' to 2'b00, 2'b01 or 2'b10. GPIO 1 (or 2) can be configured to output MCLK by setting Register #8 gpio1_cfg (or gpio2_cfg) to 4'd3.

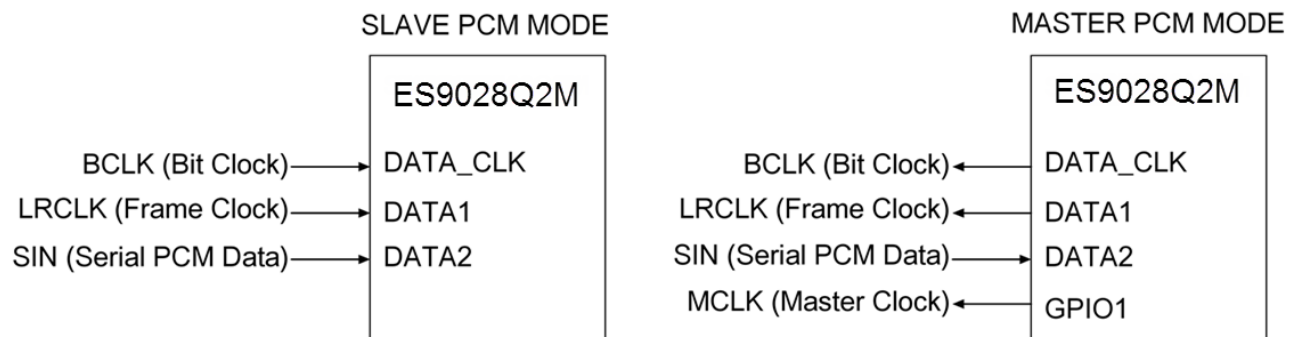



SPDIF Audio Formant

Note: XI clock (MCLK) must be > 386 x FSR when using the SPDIF input.

Up to three SPDIF inputs can be connected to the 3-to-1 mux, selectable via register “spdif_sel”. The SPDIF can also be sourced from GPIO pins configured as inputs.

Pin Name	Description
GPIO2	SPDIF input 5
GPIO1	SPDIF input 4
DATA1	SPDIF input 3
DATA2	SPDIF input 2
DATA_CLK	SPDIF input 1

DSD Audio Format

Note: XI clock (MCLK) must be > 3 x FSR when using the DSD input.

Pin Name	Description
DATA[1:2]	2-channel DSD data input
DATA_CLK	Bit clock for DSD data input

The MCLK will run at 100MHz which means that the maximum DSD clock frequency supported is 33.3MHz. Hence, octuple-rate DSD or DSD-22.6MHz is supported by the ES9028Q2M. Note that it is essential to meet the requirement of $MCLK > 3 \times DSD_CLK$ or the circuit will not function correctly.



FEATURE DESCRIPTIONS

Soft Mute

When Mute is asserted the output signal will ramp to the $-\infty$ level. When Mute is reset the attenuation level will ramp back up to the previous level set by the volume control register. Asserting Mute will not change the value of the volume control register. The ramp rate is $0.0078125 \times fs / 2^{(vol_rate-5)}$ dB/s.

Automute

During an automute condition the ramping of the volume of each DAC to $-\infty$ can now be programmatically enabled or disabled.

- In PCM serial mode, "AUTOMUTE" will become active once the audio data is continuously below the threshold set by <Register Automute_lev>, for a length of time defined by $2096896 / (<Register\#4> \times 64 \times fs)$ Seconds.
- In SPDIF mode, "AUTOMUTE" will become active once the audio data is continuously below the threshold set by <Register Automute_lev>, for a length of time defined by $2096896 / (<Register\#4> \times 64 \times fs)$ Seconds.
- In the DSD Mode, "AUTOMUTE" will become active when any 8 consecutive values in the DSD stream have as many 1's and 0's for a length of time defined by $2096896 / (<Register\ Automute_time> \times DATA_CLK)$ seconds. The following table summarizes the conditions.

Mode	Detection Condition	Time
PCM	Data is continuously lower than <Register Automute_lev >	$2096896 / (<Register\ Automute_time > \times 64 \times fs)$
SPDIF	Data is continuously lower than <Register Automute_lev >	$2096896 / (<Register\ Automute_time > \times (64 \times fs))$
DSD	Equal number of 1s and 0s in every 8 bits of data	$2096896 / (<Register\ Automute_time > \times DATA_CLK)$

Volume Control

Each output channel has its own attenuation circuit. The attenuation for each channel is controlled independently. Each channel can be attenuated from 0dB to -127 dB in 0.5dB steps.

Each 0.5dB step transition takes up to 64 intermediate levels, depending on the vol_rate register setting. The result being that the level changes are done using small enough steps so that no switching noise occurs during the transition of the volume control. When a new volume level is set, the attenuation circuit will ramp softly to the new level.

Master Trim

The master trim sets the 0dB reference level for the volume control of each DAC. The master trim is programmable via registers 17-20 and is a 32-bit signed number. Therefore it should never exceed 32'h7FFFFFFF (as this is full-scale signed).

All Mono Mode

An all mono mode where all DACs are driven from the same source is supported. This can be useful for high-end audio applications. The source data for all DACs can be programmatically configured to be either CH1 or CH2.

De-emphasis

The de-emphasis feature is included for audio data that has utilized the 50/15 μ s pre-emphasis for noise reduction. There are three de-emphasis filters, one for 32kHz, one for 44.1kHz, and one for 48kHz.

SPDIF Data Select

An SPDIF source multiplexer allows for up to three SPDIF sources to be connected to the data pins. An internal programmable register (spdif_sel) is used to select the appropriate data pin to decode. The SPDIF can also be sourced from GPIO pins configured as inputs.



System Clock (XI / MCLK)

A system clock is required for proper operation of the digital filters and modulation circuitry. See page 34, Note 2 for the maximum MCLK frequencies supported. The minimum system clock frequency must also satisfy:

Data Type	Minimum MCLK Frequency	Note
DSD Data	$MCLK > 3 \times FSR$, $FSR = 2.8224\text{MHz}$ (x 1, 2 or 4)	The maximum FSR frequency is further limited by the maximum MCLK frequencies supported as shown on page 34, Note 2.
Serial Normal Mode	$MCLK > 192 \times FSR$, $FSR \leq 384\text{kHz}$ $MCLK = 128 \times FSR$ (synchronous MCLK) with $FSR \leq 384\text{kHz}$	
Serial OSF Bypass Mode	$MCLK > 24 \times FSR$, $FSR \leq 1.536\text{MHz}$	
SPDIF Data	$MCLK > 386 \times FSR$, $FSR \leq 200\text{kHz}$	

Data Clock

DATA_CLOCK must be $(2 \times i2s_length) \times FSR$ for SERIAL, and FSR for DSD modes. For SPDIF mode, this pin is used for SPDIF input. The DATA_CLK pin should be pulled low if not used.

Built-in Digital Filters

Three digital filters are included for PCM data, a fast roll-off filter, a slow roll-off filter, and a minimum phase filter. See 'PCM Filter Characteristics' for more information.

Standby Mode

For lowest power consumption, the following should be performed to enter the stand-by mode:

- Set the soft_start bit in register 14 to '1'b0 to ramp the DAC outputs (DACL, DACLB, DACR, DACRB) to ground.
- RESETB pin should be brought to low digital level to:
 - Shut off the DACs, Oscillator and internal regulator.
 - Force digital I/O pins (DATA_CLK, DATA1, GPIO1, GPIO2, SDA) into tri-state mode
 - Reset all registers to default states
- If XI/MCLK is supplied externally, it should be stopped at a logic low level
- If DVDD is supplied by an external regulator, it should be shut down during standby.

To resume from standby mode, bring RESETB to high digital level and reinitialize all registers.

DVDD Supply

The ES9028Q2M is equipped with a regulated DVDD supply powered from DVCC. The internal DVDD regulator must be decoupled to DGND with a capacitor that maintains a minimum value of $1\mu\text{F}$ at 1.2V over the target operating temperature range. The recommended capacitor for decoupling DVDD is a $4.7\mu\text{F} \pm 20\%$, X5R 6.3V 0402.

- The internal DVDD should be used except under the following conditions:
 1. PCM (SPDIF, I²S with OSF Bypass off or on) with $MCLK > 50\text{MHz}$ or $FSR > 192\text{kHz}$
 2. DSD with $MCLK > 50\text{MHz}$ or $FSR > 11.2\text{MHz}$
- Please refer to page 31, Note 2 for the maximum supported MCLK frequencies. An External DVDD (+1.3V $\pm 5\%$) supply must be used above those frequencies. The external supply voltage should be greater than the internal supply of +1.2V so the internal regulator is disabled.

SLIMbus Mode

The ES9028Q2M supports the Serial Low-power Inter-chip Media Bus (SLIMbus) standard, which is a common interface between application processors and peripheral components in mobile devices. SLIMbus is implemented as a synchronous 2-wire configurable interface. The ES9028Q2M acts as a slave device on the SLIMbus interface, relying on a master to be present to generate clocks and frames.

To enable the SLIMbus mode the DMODE pin is pulled high. When DMODE is high, the DATA_CLK pin becomes SLIMBUS_CLK and the DATA_2 pin becomes SLIMBUS_DATA. The ES9028Q2M now reports itself as 3 valid SLIMbus devices if a valid clock and framer exist.

ES9028Q2M Datasheet



The ES9028Q2M identifies under the following SLIMbus address space:

0x0145C0C70XYX where X is the device and YY is either 00 (ADDR = 0) or 01 (ADDR = 1).

Once the ES9028Q2M has reported that it is present, it is ready to stream audio to the data endpoint. The first step is to assign logical addresses to each of the three devices initialized in the ES9028Q2M.

```
ASSIGN_LOGICAL_ADDRESS Dst = 0x0145C0C70000 LA = 5
ASSIGN_LOGICAL_ADDRESS Dst = 0x0145C0C70100 LA = 6
ASSIGN_LOGICAL_ADDRESS Dst = 0x0145C0C70300 LA = 8
```

For 44.1kHz audio, a root clock that is divisible by 44.1kHz is required. For this we can select the common SLIMbus clock of 22.5792MHz.

```
BEGIN_RECONFIGURATION
NEXT_ROOT_FREQUENCY RF = 2
RECONFIGURE_NOW
```

Now the source audio device is configured, which depends on the baseband or application processor used. Next the SINKs are configured, assuming the same channel and port numbers are used (the same numbers should be used when configuring the audio sources).

```
CONNECT_SINK Src = 0xFF, Dst = 6, CN = 1, PN = 0
CONNECT_SINK Src = 0xFF, Dst = 6, CN = 2, PN = 1
```

The type of audio to be transmitted on the selected channel(s) is now setup. For this example, the transmission is streaming 44.1KHz audio in isochronous mode.

```
BEGIN_RECONFIGURATION
NEXT_DEFINE_CHANNEL CN = 1, SD = 3140, TP = 0, SL = 6 (Channel 1, 3140 segment distribution, iso protocol,
segment length 6)
NEXT_DEFINE_CONTENT CN = 1, FL = 1, PR = 11, AF = 0, DT = 1, CL = 0, DL = 6 (Channel 1, frequency locked, 44.1kHz,
LPCM audio, data length 6)
NEXT_ACTIVATE_CHANNEL CN = 1
RECONFIGURE_NOW
BEGIN_RECONFIGURATION
NEXT_DEFINE_CHANNEL CN = 2, SD = 3146, TP = 0, SL = 6 (Channel 2, 3146 segment distribution, iso protocol,
segment length 6)
NEXT_DEFINE_CONTENT CN = 2, FL = 1, PR = 11, AF = 0, DT = 1, CL = 0, DL = 6 (Channel 1, frequency locked, 44.1kHz,
LPCM audio, data length 6)
NEXT_ACTIVATE_CHANNEL CN = 2
RECONFIGURE_NOW
```

Audio should now be configured to stream between the application processor.

Register reads and writes are also accomplished via SLIMbus by writing to 0x0145C0C703XX. Registers are offset from byte address 0x900. For example, register 0 is at 0x900, register 1 is at 0x901, etc. An example of writing to register 1 is as follows:

```
CHANGE_VALUE Src = 0xFF, Dst = 8, AM = 1, BA = 0x901, SS = 0, VU = 0xF2
```



Programmable FIR filter

A two stage interpolating FIR design is used. The interpolating FIR filter is generated using MATLAB, and can then be downloaded using a custom C code.

Example Source Code for Loading a Filter

```
// only accept 128 or 16 coefficients
// Note: The coefficients must be quantized to 24 bits for this method!
// Note: Stage 1 consists of 128 values (0-127 being the coefficients)
// Note: Stage 2 consists of 16 values (0-13 being the coefficients, 14-15 are zeros)
// Note: Stage 2 is symmetric about coefficient 13. See the example filters for more information.
byte reg26 = (byte)(coeffs.Count == 128 ? 0 : 128);
for (int i = 0; i < coeffs.Count; i++)
{
    // stage 1 contains 128 coefficients, while stage 2 contains 16 coefficients
    registers.WriteRegister(26, (byte)(reg26 + i));

    // write the coefficient data
    registers.WriteRegister(27, (byte)(coeffs[i] & 0xff));
    registers.WriteRegister(28, (byte)((coeffs[i] >> 8) & 0xff));
    registers.WriteRegister(29, (byte)((coeffs[i] >> 16) & 0xff));

    registers.WriteRegister(30, 0x02); // set the write enable bit
}
// disable the write enable bit when we're done
registers.WriteRegister(30, (byte)(setEvenBit ? 0x04 : 0x00));
```

OSF Bypass

The oversampling FIR filter can be bypassed, sourcing data directly into the IIR filter. ESS recommends using 8 x FSR as the input. For example, an external signal at 44.1kHz can be oversampled externally to 8 x 44.1kHz = 352.8kHz and then applied to the serial decoder in either I²S or LJ format. The maximum sample rate that can be applied is 1.536MHz (8 x 192kHz).

THD Compensation

Sabre2M THD Compensation removes the non-linearity of the DAC resistors and to a lesser degree the non-linearity of passive components in the output stage. Taking the I-V characteristic curve of a real resistor you will notice that it has a slight downward curvature. As more current flows, more power dissipates the resistor heats and the resistance rises.

Non-linearity of the DAC output resistors can lead to output distortion in two ways:

- Amplitude modulation of the output current from the DAC
- Gain modulation of the output stage as the output impedance of the DAC swings with the audio signal

The Sabre2M includes models for its output resistors and can compensate for their characteristic curve by finely adjusting the DAC codes for large and small signal amplitudes.

THD Compensation is effective if the base THD+N measurement with no compensation is less than approximately 70dB. If your system performs worse than this, check for other errors with the circuit before applying the THD Compensation.

Registers #13, #22 to #25, and #34 to #38 are used for THD Compensation.

ES9028Q2M Datasheet



Audio Interface Formats

Several interface formats are provided so that direct connection to common audio processors is possible. The available formats are shown in the following diagrams. The audio interface format can be set by programming the registers.

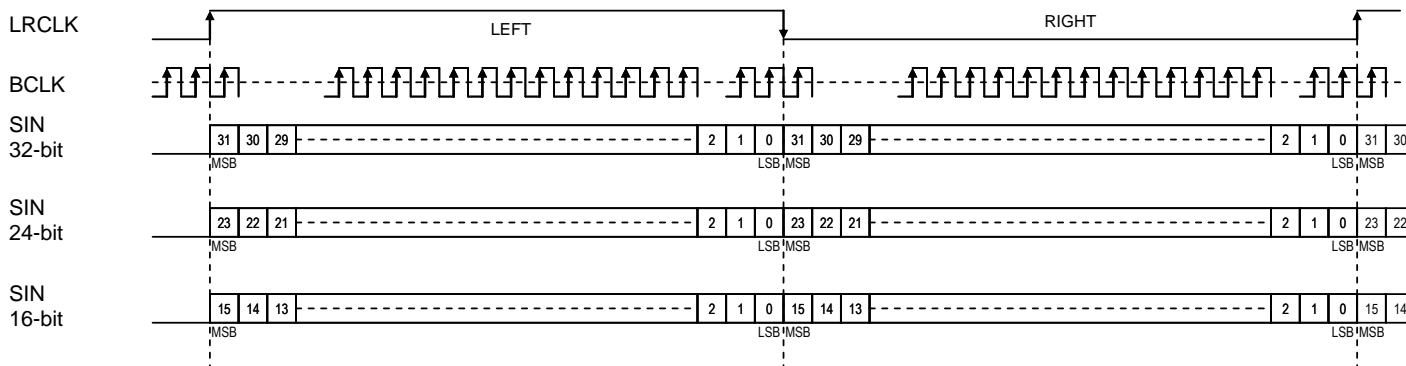

LEFT JUSTIFIED FORMAT

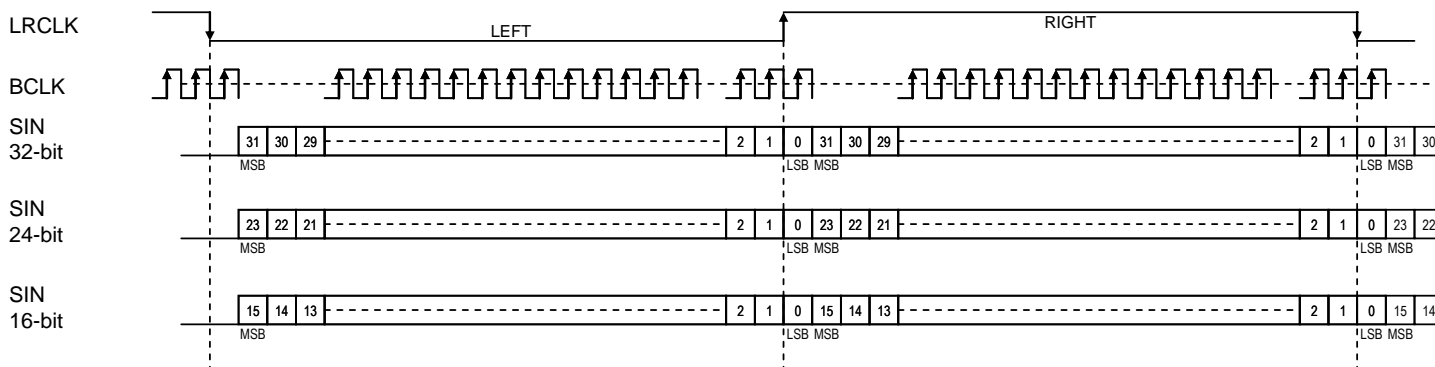

I2S FORMAT

Note: for Left-Justified and I²S formats, the following number of BCLKs is present per (left plus right) frame:

- 16-bit mode: 32 BCLKs
- 24-bit mode: 48 BCLKs
- 32-bit mode: 64 BCLKs

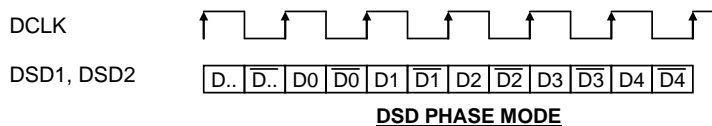
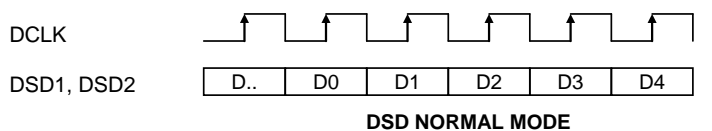



SERIAL CONTROL INTERFACE

The registers inside the chip are programmed via an I²C interface. The diagram below shows the timing for this interface. The chip address can be set to 2 different settings via the “ADDR” pin. The table below summarizes this.

ADDR	CHIP ADDRESS
0	0x90
1	0x92

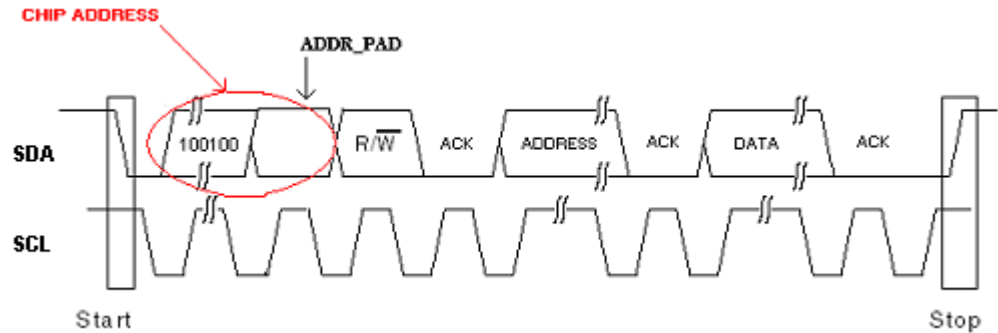

Notes:

1. The “ADDR” pin is used to create the CHIP ADDRESS. (0x90, 0x92)
2. The first byte after the chip address is the “ADDRESS” this is the register address.
3. The second byte after the CHIP ADDRESS is the “DATA” this is the data to be programmed into the register at the previous “ADDRESS”.

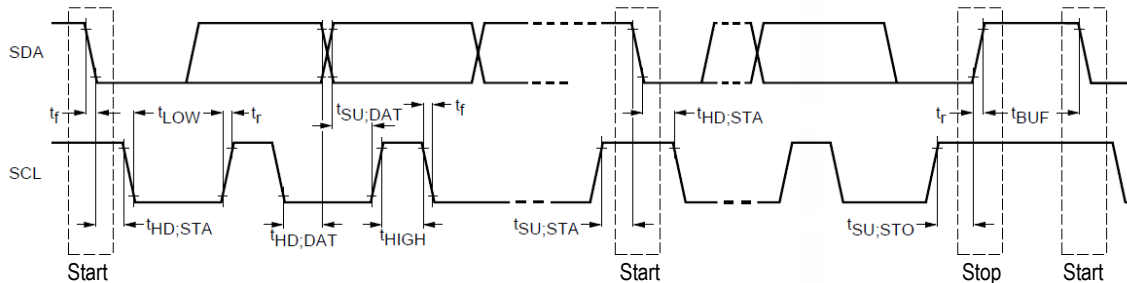

Parameter	Symbol	Standard Mode		Fast-Mode		Unit
		MIN	MAX	MIN	MAX	
SCL Clock Frequency	f_{SCL}	0	100	0	400	kHz
START condition hold time	$t_{HD,STA}$	4.0	-	0.6	-	μ s
LOW period of SCL	t_{LOW}	4.7	-	1.3	-	μ s
HIGH period of SCL	t_{HIGH}	4.0	-	0.6	-	μ s
START condition setup time (repeat)	$t_{SU,STA}$	4.7	-	0.6	-	μ s
SDA hold time from SCL falling	$t_{HD,DAT}$	0.3	-	0.3	-	μ s
SDA setup time from SCL rising	$t_{SU,DAT}$	250	-	100	-	ns
Rise time of SDA and SCL	t_r	-	1000	-	300	ns
Fall time of SDA and SCL	t_f	-	300	-	300	ns
STOP condition setup time	$t_{SU,STO}$	4	-	0.6	-	μ s
Bus free time between transmissions	t_{BUF}	4.7	-	1.3	-	μ s
Capacitive load for each bus line	C_b	-	400	-	400	pF

ES9028Q2M Datasheet



REGISTER SETTINGS

Register #0: System Settings

8 bit, Read-Write Register, Default = 0x00

Bits	[7]	[6]	[5]	[4]	[3]	[2]	[1]	[0]
Mnemonic	osc_drv				reserved *			soft_reset
Default	0	0	0	0	0	0	0	0

Bit	Mnemonic	Description
[7:4]	osc_drv	Oscillator drive specifies the bias current to the oscillator pad. <ul style="list-style-type: none"> 4'b0000: full bias (default) 4'b1000: 3/4 bias 4'b1100: 1/2 bias 4'b1110: 1/4 bias 4'b1111: shut down the oscillator Other settings: reserved It is recommended to use the default setting.
[3:1]	reserved *	
[0]	soft_reset	1'b0 is normal operation (default) 1'b1 resets chip

* All Reserved Bits in Register #0 must be set to the indicated logic level to ensure correct device operation.

Register #1: Input Configuration

8 bit, Read-Write Register, Default = 0x8C

Bits	[7]	[6]	[5]	[4]	[3]	[2]	[1]	[0]
Mnemonic	i2s_length		i2s_mode		auto_input_select		input_select	
Default	1	0	0	0	1	1	0	0

Bit	Mnemonic	Description
[7:6]	i2s_length	2'd0 = 16bit 2'd1 = 24bit 2'd2 or 2'd3 = 32bit (default)
[5:4]	i2s_mode	2'd0 = I ² S (default) 2'd1 = LJ mode 2'd2 = I ² S 2'd3 = LJ mode
[3:2]	auto_input_select	2'd0 = 'input select', 2'd1 = I ² S or DSD, 2'd2 = I ² S or SPDIF, 2'd3 = I ² S, SPDIF or DSD (default)
[1:0]	input_select	2'd0 = I ² S (default) 2'd1 = SPDIF 2'd2 = reserved 2'd3 = DSD



Register #4: Soft Volume Control 1 (Automute Time)

8 bit, Read-Write Register, Default = 0x00

Bits	[7]	[6]	[5]	[4]	[3]	[2]	[1]	[0]
Mnemonic	automute_time							
Default	0	0	0	0	0	0	0	0

Bit	Mnemonic	Description
[7:0]	automute_time	Default of 8'd0 (Automute Disabled) Time in Seconds = 2096896 / (automute_time x DATA_CLK) with DATA_CLK in Hz

Register #5: Soft Volume Control 2 (Automute Level)

8 bit, Read-Write Register, Default = 0x68

Bits	[7]	[6]	[5]	[4]	[3]	[2]	[1]	[0]
Mnemonic	automute_loopback	automute_level						
Default	0	1	1	0	1	0	0	0

Bit	Mnemonic	Description
[7]	automute_loopback	1'b0 disables automute_loopback (default) 1'b1 ramps to -infinity on automute
[6:0]	automute_level	The level (in 1dB increments) of the automute, default of 7'd104

Register #6: Soft Volume Control 3 and De-emphasis

8 bit, Read-Write Register, Default = 0x4A

Bits	[7]	[6]	[5]	[4]	[3]	[2]	[1]	[0]
Mnemonic	spdif_auto_deemph	deemph_bypass	deemph_sel	reserved *	vol_rate			
Default	0	1	0	0	1	0	1	0

Bit	Mnemonic	Description
[7]	spdif_auto_deemph	1'b1 enables automatic de-emphasis select in SPDIF mode 1'b0 disables automatic de-emphasis select in SPDIF mode (default)
[6]	deemph_bypass	1'b1 disabled de-emphasis filters (default) 1'b0 enables de-emphasis filters
[5:4]	deemph_sel	2'b00 = 32kHz (default) 2'b01 = 44.1kHz 2'b10 = 48kHz 2'b11 = RESERVED
[3]	reserved *	Must be left as 1'b1 for normal operation
[2:0]	vol_rate	3'd2 by default Sets the volume ramp rate to $0.0078125 \times fs / 2^{(vol_rate-5)}$ dB/s

* All Reserved Bits in Register #6 must be set to the indicated logic level to ensure correct device operation.

ES9028Q2M Datasheet



Register #7: General Settings

8 bit, Read-Write Register, Default = 0x80

Bits	[7]	[6]	[5]	[4]	[3]	[2]	[1]	[0]
Mnemonic	reserved *	filter_shape	reserved *	iir_bw	mute			
Default	1	0	0	0	0	0	0	0

Bit	Mnemonic	Description
[7]	reserved *	
[6:5]	filter_shape	2'd0 = fast rolloff (default) 2'd1 = slow rolloff 2'd2 = minimum phase 2'd3 = reserved
[4]	reserved *	
[3:2]	iir_bw	2'd0 = 1.0757 x fs or 47.44kHz (fs = 44.1kHz) – Normal mode (default) 2'd1 = 1.1338 x fs or 50kHz (fs = 44.1kHz) 2'd2 = 1.3605 x fs or 60kHz (fs = 44.1kHz) 2'd3 = 1.5873 x fs or 70kHz (fs = 44.1kHz)
[1:0]	mute	This is a soft mute, which uses the ramping volume control. Mute[0] <ul style="list-style-type: none"> 1'b0: Channel 1 (default of left channel) un-muted (default) 1'b1: Channel 1 (default of left channel) muted Mute[1] <ul style="list-style-type: none"> 1'b0: Channel 2 (default of right channel) un-muted (default) 1'b1: Channel 2 (default of right channel) muted

* All Reserved Bits in Register #7 must be set to the indicated logic level to ensure correct device operation.



Register #8: GPIO Configuration

8 bit, Read-Write Register, Default = 0x88

Bits	[7]	[6]	[5]	[4]	[3]	[2]	[1]	[0]
Mnemonic	gpio2_cfg				gpio1_cfg			
Default	1	0	0	0	1	0	0	0

Bit	Mnemonic	Description
[7:4]	gpio2_cfg	Set GPIO 2 configuration. Default to 4'd8 (DPLL Lock Status). See GPIO Configuration Table below for meaning of all settings.
[3:0]	gpio1_cfg	Set GPIO 1 configuration Default to 4'd8 (Automute Status). See GPIO Configuration Table below for meaning of all settings.

GPIO Configuration Table

Setting	Direction	GPIO Function
4'd0	Output	Automute status (active high) – asserted when Automute condition is met
4'd1	Output	DPLL Lock status (active high) – asserted when DPLL is in lock
4'd2	Output	Minimum Volume (active high) - asserted when volume of both the left & right channels has ramped to its minimum value (–127.5dB)
4'd3	Output	MCLK
4'd4	Output	DPLL Lock interrupt (active high) - asserted when DPLL Lock status changes state - reading register 64 clears the interrupt
4'd5	Output	Automute Interrupt (active high) - asserted when Automute status changes state - reading register 64 clears the interrupt
4'd6	Output	DPLL Lock or Automute interrupt (active high) - asserted when DPLL Lock or Automute status changes state - reading register 64 clears the interrupt
4'd7	Output	Output low
4'd8	Input	Used as an input pin – pin status can be read from register #65.
4'd9	Input	Input Selection – uses the GPIO as an input select based on register #21
4'd15	Output	Output high

Register #9: Reserved

ES9028Q2M Datasheet



Register #10: Master Mode Control

8 bit, Read-Write Register, Default = 0x2

Bits	[7]	[6]	[5]	[4]	[3]	[2]	[1]	[0]
Mnemonic	master_clock_enable	clock_divider_select	sync_mode	stop_div				
Default	0	0	0	0	0	0	1	0

Bit	Mnemonic	Description
[7]	master_clock_enable	1'b0 disables master mode (default) 1'b1 enables master mode (driving Bit clock and Frame Clock)
[6:5]	clock_divider_select	2'b00: Bit Clock frequency = MCLK / 4 (default) 2'b01: Bit Clock frequency = MCLK / 8 2'b10: Bit Clock frequency = MCLK / 16 2'b11: Bit Clock frequency = MCLK / 16 Frame Clock frequency = Bit Clock frequency / 64
[4]	sync_mode	1'b0 for normal operation of the DPLL and ASRC. 1'b1 to enable quick lock if the fs & MCLK are synchronous & MCLK is 128 x FSR. Note: quick lock can only be used in PCM normal mode
[3:0]	stop_div	Sets the number of FSR edges that must occur before the DPLL and ASRC can lock on to the incoming signal. 4'd0 = 16384 FSR edges 4'd1 = 8192 FSR edges 4'd2 = 5461 FSR edges (default) 4'd3 = 4096 FSR edges 4'd4 = 3276 FSR edges 4'd5 = 2730 FSR edges 4'd6 = 2340 FSR edges 4'd7 = 2048 FSR edges 4'd8 = 1820 FSR edges 4'd9 = 1638 FSR edges 4'd10 = 1489 FSR edges 4'd11 = 1365 FSR edges 4'd12 = 1260 FSR edges 4'd13 = 1170 FSR edges 4'd14 = 1092 FSR edges 4'd15 = 1024 FSR edges

For correct operation, master mode should only be enabled when the DAC's input mode is set to I²S, and when i2s_length is set to 32-bit and i2s_mode is set to I²S in register 1.

When master mode is enabled, the DATA_CLK pin will output Bit Clock and the DATA1 pin will output Frame Clock at frequencies specified by clock divider select.

When PCM data with FSR > 96kHz is used, stop_div should be set to 4'd0 (16384 FSR edges).



Register #11: Channel Mapping

8 bit, Read-Write Register, Default = 0x02

Bits	[7]	[6]	[5]	[4]	[3]	[2]	[1]	[0]
Mnemonic	reserved *	spdif_sel			ch2_analog_swap	ch1_analog_swap	ch2_sel	ch1_sel
Default	0	0	0	0	0	0	1	0

Bit	Mnemonic	Description
[7]	reserved *	
[6:4]	spdif_sel	select the spdif data source 3'd0 = DATA_CLK (default) 3'd1 = DATA $\bar{2}$ 3'd2 = DATA1 3'd3 = GPIO1 3'd4 = GPIO2 3'd5-7: reserved
[3]	ch2_analog_swap	1'b0 = normal operation (default) 1'b1 = swap dac and dacb
[2]	ch1_analog_swap	1'b0 = normal operation (default) 1'b1 = swap dac and dacb
[1]	ch2_sel	1'b0 = left 1'b1 = right (default)
[0]	ch1_sel	1'b0 = left (default) 1'b1 = right

* All Reserved Bits in Register #11 must be set to the indicated logic level to ensure correct device operation.

Left and Right channels can be reversed using Register #11.

ES9028Q2M Datasheet



Register #12: DPLL/ASRC Settings

8 bit, Read-Write Register, Default = 0x5A

Bits	[7]	[6]	[5]	[4]	[3]	[2]	[1]	[0]
Mnemonic	dpll_bw_i2s				dpll_bw_dsd			
Default	0	1	0	1	1	0	1	0

Bit	Mnemonic	Description
[7:4]	dpll_bw_i2s	DPLL bandwidth setting for I ² S and SPDIF modes (16 settings) 4'b0000 : OFF 4'b0001 : Lowest Bandwidth 4'b0101 : (default) 4'b1010 : 4'b1111 : Highest Bandwidth
[3:0]	dpll_bw_dsd	DPLL bandwidth setting for DSD mode (16 settings) 4'b0000 : OFF 4'b0001 : Lowest Bandwidth 4'b0101 : 4'b1010 : (default) 4'b1111 : Highest Bandwidth

The ES9028Q2M contains a Jitter Eliminator block, which employs the use of a digital phase locked loop (DPLL) to lock to the incoming audio clock rate. When in I²S or SPDIF mode, the DPLL will lock to the frame clock (1 x fs). However, when in DSD mode, the DPLL has no frame clock information, and must instead lock to the bit clock rate (BCK). For this reason, there are two bandwidth settings for the DPLL.

Register #12 [7:4] (0x05 default) contains the bandwidth setting for I²S / SPDIF mode.

Register #12 [3:0] (0x0A default) contains the bandwidth setting for DSD mode.

The DPLL bandwidth sets how quickly the DPLL can adjust its internal representation of the audio clock. The higher the jitter or frequency drift on the audio clock, the higher the DPLL bandwidth must be so that the DPLL can react.



Register #13: THD Compensation

8-bit, Read-Write Register, Default = 0x40

Bits	[7]	[6]	[5]	[4]	[3]	[2]	[1]	[0]
Mnemonic	reserved *	bypass_thd	reserved *					
Default	0	1	0	0	0	0	0	0

Bit	Mnemonic	Description
[7]	reserved	
[6]	bypass_thd	1'b0: enable THD compensation <ul style="list-style-type: none"> output = input + (input²) x thd_comp_c2 + (input³) x thd_comp_c3 thd_comp_c2 is stored in registers 23-22 (16 bits signed) (register 23 stores MSBs) thd_comp_c3 is stored in registers 25-24 (16 bits signed) (register 25 stores MSBs) 1'b1: disable THD compensation (default) <ul style="list-style-type: none"> PCM mode: output = input; DSD mode: output = input / 2
[5:0]	reserved	

* All reserved Bits in Register #13 must be set to the indicated logic level to ensure correct device operation

THD compensation can be used to reduce the 2nd and 3rd harmonic distortion introduced by external output drivers. A system level tuning is required to arrive at the optimum coefficients for thd_comp_c2 and thd_comp_c3.

Notes

- To get the same gain (output = input) for PCM and DSD modes without THD compensation, bypass_thd should be set to 1'b0 with thd_comp_c2 and thd_comp_c3 set to 16'd0 (default)
- Erroneous compensation can lead to higher distortion than the one without compensation. If accurate tuning cannot be performed, thd_comp_c2 and thd_comp_c3 should be set to 16'd0 (default) if bypass_thd is set to 1'b0.

Register #14: Soft Start Settings

8 bit, Read-Write Register, Default = 0x8A

Bits	[7]	[6]	[5]	[4]	[3]	[2]	[1]	[0]
Mnemonic	soft_start	soft_start_on_lock	mute_on_lock	soft_start_time				
Default	1	0	0	0	1	0	1	0

Bit	Mnemonic	Description
[7]	soft_start	1'b0: Ramp the output stream to ground 1'b1: Normal operation (default) – ramp the output stream to ½ x AVCC_L/R
[6]	soft_start_on_lock	1'b0: Do not force output low when lock is lost (default) 1'b1: Force output low when lock is lost
[5]	mute_on_lock	1'b0: Do not force a mute when lock is lost (default) 1'b1: Force a mute when lock is lost
[4:0]	soft_start_time	Time for soft start ramp = 4096 x 2 ^(soft_start_time+1) / MCLK seconds (where MCLK is measured in Hz). The valid range of soft-start_time is from 0 to 20.

ES9028Q2M Datasheet



Register #15: Volume 1 (usually selected for the Left Channel, but can be reversed using Register #11)

8 bit, Read-Write Register, Default = 0x50

Bits	[7]	[6]	[5]	[4]	[3]	[2]	[1]	[0]
Mnemonic	volume1							
Default	0	1	0	1	0	0	0	0

Bit	Mnemonic	Description
[7:0]	volume1	Default to 8'd80 (-40dB) 0dB to -127.5dB in 0.5dB steps

Register #16: Volume 2 (usually selected for the Right Channel, but can be reversed using Register #11)

8 bit, Read-Write Register, Default = 0x50

Bits	[7]	[6]	[5]	[4]	[3]	[2]	[1]	[0]
Mnemonic	volume2							
Default	0	1	0	1	0	0	0	0

Bit	Mnemonic	Description
[7:0]	volume2	Default to 8'd80 (-40dB) 0dB to -127.5dB in 0.5dB steps

Register #20-17: Master Trim

32 bit, Read-Write Register, Default = 32'h7ffffff. Reg 20 are the MSB's, Reg 17 are the LSBs.

Bits	[31:0]
Mnemonic	master_trim
Default	32'h7ffffff

This is a 32 bit value that sets the 0dB level for all volume controls. This is a signed number, so it should never exceed 32'h7ffffff (which is $2^{31} - 1$).



Register #21: GPIO Input Selection and OSF Bypass

8 bit, Read-Write Register, Default = 0x00

Bits	[7:6]	[5:4]	[3]	[2]	[1]	[0]	
Mnemonic	gpio_input_sel2		gpio_input_sel1	reserved *	bypass_iir	reserved *	bypass_osf
Default	0	0	0	0	0	0	0

Bit	Mnemonic	Description
[7:6]	gpio_input_sel2	Selects which input will be selected when GPIOX = 1'b1 2'd0 = I ² S data (default) 2'd1 = SPDIF data 2'd2 = reserved 2'd3 = DSD data
[5:4]	gpio_input_sel1	Selects which input will be selected when GPIOX = 1'b0 2'd0 = I ² S data (default) 2'd1 = SPDIF data 2'd2 = reserved 2'd3 = DSD data
[3]	reserved *	
[2]	bypass_iir	1'b0 = Use the IIR filter (default) 1'b1 = Bypass the IIR filter.
[1]	reserved	
[0]	bypass_osf	1'b0 = Use the interpolating 8x FIR filter (default) 1'b1 = Bypass the interpolating 8x FIR filter. Note: Bypassing the interpolating filter requires that the input data be oversampled at 8x fs by an external oversampling filter

* All Reserved Bits in Register #21 must be set to the indicated logic level to ensure correct device operation.

Note: Any of the GPIO can be configured to be used as an input select. This allows an external MCU or controller to set the input type by setting the GPIO to either logic high (1'b1) or logic low (1'b0). To set this feature, the first step is to enable one of the GPIO as an input select by setting gpio_cfg to 4'd9. Once a GPIO is configured as an input select it has the ability to select between two different inputs. The first input (logic low) is set via register 21[5:4]. The second input (logic high) is set via register 21[7:6]. Only one GPIO should be configured as an input select, and the ES9028Q2M will only use the first GPIO if multiple GPIOs are configured as an input selection.

ES9028Q2M Datasheet



Register #23-22: 2nd Harmonic Compensation Coefficients (both channels)

16 bit, Read-Write Register, Default = 0x0000 (no compensation). Register #23 is MSB.
See Registers #13 and #34-38 for more details.

Bits	[15:0]
Mnemonic	Thd_comp_c2
Default	16'd0

Register #25-24: 3rd Harmonic Compensation Coefficients (both channels)

16 bit, Read-Write Register, Default = 0x0000 (no compensation). Register #25 is MSB.
See Registers #13 and #34-38 for more details.

Bits	[15:0]
Mnemonic	Thd_comp_c3
Default	16'd0

The THD Compensation registers are signed integer values split into two memory locations each.

THD Compensation Coefficient	MSB	LSB
x^3 (third harmonic)	Register 25	Register 24
x^2 (second harmonic)	Register 23	Register 22

Table 1: THD Compensation Registers

1. Configure the output stage gain for the maximum desired output level. ***If any component values are later changed on the output audio signal path you will need to re-tune the THD Compensation to achieve peak performance.***

2. Set the input level, Sabre2M Volume and Master Trim for the maximum desired output level.

If the output level is later increased beyond this level you will need to re-tune the THD Compensation to achieve peak performance.

3. Adjust registers 0x23 and 0x25 to achieve peak THD performance. Use the I²C interface or the Sabre2M GUI to make the adjustments while watching the THD+N measurement.

In the GUI, adjust the THD Compensation sliders as shown in figure 1. The sliders are linked to the MSB of the THD Compensation registers so they are somewhat coarse.

Both channels are tuned simultaneously; keep an eye on both measurements.

Typical register values are very close to zero.

4. For finer adjustments use registers 0x22 and 0x24. Use the I²C interface or the Sabre2M GUI to make large changes of 50 or so while watching the THD+N measurement. Switch to smaller increments when you're close to peak performance.

In the GUI, open the register listing (see figure 2) and click Update Registers to make sure the most up-to-date values are displayed. There are no sliders for the fine-adjust registers (see figure 3).

The Sabre2M GUI is available for download from the ESS website at:

64-Bit: http://www.esstech.com/software/Sabre2M_signed_x64.zip

32-Bit: http://www.esstech.com/software/Sabre2M_signed_x86.zip

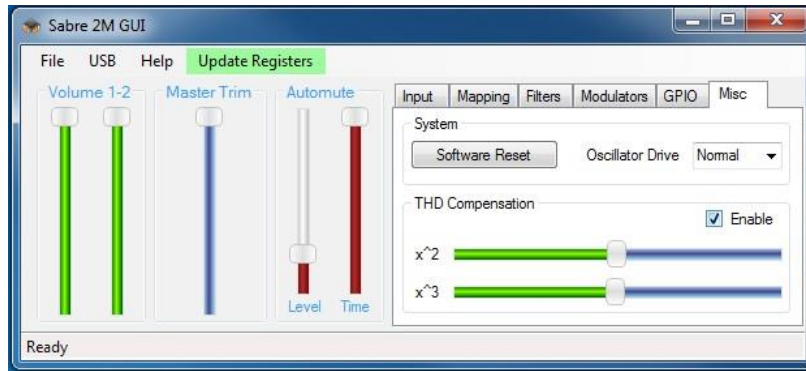

Figure 1. THD Compensation

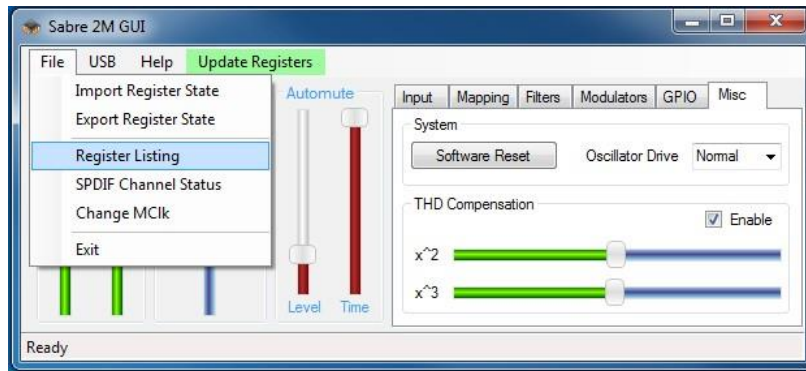

Figure 2. Opening the register listing

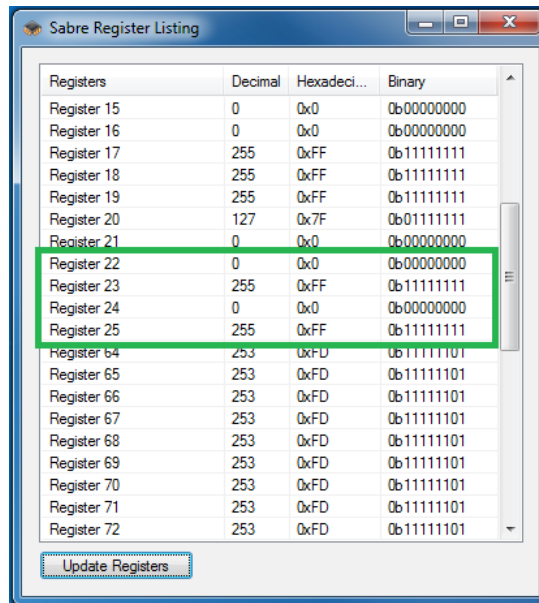

Figure 3. THD Compensation Registers in the register listing

ES9028Q2M Datasheet



Register #26: Programmable Filter Address

8 bit, Read-Write Register, Default = 0x00

Bits	[7]	[6:0]
Mnemonic	prog_coeff_stage	prog_coeff_addr
Default	0	0 0 0 0 0 0 0

Bit	Mnemonic	Description
[7]	prog_coeff_stage	Selects which stage of the filter to write. 1'b0 = Stage 1 of the oversampling filter (128 coefficients). 1'b1 = Stage 2 of the oversampling filter (16 coefficients).
[6:0]	prog_coeff_addr	Selects the coefficient address when writing custom coefficients for the oversampling filter.

Register #29-27: Programmable Filter Coefficient

8 bit, Read-Write Register, Default = 0x000000

Bits	[23:0]
Mnemonic	prog_coeff
Default	24'd0

Bit	Mnemonic	Description
[23:0]	prog_coeff	A 24-bit filter coefficient that will be written to address 'prog_coeff_addr'.

Register #30: Programmable Filter Control

8 bit, Read-Write Register, Default = 0x00

Bits	[7:3]	[2]	[1]	[0]
Mnemonic	reserved *	even_stage2_coeff	prog_coeff_we	prog_coeff_en
Default	0 0 0 0 0	0	0	0

Bit	Mnemonic	Description
[7:3]	reserved *	
[2]	even_stage2_coeff	Sets the type of symmetry of the stage 2 programmable filter. 1'b0 = Uses a sine symmetric filter (27 coefficients). 1'b1 = Uses a cosine symmetric filter (28 coefficients).
[1]	prog_coeff_we	1'b0 = Disable writing to the custom filter coefficients. 1'b1 = Enable writing to the custom filter coefficients. Note: When set to 1'b1 the custom filter will be bypassed regardless of the state of register 21[0].
[0]	prog_coeff_en	1'b0 = Use one of the built-in oversampling filters. 1'b1 = Use the custom oversampling filter. Note: The custom filter is not programmed to anything on reset, valid coefficients must be written to the filter before enabling.

* All Reserved Bits in Register #30 must be set to the indicated logic level to ensure correct device operation.

Note: even_stage2_coeff sets the type of symmetry used by the second stage filter. The actual RAM is 16 coefficients, but only the first 14 coefficients are used when applying the oversampling filter. The first 14 coefficients are mirrored using either sine or cosine symmetry, resulting in a filter length of either 27 or 28 taps. This means that the second stage RAM should only contain half of the impulse response of the second stage filter, and the impulse peak value will be contained in the 14th coefficient. Also note that, due to the symmetry of the filter, only linear phase filters may be used in the second stage.



Register #35-34: Right Channel 2nd Harmonic Compensation Coefficients

16-bit, Read-Write Register, Default = 0x0000 (no compensation). Register #35 is MSB.
See Registers #13, #22-25, and #38 for more details.

Bits	[15:0]
Mnemonic	Thd_comp_c2_right
Default	16'd0

Register #37-36: Right Channel 3rd Harmonic Compensation Coefficients

16-bit, Read-Write Register, Default = 0x0000 (no compensation). Register #37 is MSB.
See Registers #13, #22-25, and #38 for more details.

Bits	[15:0]
Mnemonic	Thd_comp_c3_right
Default	16'd0

Register #38: Separate THD Compensation

8-bit, Read-Write Register, Default = 0x00

Bits	[7:1]	[0]
Mnemonic	reserved *	enable_separate_thd_comp
Default	0	0

Bit	Mnemonic	Description
[7:1]	reserved *	
[0]	enable_separate_thd_comp	1'b0: (default) <ul style="list-style-type: none"> left/right THD compensation coefficients are taken from registers #25-22 1'b1: <ul style="list-style-type: none"> left THD compensation coefficients are taken from registers #25-22 right THD compensation coefficients are taken from registers #37-34

* All Reserved Bits in Register #38 must be set to the indicated logic level to ensure correct device operation.

ES9028Q2M Datasheet



Register #43: SLIMbus Control

8-bit, Read-Write Register, Default = 0x00

Bits	[7:4]	[3]	[2]	[1]	[0]
Mnemonic	reserved *	sb_aux_wk_en	sb_aux_wk_override	sb_drv_strength_en	sb_drv_strength_override
Default	0	0	0	0	0

Bit	Mnemonic	Description
[7:4]	reserved *	
[3]	sb_aux_wk_en	1'b1 = enables the aux weak enable (only when override is set to 1'b1) 1'b0 = disables the aux weak enable (default)
[2]	sb_aux_wk_override	1'b1 = enables the override on SLIMbus aux weak 1'b0 = disables the override on SLIMbus aux weak (default)
[1]	sb_drv_strength_en	1'b1 = sets the SLIMbus drive strength enable (only when override is set to 1'b1) 1'b0 = disables the SLIMbus drive strength enable (default)
[0]	sb_drv_strength_override	1'b1 = enables the override on SLIMbus drive strength 1'b0 = disables the override on SLIMbus drive strength (default)

* All Reserved Bits in Register #43 must be set to the indicated logic level to ensure correct device operation.

Register #64: Chip Status

8 bit, Read-Only Register

Bits	[7]	[6]	[5]	[4]	[3]	[2]	[1]	[0]
Mnemonic	reserved	revision	chip_id	automute_status	lock_status			

Bit	Mnemonic	Description
[7:6]	reserved	
[5]	revision	0'
[4:2]	chip_id	3'd1 => ES9028Q2M
[1]	automute_status	1'b0 => Automute condition is inactive. 1'b1 => Automute condition is active.
[0]	lock_status	1'b0 => The Jitter Eliminator is not locked to an incoming signal. 1'b1 => The Jitter Eliminator is locked to an incoming signal.

Register #65: GPIO Status

8 bit, Read-Only Register

Bits	[7]	[6]	[5]	[4]	[3]	[2]	[1]	[0]
Mnemonic	reserved						gpio_l[1:0]	

Bit	Mnemonic	Description
[7:2]	reserved	
[1]	gpio_l[1]	Status of pin GPIO2
[0]	gpio_l[0]	Status of pin GPIO1



Register #69-66: DPLL Ratio

32 bit, Read-Only Register. Register #69 contains the MSBs, Register #66 contains the LSBs

Bits	[31:0]
Mnemonic	dpll_num

This is a read-only 32bit value that can be used to calculate the sample rate. The raw sample rate (FSR) can be calculated using: $FSR = (DPLL_NUM \times F_{MCLK}) / 2^{32}$.

Note that the DPLL number (register 66-69) should be read from LSB to MSB as it is latched on the LSBs (register 66).

Register #74-70: Channel Status

Register #74 contains the MSBs, Register #70 contains the LSBs Format is [191:0]

These registers allow read back of the SPDIF channel status. The status definition is different for the consumer configuration and professional configuration. Please refer to the following two tables for details.

ES9028Q2M Datasheet



SPDIF CHANNEL STATUS – Consumer configuration								
Address Offset	[7]	[6]	[5]	[4]	[3]	[2]	[1]	[0]
0	Reserved	Reserved	0: 2Channel 1: 4Channel	Reserved	0: No Pre-emph 1: Pre-emphasis	0: CopyRight 1: Non-CopyRight	0: Audio 1: Data	0: Consumer 1: Professional
1	Category Code 0x00: General 0x01: Laser-Optical 0x02: D/D Converter 0x03: Magnetic 0x04: Digital Broadcast 0x05: Musical Instrument 0x06: Present A/D Converter 0x08: Solid State Memory 0x16: Future A/D Converter 0x19: DVD 0x40: Experimental							
2	Channel Number 0x0: Don't Care 0x1: A (Left) 0x2: B (Right) 0x3: C 0x4: D 0x5: E 0x6: F 0x7: G 0x8: H 0x9: I 0xA: J 0xB: K 0xC: L 0xD: M 0xE: N 0xF: O				Source Number 0x0: Don't Care 0x1: 1 0x2: 2 0x3: 3 0x4: 4 0x5: 5 0x6: 6 0x7: G 0x8: 8 0x9: 9 0xA: 10 0xB: 11 0xC: 12 0xD: 13 0xE: 14 0xF: 15			
3	Reserved	Reserved	Clock Accuracy 0x0: Level 2 ±1000ppm 0x1: Level 1 ±50ppm 0x2: Level 3 variable pitch shifted		Sample Frequency 0x0: 44.1k 0x2: 48k 0x3: 32k 0x4: 22.05k 0x6: 24k 0x8: 88.2k 0xA: 96k 0xC: 176.4k 0xE: 192k			
4	Reserved	Reserved	Reserved	Reserved	Word Length: If Word Field Size=0 If Word Field Size = 1 000=Not indicated 000=Not indicated 100 = 23bits 100 = 19bits 010 = 22bits 010 = 18bits 110 = 21bits 110 = 17bits 001 = 20bits 001 = 16bits 101 = 24bits 101 = 20bits			Word Field Size 0: Max 20bits 1: Max 24bits



SPDIF CHANNEL STATUS – Professional configuration							
Address Offset	[7]	[6]	[5]	[4]	[3]	[2]	[1] [0]
0	sampling frequency: 00: not indicated (or see byte 4) 10: 48 kHz 01: 44.1 kHz 11: 32 kHz		lock: 0: locked 1: unlocked	emphasis: 000: Emphasis not indicated 001: No emphasis 011: CD-type emphasis 111: J-17 emphasis		0:Audio 1:Non-audio	0:Consumer 1: Professional
1	User bit management: 0000: no indication 1000: 192-bit block as channel status 0100: As defined in AES18 1100: user-defined 0010: As in IEC60958-3 (consumer)				Channel mode: 0000: not indicated (default to 2 ch) 1000: 2 channel 0100: 1 channel (monophonic) 1100: primary / secondary 0010: stereo 1010: reserved for user applications 0110: reserved for user applications 1110: SCDSR (see byte 3 for ID) 0001: SCDSR (stereo left) 1001: SCDSR (stereo right) 1111: Multichannel (see byte 3 for ID)		
2	alignment level: 00: not indicated 10: –20dB FS 01: –18.06dB FS		Source Word Length: If max = 20bits If max = 24bits 000=Not indicated 000=Not indicated 100 = 23bits 100 = 19bits 010 = 22bits 010 = 18bits 110 = 21bits 110 = 17bits 001 = 20bits 001 = 16bits 101 = 24bits 101 = 20bits		Use of aux sample word: 000: not defined, audio max 20 bits 100: used for main audio, max 24 bits 010: used for coord, audio max 20 bits 110: reserved		
3	Channel identification: if bit 7 = 0 then channel number is 1 plus the numeric value of bits 0-6 (bit reversed). if bit 7 = 1 then bits 4–6 define a multichannel mode and bits 0–3 (bit reversed) give the channel number within that mode.						
4	fs scaling: 0: no scaling 1: apply factor of 1 / 1.001 to value		Sample frequency (fs): 0000: not indicated 0001: 24kHz 0010: 96kHz 1001: 22.05kHz 1010: 88.2kHz 1011: 176.4kHz 0011: 192kHz 1111: User defined		Reserved		DARS (Digital audio reference signal): 00: not a DARS 01: DARS grade 2 (±10ppm) 10: DARS grade 1 (±1ppm) 11: Reserved



RECOMMENDED POWER-UP SEQUENCE

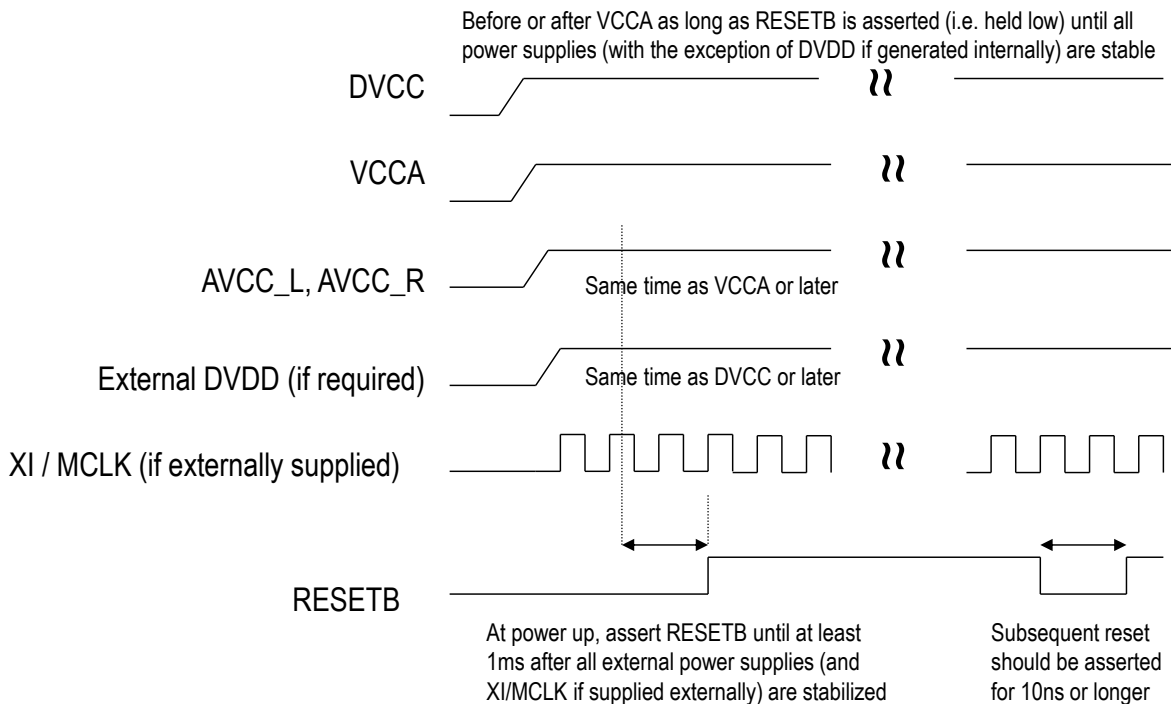



ABSOLUTE MAXIMUM RATINGS

PARAMETER	RATING
Positive Supply Voltage (VCCA, AVCC_L, AVCC_R, DVCC)	+4.7V with respect to GND
Positive Supply Voltage (DVDD)	+1.8V with respect to GND
Output Voltage Range (DACL, DACR, DACLB, DACRB)	GND < Vout < AVCC
Storage Temperature Range	-65°C to +150°C
Operating Junction Temperature	+125°C
Voltage range for Digital Input Pins	-0.3V to DVCC+ 0.3V
ESD Protection	
Human Body Model (HBM)	2000V
Machine Model (MM)	200V
Charged Device Model (CDM)	500V

WARNING: Stresses beyond those listed under “Absolute Maximum Ratings” may cause permanent damage to the device. These are stress ratings only and functional operation of the device at these or any other conditions beyond those indicated under “recommended operating conditions” is not implied. Exposure to absolute–maximum–rated conditions for extended periods may affect device reliability.

WARNING: Electrostatic Discharge (ESD) can damage this device. Proper procedures must be followed to avoid ESD when handling this device.

RECOMMENDED OPERATING CONDITIONS

PARAMETER	SYMBOL	CONDITIONS
Operating temperature	T _A	-20°C to +70°C

Power Supply	Symbol	Voltage	Current nominal (Note 1)	Current standby (Notes 1, 2)
Digital power supply voltage	DVCC	+1.8V ±5% +3.3V ±5%	22mA 23mA	0mA 0mA
Internal Digital Core supply	DVDD	+1.2V (typical)	NA	NA
External Digital Core supply	DVDD	+1.3V ±5% (Note 3)	47mA	0mA
Analog core supply voltage	VCCA	+3.3V ±5%	2mA	0mA
Analog power supply voltage (must be low-noise supplies)	AVCC_L AVCC_R	+3.3V ±5%	11mA	0mA
Total Power		DVCC = +1.8V DVCC = +3.3V	83mW 120mW	< 1mW

Notes

- 1) f_s = 44.1kHz, external MCLK = 40MHz, 0dB 1kHz output, I²S input, output unloaded, internal DVDD, all external supply voltages at nominal center values
- 2) Measured with RESETB held low after setting the soft_start bit in register 14 to 1'b0 to fully ramp the DAC outputs to ground
- 3) Internal DVDD should be used except under the conditions described on page 8. External +1.3V DVDD is required above the operating frequencies described on page 8. The external supply voltage should be greater than the internal +1.2V supply so the internal regulator is disabled. DVDD current is measured with MCLK = 100MHz.

DC ELECTRICAL CHARACTERISTICS

Symbol	Parameter	Minimum	Maximum	Unit	Comments
V _{IH}	High-level input voltage	DVCC / 2 + 0.4		V	
V _{IL}	Low-level input voltage		0.4	V	
V _{OH}	High-level output voltage	DVCC - 0.2		V	I _{OH} = 100μA
V _{OL}	Low-level output voltage		0.2	V	I _{OL} = 100μA

ES9028Q2M Datasheet



XI / MCLK Timing

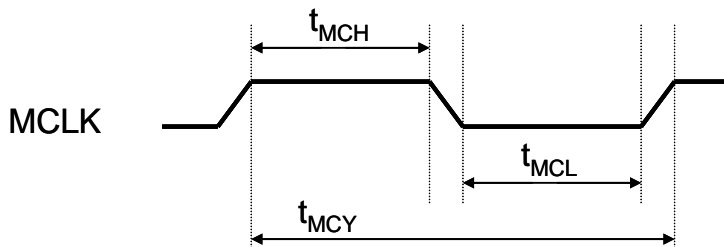

Parameter	Symbol	Min	Max	Unit
MCLK pulse width high	T_{MCH}	4.5		ns
MCLK pulse width low	T_{MCL}	4.5		ns
MCLK cycle time	T_{MCY}	10		ns
MCLK duty cycle		45:55	55:45	

Audio Interface Timing

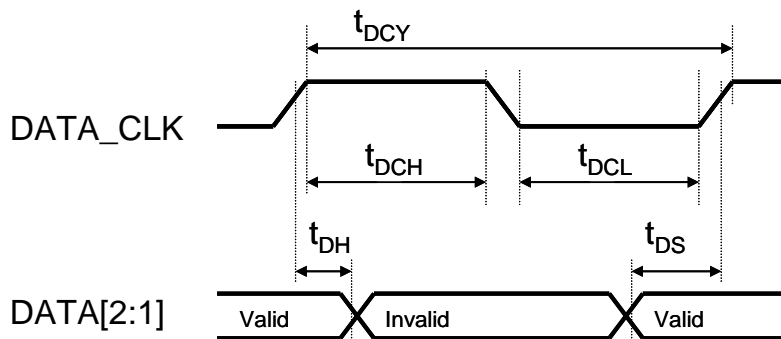

Parameter	Symbol	Min	Max	Unit
DATA_CLK pulse width high	t_{DCH}	4.5		ns
DATA_CLK pulse width low	t_{DCL}	4.5		ns
DATA_CLK cycle time	t_{DCY}	10		ns
DATA_CLK duty cycle		45:55	55:45	
DATA set-up time to DATA_CLK rising edge	t_{DS}	4.1		ns
DATA hold time to DATA_CLK rising edge	t_{DH}	2		ns

Notes:

- Audio data on DATA[2:1] are sampled at the rising edges of DATA_CLK and must satisfy the setup and hold time requirements relative to the rising edge of DATA_CLK
- For DSD Phase mode, the normal data (D0, D1, D2... on p.10) must satisfy the setup and hold time requirements relative to the rising edge of DATA_CLK. The complimentary data ($\bar{D}0$, $\bar{D}1$, etc.) will be ignored.



ANALOG PERFORMANCE

Test Conditions (unless otherwise stated)

- $T_A = 25^\circ\text{C}$, $AVCC = VCCA = DVCC = +3.3\text{V}$, internal DVDD with $4.7\mu\text{F} \pm 20\%$ decoupling, $f_s = 44.1\text{kHz}$, $MCLK = 27\text{MHz}$ & 32-bit data
- SNR/DNR: A-weighted over 20Hz-20kHz in averaging mode
THD+N: un-weighted over 20Hz-20kHz bandwidth

PARAMETER	CONDITIONS	MIN	TYP	MAX	UNIT
Resolution			32		Bits
MCLK (PCM normal mode)	Note 3	192FSR		Note 2	Hz
MCLK (PCM OSF bypass mode)		24FSR			
MCLK (DSD mode)		3FSR			
MCLK (SPDIF mode)		386FSR			
DYNAMIC PERFORMANCE					
DNR (differential current mode)	-60dBFS		129		dB-A
THD+N (differential current mode)	0dBFS		-120		dB
ANALOG OUTPUT					
Differential (+ or -) voltage output range	Full-scale out		$0.867 \times AVCC$		Vp-p
Differential (+ or -) voltage output offset	Bipolar zero out		$AVCC / 2$		V
Differential (+ or -) current output range (Note 1)	Full-scale out		$0.867 \times AVCC / 403$		mA _{p-p}
Differential (+ or -) current output offset (Note 1)	Bipolar zero out to virtual ground at voltage V_g (V)		$1000 / 403 \times (AVCC / 2 - V_g)$		mA
Digital Filter Performance					
De-emphasis error				± 0.2	dB
Mute Attenuation			-127		dB
PCM Filter Characteristics (Sharp Roll Off)					
Pass band	$\pm 0.003\text{dB}$			0.454fs	Hz
	-3dB			0.49fs	Hz
Stop band	< -115dB	0.546fs			Hz
Group Delay			35 / fs		s
PCM Filter Characteristics (Slow Roll Off)					
Pass band	$\pm 0.05\text{dB}$			0.308fs	Hz
	-3dB			0.454fs	Hz
Stop band	< -100dB	0.814fs			Hz
Group Delay			6.25 / fs		s
PCM Filter Characteristics (Minimum Phase)					
Pass band	$\pm 0.003\text{dB}$			0.454fs	Hz
	-3dB			0.49fs	Hz
Stop band	< -115dB	0.546fs			Hz

Notes

- Differential (+ or -) current output is equivalent to a differential (+ or -) voltage source in series with a $403\Omega \pm 11\%$ resistor. The differential (+ or -) voltage source has a peak-to-peak output range of $(0.867 \times AVCC)$ & an output offset of $(AVCC / 2)$.
- With internal DVDD, maximum MCLK frequency is 50MHz ($DVCC = +1.8\text{V}$).
MCLK can be up to 100MHz ($DVCC = +3.3\text{V}$) using an external $+1.3\text{V} \pm 5\%$ DVDD supply.
- ES9028Q2M also supports synchronous MCLK at $128 \times \text{FSR}$.

ES9028Q2M Datasheet



PCM DE-EMPHASIS FILTER RESPONSE (32kHz)

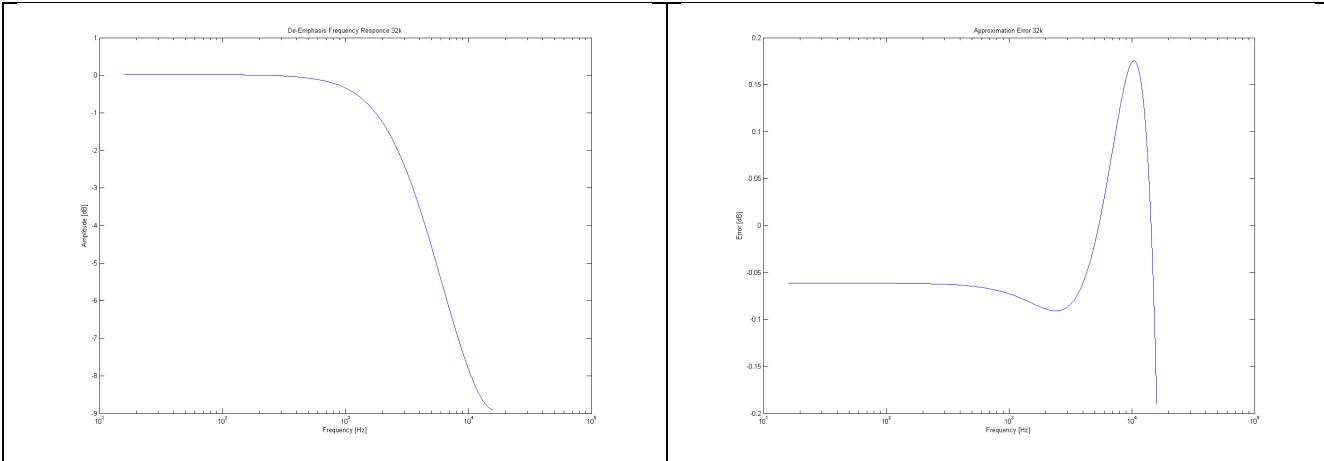

PCM DE-EMPHASIS FILTER RESPONSE (44.1kHz)

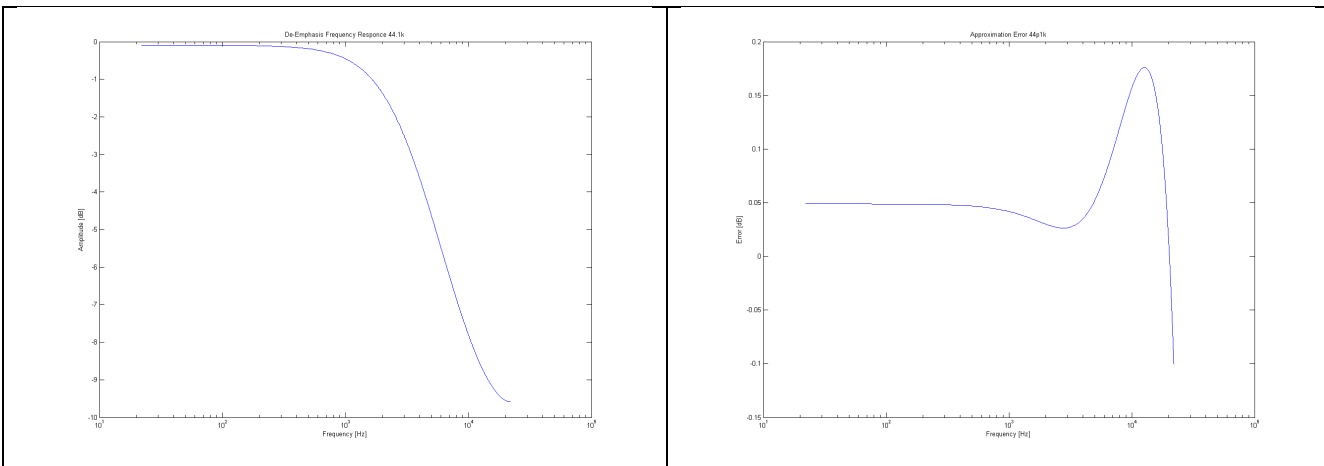

PCM DE-EMPHASIS FILTER RESPONSE (48kHz)

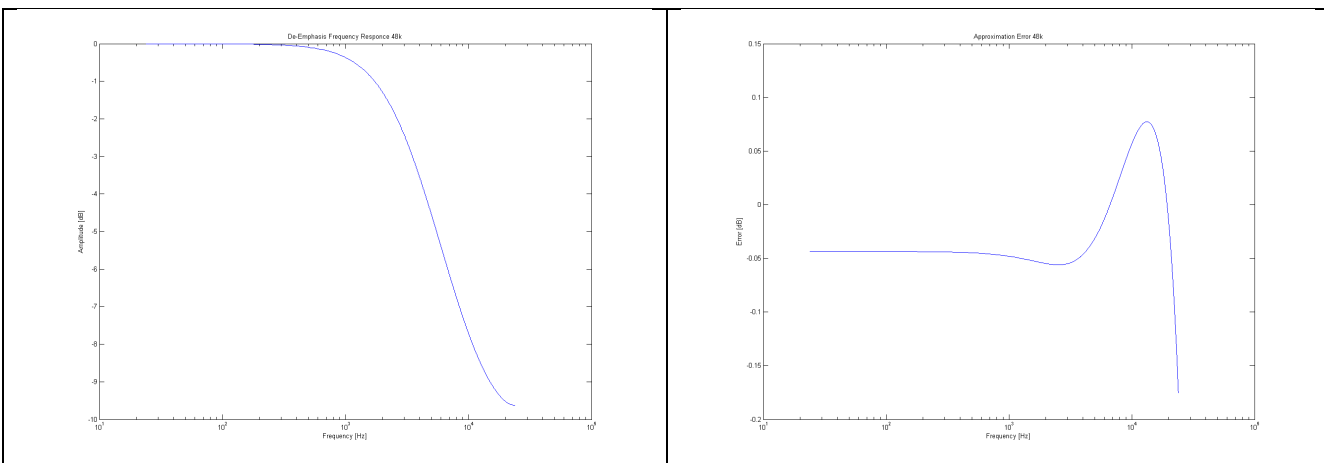



PCM FILTER FREQUENCY RESPONSE

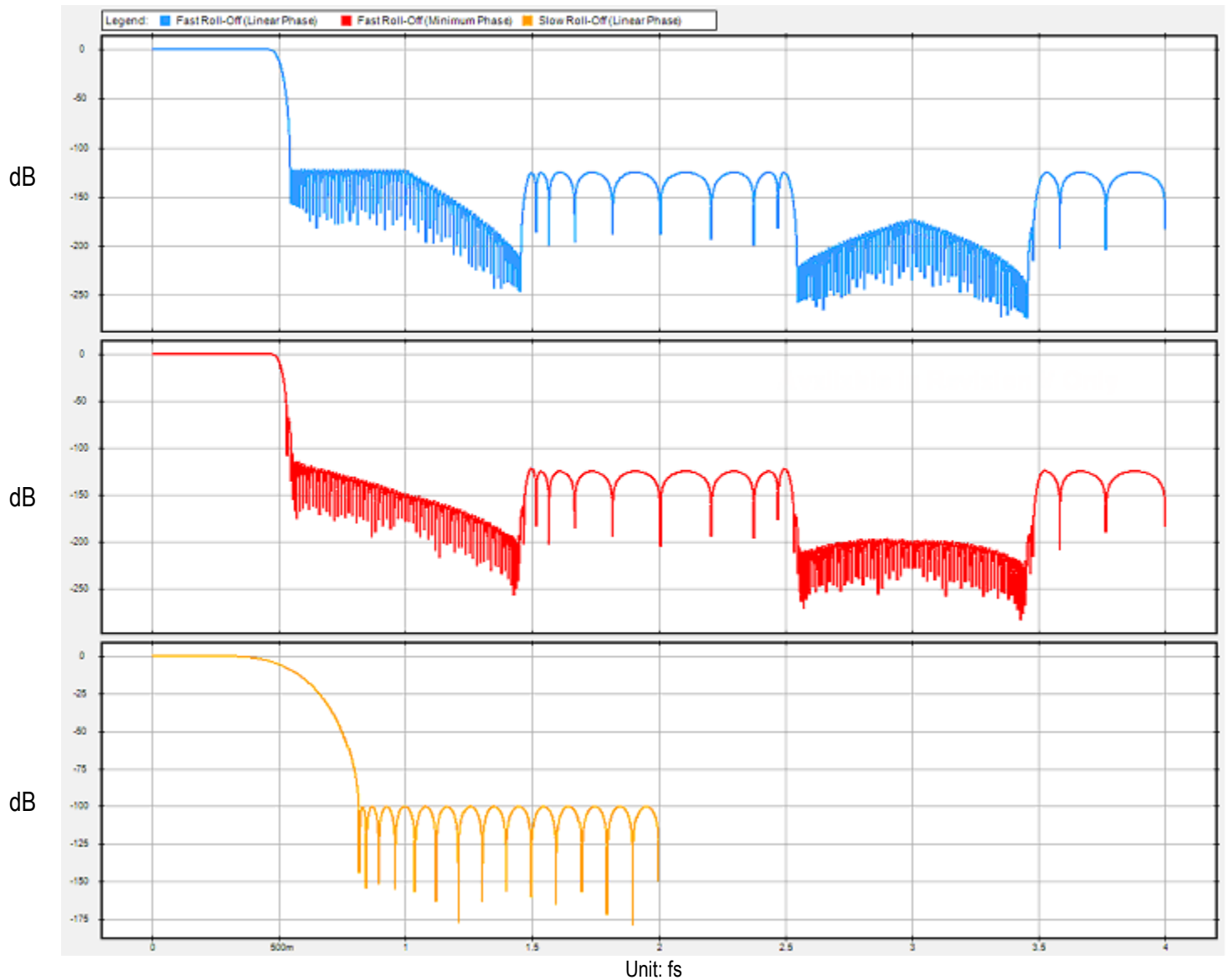

PCM FILTER IMPULSE RESPONSE

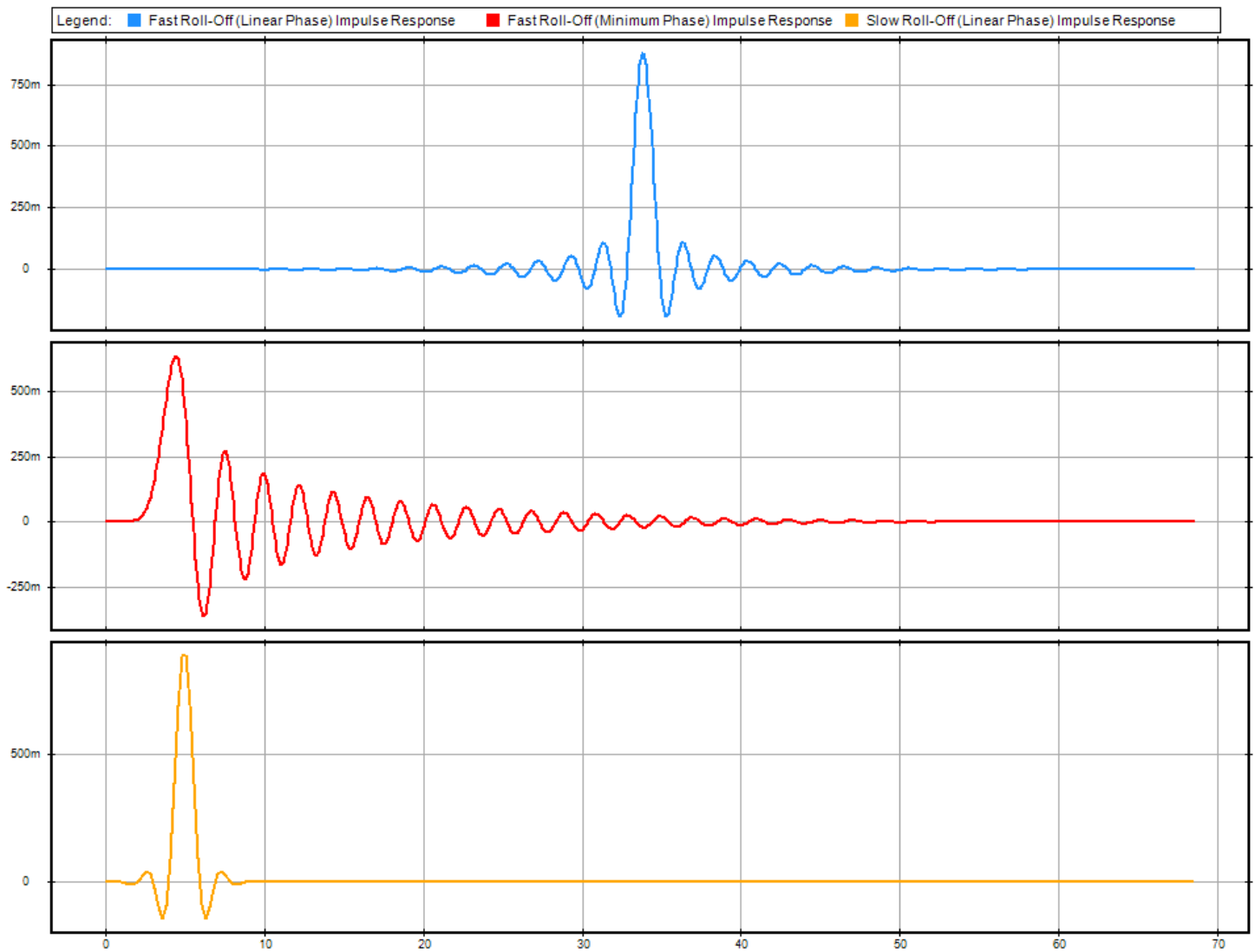

Unit: 1/fs (s)



DSD FILTER RESPONSE

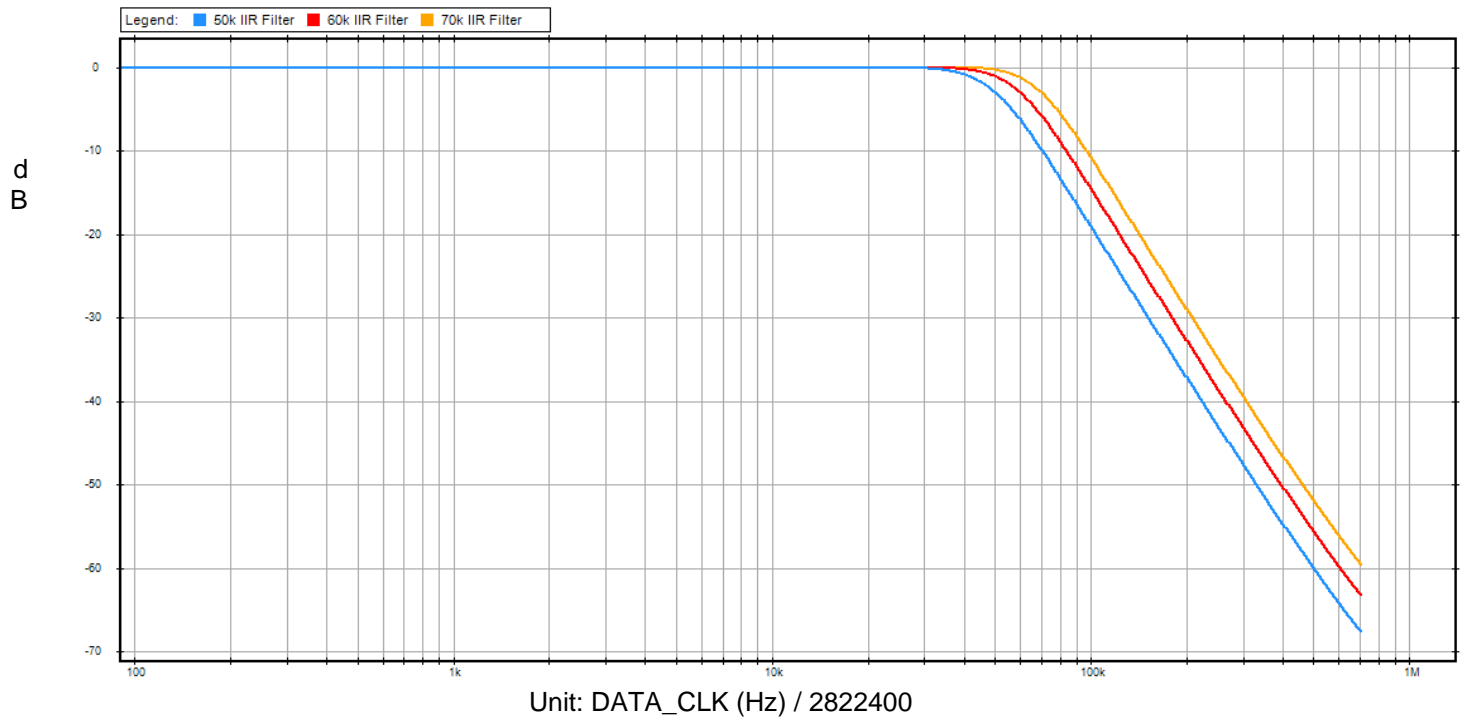

ES9028Q2M Datasheet



Figure 4. ES9028Q2M Reference Design

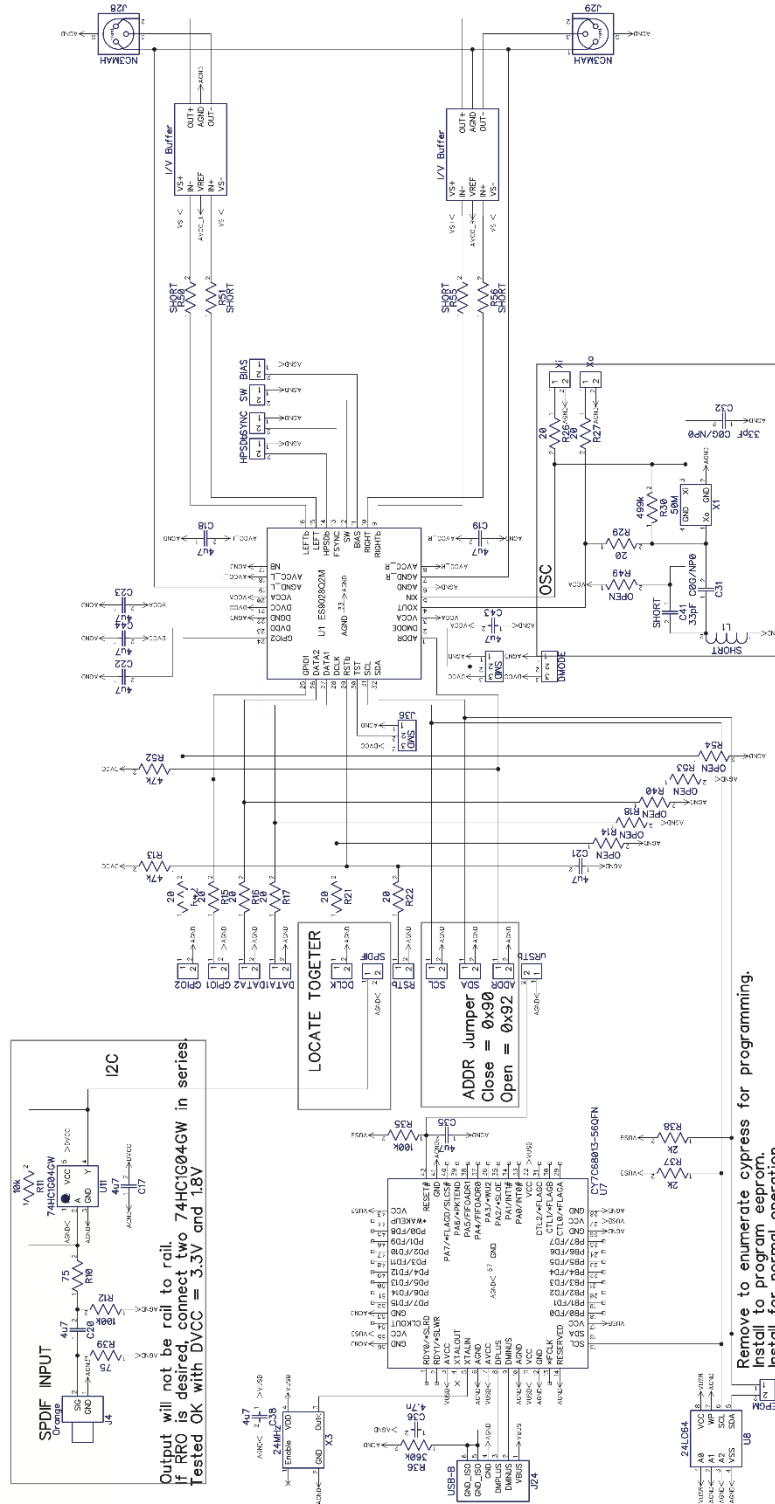

This topology supports fundamental and 3rd overtone crystals as well as oscillators. Short and open components as needed to accommodate different crystals and oscillators. Use 4-SMD 3.2 X 2.5mm package or compatible.



Figure 5. Current-to-Voltage Converter, DC blocking, & Low-Pass Filter for each Output Channel of the ES9028Q2M

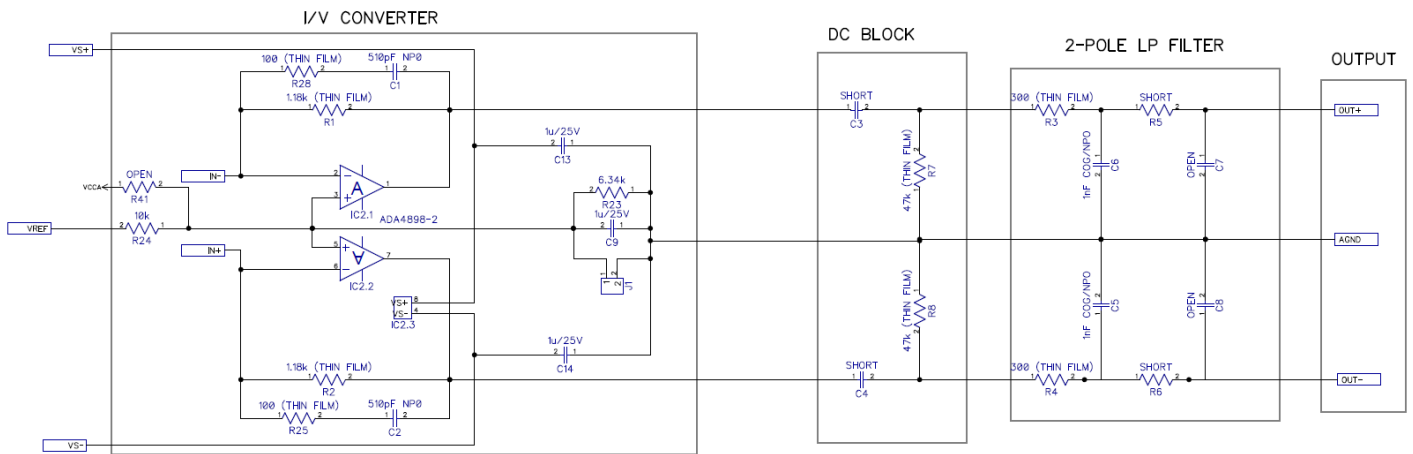
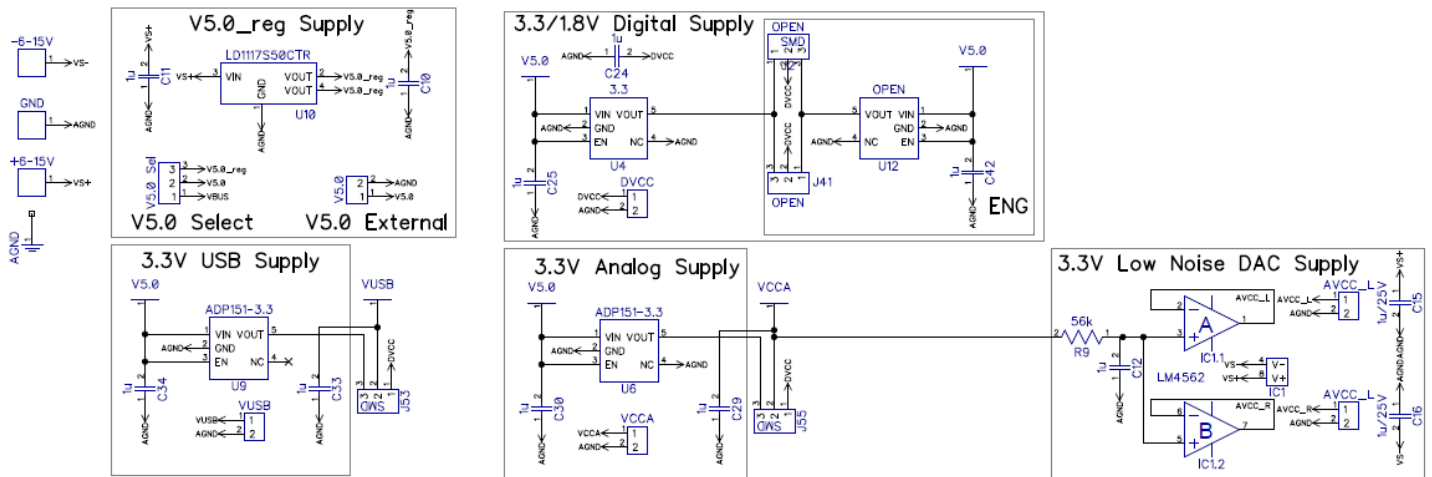

Figure 6. ES9028Q2M Reference Design Power Supplies



ES9028Q2M Datasheet



32-Pin QFN Mechanical Dimensions

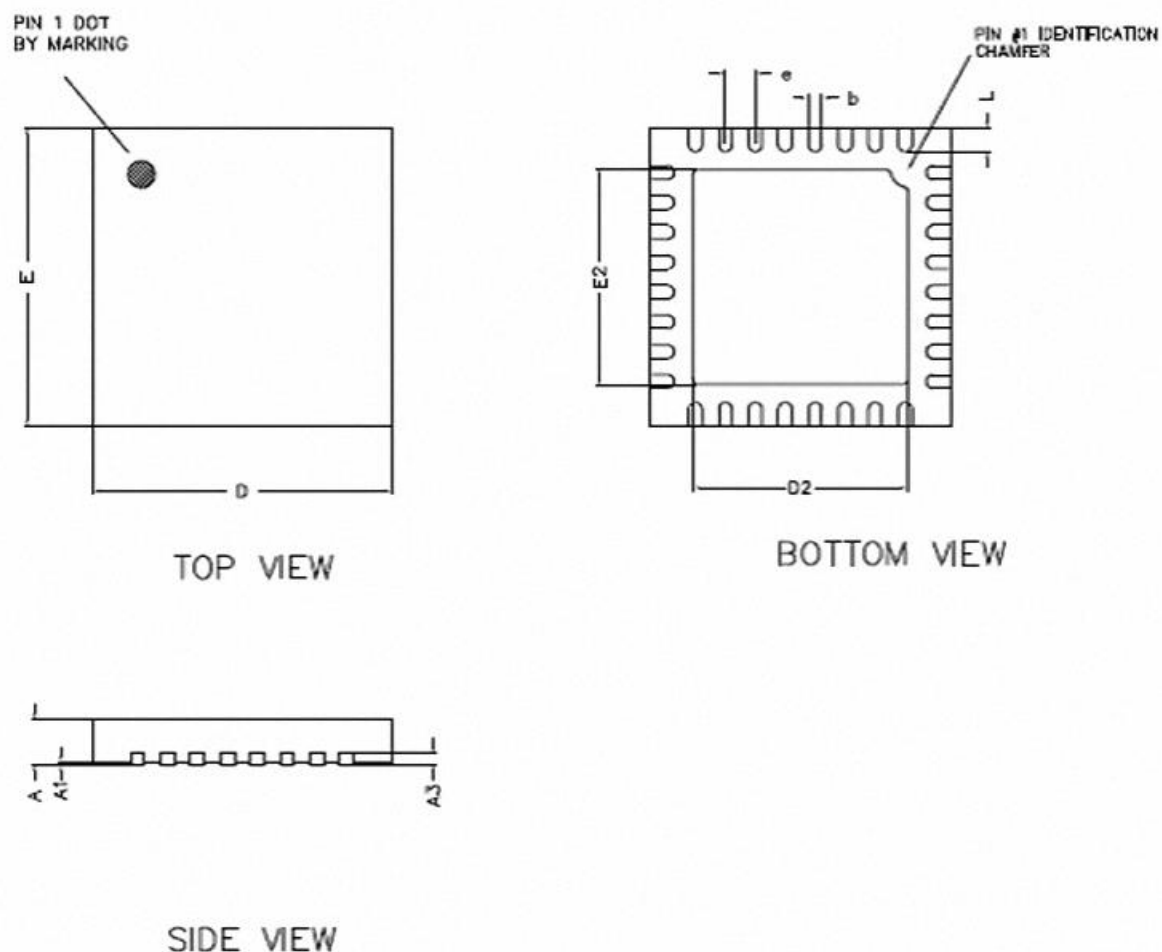

COMMON DIMENSIONS (mm)			
PKG.	VERY VERY THIN		
REF.	MIN.	NOM.	MAX.
A	0.70	0.80	0.90
A1	0.00	0.02	0.05
A3	0.2 REF.		
D	4.95	5.00	5.05
E	4.95	5.00	5.05
b	0.18	0.25	0.30
L	0.30	0.40	0.50
D2	3.35	3.50	3.70
E2	3.35	3.50	3.70
e	0.5 BSC		



Example 32-Pin QFN Land Pattern

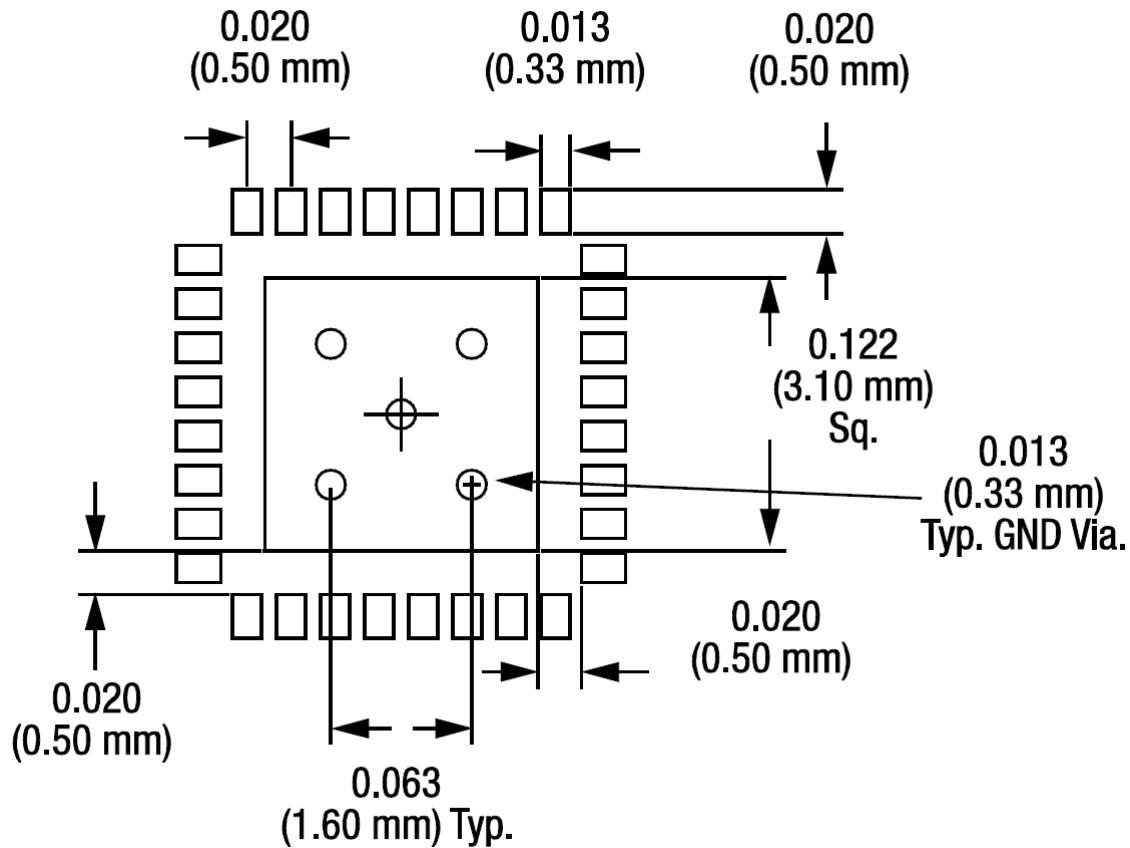

Notes:

1. Thermal vias should be 0.3mm to 0.33mm in diameter, with the barrel plated to 1oz copper.
2. For maximum solder mask in the corners, round the inner corners of each row.
3. Exposed pad should be solder mask defined.
4. Pad width can be reduced to 0.25mm if additional pad to pad clearance is required.
5. For applications where solder loss through vias is a concern, plugging or tenting of the vias should be used. The solder mask diameter for each via should be 0.1mm larger than the via diameter.

Reflow Process Considerations

For lead-free soldering, the characterization and optimization of the reflow process is the most important factor you need to consider.

The lead-free alloy solder has a melting point of 217°C. This alloy requires a minimum reflow temperature of 235°C to ensure good wetting. The maximum reflow temperature is in the 245°C to 260°C range, depending on the package size (*Table RPC-2*). This narrows the process window for lead-free soldering to 10°C to 20°C.

The increase in peak reflow temperature in combination with the narrow process window makes the development of an optimal reflow profile a critical factor for ensuring a successful lead-free assembly process. The major factors contributing to the development of an optimal thermal profile are the size and weight of the assembly, the density of the components, the mix of large and small components, and the paste chemistry being used.

Reflow profiling needs to be performed by attaching calibrated thermocouples well adhered to the device as well as other critical locations on the board to ensure that all components are heated to temperatures above the minimum reflow temperatures and that smaller components do not exceed the maximum temperature limits (*Table RPC-2*).

To ensure that all packages can be successfully and reliably assembled, the reflow profiles studied and recommended by ESS are based on the JEDEC/IPC standard J-STD-020 revision D.1.

Figure RPC-1. IR/Convection Reflow Profile (IPC/JEDEC J-STD-020D.1)

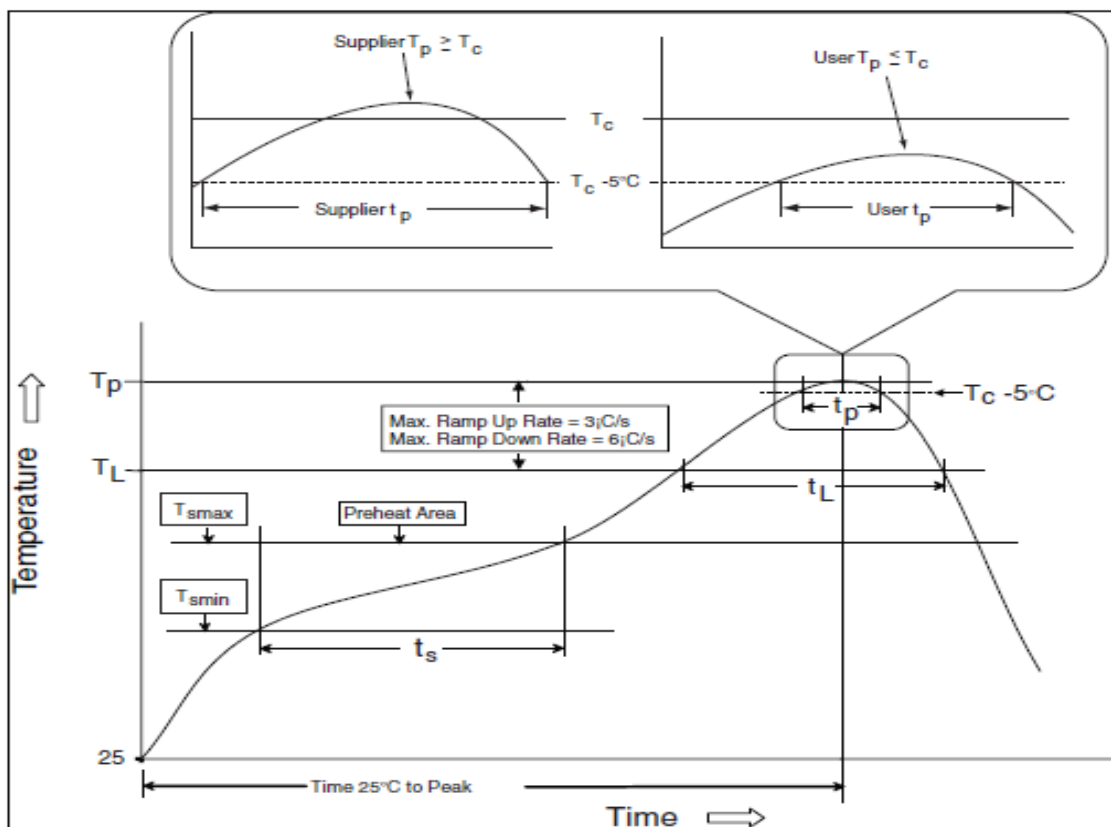

Note: Reflow is allowed 3 times. Caution must be taken to ensure time between re-flow runs does not exceed the allowed time by the moisture sensitivity label. If the time elapsed between the re-flows exceeds the moisture sensitivity time bake the board according to the moisture sensitivity label instructions.

Manual Soldering:

Allowed up to 2 times with maximum temperature of 350 degrees no longer than 3 seconds.



Table RPC-1 Classification reflow profile

Profile Feature	Pb-Free Assembly
Preheat/Soak Temperature Min (T _{smin}) Temperature Max (T _{smax}) Time (ts) from (T _{smin} to T _{smax})	150°C 200°C 60-120 seconds
Ramp-up rate (TL to T _p)	3°C / second max.
Liquidous temperature (TL) Time (t _L) maintained above TL	217°C 60-150 seconds
Peak package body temperature (T _p)	For users T _p must not exceed the classification temp in Table RPC-2. For suppliers T _p must equal or exceed the Classification temp in Table RPC-2.
Time (t _p)* within 5°C of the specified classification temperature (T _c), see Figure RPC-1	30* seconds
Ramp-down rate (T _p to TL)	6°C / second max.
Time 25°C to peak temperature	8 minutes max.
* Tolerance for peak profile temperature (T _p) is defined as a supplier minimum and a user maximum.	

- Note 1:** All temperatures refer to the center of the package, measured on the package body surface that is facing up during assembly reflow (e.g., live-bug). If parts are reflowed in other than the normal live-bug assembly reflow orientation (i.e., dead-bug), T_p **shall** be within ±2°C of the live-bug T_p and still meet the T_c requirements, otherwise, the profile **shall** be adjusted to achieve the latter. To accurately measure actual peak package body temperatures refer to JEP140 for recommended thermocouple use.
- Note 2:** Reflow profiles in this document are for classification/preconditioning and are not meant to specify board assembly profiles. Actual board assembly profiles should be developed based on specific process needs and board designs and should not exceed the parameters in Table RPC-1. For example, if T_c is 260°C and time t_p is 30 seconds, this means the following for the supplier and the user.
For a supplier: The peak temperature must be at least 260°C. The time above 255°C must be at least 30 seconds.
For a user: The peak temperature must not exceed 260°C. The time above 255°C must not exceed 30 seconds.
- Note 3:** All components in the test load **shall** meet the classification profile requirements.

Table RPC-2 Pb-Free Process – Classification Temperatures (T_c)

Package Thickness	Volume mm ³ , <350	Volume mm ³ , 350 to 2000	Volume mm ³ , >2000
<1.6 mm	260°C	260°C	260°C
1.6 mm – 2.5 mm	260°C	250°C	245°C
>2.5 mm	250°C	245°C	245°C

- Note 1:** At the discretion of the device manufacturer, but not the board assembler/user, the maximum peak package body temperature (T_p) can exceed the values specified in Table RPC-2. The use of a higher T_p does not change the classification temperature (T_c).
- Note 2:** Package volume excludes external terminals (e.g., balls, bumps, lands, leads) and/or non-integral heat sinks.
- Note 3:** The maximum component temperature reached during reflow depends on package thickness and volume. The use of convection reflow processes reduces the thermal gradients between packages. However, thermal gradients due to differences in thermal mass of SMD packages may still exist.

ES9028Q2M Datasheet



ORDERING INFORMATION

Part Number	Description	Package
ES9028Q2M	Sabre ³² Reference 32-Bit, 2-Channel, Mobile Low Power DAC	32-pin QFN

The letter Q identifies the package type QFN

Revision History

Rev.	Date	Notes
0.1	July 1, 2015	Initial release
0.1a	August 27, 2015	Update recommended power supply sequence
0.2	November 24, 2015	Update package dimensions Add CDM to Absolute Maximum Ratings
0.21	March 16, 2016	Cleanup of typos and formatting
0.3	November, 28, 2017	Remove ESS Logo from pin diagram
0.4	November 15, 2018	Added Low Power Audio DAC description, removed Advanced Information
0.41	January 16, 2020	Correct typo register setting for Master Clock enable to Register #10

ESS IC's are not intended, authorized, or warranted for use as components in military applications, medical devices or life support systems. ESS assumes no liability whatsoever and disclaims any expressed, implied or statutory warranty for use of ESS IC's in such unsuitable applications.

No part of this publication may be reproduced, stored in a retrieval system, transmitted, or translated in any form or by any means, electronic, mechanical, manual, optical, or otherwise, without the prior written permission of ESS Technology, Inc. ESS Technology, Inc. makes no representations or warranties regarding the content of this document. All specifications are subject to change without prior notice. ESS Technology, Inc. assumes no responsibility for any errors contained herein. U.S. patents pending.

Looking for pricing, stock, or lifecycle information?

Click below to explore more details on WIN SOURCE:

 [View ES9028Q2M on WIN SOURCE](#)

 [ESS Technology Information](#)

Optimize Your Supply Chain with WIN SOURCE Solutions

-  Global Sourcing Solution
-  Obsolete Management
-  Cost Control Management
-  Shortage Management
-  Alternative Solution
-  Excess Inventory Management