



**THE DATASHEET OF  
HA3-5320-5**



HA-5320

1 Microsecond Precision Sample and Hold Amplifier

FN2857  
Rev 10.00  
August 11, 2015

The HA-5320 was designed for use in precision, high speed data acquisition systems.

The circuit consists of an input transconductance amplifier capable of providing large amounts of charging current, a low leakage analog switch, and an output integrating amplifier. The analog switch sees virtual ground as its load; therefore, charge injection on the hold capacitor is constant over the entire input/output voltage range. The pedestal voltage resulting from this charge injection can be adjusted to zero by use of the offset adjust inputs. The device includes a hold capacitor. However, if improved droop rate is required at the expense of acquisition time, additional hold capacitance may be added externally.

This monolithic device is manufactured using the Intersil Dielectric Isolation Process, minimizing stray capacitance and eliminating SCRs. This allows higher speed and latch-free operation. For further information, please see Application Note AN538.

Pinouts

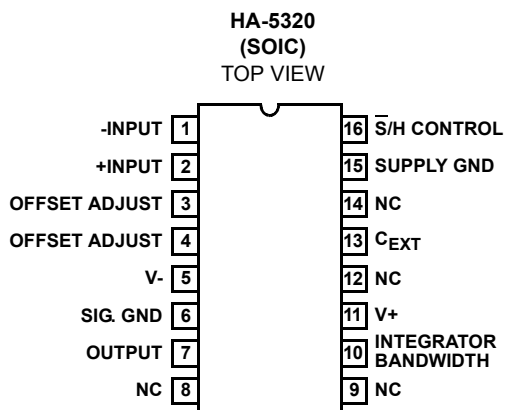
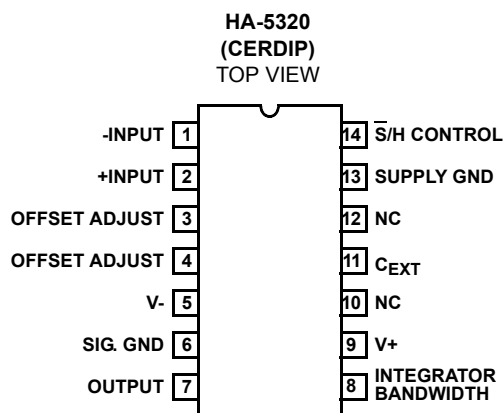

Features

- Gain, DC .....  $2 \times 10^6$  V/V
- Acquisition Time ..... 1.0μs (0.01%)
- Droop Rate ..... 0.08μV/μs (+25°C)  
17μV/μs (Full Temperature)
- Aperture Time ..... 25ns
- Hold Step Error (See Glossary) ..... 5mV
- Internal Hold Capacitor
- Fully Differential Input
- TTL Compatible
- Pb-Free Available (RoHS Compliant)

Applications

- Precision Data Acquisition Systems
- Digital to Analog Converter Deglitcher
- Auto Zero Circuits
- Peak Detector

Ordering Information

PART NUMBER (Note 2)	PART MARKING	TEMP. RANGE (°C)	PACKAGE	PKG. DWG. #
HA1-5320-2	HA1-5320-2	-55 to +125	14 Ld CERDIP	F14.3
HA9P5320-5Z (Note 1)	HA9P5320-5Z	0 to +75	16 Ld SOIC (Pb-free)	M16.3

NOTES:

1. Add X96 for Tape and Reel.
2. Intersil Pb-free plus anneal products employ special Pb-free material sets; molding compounds/die attach materials and 100% matte tin plate termination finish, which are RoHS compliant and compatible with both SnPb and Pb-free soldering operations. Intersil Pb-free products are MSL classified at Pb-free peak reflow temperatures that meet or exceed the Pb-free requirements of IPC/JEDEC J STD-020.

### Functional Diagram

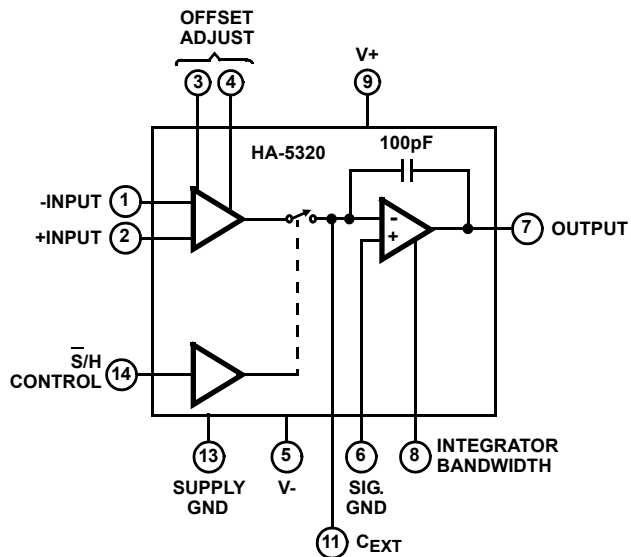

**Absolute Maximum Ratings**

Supply Voltage	.....40V
Differential Input Voltage	.....24V
Digital Input Voltage	..... +8V, -15V
Output Current, Continuous (Note 1)	..... ±20mA

**Operating Conditions**

Temperature Range	
HA-5320-2	..... -55°C to 125°C
HA-5320-5	..... 0°C to 75°C
Supply Voltage Range (Typical, Note 2)	..... ±13.5V to ±20V

**Thermal Information**

Thermal Resistance (Typical, Note 5)	$\theta_{JA}$ (°C/W)	$\theta_{JC}$ (°C/W)
CERDIP Package	..... 70	..... 18
SOIC Package	..... 90	..... N/A
Maximum Junction Temperature (Ceramic Package)	..... 175°C	
Maximum Junction Temperature (Plastic Package)	..... 150°C	
Maximum Storage Temperature Range	..... -65°C to 150°C	
Maximum Lead Temperature (Soldering 10s)	..... 300°C (SOIC - Lead Tips Only)	
Pb-Free Reflow Profile	see link below	
	<a href="http://www.intersil.com/pbfree/Pb-FreeReflow.asp">http://www.intersil.com/pbfree/Pb-FreeReflow.asp</a>	

**CAUTION:** Stresses above those listed in "Absolute Maximum Ratings" may cause permanent damage to the device. This is a stress only rating and operation of the device at these or any other conditions above those indicated in the operational sections of this specification is not implied.

**NOTES:**

- Internal Power Dissipation may limit Output Current below 20mA.
- Specification based on a one time characterization. This parameter is not guaranteed.
- $\theta_{JA}$  is measured with the component mounted on an evaluation PC board in free air.

**Electrical Specifications**  $V_{SUPPLY} = \pm 15.0V$ ;  $C_H = \text{Internal}$ ; Digital Input:  $V_{IL} = +0.8V$  (Sample),  $V_{IH} = +2.0V$  (Hold), Unity Gain Configuration (Output tied to -Input), Unless Otherwise Specified

PARAMETER	TEST CONDITIONS	TEMP. (°C)	HA-5320-2			HA-5320-5			UNITS
			MIN	TYP	MAX	MIN	TYP	MAX	
<b>INPUT CHARACTERISTICS</b>									
Input Voltage Range		Full	±10	-	-	±10	-	-	V
Input Resistance		25	1	5	-	1	5	-	MΩ
Input Capacitance		25	-	-	5	-	-	5	pF
Offset Voltage		25	-	0.2	-	-	0.5	-	mV
		Full	-	-	2.0	-	-	1.5	mV
Bias Current		25	-	70	200	-	100	300	nA
		Full	-	-	200	-	-	300	nA
Offset Current		25	-	30	100	-	30	300	nA
		Full	-	-	100	-	-	300	nA
Common Mode Range		Full	±10	-	-	±10	-	-	V
CMRR	$V_{CM} = \pm 5V$	25	80	90	-	72	90	-	dB
Offset Voltage Temperature Coefficient		Full	-	5	15	-	5	20	μV/°C
<b>TRANSFER CHARACTERISTICS</b>									
Gain	DC, (Note 14)	25	$10^6$	$2 \times 10^6$	-	$3 \times 10^5$	$2 \times 10^6$	-	V/V
Gain Bandwidth Product ( $A_V = +1$ , Note 7)	$C_H = 100pF$	25	-	2.0	-	-	2.0	-	MHz
	$C_H = 1000pF$	25	-	0.18	-	-	0.18	-	MHz
<b>OUTPUT CHARACTERISTICS</b>									
Output Voltage		Full	±10	-	-	±10	-	-	V
Output Current		25	±10	-	-	±10	-	-	mA
Full Power Bandwidth	Note 6	25	-	600	-	-	600	-	kHz
Output Resistance	Hold Mode	25	-	1.0	-	-	1.0	-	Ω
Total Output Noise (DC to 10MHz)	Sample	25	-	125	200	-	125	200	μV <sub>RMS</sub>
	Hold	25	-	125	200	-	125	200	μV <sub>RMS</sub>

**Electrical Specifications**  $V_{SUPPLY} = \pm 15.0V$ ;  $C_H = \text{Internal}$ ; Digital Input:  $V_{IL} = +0.8V$  (Sample),  $V_{IH} = +2.0V$  (Hold), Unity Gain Configuration (Output tied to -Input), Unless Otherwise Specified **(Continued)**

PARAMETER	TEST CONDITIONS	TEMP. (°C)	HA-5320-2			HA-5320-5			UNITS
			MIN	TYP	MAX	MIN	TYP	MAX	
<b>TRANSIENT RESPONSE</b>									
Rise Time	Note 7	25	-	100	-	-	100	-	ns
Overshoot	Note 7	25	-	15	-	-	15	-	%
Slew Rate	Note 8	25	-	45	-	-	45	-	V/ $\mu$ s
<b>DIGITAL INPUT CHARACTERISTICS</b>									
Input Voltage	$V_{IH}$	Full	2.0	-	-	2.0	-	-	V
	$V_{IL}$	Full	-	-	0.8	-	-	0.8	V
Input Current	$V_{IL} = 0V$	25	-	-	4	-	-	4	$\mu$ A
		Full	-	-	10	-	-	10	$\mu$ A
	$V_{IH} = +5V$	Full	-	-	0.1	-	-	0.1	$\mu$ A
<b>SAMPLE AND HOLD CHARACTERISTICS</b>									
Acquisition Time (Note 9)	To 0.1%	25	-	0.8	1.2	-	0.8	1.2	$\mu$ s
	To 0.01%	25	-	1.0	1.5	-	1.0	1.5	$\mu$ s
Aperture Time (Note 10)		25	-	25	-	-	25	-	ns
Effective Aperture Delay Time		25	-50	-25	0	-50	-25	0	ns
Aperture Uncertainty		25	-	0.3	-	-	0.3	-	ns
Droop Rate		25	-	0.08	0.5	-	0.08	0.5	$\mu$ V/ $\mu$ s
		Full	-	17	100	-	1.2	100	$\mu$ V/ $\mu$ s
Drift Current	Note 11	25	-	8	50	-	8	50	pA
		Full	-	1.7	10	-	0.12	10	nA
Charge Transfer	Note 11	25	-	0.5	1.1	-	0.5	1.1	pC
Hold Step Error	Note 11	25	-	5	11	-	5	11	mV
Hold Mode Settling Time	To 0.01%	Full	-	165	350	-	165	350	ns
Hold Mode Feedthrough	10V <sub>P-P</sub> , 100kHz	Full	-	2	-	-	2	-	mV
<b>POWER SUPPLY CHARACTERISTICS</b>									
Positive Supply Current	Note 12	25	-	11	13	-	11	13	mA
Negative Supply Current	Note 12	25	-	-11	-13	-	-11	-13	mA
Supply Voltage Range	Note 4		$\pm 13.5$	-	$\pm 20$	$\pm 13.5$	-	$\pm 20$	V
Power Supply Rejection	V+, Note 13	Full	80	-	-	80	-	-	dB
	V-, Note 13	Full	65	-	-	65	-	-	dB

## NOTES:

- $V_O = 20V_{P-P}$ ;  $R_L = 2k\Omega$ ;  $C_L = 50pF$ ; unattenuated output.
- $V_O = 200mV_{P-P}$ ;  $R_L = 2k\Omega$ ;  $C_L = 50pF$ .
- $V_O = 20V$  Step;  $R_L = 2k\Omega$ ;  $C_L = 50pF$ .
- $V_O = 10V$  Step;  $R_L = 2k\Omega$ ;  $C_L = 50pF$ .
- Derived from computer simulation only; not tested.
- $V_{IN} = 0V$ ,  $V_{IH} = +3.5V$ ,  $t_R < 20ns$  ( $V_{IL}$  to  $V_{IH}$ ).
- Specified for a zero differential input voltage between +IN and -IN. Supply current will increase with differential input (as may occur in the Hold mode) to approximately  $\pm 46mA$  at 20V.
- Based on a 1V delta in each supply, i.e.  $15V \pm 0.5V_{DC}$ .
- $R_L = 1k\Omega$ ,  $C_L = 30pF$ .

## Test Circuits and Waveforms

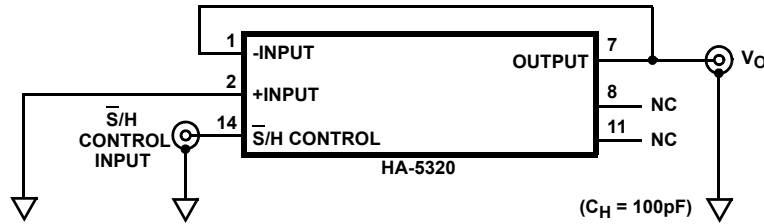
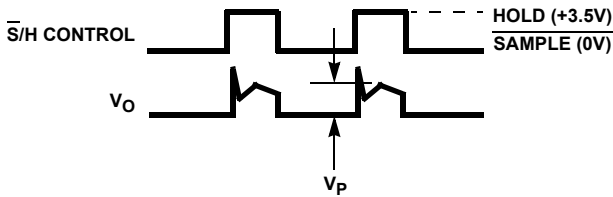

FIGURE 1. CHARGE TRANSFER AND DRIFT CURRENT



NOTES:

15. Observe the “hold step” voltage  $V_P$ .
16. Compute charge transfer:  $Q = V_P C_H$ .

FIGURE 2. CHARGE TRANSFER TEST

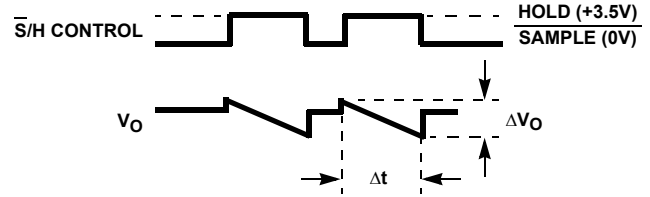

NOTES:

17. Observe the voltage “droop”,  $\Delta V_O/\Delta t$ .
18. Measure the slope of the output during hold,  $\Delta V_O/\Delta t$ , and compute drift current:  $I_D = C_H \Delta V_O/\Delta t$ .

FIGURE 3. DRIFT CURRENT TEST

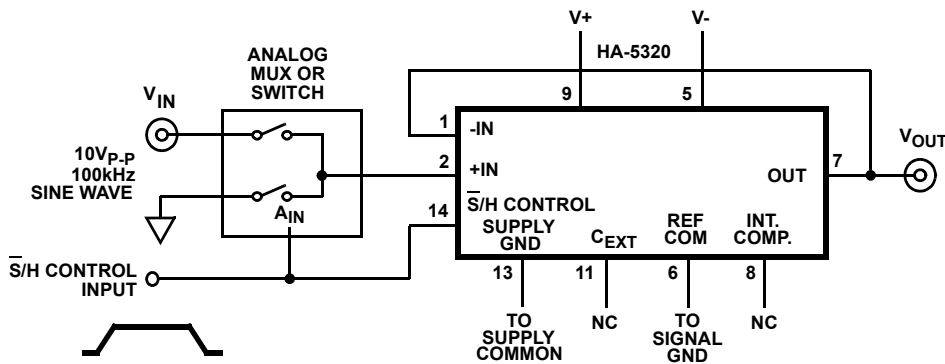

NOTE:

Feedthrough in

$$dB = 20 \log \frac{V_{OUT}}{V_{IN}} \quad \text{where:}$$

$$V_{OUT} = V_{P-P, \text{ Hold Mode}}, V_{IN} = V_{P-P}$$

FIGURE 4. HOLD MODE FEEDTHROUGH ATTENUATION

### Application Information

The HA-5320 has the uncommitted differential inputs of an op amp, allowing the Sample and Hold function to be combined with many conventional op amp circuits. See the Intersil Application Note AN517 for a collection of circuit ideas.

### Layout

A printed circuit board with ground plane is recommended for best performance. Bypass capacitors (0.01 $\mu$ F to 0.1 $\mu$ F, ceramic) should be provided from each power supply terminal to the Supply Ground terminal on pin 13.

The ideal ground connections are pin 6 (SIG. Ground) directly to the system Signal Ground, and pin 13 (Supply Ground) directly to the system Supply Common.

### Hold Capacitor

The HA-5320 includes a 100pF MOS hold capacitor, sufficient for most high speed applications (the Electrical Specifications section is based on this internal capacitor).

Additional capacitance may be added between pins 7 and 11. This external hold capacitance will reduce droop rate at the expense of acquisition time, and provide other trade-offs as shown in the Performance Curves.

If an external hold capacitor  $C_{EXT}$  is used, then a noise bandwidth capacitor of value  $0.1C_{EXT}$  should be connected from pin 8 to ground. Exact value and type are not critical.

The hold capacitor  $C_{EXT}$  should have high insulation resistance and low dielectric absorption, to minimize droop errors. Polystyrene dielectric is a good choice for operating temperatures up to +85°C. Teflon® and glass dielectrics offer good performance to +125°C and above.



**Typical Performance Curves**

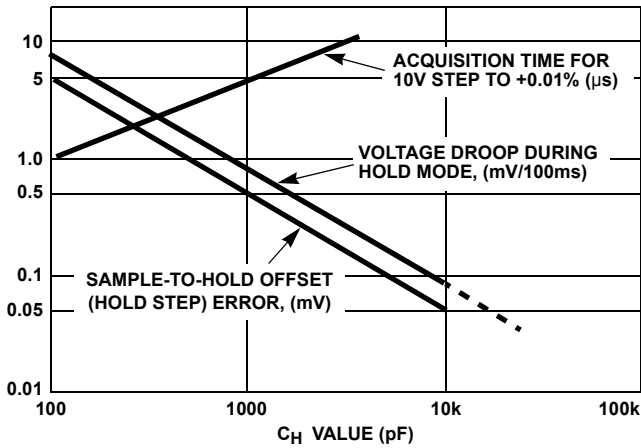

FIGURE 6. TYPICAL SAMPLE AND HOLD PERFORMANCE AS A FUNCTION OF HOLD CAPACITOR

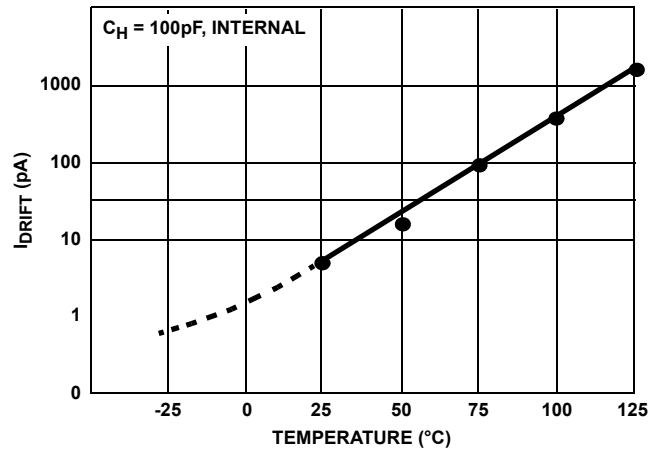

FIGURE 7. DRIFT CURRENT vs TEMPERATURE

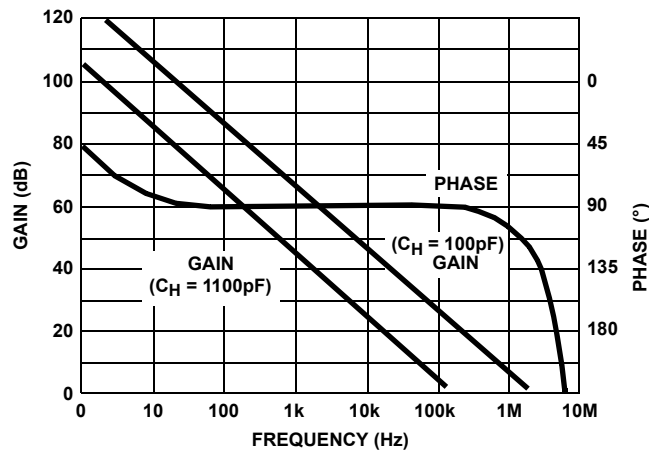

FIGURE 8. OPEN LOOP GAIN AND PHASE RESPONSE

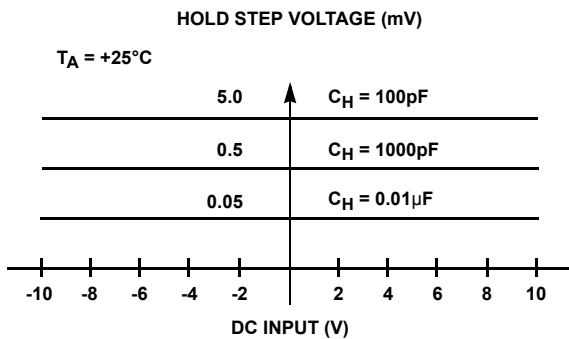

FIGURE 9A. HOLD STEP vs INPUT VOLTAGE

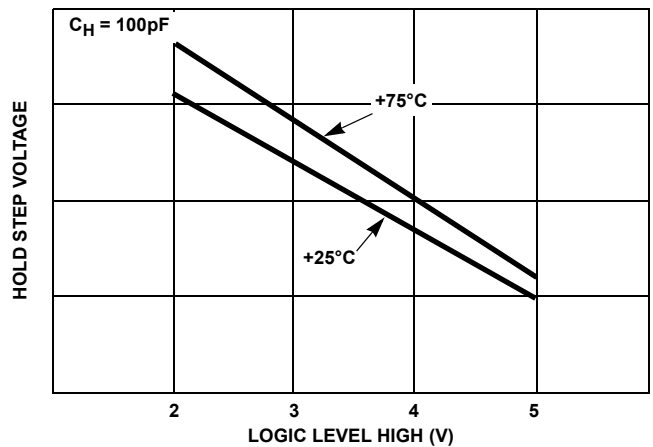

FIGURE 9B. HOLD STEP vs LOGIC ( $V_{IH}$ ) VOLTAGE

FIGURE 9. TYPICAL SAMPLE-TO-HOLD OFFSET (HOLD STEP) ERROR

## Die Characteristics

### DIE DIMENSIONS:

92 mils x 152 mils x 19 mils

### METALLIZATION:

Type: Al, 1% Cu  
 Thickness:  $16\text{k}\text{\AA} \pm 2\text{k}\text{\AA}$

### PASSIVATION:

Type: Nitride ( $\text{Si}_3\text{N}_4$ ) over Silox ( $\text{SiO}_2$ , 5% Phos)  
 Silox Thickness:  $12\text{k}\text{\AA} \pm 2\text{k}\text{\AA}$   
 Nitride Thickness:  $3.5\text{k}\text{\AA} \pm 1.5\text{k}\text{\AA}$

### TRANSISTOR COUNT:

184

### SUBSTRATE POTENTIAL:

V-

## Metallization Mask Layout

HA-5320

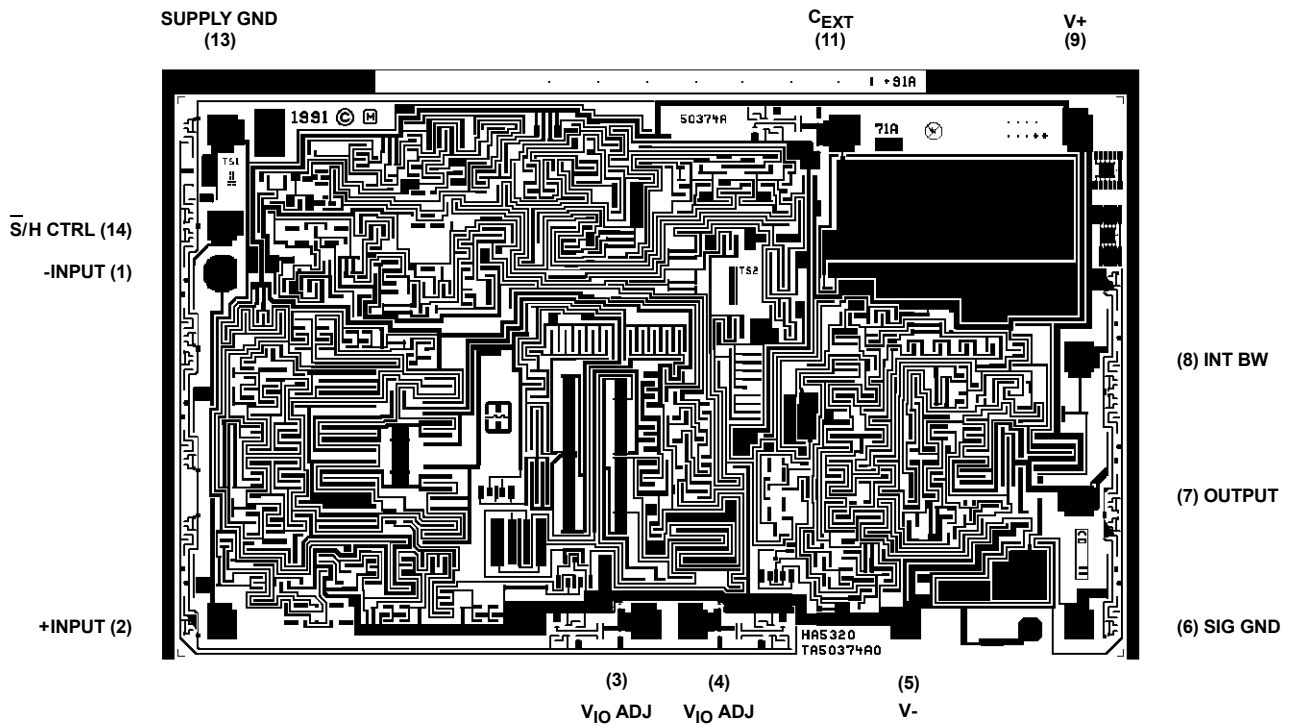

---

## Revision History

The revision history provided is for informational purposes only and is believed to be accurate, but not warranted. Please go to the web to make sure that you have the latest revision.

DATE	REVISION	CHANGE
August 11, 2015	FN2857.10	Added Rev History beginning with Rev 10. Added About Intersil Verbiage. Updated Ordering Information on page 1

---

## About Intersil

Intersil Corporation is a leading provider of innovative power management and precision analog solutions. The company's products address some of the largest markets within the industrial and infrastructure, mobile computing and high-end consumer markets.

For the most updated datasheet, application notes, related documentation and related parts, please see the respective product information page found at [www.intersil.com](http://www.intersil.com).

You may report errors or suggestions for improving this datasheet by visiting [www.intersil.com/ask](http://www.intersil.com/ask).

Reliability reports are also available from our website at [www.intersil.com/support](http://www.intersil.com/support)

**Ceramic Dual-In-Line Frit Seal Packages (CERDIP)**

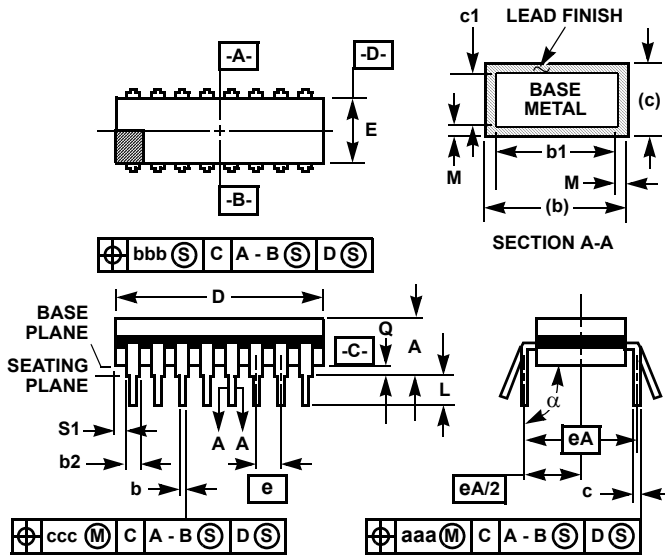

**NOTES:**

1. Index area: A notch or a pin one identification mark shall be located adjacent to pin one and shall be located within the shaded area shown. The manufacturer's identification shall not be used as a pin one identification mark.
2. The maximum limits of lead dimensions b and c or M shall be measured at the centroid of the finished lead surfaces, when solder dip or tin plate lead finish is applied.
3. Dimensions b1 and c1 apply to lead base metal only. Dimension M applies to lead plating and finish thickness.
4. Corner leads (1, N, N/2, and N/2+1) may be configured with a partial lead paddle. For this configuration dimension b3 replaces dimension b2.
5. This dimension allows for off-center lid, meniscus, and glass overrun.
6. Dimension Q shall be measured from the seating plane to the base plane.
7. Measure dimension S1 at all four corners.
8. N is the maximum number of terminal positions.
9. Dimensioning and tolerancing per ANSI Y14.5M - 1982.
10. Controlling dimension: INCH.

**F14.3 MIL-STD-1835 GDIP1-T14 (D-1, CONFIGURATION A)  
14 LEAD CERAMIC DUAL-IN-LINE FRIT SEAL PACKAGE**

SYMBOL	INCHES		MILLIMETERS		NOTES
	MIN	MAX	MIN	MAX	
A	-	0.200	-	5.08	-
b	0.014	0.026	0.36	0.66	2
b1	0.014	0.023	0.36	0.58	3
b2	0.045	0.065	1.14	1.65	-
b3	0.023	0.045	0.58	1.14	4
c	0.008	0.018	0.20	0.46	2
c1	0.008	0.015	0.20	0.38	3
D	-	0.785	-	19.94	5
E	0.220	0.310	5.59	7.87	5
e	0.100 BSC		2.54 BSC		-
eA	0.300 BSC		7.62 BSC		-
eA/2	0.150 BSC		3.81 BSC		-
L	0.125	0.200	3.18	5.08	-
Q	0.015	0.060	0.38	1.52	6
S1	0.005	-	0.13	-	7
$\alpha$	90°	105°	90°	105°	-
aaa	-	0.015	-	0.38	-
bbb	-	0.030	-	0.76	-
ccc	-	0.010	-	0.25	-
M	-	0.0015	-	0.038	2, 3
N	14		14		8

Rev. 0 4/94

**Small Outline Plastic Packages (SOIC)**

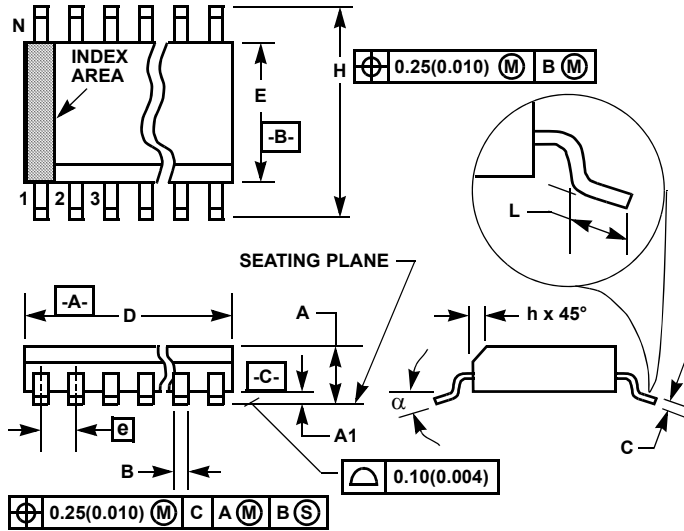

**M16.3 (JEDEC MS-013-AA ISSUE C)**  
**16 LEAD WIDE BODY SMALL OUTLINE PLASTIC PACKAGE**

SYMBOL	INCHES		MILLIMETERS		NOTES
	MIN	MAX	MIN	MAX	
A	0.0926	0.1043	2.35	2.65	-
A1	0.0040	0.0118	0.10	0.30	-
B	0.013	0.0200	0.33	0.51	9
C	0.0091	0.0125	0.23	0.32	-
D	0.3977	0.4133	10.10	10.50	3
E	0.2914	0.2992	7.40	7.60	4
e	0.050 BSC		1.27 BSC		-
H	0.394	0.419	10.00	10.65	-
h	0.010	0.029	0.25	0.75	5
L	0.016	0.050	0.40	1.27	6
N	16		16		7
$\alpha$	0°	8°	0°	8°	-

**NOTES:**

1. Symbols are defined in the "MO Series Symbol List" in Section 2.2 of Publication Number 95.
2. Dimensioning and tolerancing per ANSI Y14.5M-1982.
3. Dimension "D" does not include mold flash, protrusions or gate burrs. Mold flash, protrusion and gate burrs shall not exceed 0.15mm (0.006 inch) per side.
4. Dimension "E" does not include interlead flash or protrusions. Interlead flash and protrusions shall not exceed 0.25mm (0.010 inch) per side.
5. The chamfer on the body is optional. If it is not present, a visual index feature must be located within the crosshatched area.
6. "L" is the length of terminal for soldering to a substrate.
7. "N" is the number of terminal positions.
8. Terminal numbers are shown for reference only.
9. The lead width "B", as measured 0.36mm (0.014 inch) or greater above the seating plane, shall not exceed a maximum value of 0.61mm (0.024 inch)
10. Controlling dimension: MILLIMETER. Converted inch dimensions are not necessarily exact.

Rev. 1 6/05

© Copyright Intersil Americas LLC 2003-2015. All Rights Reserved.  
 All trademarks and registered trademarks are the property of their respective owners.

For additional products, see [www.intersil.com/en/products.html](http://www.intersil.com/en/products.html)

Intersil products are manufactured, assembled and tested utilizing ISO9001 quality systems as noted in the quality certifications found at [www.intersil.com/en/support/qualandreliability.html](http://www.intersil.com/en/support/qualandreliability.html)

*Intersil products are sold by description only. Intersil may modify the circuit design and/or specifications of products at any time without notice, provided that such modification does not, in Intersil's sole judgment, affect the form, fit or function of the product. Accordingly, the reader is cautioned to verify that datasheets are current before placing orders. Information furnished by Intersil is believed to be accurate and reliable. However, no responsibility is assumed by Intersil or its subsidiaries for its use; nor for any infringements of patents or other rights of third parties which may result from its use. No license is granted by implication or otherwise under any patent or patent rights of Intersil or its subsidiaries.*

For information regarding Intersil Corporation and its products, see [www.intersil.com](http://www.intersil.com)

## Looking for pricing, stock, or lifecycle information?

Click below to explore more details on WIN SOURCE:

 [View HA3-5320-5 on WIN SOURCE](#)

 [Intersil Information](#)

## Optimize Your Supply Chain with WIN SOURCE Solutions

-  Global Sourcing Solution
-  Obsolete Management
-  Cost Control Management
-  Shortage Management
-  Alternative Solution
-  Excess Inventory Management