



# THE DATASHEET OF H2001DG





## Product Specification for Approval

WE ARE PLEASED IN SUBMITTING OUR SAMPLES WITH SPECIFICATION TO YOU FOR APPROVAL.

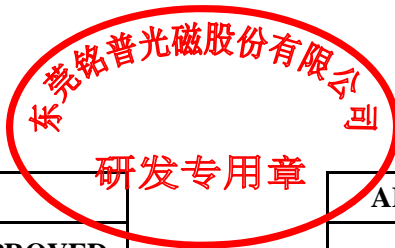
CUSTOMER	:		
DESCRIPTION	:	10/100 BASE-T TRANSFORMER	
MNC P/N	:	H2001DG	
VERSION	:	A0	
CUSTOMER P/N	:		
ISSUED DATE	:	2020/04/27	
PHOTO OF PRODUCT	:		
WEIGHT	:		1.88g
MADE IN	:		CHINA



APPROVED BY MNC			APPROVED BY CUSTOMER
<b>PREPARED BY</b>  研发部 2020-04-27 符晶晶	<b>CHECKED BY</b>  研发部 2020-04-27 肖明华	<b>APPROVED BY</b>  研发部 2020-04-27 何校民	<b>SIGNATURE OR STAMP</b>  

1. PLEASE SEND BACK US A COPY OF THE SPECIFICATION WITH YOUR STAMP OR SIGNATURE ONCE THE SAMPLES APPROVED.
2. IT WILL BE DEEMED THE SAMPLES TO BE APPROVED IF NO FEEDBACK.

东莞铭普光磁股份有限公司  
 Add: Shipai Town, Dongguan City, Guangdong Province, China

TEL: +86-769-86921000  
 FAX: +86-769-81701563

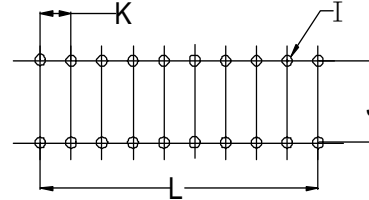
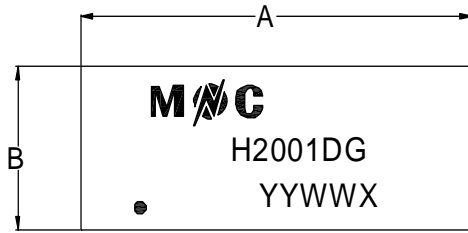

**A. MECHANICAL :**

SUGGESTED PAD LAYOUT

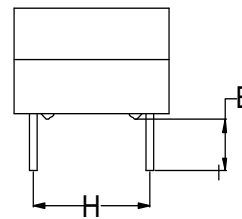
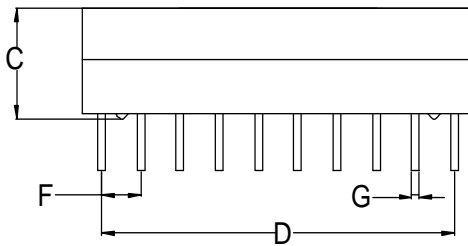

Note: White ink marking

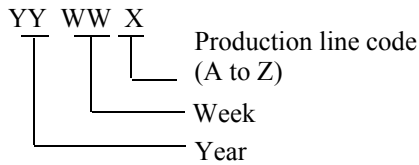

1. UNITS: mm/inch.
2. UNLESS OTHERWISE SPECIFIED ALL TOLERANCES ARE: TYPICAL
3. PIN LENGTH DON'T INCLUDE SOLDER POINT

DIM	MILLIMETERS			INCHES		
	MIN	NOM	MAX	MIN	NOM	MAX
A	24.70	25.20	25.70	0.972	0.992	1.012
B	9.50	10.00	10.50	0.374	0.394	0.413
C	/	/	6.75	/	/	0.266
D	/	22.86	/	/	0.900	/
E	2.90	3.20	3.50	0.114	0.126	0.138
F	/	2.54	/	/	0.100	/
G	/	0.50	/	/	0.020	/
H	/	7.62	/	/	0.300	/
I	/	0.80	/	/	0.031	/
J	/	7.62	/	/	0.300	/
K	/	2.54	/	/	0.100	/
L	/	22.86	/	/	0.900	/

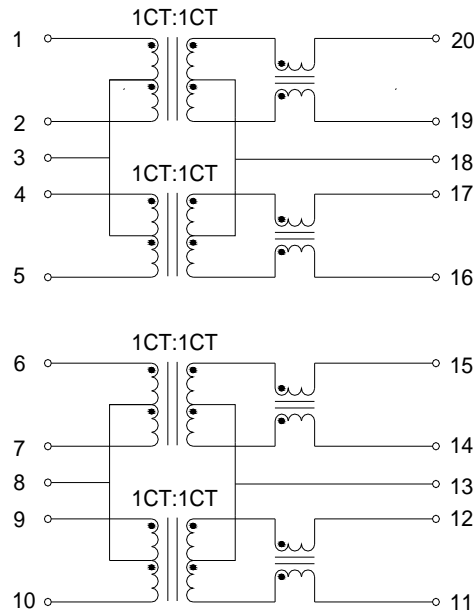
**B. SCHEMATIC :**

**C. ELECTRICAL SPECIFICATION @25°C**

ITEM	SPECIFICATION	TEST CONDITION	TEST EQUIPMENT
INDUCTANCE :	350uH MIN.	100KHz 0.2V 8mA DC Bias	TH2819XB OR EQU.
LEAKAGE INDUCTANCE :	0.50uH MAX.	100KHz 0.2V	TH2819XB OR EQU.
INTERWINDING CAPACITANCE :	50pF TYP.	100KHz 0.2V	TH2819XB OR EQU.
DC RESISTANCE :	1.2Ω MAX.	AT 25 °C	TOS 8020 OR EQU.
TURNS RATIO :	1CT:1CT±5%		TH2819XB OR EQU.
POLARITY :	1-20,4-17,6-15, 9-12IN-PHASE		
INSERTION LOSS :	-1.1dB MAX.	0.5-100 MHz	E5061A OR EQU.
RETURN LOSS :	-18dB MIN.	0.5-30 MHz	E5061A OR EQU.
	-18+20log(f/30)dB MIN.	30.1-60MHz	
	-12dB MIN.	60.1-80MHz	
CROSS TALK :	-35dB MIN.	0.5-40 MHz	E5061A OR EQU.
	-33+20*log(f/50)dB MIN.	40.1-100 MHz	
CMRR :	-30dB MIN.	0.5-100 MHz	E5061A OR EQU.
ISOLATION HI-POT :PRI TO SEC	1500VAC	1mA,60S	7152AB OR EQU.
	1650VAC	1mA,6S	
OPERATING TEMPERATURE	0°C TO 70°C		

**PACKAGE**

**Part No. H2001DG**

**D. PACKING:**

**a. PACKAGING AS BELOW (ONLY FOR A REFERENCE):**

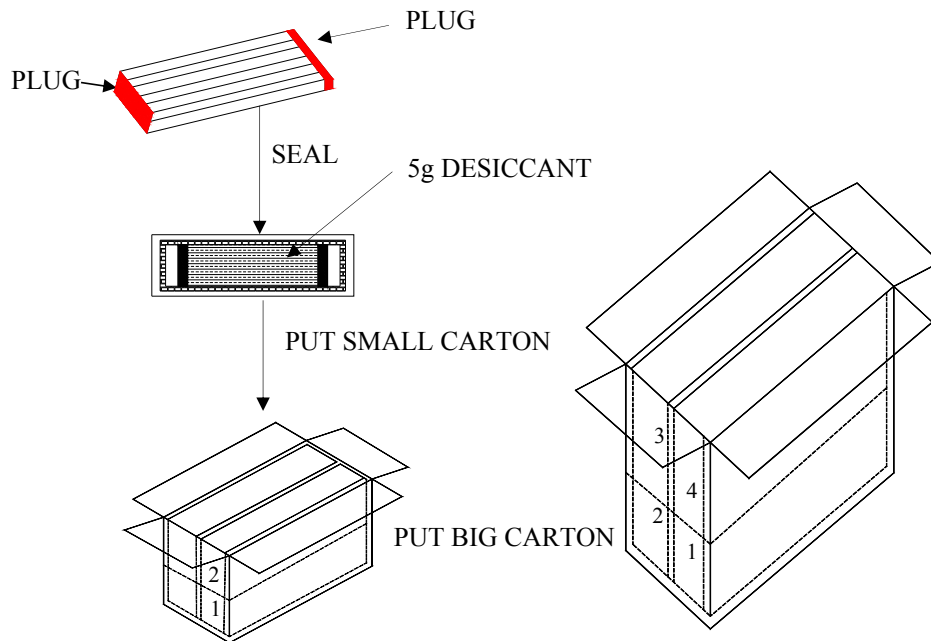
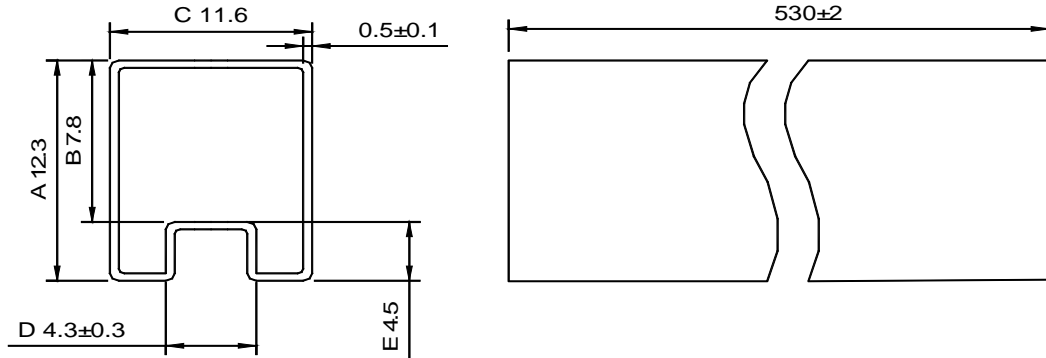

**b. Q'TY:**

- 20 PCS PER TUBE
- 5 TUBES PER BUNDLE (100 PCS)
- 10 BUNDLES (1000 PCS)
- 1 BAG PER SMALL CARTON
- 4 SMALL CARTON PER BIG CARTON(4000PCS)

**c. LABEL:**



**REMARK:**

ABOVE PACKING IS FOR YOUR REFERENCE ONLY, WHICH MIGHT BE CHANGED WITHOUT NOTICE.

**E.BOM**

<b>MATERIAL LIST</b>					
<b>NO.</b>	<b>ITEM</b>	<b>MATERIAL</b>	<b>RATING</b>	<b>SUPPLIER OF MATERIAL</b>	<b>UL</b>
<b>1</b>	<b>CORE</b>	<b>Mn-Zn</b>	-----	<b>YEAN SHING</b>	<b>N/A</b>
			-----	<b>ZHONGSHAN CRC ELECTRONICS FACTORY</b>	<b>N/A</b>
		<b>Ni-Zn</b>	-----	<b>YEAN SHING</b>	<b>N/A</b>
			-----	<b>ZHONGSHAN CRC ELECTRONICS FACTORY</b>	<b>N/A</b>
<b>2</b>	<b>COPPER WIRE</b>	<b>QPN180</b>	<b>180 °C</b>	<b>ZHUHAI SUNTEK WIRE CO.,LTD</b>	<b>E234867</b>
		<b>Polysol 180</b>	<b>180 °C</b>	<b>ELEKTRISOLA(MALAYSIA) SDN.BHD.</b>	<b>E258243</b>
<b>3</b>	<b>CASE</b>	<b>PF2A5-151J(b)</b>	<b>V-0</b>	<b>CHANGSHU SOUTH-EAST PLASTIC CO.,LTD</b>	<b>E136137</b>
		<b>T378J</b>	<b>150 °C</b>	<b>CHANG CHUN PLASTICS CO.,LTD</b>	<b>E59481</b>
<b>4</b>	<b>PIN</b>	<b>CP WIRE</b>	-----	<b>HIFAM</b>	<b>N/A</b>
<b>5</b>	<b>EPOXY</b>	<b>3300A/B</b>	-----	<b>DONGGUAN EATTO ELECTRONIC MATERIAL CO.,LTD</b>	<b>E218090</b>

**RECOMMENDED SOLDERING PROFILE****Part No. H2001DG****a. RECOMMENDED WAVE SOLDERING PROFILE:****CONDITION:**

- a.1. AVAILABLE FOR ALL THE THROUGH HOLE PARTS
- a.2. SOLDERING METHOD: WAVE SOLDERING
- a.3. SOLDER: Sn-0.7Cu
- a.4. THE RECOMMENDED WAVE SOLDERING CURVE IS AS BELOW

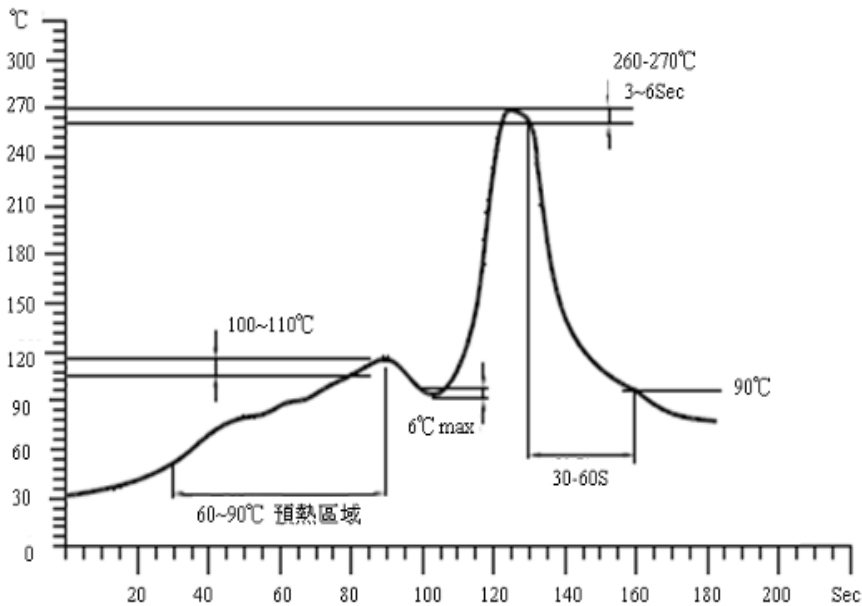
**b. MOISTURE SENSITIVE LEVEL:**

- b.1. LEVEL: 1
- b.2. SHELF LIFE: UNLIMITED
- b.3. STORAGE CONDITION:  $\leq 30^{\circ}\text{C}/85\% \text{RH}$

## Looking for pricing, stock, or lifecycle information?

Click below to explore more details on WIN SOURCE:

- [View H2001DG on WIN SOURCE](#)
- [Mentech Technology USA Inc. Information](#)

## Optimize Your Supply Chain with WIN SOURCE Solutions

- ✓ Global Sourcing Solution
- ✓ Obsolete Management
- ✓ Cost Control Management
- ✓ Shortage Management
- ✓ Alternative Solution
- ✓ Excess Inventory Management