

GTL2012

2-bit LVTTTL to GTL transceiver

Rev. 01 — 9 August 2007

Product data sheet

1. General description

The GTL2012 is a 2-bit translating transceiver designed for 3.3 V system interface with a GTL-/GTL/GTL+ bus.

The direction pin (DIR) allows the part to function as either a GTL-to-LVTTTL sampling receiver or as an LVTTTL-to-GTL interface.

The GTL2012 LVTTTL inputs (only) are tolerant up to 5.5 V allowing direct access to TTL or 5 V CMOS inputs.

2. Features

- Operates as a 2-bit GTL-/GTL/GTL+ sampling receiver or as an LVTTTL to GTL-/GTL/GTL+ driver
- 3.0 V to 3.6 V operation with 5 V tolerant LVTTTL input
- GTL input and output 3.6 V tolerant
- V_{ref} adjustable from 0.5 V to $0.5V_{CC}$
- Partial power-down permitted
- Latch-up protection exceeds 500 mA per JESD78
- ESD protection exceeds 2000 V HBM per JESD22-A114, 200 V MM per JESD22-A115, and 1000 V CDM per JESD22-CC101
- Package offered: TSSOP8 (MSOP8) and VSSOP8

3. Quick reference data

Table 1. Quick reference data

Recommended operating conditions; $T_{amb} = 25\text{ }^{\circ}\text{C}$

Symbol	Parameter	Conditions	Min	Typ ^[1]	Max	Unit
C_i	input capacitance	control inputs; $V_I = 3.0\text{ V}$ or 0 V	-	2	2.5	pF
C_{io}	input/output capacitance	A port; $V_O = 3.0\text{ V}$ or 0 V	-	4.6	6	pF
		B port; $V_O = V_{TT}$ or 0 V	-	3.4	4.3	pF
GTL; $V_{ref} = 0.8\text{ V}$; $V_{TT} = 1.2\text{ V}$						
t_{PLH}	LOW-to-HIGH propagation delay	An to Bn; see Figure 4	-	2.8	5	ns
t_{PHL}	HIGH-to-LOW propagation delay	An to Bn; see Figure 4	-	3.4	7	ns
t_{PLH}	LOW-to-HIGH propagation delay	Bn to An; see Figure 5	-	5.2	8	ns
t_{PHL}	HIGH-to-LOW propagation delay	Bn to An; see Figure 5	-	4.9	7	ns

[1] All typical values are measured at $V_{CC} = 3.3\text{ V}$ and $T_{amb} = 25\text{ }^{\circ}\text{C}$.

4. Ordering information

Table 2. Ordering information

$T_{amb} = -40\text{ }^{\circ}\text{C to } +85\text{ }^{\circ}\text{C}$

Type number	Topside mark	Package		
		Name	Description	Version
GTL2012DP	012P	TSSOP8 ^[1]	plastic thin shrink small outline package; 8 leads; body width 3 mm	SOT505-1
GTL2012DC	012C	VSSOP8	plastic very thin shrink small outline package; 8 leads; body width 2.3 mm	SOT765-1

[1] Also known as MSOP8.

5. Functional diagram

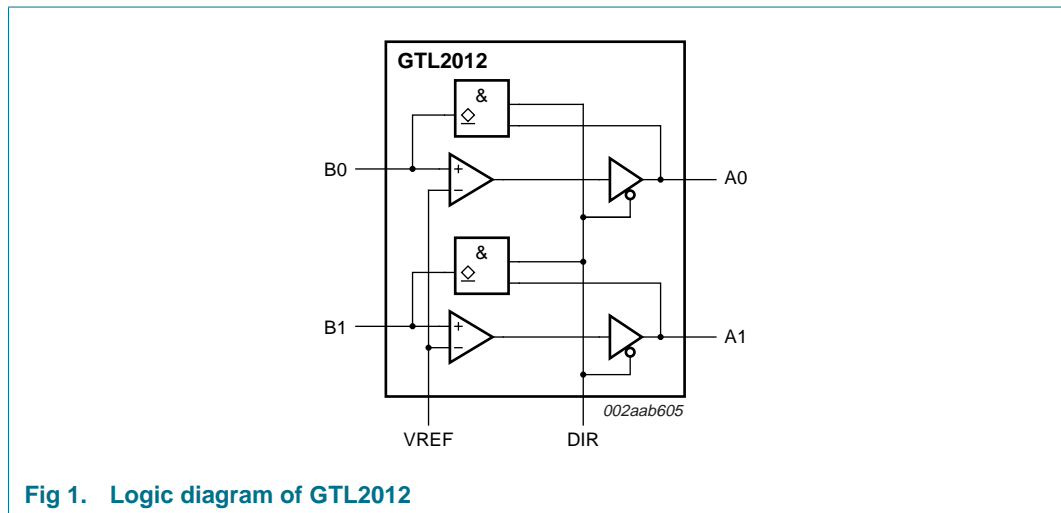
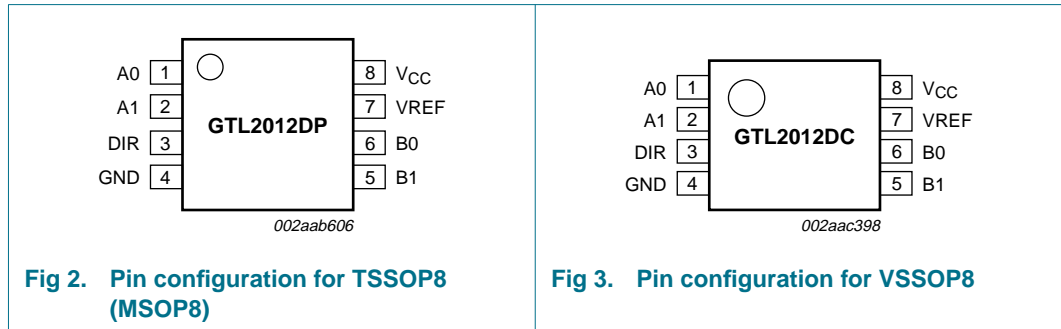

Fig 1. Logic diagram of GTL2012

6. Pinning information

6.1 Pinning



6.2 Pin description

Table 3. Pin description

Symbol	Pin	Description
A0	1	data inputs/outputs (A side, LVTTTL)
A1	2	
DIR	3	direction control input (LVTTTL)
GND	4	ground (0 V)
B1	5	data inputs/outputs (B side, GTL)
B0	6	
VREF	7	GTL reference voltage
V _{CC}	8	positive supply voltage

7. Functional description

Refer to [Figure 1 “Logic diagram of GTL2012”](#).

7.1 Function table

Table 4. Function table

H = HIGH voltage level; L = LOW voltage level.

Input	Input/output	
DIR	A (LVTTTL)	B (GTL)
H	inputs	B _n = A _n
L	A _n = B _n	inputs

8. Limiting values

Table 5. Limiting values

In accordance with the Absolute Maximum Rating System (IEC 60134). Voltages are referenced to GND (ground = 0 V).

Symbol	Parameter	Conditions	Min	Max	Unit
V_{CC}	supply voltage		-0.5	+4.6	V
I_{IK}	input clamping current	$V_I < 0$ V	-	-50	mA
V_I	input voltage	A port	[1] -0.5	+7.0	V
		B port	[1] -0.5	+4.6	V
I_{OK}	output clamping current	$V_O < 0$ V	-	-50	mA
V_O	output voltage	output in OFF or HIGH state; A port	[1] -0.5	+7.0	V
		output in OFF or HIGH state; B port	[1] -0.5	+4.6	V
I_{OL}	LOW-level output current[2]	A port	-	32	mA
		B port	-	80	mA
I_{OH}	HIGH-level output current[3]	A port	-	-32	mA
T_{stg}	storage temperature		[4] -60	+150	°C

- [1] The input and output negative voltage ratings may be exceeded if the input and output clamping current ratings are observed.
 [2] Current into any output in the LOW state.
 [3] Current into any output in the HIGH state.
 [4] The performance capability of a high-performance integrated circuit in conjunction with its thermal environment can create junction temperatures which are detrimental to reliability. The maximum junction temperature of this integrated circuit should not exceed 150 °C.

9. Recommended operating conditions

Table 6. Recommended operating conditions[1]

Unused inputs must be held HIGH or LOW to prevent them from floating.

Symbol	Parameter	Conditions	Min	Typ	Max	Unit
V_{CC}	supply voltage		3.0	-	3.6	V
V_{TT}	termination voltage[2]	GTL-	0.85	0.9	0.95	V
		GTL	1.14	1.2	1.26	V
		GTL+	1.35	1.5	1.65	V
V_{ref}	reference voltage	overall	0.5	$\frac{2}{3}V_{TT}$	$0.5V_{CC}$	V
		GTL-	0.5	0.6	0.63	V
		GTL	0.76	0.8	0.84	V
		GTL+	0.87	1.0	1.10	V
V_I	input voltage	B port	0	V_{TT}	3.6	V
		except B port	[3] 0	3.3	5.5	V
V_{IH}	HIGH-level input voltage	B port	$V_{ref} + 0.050$	-	-	V
		except B port	2	-	-	V
V_{IL}	LOW-level input voltage	B port	-	-	$V_{ref} - 0.050$	V
		except B port	-	-	0.8	V
I_{OH}	HIGH-level output current	A port	-	-	-16	mA

Table 6. Recommended operating conditions^[1] ...continued
 Unused inputs must be held HIGH or LOW to prevent them from floating.

Symbol	Parameter	Conditions	Min	Typ	Max	Unit
I _{OL}	LOW-level output current	B port	-	-	40	mA
		A port	-	-	16	mA
T _{amb}	ambient temperature	operating in free-air	-40	-	+85	°C

- [1] Unused inputs must be held HIGH or LOW to prevent them from floating.
- [2] V_{TT} maximum of 3.6 V with resistor sized so I_{OL} maximum is not exceeded.
- [3] A0, A1 V_{I(max)} is 3.6 V if configured as outputs (DIR = L).

10. Static characteristics

Table 7. Static characteristics
 Recommended operating conditions; voltages are referenced to GND (ground = 0 V); T_{amb} = -40 °C to +85 °C.

Symbol	Parameter	Conditions	Min	Typ ^[1]	Max	Unit
V _{OH}	HIGH-level output voltage	A port; V _{CC} = 3.0 V to 3.6 V; I _{OH} = -100 μA	[2] V _{CC} - 0.2	-	-	V
		A port; V _{CC} = 3.0 V; I _{OH} = -16 mA	[2] 2.0	-	-	V
V _{OL}	LOW-level output voltage	B port; V _{CC} = 3.0 V; I _{OL} = 40 mA	[2] -	0.23	0.4	V
		A port; V _{CC} = 3.0 V; I _{OL} = 8 mA	[2] -	0.28	0.4	V
		A port; V _{CC} = 3.0 V; I _{OL} = 12 mA	[2] -	0.40	0.55	V
		A port; V _{CC} = 3.0 V; I _{OL} = 16 mA	[2] -	0.55	0.8	V
I _I	input current	control inputs; V _{CC} = 3.6 V; V _I = V _{CC} or GND	-	-	±1	μA
		B port; V _{CC} = 3.6 V; V _I = V _{TT} or GND	-	-	±1	μA
		A port; V _{CC} = 0 V or 3.6 V; V _I = 5.5 V	-	-	10	μA
		A port; V _{CC} = 3.6 V; V _I = V _{CC}	-	-	±1	μA
		A port; V _{CC} = 3.6 V; V _I = 0 V	-	-	-5	μA
I _{OZ}	off-state output current	A port; V _{CC} = 0 V; V _I or V _O = 0 V to 3.6 V	-	-	±100	μA
I _{CC}	supply current	A port; V _{CC} = 3.6 V; V _I = V _{CC} or GND; I _O = 0 mA	-	4	10	mA
		B port; V _{CC} = 3.6 V; V _I = V _{TT} or GND; I _O = 0 mA	-	4	10	mA
ΔI _{CC} ^[3]	additional supply current	per input; A port or control inputs; V _{CC} = 3.6 V; V _I = V _{CC} - 0.6 V	-	-	500	μA
C _i	input capacitance	control inputs; V _I = 3.0 V or 0 V	-	2	2.5	pF
C _{io}	input/output capacitance	A port; V _O = 3.0 V or 0 V	-	4.6	6	pF
		B port; V _O = V _{TT} or 0 V	-	3.4	4.3	pF

- [1] All typical values are measured at V_{CC} = 3.3 V and T_{amb} = 25 °C.
- [2] The input and output voltage ratings may be exceeded if the input and output current ratings are observed.
- [3] This is the increase in supply current for each input that is at the specified TTL voltage level rather than V_{CC} or GND.

11. Dynamic characteristics

Table 8. Dynamic characteristics

$V_{CC} = 3.3\text{ V} \pm 0.3\text{ V}$

Symbol	Parameter	Conditions	Min	Typ ^[1]	Max	Unit
GTL-; $V_{ref} = 0.6\text{ V}$; $V_{TT} = 0.9\text{ V}$						
t_{PLH}	LOW-to-HIGH propagation delay	An to Bn; see Figure 4	-	2.8	5	ns
t_{PHL}	HIGH-to-LOW propagation delay	An to Bn; see Figure 4	-	3.3	7	ns
t_{PLH}	LOW-to-HIGH propagation delay	Bn to An; see Figure 5	-	5.3	8	ns
t_{PHL}	HIGH-to-LOW propagation delay	Bn to An; see Figure 5	-	5.2	8	ns
GTL; $V_{ref} = 0.8\text{ V}$; $V_{TT} = 1.2\text{ V}$						
t_{PLH}	LOW-to-HIGH propagation delay	An to Bn; see Figure 4	-	2.8	5	ns
t_{PHL}	HIGH-to-LOW propagation delay	An to Bn; see Figure 4	-	3.4	7	ns
t_{PLH}	LOW-to-HIGH propagation delay	Bn to An; see Figure 5	-	5.2	8	ns
t_{PHL}	HIGH-to-LOW propagation delay	Bn to An; see Figure 5	-	4.9	7	ns
GTL+; $V_{ref} = 1.0\text{ V}$; $V_{TT} = 1.5\text{ V}$						
t_{PLH}	LOW-to-HIGH propagation delay	An to Bn; see Figure 4	-	2.8	5	ns
t_{PHL}	HIGH-to-LOW propagation delay	An to Bn; see Figure 4	-	3.4	7	ns
t_{PLH}	LOW-to-HIGH propagation delay	Bn to An; see Figure 5	-	5.1	8	ns
t_{PHL}	HIGH-to-LOW propagation delay	Bn to An; see Figure 5	-	4.7	7	ns

[1] All typical values are at $V_{CC} = 3.3\text{ V}$ and $T_{amb} = 25\text{ }^\circ\text{C}$.

11.1 Waveforms

$V_M = 1.5\text{ V}$ at $V_{CC} \geq 3.0\text{ V}$; $V_M = 0.5V_{CC}$ at $V_{CC} \leq 2.7\text{ V}$ for A ports and control pins;
 $V_M = V_{ref}$ for B ports.

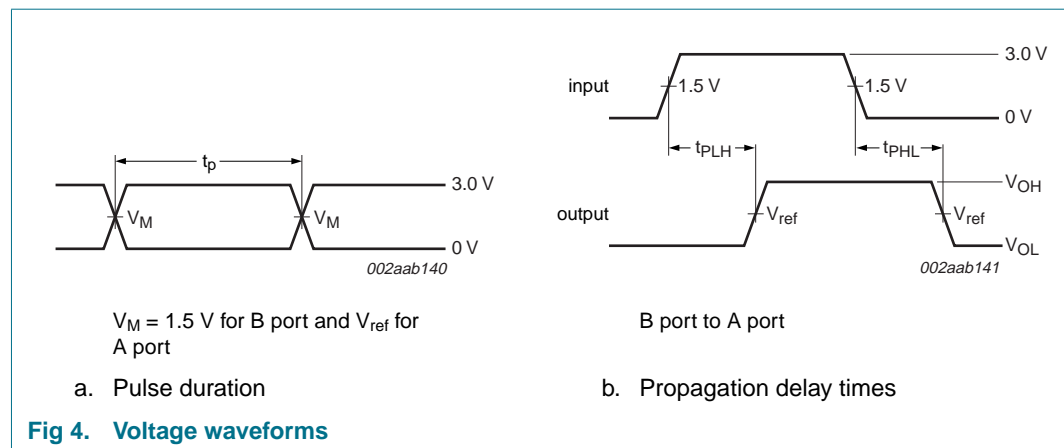

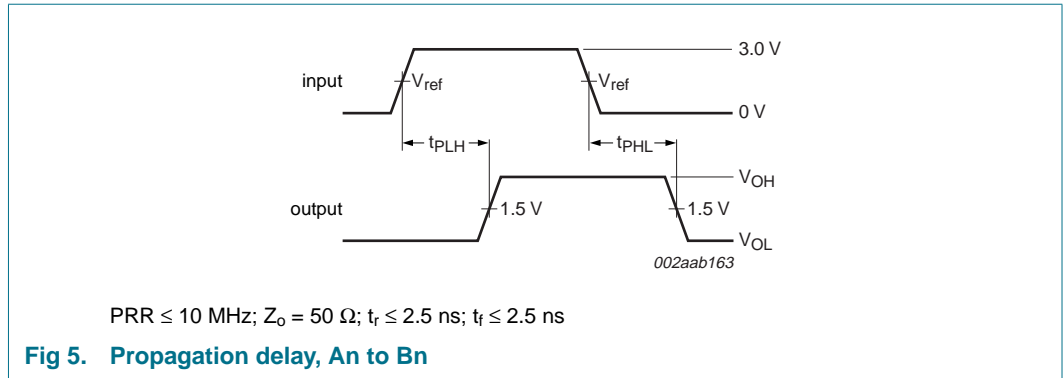

12. Test information

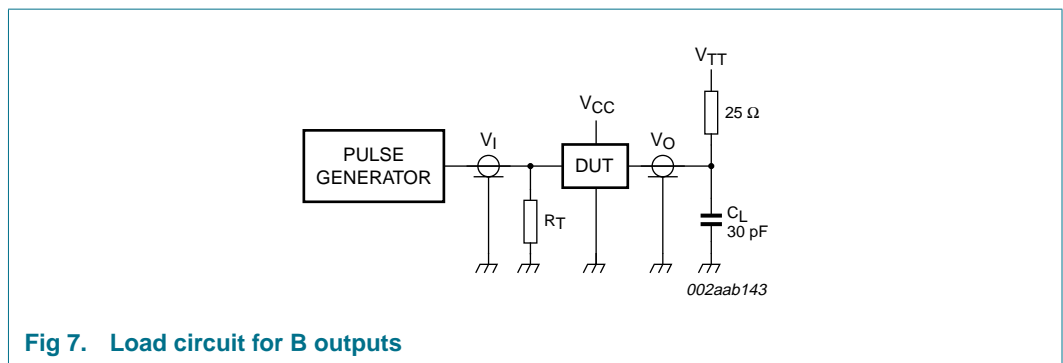
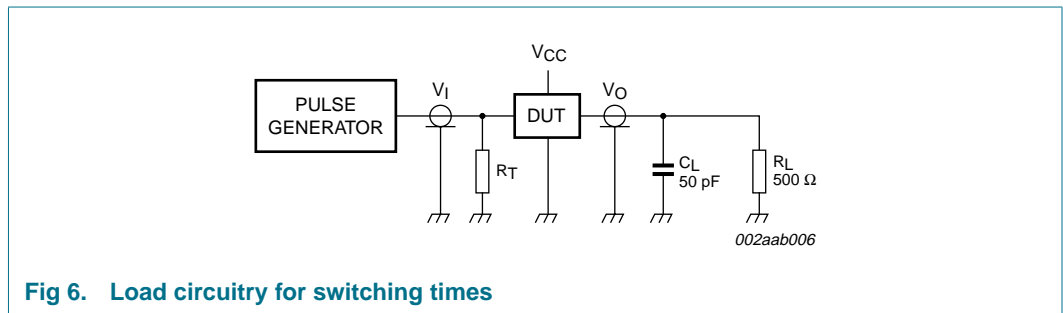

- R_L — Load resistor.
- C_L — Load capacitance; includes jig and probe capacitance.
- R_T — Termination resistance; should be equal to Z_o of pulse generators.

13. Package outline

TSSOP8: plastic thin shrink small outline package; 8 leads; body width 3 mm

SOT505-1

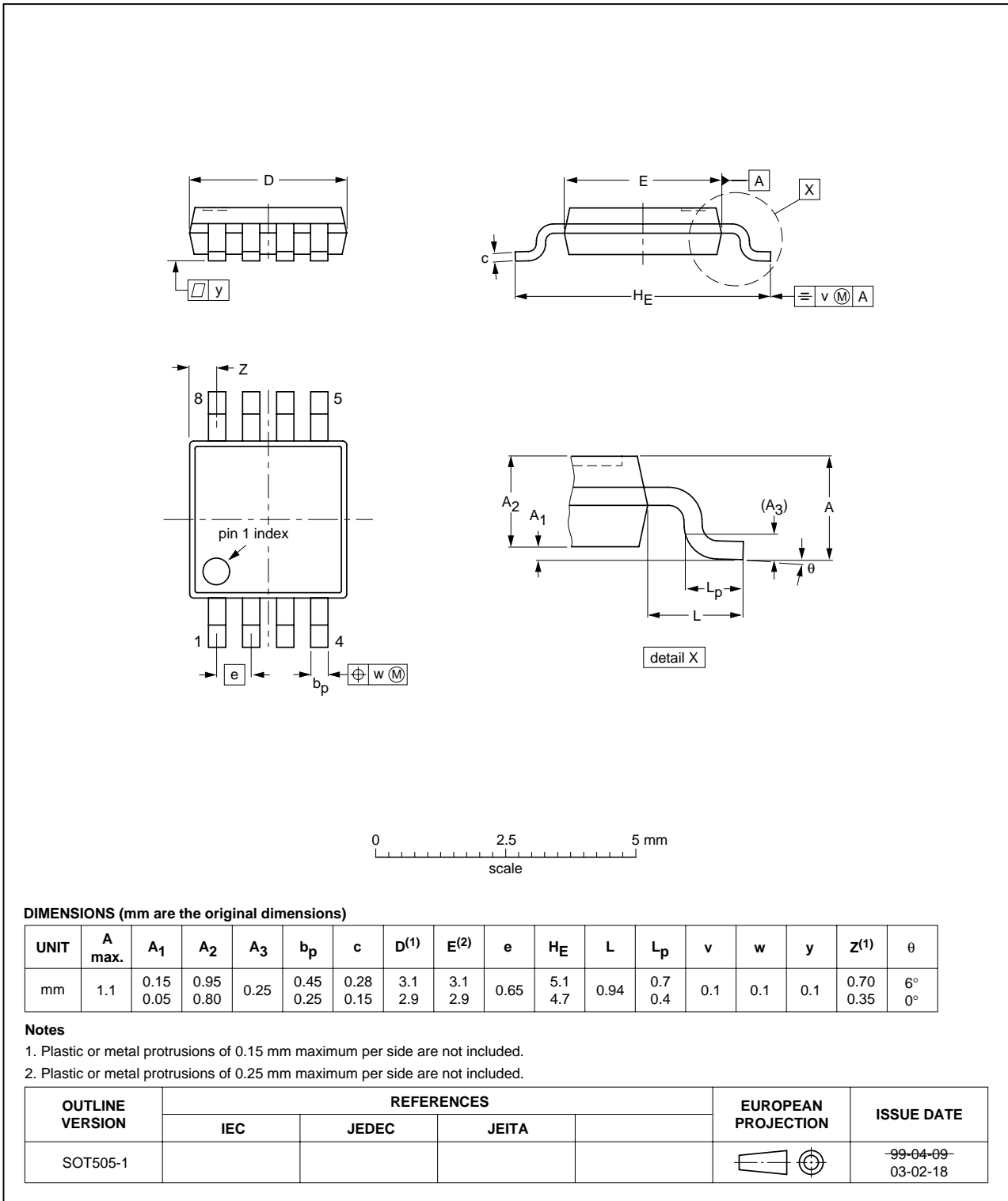

Fig 8. Package outline SOT505-1 (TSSOP8)

VSSOP8: plastic very thin shrink small outline package; 8 leads; body width 2.3 mm

SOT765-1

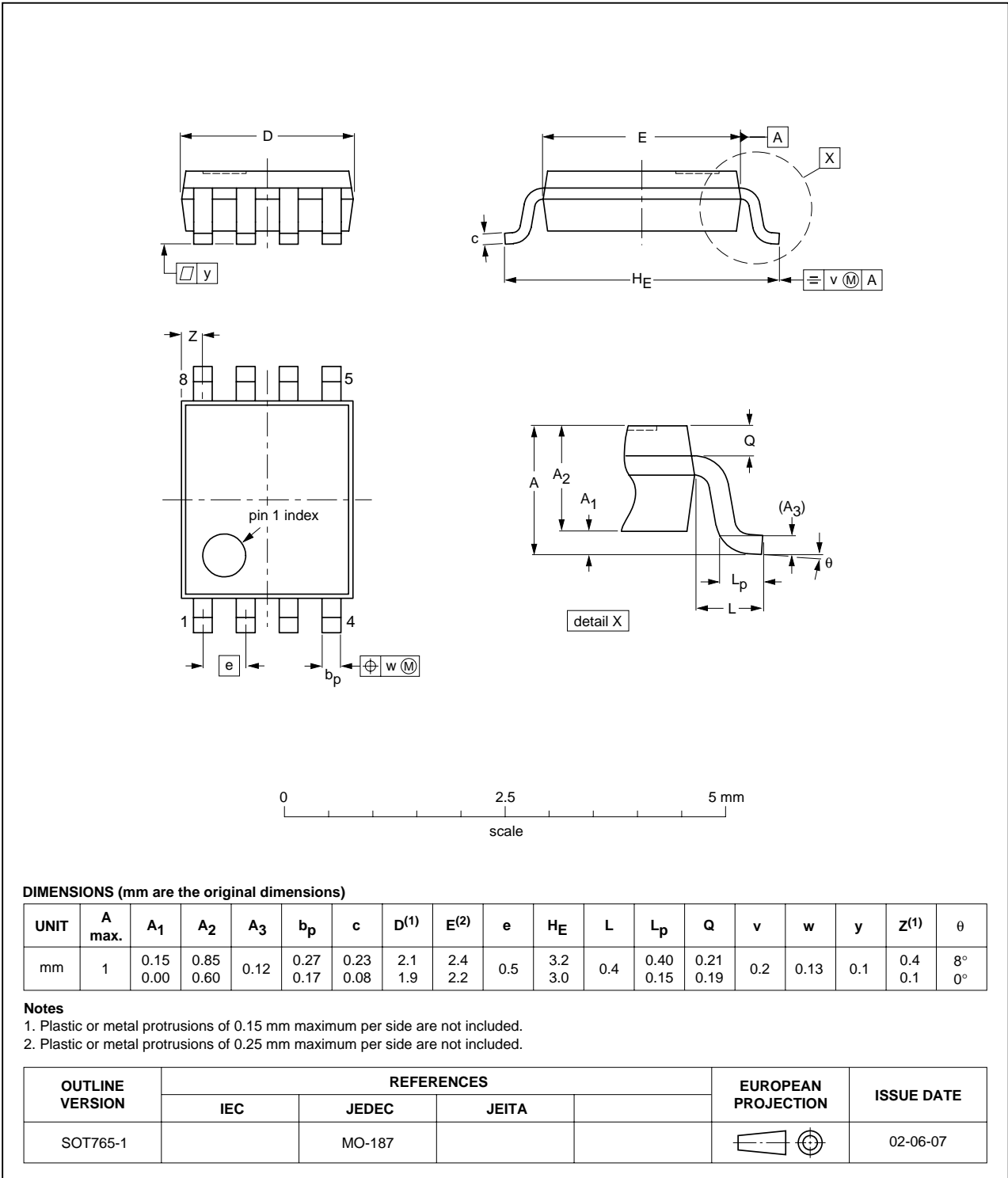

Fig 9. Package outline SOT765-1 (VSSOP8)

14. Soldering

This text provides a very brief insight into a complex technology. A more in-depth account of soldering ICs can be found in Application Note *AN10365 "Surface mount reflow soldering description"*.

14.1 Introduction to soldering

Soldering is one of the most common methods through which packages are attached to Printed Circuit Boards (PCBs), to form electrical circuits. The soldered joint provides both the mechanical and the electrical connection. There is no single soldering method that is ideal for all IC packages. Wave soldering is often preferred when through-hole and Surface Mount Devices (SMDs) are mixed on one printed wiring board; however, it is not suitable for fine pitch SMDs. Reflow soldering is ideal for the small pitches and high densities that come with increased miniaturization.

14.2 Wave and reflow soldering

Wave soldering is a joining technology in which the joints are made by solder coming from a standing wave of liquid solder. The wave soldering process is suitable for the following:

- Through-hole components
- Leaded or leadless SMDs, which are glued to the surface of the printed circuit board

Not all SMDs can be wave soldered. Packages with solder balls, and some leadless packages which have solder lands underneath the body, cannot be wave soldered. Also, leaded SMDs with leads having a pitch smaller than ~0.6 mm cannot be wave soldered, due to an increased probability of bridging.

The reflow soldering process involves applying solder paste to a board, followed by component placement and exposure to a temperature profile. Leaded packages, packages with solder balls, and leadless packages are all reflow solderable.

Key characteristics in both wave and reflow soldering are:

- Board specifications, including the board finish, solder masks and vias
- Package footprints, including solder thieves and orientation
- The moisture sensitivity level of the packages
- Package placement
- Inspection and repair
- Lead-free soldering versus PbSn soldering

14.3 Wave soldering

Key characteristics in wave soldering are:

- Process issues, such as application of adhesive and flux, clinching of leads, board transport, the solder wave parameters, and the time during which components are exposed to the wave
- Solder bath specifications, including temperature and impurities

14.4 Reflow soldering

Key characteristics in reflow soldering are:

- Lead-free versus SnPb soldering; note that a lead-free reflow process usually leads to higher minimum peak temperatures (see [Figure 10](#)) than a PbSn process, thus reducing the process window
- Solder paste printing issues including smearing, release, and adjusting the process window for a mix of large and small components on one board
- Reflow temperature profile; this profile includes preheat, reflow (in which the board is heated to the peak temperature) and cooling down. It is imperative that the peak temperature is high enough for the solder to make reliable solder joints (a solder paste characteristic). In addition, the peak temperature must be low enough that the packages and/or boards are not damaged. The peak temperature of the package depends on package thickness and volume and is classified in accordance with [Table 9](#) and [10](#)

Table 9. SnPb eutectic process (from J-STD-020C)

Package thickness (mm)	Package reflow temperature (°C)	
	Volume (mm ³)	
	< 350	≥ 350
< 2.5	235	220
≥ 2.5	220	220

Table 10. Lead-free process (from J-STD-020C)

Package thickness (mm)	Package reflow temperature (°C)		
	Volume (mm ³)		
	< 350	350 to 2000	> 2000
< 1.6	260	260	260
1.6 to 2.5	260	250	245
> 2.5	250	245	245

Moisture sensitivity precautions, as indicated on the packing, must be respected at all times.

Studies have shown that small packages reach higher temperatures during reflow soldering, see [Figure 10](#).

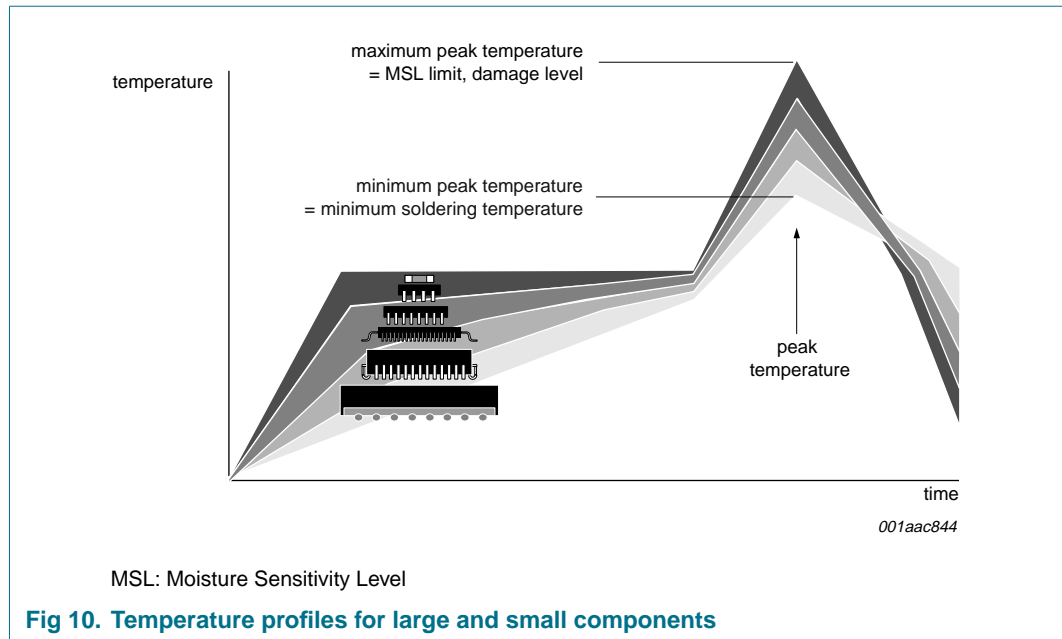

For further information on temperature profiles, refer to Application Note AN10365 “Surface mount reflow soldering description”.

15. Abbreviations

Table 11. Abbreviations

Acronym	Description
CDM	Charged Device Model
CMOS	Complementary Metal Oxide Silicon
DUT	Device Under Test
ESD	ElectroStatic Discharge
GTL	Gunning Transceiver Logic
HBM	Human Body Model
LVTTTL	Low Voltage Transistor-Transistor Logic
MM	Machine Model
PRR	Pulse Repetition Rate
TTL	Transistor-Transistor Logic

16. Revision history

Table 12. Revision history

Document ID	Release date	Data sheet status	Change notice	Supersedes
GTL2012_1	20070809	Product data sheet	-	-

17. Legal information

17.1 Data sheet status

Document status ^{[1][2]}	Product status ^[3]	Definition
Objective [short] data sheet	Development	This document contains data from the objective specification for product development.
Preliminary [short] data sheet	Qualification	This document contains data from the preliminary specification.
Product [short] data sheet	Production	This document contains the product specification.

[1] Please consult the most recently issued document before initiating or completing a design.

[2] The term 'short data sheet' is explained in section "Definitions".

[3] The product status of device(s) described in this document may have changed since this document was published and may differ in case of multiple devices. The latest product status information is available on the Internet at URL <http://www.nxp.com>.

17.2 Definitions

Draft — The document is a draft version only. The content is still under internal review and subject to formal approval, which may result in modifications or additions. NXP Semiconductors does not give any representations or warranties as to the accuracy or completeness of information included herein and shall have no liability for the consequences of use of such information.

Short data sheet — A short data sheet is an extract from a full data sheet with the same product type number(s) and title. A short data sheet is intended for quick reference only and should not be relied upon to contain detailed and full information. For detailed and full information see the relevant full data sheet, which is available on request via the local NXP Semiconductors sales office. In case of any inconsistency or conflict with the short data sheet, the full data sheet shall prevail.

17.3 Disclaimers

General — Information in this document is believed to be accurate and reliable. However, NXP Semiconductors does not give any representations or warranties, expressed or implied, as to the accuracy or completeness of such information and shall have no liability for the consequences of use of such information.

Right to make changes — NXP Semiconductors reserves the right to make changes to information published in this document, including without limitation specifications and product descriptions, at any time and without notice. This document supersedes and replaces all information supplied prior to the publication hereof.

Suitability for use — NXP Semiconductors products are not designed, authorized or warranted to be suitable for use in medical, military, aircraft, space or life support equipment, nor in applications where failure or

malfunction of a NXP Semiconductors product can reasonably be expected to result in personal injury, death or severe property or environmental damage. NXP Semiconductors accepts no liability for inclusion and/or use of NXP Semiconductors products in such equipment or applications and therefore such inclusion and/or use is at the customer's own risk.

Applications — Applications that are described herein for any of these products are for illustrative purposes only. NXP Semiconductors makes no representation or warranty that such applications will be suitable for the specified use without further testing or modification.

Limiting values — Stress above one or more limiting values (as defined in the Absolute Maximum Ratings System of IEC 60134) may cause permanent damage to the device. Limiting values are stress ratings only and operation of the device at these or any other conditions above those given in the Characteristics sections of this document is not implied. Exposure to limiting values for extended periods may affect device reliability.

Terms and conditions of sale — NXP Semiconductors products are sold subject to the general terms and conditions of commercial sale, as published at <http://www.nxp.com/profile/terms>, including those pertaining to warranty, intellectual property rights infringement and limitation of liability, unless explicitly otherwise agreed to in writing by NXP Semiconductors. In case of any inconsistency or conflict between information in this document and such terms and conditions, the latter will prevail.

No offer to sell or license — Nothing in this document may be interpreted or construed as an offer to sell products that is open for acceptance or the grant, conveyance or implication of any license under any copyrights, patents or other industrial or intellectual property rights.

17.4 Trademarks

Notice: All referenced brands, product names, service names and trademarks are the property of their respective owners.

18. Contact information

For additional information, please visit: <http://www.nxp.com>

For sales office addresses, send an email to: salesaddresses@nxp.com

19. Contents

1	General description	1
2	Features	1
3	Quick reference data	1
4	Ordering information	2
5	Functional diagram	2
6	Pinning information	3
6.1	Pinning	3
6.2	Pin description	3
7	Functional description	3
7.1	Function table	3
8	Limiting values	4
9	Recommended operating conditions	4
10	Static characteristics	5
11	Dynamic characteristics	6
11.1	Waveforms	6
12	Test information	7
13	Package outline	8
14	Soldering	10
14.1	Introduction to soldering	10
14.2	Wave and reflow soldering	10
14.3	Wave soldering	10
14.4	Reflow soldering	11
15	Abbreviations	12
16	Revision history	12
17	Legal information	13
17.1	Data sheet status	13
17.2	Definitions	13
17.3	Disclaimers	13
17.4	Trademarks	13
18	Contact information	13
19	Contents	14

Please be aware that important notices concerning this document and the product(s) described herein, have been included in section 'Legal information'.



© NXP B.V. 2007.

All rights reserved.

For more information, please visit: <http://www.nxp.com>

For sales office addresses, please send an email to: salesaddresses@nxp.com

Date of release: 9 August 2007

Document identifier: GTL2012_1

Looking for pricing, stock, or lifecycle information?

Click below to explore more details on WIN SOURCE:

- ⊖ [View GTL2012DP,118](#) on WIN SOURCE
- ⊖ [NXP / Nexperia](#) Information

Optimize Your Supply Chain with WIN SOURCE Solutions

- ✓ Global Sourcing Solution
- ✓ Obsolete Management
- ✓ Cost Control Management
- ✓ Shortage Management
- ✓ Alternative Solution
- ✓ Excess Inventory Management