

GM4BW63360A Light Emitting Diode

(Model Number: GM4BW63360A series)

Spec. Issue Date: January 18, 2006
Spec No: DG-061001

SHARP

SPEC. No. DS-0061001

ISSUE

REFERENCE

ELECTRONIC COMPONENTS GROUP

SHARP CORPORATION

SPECIFICATION

DEVICE SPECIFICATION FOR
LIGHT EMITTING DIODE

MODEL No.

GM4BW63360A

CUSTOMERS' APPROVAL

Date _____

By _____

PRESENTED

Date January 18, 2006

By *Y. Inada*

Y. Inada,
Department General Manager
A1249 Project Team
Electronic Components Group
SHARP CORPORATION

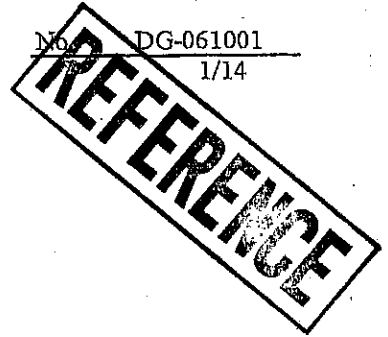

PRODUCT NAME Light Emitting Diode
MODEL No. GM4BW63360A

1. These specification sheets include materials protected under the copyright of Sharp Corporation ("Sharp"). Please do not reproduce or cause anyone to reproduce them without Sharp's consent.
2. When using this product, please observe the absolute maximum ratings and the instructions for use outlined in these specification sheets, as well as the precautions mentioned below. Sharp assumes no responsibility for any damage resulting from use of the product which does not comply with the absolute maximum ratings and the instructions included in these specification sheets, and the precautions mentioned below.

(Precautions)

- (1) This product is designed for use in the following application areas;

* OA equipment * Audio visual equipment * Home appliance
* Telecommunication equipment (Terminal) * Measuring equipment
* Tooling machines * Computers

If the use of the product in the above application areas is for equipment listed in paragraphs (2) or (3), please be sure to observe the precautions given in those respective paragraphs.

- (2) Appropriate measures, such as fail-safe design and redundant design considering the safety design of the overall system and equipment, should be taken to ensure reliability and safety when this product is used for equipment which demands high reliability and safety in function and precision, such as ;

* Transportation control and safety equipment (aircraft, train, automobile etc.)
* Traffic signals * Gas leakage sensor breakers * Rescue and security equipment
* Other safety equipment

- (3) Please do not use this product for equipment which require extremely high reliability and safety in function and precision, such as ;

* Space equipment * Telecommunication equipment (for trunk lines)
* Nuclear power control equipment * Medical equipment

- (4) Please contact and consult with a Sharp sales representative if there are any questions regarding interpretation of the above three paragraphs.

3. Please contact and consult with a Sharp sales representative for any questions about this product.

SHARPGM4BW63360A specification

1. Application

This specification applies to the light emitting diode device Model No. GM4BW63360A.
[White (from InGaN Blue LED chip + Yellow Phosphor) LED device]

2. Outline dimensions and terminal connections ----- Refer to the attached sheet Page 3.

3. Ratings and characteristics ----- Refer to the attached sheet Page 4. ~ 6.

- 3-1. Absolute maximum ratings
- 3-2. Electro-optical characteristics
- 3-3. Derating Curve
- 3-4. Characteristics Diagram

4. Reliability ----- Refer to the attached sheet Page 7.

- 4-1. Test items and test conditions
- 4-2. Failure judgment criteria

5. Quality level ----- Refer to the attached sheet Page 8.

- 5-1. Inspection method
- 5-2. Description of inspection and criteria

6. Supplement ----- Refer to the attached sheet Page 9. ~ 12.

- 6-1. Taping
- 6-2. Packing Specification
- 6-3. Label
- 6-4. Environment
- 6-5. Rank

7. Precautions for use ----- Refer to the attached sheet Page 13. ~ 14.

- 7-1. Precautions matters for designing circuit
- 7-2. Soldering
- 7-3. Cleaning method

REFERENCE

SHARP

2. Outline dimensions and terminal connections

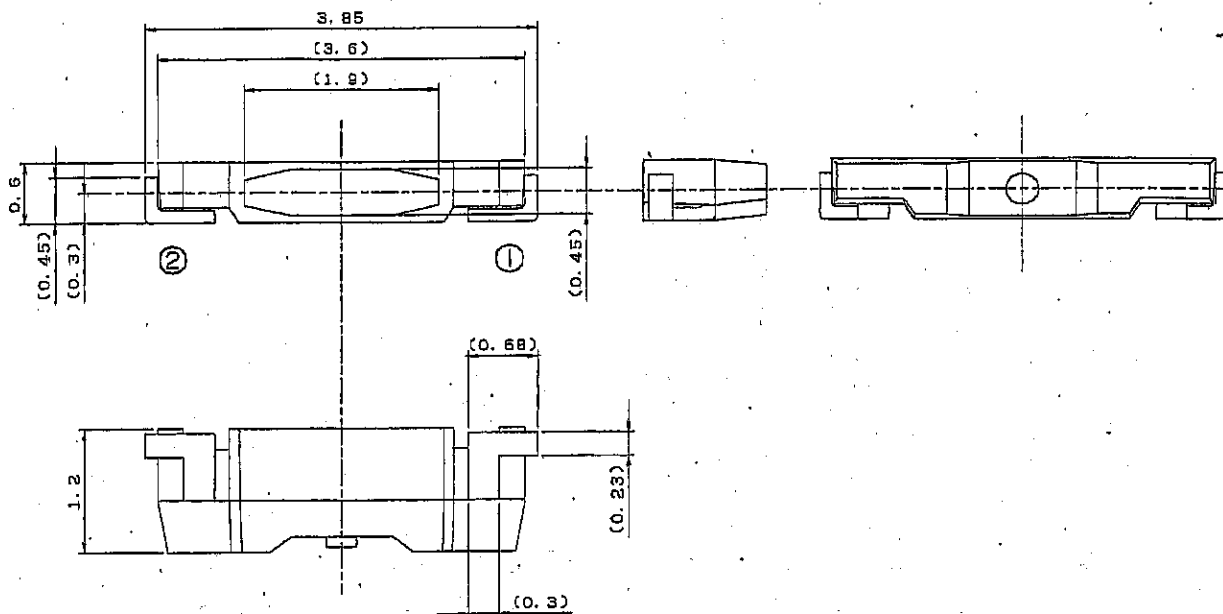

1. Pin Connection

①	Anode
②	Cathode

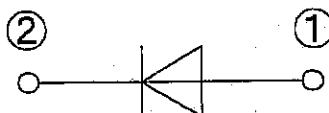

2. Tolerance : ±0.1mm

unit	Material	Finish	Drawing No.
mm	Frame: Copper alloy Package: Nylon + Silicone	Ag plate	51801001

SHARP

3. Ratings and characteristics

3-1. Absolute maximum ratings

(Ta=25°C) (*3)

Parameter	Symbol	Rating	Unit
Power dissipation	P	93	mW
Continuous forward current	I _F	25	mA
Peak forward current(*1)	I _{FM}	80	mA
Derating factor	DC	-0.53	mA/°C
	Pulse	-1.07	mA/°C
Reverse voltage	V _R	5	V
Operating temperature(*3)	Topr	-30 to +85	°C
Storage temperature	T _{stg}	-40 to +100	°C
Soldering temperature (*2)	T _{sol}	260	°C

(*1) Duty ratio = 1/10, Pulse width = 0.1ms

(*2) For reflow soldering (Max.10s)

(*3) Ta and Topr mean atmospheric temperature near surface of the device when the device does not operate.

3-2. Electro-optical characteristics

(Ta=25°C)

Parameter	Symbol	Condition	MIN.	TYP.	MAX.	Unit
Forward Voltage	V _F		-	3.2	3.7	V
Luminous intensity(*4)	I _v	I _F =20 mA	1200	(1550)	2050	mcd
Chromaticity(*5)	x		-	0.30	-	-
	y		-	0.29	-	-
Reverse Current	I _R	V _R =4V	-	-	50	μA

(*4) Measured by EG&G MODEL550(Radiometer/Photometersystem)

(Measurement accuracy : ±10%)

(*5) Measured by Ohtsuka electronics MODEL MCPD-2000

(Measurement accuracy : x,y:±0.01)

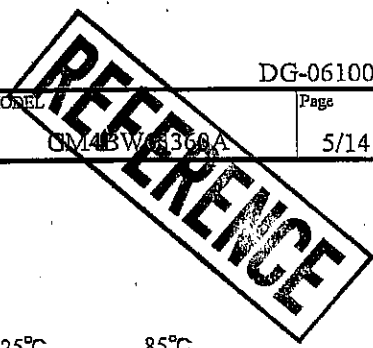

3-3. Derating Curve

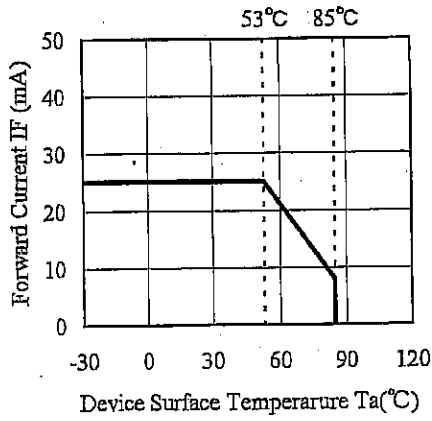

Forward Current Derating Curve

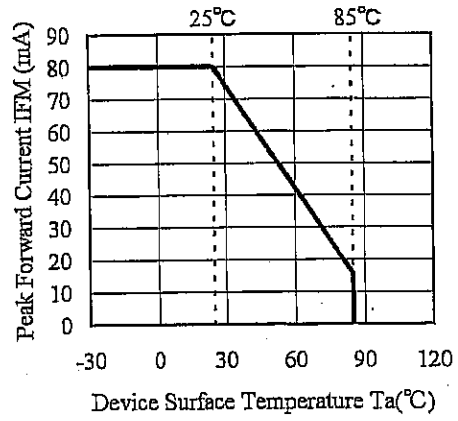

Peak Forward Current Derating Curve

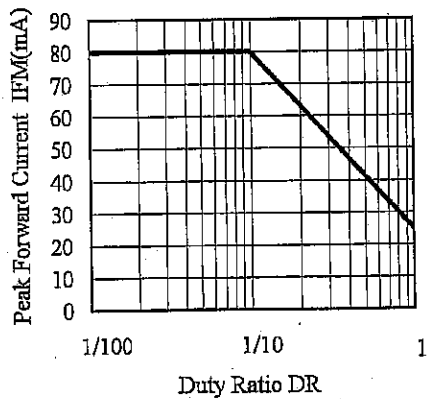

Peak Forward Current vs Duty Ratio ($T_a = 25^\circ\text{C}$)

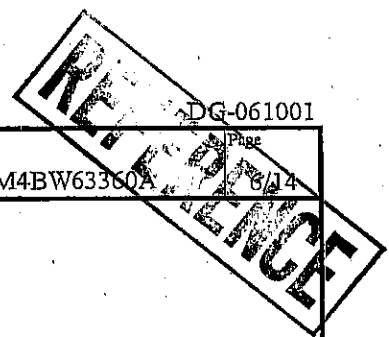

3-4. Characteristics Diagram (*1)

Relative Luminous Intensity vs. Forward Current

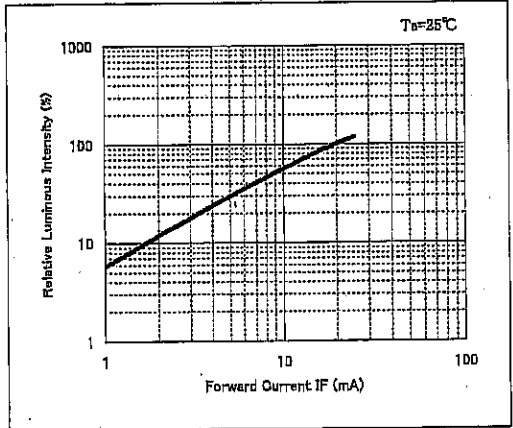

Chromaticity Coordinate vs. Forward Current

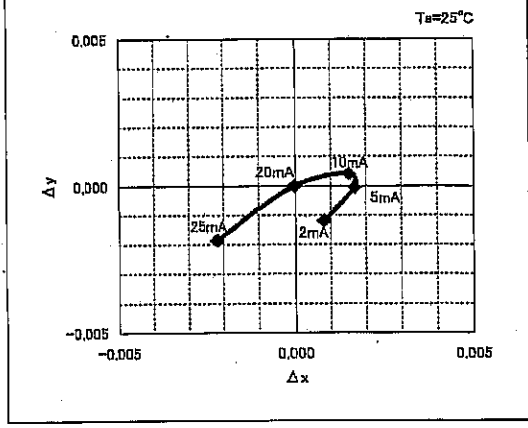

Relative Luminous Intensity vs. Device Surface Temperature

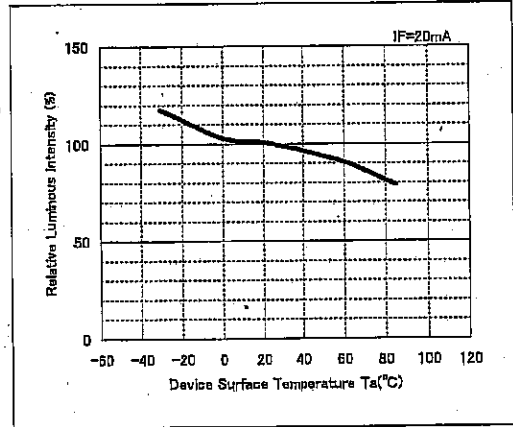

Chromaticity Coordinate vs. Device Surface Temperature

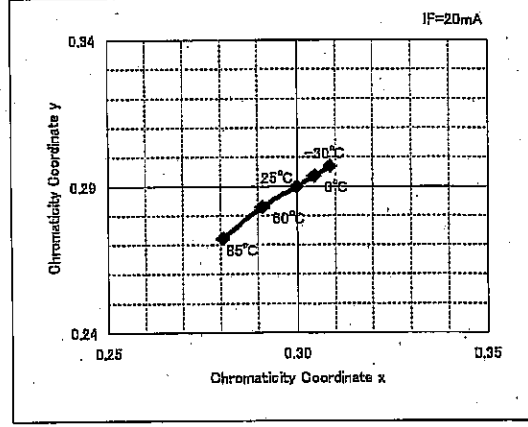

Forward Voltage vs. Forward Current

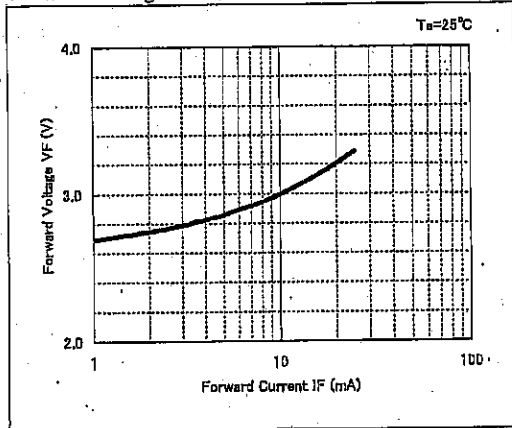

Forward Voltage vs. Device Surface Temperature

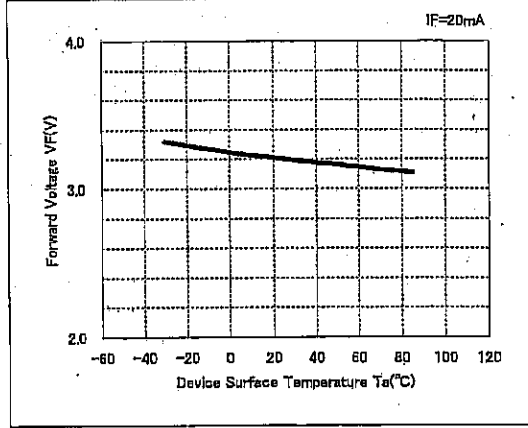

(*1) Above characteristics data are typical data and not a guaranteed data

SHARP**REFERENCE**

4. Reliability

The reliability of products shall be satisfied with items listed below.

4-1. Test items and test conditions

Confidence level: 90%

No.	Test items	Test conditions	Samples n	Defective C	LTPD (%)
1	Temperature cycle	-40 °C(30 min)~+100 °C(30 min), 30 times	22	0	10
2	High temp and high humidity storage	Ta=+60°C, RH=90%, t=1000h	22	0	10
3	High temperature storage	Ta= +100°C, t=1000h	22	0	10
4	Low temperature storage	Ta= -40 °C, t=1000h	22	0	10
5	Operating test	Ta=25 °C, IF=25 mA, t=1000h	22	0	10
6	Mechanical shock test	15000 m/s ² , 0.5 ms ±X·±Y·±Z direction, 3 times	11	0	20
7	Variable frequency vibration	200 m/s ² , 100~2 000~100 Hz / sweep for 4 min. X·Y·Z direction, 4 times	11	0	20
8	Soldering heat	Refer to the attached sheet, Page 13. , 2 times	11	0	20
9	Solder ability (Dip Method)	240±5°C, 5±1s (Solder/Flux : M705/ESR250 (SENJU METAL INDUSTRY	11	0	20

4-2. Failure judgment criteria (*1)

(Ta=25°C)

No.	Parameter	Symbol	Condition	Failure judgment criteria (*2)
1	Forward voltage	V _F	I _F =20 mA	V _F > U.S.L × 1.2
2	Reverse current	I _R	V _R =4V	I _R > U.S.L × 2.0
3	Luminous intensity	I _V	I _F =20 mA	I _V < Initial value × 0.5, I _V > Initial value × 2.0

*1 : Measuring condition is accordance with this specification.

*2 : U.S.L. is shown by Upper Specification Limit.

- Solder ability Solder shall be adhere at the electrode area of 90% or more after dipping.

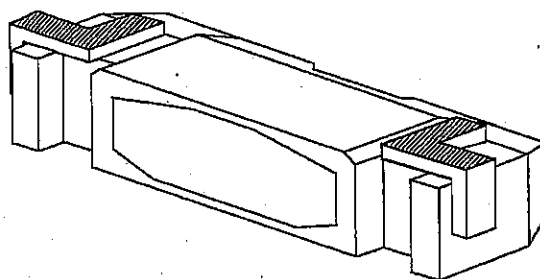

REFERENCE

SHARP

5. Quality level

5-1. Inspection method

A single sampling plan, normal inspection S-4 based on ISO 2859-1 shall be adopted.

5-2. Description of inspection and criteria

No.	Inspection items	Criteria	Defect	AQL
1	Emission	No emission	Major defect	0.1%
2	Taping	Product inserted in reverse direction		
3	Electro-optical characteristics	Not conforming to the specification (Forward voltage, Reverse current, Luminous intensity)	Minor defect	0.4%
4	Outline dimensions	Not conforming to the specification (vertical size , horizontal size and thickness)		
5	Appearance	<ul style="list-style-type: none"> ·Dust and scratch on emission area (obstacle to emission) ·Resin burr over the tolerance of out line dimensions ·Chipping of resin and electrode : 0.3mm or more 		

BG-061001

MODEL No.
GM4BW63360A

REFERENCE

SHARP

6. Supplement

6-1. Taping

6-1-1. Shape and dimension of tape (Ref.)

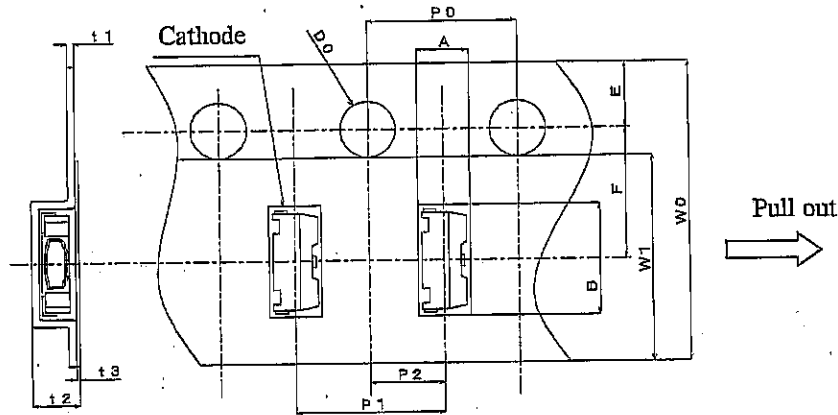

Parameters	Symbols	Dimensions [mm](Typ.)	Remarks
Concave square hole for part insertion	Vertical	A	1.4
	Horizontal	B	4.0
	pitch	P ₁	4.0
Round sprocket hole	Diameter	D ₀	1.5
	Pitch	P ₀	4.0
	Position	E	1.75
Center to center dimension	Vert.dir.	P ₂	2.0
	Hori.dir.	F	5.5
Cover tape	Width	W ₁	9.5
	Thickness	t ₃	0.1
Carrier tape	Width	W ₀	12.0
	Thickness	t ₁	0.3
Thickness of the entire unit	t ₂	1.15	With cover tape and carrier tape combined

6-1-2. Shape and dimension of reel (Ref.)

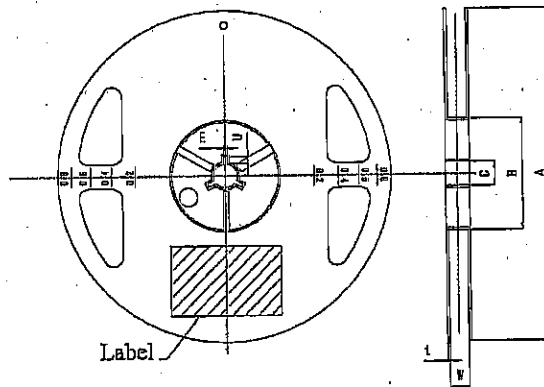

Parameters	Symbols	Dimensions [mm](Typ.)	Remarks
Flange	Diameter	A	φ180
	Thickness	t	1.1
	Inner space direction	W	13
Hub	External diameter	B	φ60
	Spindle hole diameter	C	φ13
	Key slit	Width	E
Depth		U	4.5

Notation for part name etc. Labelling on one side of flange. (part name, quantity, lot No.)

※Material : Reel...Polystyrene

REFERENCE



6-1-3. Taping specification

(1) Lead tape : Conformity standard JIS C0806

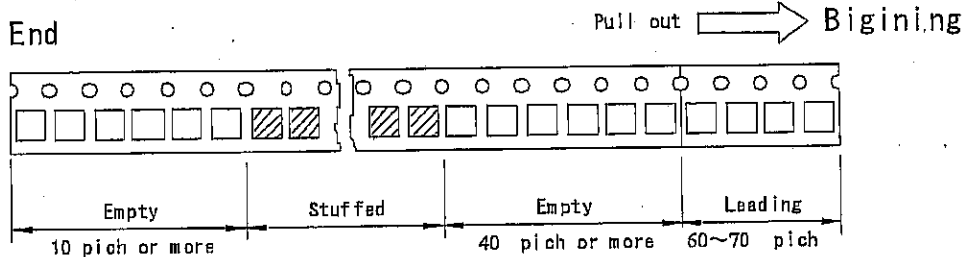

(2) Cover tape strength against peeling: $F=0.1\sim0.8$ N ($\theta=10^\circ$ or less)

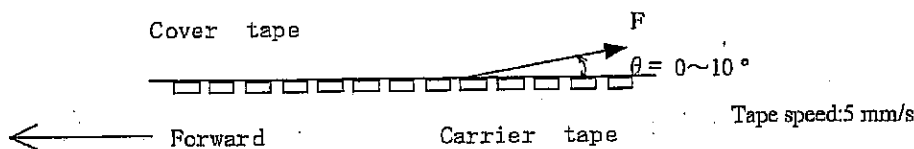

(3) Tape strength against bending:

The radius of bending circle should be 30 mm or more.

If it is less than 30 mm, the cover may peel.

(4) Jointing of tape: There should not be joint of cover tape or carrier tape.

(5) Quantity per reel: Average 5,000 pcs. per reel

(6) Product weight: Approx. 4.0 mg

- (7) Others:
- ① There should not be missing above continuous two products.
 - ② The lacking quantity of the products should be less than 0.1% of total product quantity.
 - ③ Products should be easily taken out.

6-2. Packing specification

6-2-1. Moisture proof package

In order to avoid the absorption of humidity in transport and storage, the devices are packed in aluminum moisture proof package.

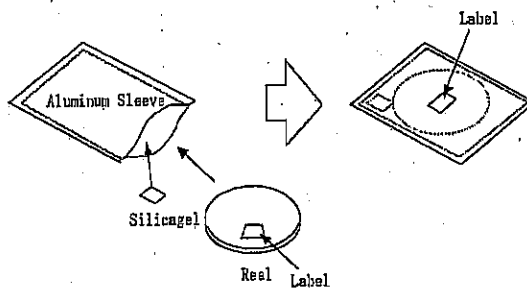

6-2-2. Strage conditions

Temperature : 5 to 30°C Humidity : less than 60%RH

6-2-3. Treatment after opening

- (1) The LEDs should be kept at 30°C or less and 60%RH or less. The LEDs should be soldered within 72 hours (3days) after opening package.
- (2) In case the devices are not used for a long time after opening, the storage in dry box is recommendable. Or it is better to repack the devices with a desiccative by the sealer and put them in the some storage conditions as 6-2-2.
- (3) If unused term is exceeded the storage time, baking treatment should be performed.

*Baking treatment :

- ① In taping : 60°C to 65°C, 36 to 48 hours
- ② In loose end : Temperature: 100°C to 120°C, Time: 2 to 3 hours (on PWB or metallic tray)

SHARP

6-3. Label

SHARP CORPORATION	
PART No.	GM4BW63360A
QUANTITY	5000
[EIAJ C-3 Bar code]	
[EIAJ C-3 Bar code]	
LOT No.	KA01A01 RANK Db51
(EIAJ C-3) MADE IN PHILIPPINES	

- ← Model number
 ← Quantity of products
 ← EIAJ C-3 Bar code
 ← EIAJ C-3 Bar code
 ← Lot number / Rank
 ← Production country

Lot Number

K A 0 1 A 0 1
 ① ② ③ ④ ⑤

- ① Production plant code (to be indicated alphabetically)
 ② Production lot (single or double figures)
 ③ Year of production (the last two figures of the year)
 ④ Month of production
 (to be indicated alphabetically with January corresponding)
 ⑤ Date of production (01~31)

Rank

D b51
 ① ②

- ① Luminous intensity rank
 ② Color rank

6-4. Environment

6-4-1. Ozone destructive chemicals.

- (1) The device doesn't contain following chemicals.
 (2) The device doesn't have a production line whose process requires following chemicals.
 Banned chemicals : CFCs, halones, CCl₄, Trichloroethane (Methylchloroform)

6-4-2. Bromic non-burning materials

The device doesn't contain bromic non-burning materials (PBBOs, PBBs)

REFERENCE

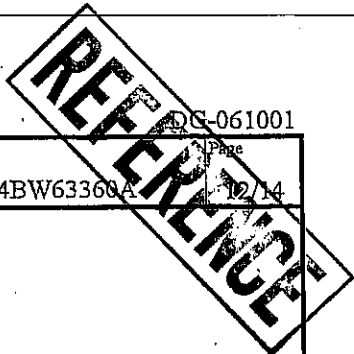

SHARP

6-5. Rank

6-5-1. Luminous intensity rank table (*1)

($I_f=20\text{mA}$, $T_a=25^\circ\text{C}$)

Rank	Luminous Intensity		Unit
D	1200	~ 1440	mcd
E	1440	~ 1720	
F	1720	~ 2050	

(*1) The quantity-ratio of the ranks are decided by Sharp. (measurement accuracy : $\pm 10\%$)

6-5-2. Color rank table (*2)

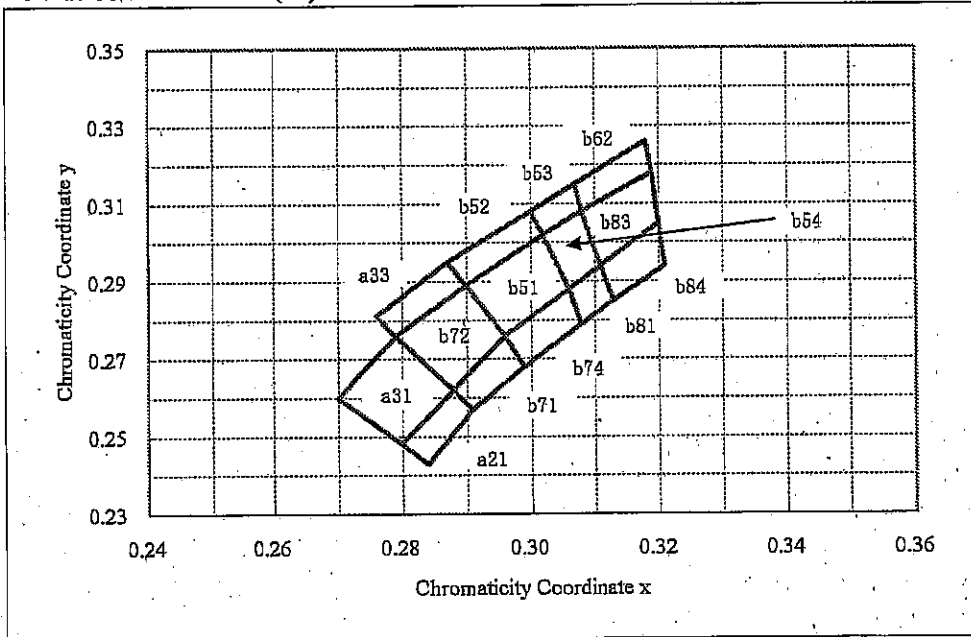

($I_f=20\text{mA}$, $T_a=25^\circ\text{C}$)

Rank	Point 1		Point 2		Point 3		Point 4	
	x	y	x	y	x	y	x	y
a21	0.284	0.243	0.280	0.248	0.288	0.262	0.291	0.257
a31	0.280	0.248	0.270	0.260	0.279	0.276	0.288	0.262
a33	0.279	0.276	0.276	0.281	0.287	0.295	0.290	0.289
b71	0.291	0.257	0.288	0.262	0.296	0.276	0.299	0.268
b72	0.288	0.262	0.279	0.276	0.290	0.289	0.296	0.276
b74	0.299	0.268	0.296	0.276	0.306	0.288	0.308	0.279
b51	0.296	0.276	0.290	0.289	0.302	0.302	0.306	0.288
b52	0.290	0.289	0.287	0.295	0.300	0.308	0.302	0.302
b53	0.302	0.302	0.300	0.308	0.307	0.315	0.308	0.308
b54	0.306	0.288	0.302	0.302	0.308	0.308	0.311	0.294
b81	0.308	0.279	0.306	0.288	0.311	0.294	0.313	0.285
b83	0.311	0.294	0.308	0.308	0.319	0.318	0.320	0.305
b84	0.313	0.285	0.311	0.294	0.320	0.305	0.321	0.294
b62	0.308	0.308	0.307	0.315	0.318	0.326	0.319	0.318

(*2) The quantity-ratio of the ranks are decided by Sharp. (measurement accuracy : ± 0.01)

SHARP

7. Precautions for use

7-1. Precautions matters for designing circuit

- When designing a circuit, please make sure that not to give a reverse voltage to the LED.
- There is a case that LED to be damaged with external stresses since the devices very small. Please make sure that not to give any hard shock to the LED.
- Blue chip LED and fluorescent materials are used as luminescent materials.
Please note there is possibility to have color change in some degree depended on applied current.
- Please note there is possibility to damage your eyes when person look LED in face for long time.
- During processing, mechanical stress on the surface should be minimized as much as possible. Sharp objects of all types should not be used to pierce the sealing compound.
- When populating boards in SMT production, there are basically no restrictions regarding the form of the pick and place nozzle, except that mechanical pressure on the surface of the resin must be prevented.
- Static electricity or surge voltage damages the LEDs. It is recommended that a wrist band or anti-electrostatic glove be used when handling the LEDs. All devices, equipment and machinery must be grounded.

7-2. Soldering

- The LEDs can be soldered in place using the reflow soldering method once and twice. Please avoid assemble using the dip soldering method.
Occasionally there is a brightness decrease caused by the influence of heat or ambient atmosphere during air reflow. It is recommended that the User use the nitrogen reflow method.

7-2-1. Reflow soldering

- (1) It is not recommended to exceed the soldering temperature and time shown below.
Caused by substrate bend or the other mechanical stress during reflow soldering may happen gold wire disconnection etc. Therefore please check and study your solder reflow machine's best condition.
- (2) In case of 2 times reflow process, 2nd reflow process should be done within 3 days after opening package. (Storage condition ; at 30°C, RH less than 60%RH)
- (3) LED electrode and leadframe are comprised of a silver plated copper alloy. The silver surface may be attacked by environments which contain corrosive gases and so on.
Please avoid conditions which may cause the LED to corrode, tarnish or discolor.
This corrosion or discoloration might lower solderability or might affect on optical characteristics.
- (4) Reflow soldering temperature profile
Use the conditions shown to the under figure.
✳After reflow soldering, rapid cooling should be avoided.

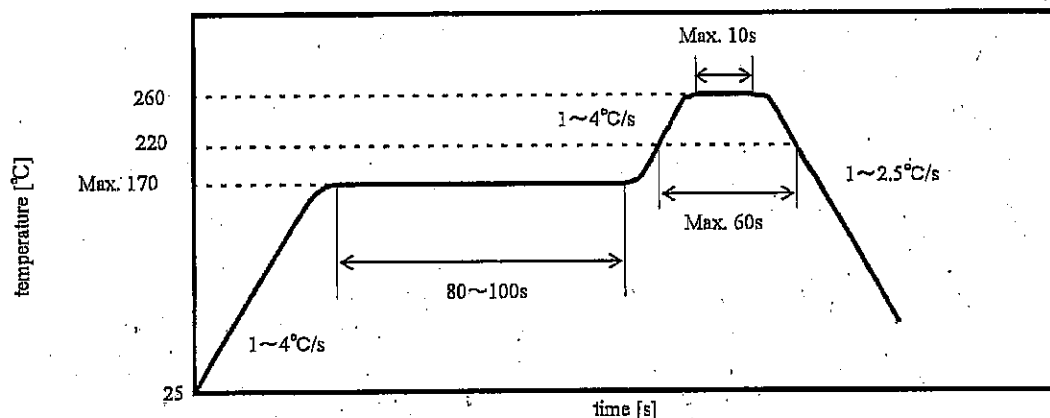

Fig. Reflow soldering temperature profile

REFERENCE

SHARP

(5) The cautions at the time of re-reflow process

Please setup reflow process fundamentally to complete at once.

When you perform the second round reflow soldering reluctantly, please carry out promptly after completing the 1st time.

(6) The reverse side dip soldering process of the substrate after reflow soldering

In case of dip soldering process of reverse side to reflow soldering side for designing, the reverse side dipping first, and reflow soldering after, to reduce mechanical stress caused by dip soldering heat or substrate bend.

7-2-2. Hand soldering (with soldering iron)

Please proceed to use soldering iron within 290°C max / 3sec.

In case if you proceed within 1 hour taking out from Aluminum Package, and not touching to the terminals of the Device(Operation at ; under 30degree/60%RH or less) , it is usable under 350°C max. / 3sec. as the option.

※ In case over 1hour after opening the Aluminum package, we recommend to proceed baking treatment before the use.

7-2-3. Recommended solder pattern

Recommend 0.1 mm to 0.2 mm thickness metal mask for screen print.

Caused by solder reflow condition, solder paste, substrate and the other material etc., may change solderbility.

Please check and study actual solderbility before usage.

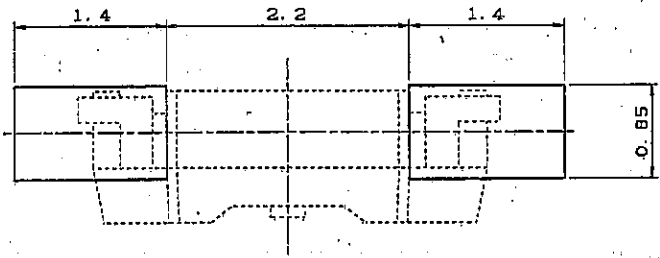

Unit : mm

7-3. Cleaning method

Use no-clean solder and do not clean because solvent may dissolve the package and the resin. And do not clean the LED's by the ultrasonic.

Looking for pricing, stock, or lifecycle information?

Click below to explore more details on WIN SOURCE:

- ⊖ [View GM4BW63360A on WIN SOURCE](#)
- ⊖ [Sharp Microelectronics Information](#)

Optimize Your Supply Chain with WIN SOURCE Solutions

- ✓ Global Sourcing Solution
- ✓ Obsolete Management
- ✓ Cost Control Management
- ✓ Shortage Management
- ✓ Alternative Solution
- ✓ Excess Inventory Management