



**THE DATASHEET OF
GA1A1S201WP**



SHARP

OPTO-ANALOG DEVICES DIVISION
ELECTRONIC COMPONENTS GROUP
SHARP CORPORATION

SPECIFICATION

REFERENCE

DEVICE SPECIFICATION FOR

OPIC LIGHT DETECTOR

MODEL No.

GA1A1S201WP

Specified for _____

Enclosed please find copies of the Specifications which consists of 14 pages including cover.
After confirmation of the contents, please be sure to send back copy of the Specifications
with approving signature on each.

CUSTOMER'S APPROVAL

DATE

BY

PRESENTED

DATE

BY

H. O

H. Ogura,
Department General Manager of
Engineering Dept., III
Opto-Analog Devices Div.
ELECOM Group
SHARP CORPORATION

Product name : OPIC LIGHT DETECTOR

Model No. : GA1A1S201WP

1. These specification sheets include materials protected under copyright of Sharp Corporation ("Sharp"). Please do not reproduce or cause anyone to reproduce them without Sharp's consent.
2. When using this product, please observe the absolute maximum ratings and the instructions for use outlined in these specification sheets, as well as the precautions mentioned below. Sharp assumes no responsibility for any damage resulting from use of the product which does not comply with the absolute maximum ratings and the instructions included in these specification sheets, and the precautions mentioned below.

(Precautions)

- (1) This product is designed for use in the following application areas ;

(· OA equipment · Audio visual equipment · Home appliances)
(· Telecommunication equipment (Terminal) · Measuring equipment)
(· Tooling machines · Computers etc.)

If the use of the product in the above application areas is for equipment listed in paragraphs (2) or (3), please be sure to observe the precautions given in those respective paragraphs.

- (2) Appropriate measures, such as fail-safe design and redundant design considering the safety design of the overall system and equipment, should be taken to ensure reliability and safety when this product is used for equipment which demands high reliability and safety in function and precision, such as ;

(· Transportation control and safety equipment (aircraft, train, automobile etc.))
(· Traffic signals · Gas leakage sensor breakers · Rescue and security equipment)
(· Other safety equipment etc.)

- (3) Please do not use this product for equipment which require extremely high reliability and safety in function and precision, such as ;

(· Space equipment · Telecommunication equipment (for trunk lines))
(· Nuclear power control equipment · Medical equipment etc.)

- (4) Please contact and consult with a Sharp sales representative if there are any questions regarding interpretation of the above three paragraphs.

3. Please contact and consult with a Sharp sales representative for any questions about this product.

1. Application
This specification applies to the outline and characteristics of Silicon OPIC light detecting device Model No. GA1A1S201WP.
2. Outline
Refer to the attached drawing No. CY13631L02.
3. Ratings and characteristics
Refer to the attached sheet, page 4.
4. Reliability
Refer to the attached sheet, page 5.
5. Outgoing inspection
Refer to the attached sheet, page 6.
6. Supplement
 - (6-1) Circuit block diagram
Refer to the attached sheet, page 7.
 - (6-2) Packing specifications shall be referred to attached drawing.
 - (6-3) This product is not designed against electromagnetic and ionized-particle irradiation.
 - (6-4) This product shall not contain the following materials.
Also, the following materials shall not be used in the production process for this product.
Materials for ODS : CFCs, Halon, Carbon tetrachloride
1.1.1-Trichloroethane (Methyl chloroform)
 - (6-5) This product does not contain the chemical materials regulated by RoHS.
 - (6-6) This product does not contain specific brominated flame retardants such as the PBB and PBDE .
 - (6-7) Product mass (Piece): Approximately 3.5mg
7. Notes
 - (7-1) By-pass capacitors
In order to stabilize power supply line, connect some by-pass capacitors of 0.01 μ F or more between Vcc and GND within 5mm from lead pins.
 - (7-2) Cleaning conditions :
Solvent cleaning : Solvent temperature 45 $^{\circ}$ C or less Immersion for 3 min or less
Ultrasonic cleaning : The effect to device by ultrasonic cleaning differs by cleaning bath size, ultrasonic power output, cleaning time, PCB size or device mounting condition etc.
Please test it in actual using condition and confirm that doesn't occur any defect before starting the ultrasonic cleaning.
The cleaning shall be carried out with solvent below.
Solvent : Ethyl alcohol, Methyl alcohol, Isopropyl alcohol
 - (7-3) Soldering
 - (7-3-1) Solder reflow
Please do two times or less soldering at the temperature and the time within the temperature profile in attached sheet-1.
 - (7-3-2) Soldering by hand
To solder onto lead pins, please solder at 320 $^{\circ}$ C for 3 seconds or less using soldering iron 50W or less.
Please be careful not to give the mechanical force to the package when soldering because it may cause the deformation or defect due to the plated connection.
 - (7-3-3) Case of other soldering
Other soldering methods such as dip soldering and VPS should not be used.
Please use (7-3-1) or (7-3-2).

3. Ratings and characteristics

3.1 Absolute maximum ratings

Ta = 25°C

Parameter	Symbol	Rating	Unit
Supply voltage	V _{CC}	-0.3 to +7.0	V
Output current	I _O	1	mA
Operating temperature	T _{Opr}	-40 to +85	°C
Storage temperature	T _{Stg}	-40 to +85	°C
Soldering temperature*	T _{Sol}	250	°C

* Within 10s and two times (MAX) according to the attached reflow profile

3.2 Recommended operating conditions

(Condition: Ta = 0 to 70°C)

Parameter	Symbol	MIN.	MAX.	Unit
Operating supply voltage	V _{CC}	2.3	3.2	V
Dynamic range	D	3	55000	1x

3.3 Electro-optical characteristics

Ta = 25°C, V_{CC} = 2.9V

Parameter	Symbol	Condition	MIN.	TYP.	MAX.	Unit
Supply current	I _{CC}	E _V = 1000lx	40	70	150	μA
Output current *1,*2	I _{O1}	E _V = 100lx	16	20	24	μA
	I _{O2}	E _V = 1000lx	27	30	33	μA
	I _{O3}	E _V = 0lx	-	-	1	μA
Temperature Coefficient	α1	-30°C - +70°C, E _V = 50 to 55000lx	-	-	0.25	%/°C
	α2	0°C - +50°C, E _V = 50 to 55000lx	-	-	0.2	%/°C
Peak sensitivity	λ _P	-	-	555	-	nm
Rise time (10%-90%) *3	tr1	E _V = 50 to 55000lx	-	-	150	us
	tr2	Ta = -30 to +70°C	-	-	5	ms
Fall time (10%-90%) *3	tf1	E _V = 50 to 55000lx	-	-	150	us
	tf2	Ta = 0 to +50°C	-	-	15	ms
Output current difference	ΔI	I _O (incandescent lamp E _V = 100lx) - I _O (fluorescent lamp E _V = 100lx) *4	-2	-	2	μA

*1: E_V: Illuminance by CIE standard light source A (tungsten lamp)

*2: Sensor output vs. illuminance is logarithmic.

$$I_O = 10 \times \log(E_V) \text{ (uA)}$$

*3: Illuminance by white LED.

*4: White LED is used on mass production line instead of fluorescent lamp.

4. Reliability

The reliability of products shall satisfy items listed below.

Confidence level : 90%

LTPD : 10 or 20

Test Items	Test Conditions	Failure Judgment Criteria	Samples (n)
			Defective(C)
Temperature cycling	1 cycle -40°C \longleftrightarrow +85°C (30min) (30min) 20 cycles test	$I_{CC} < L \times 0.8$ $I_{CC} > U \times 1.2$ $I_{O1} < L \times 0.8$ $I_{O1} > U \times 1.2$ $I_{O2} < L \times 0.8$ $I_{O2} > U \times 1.2$ U: Upper specification limit L: Lower specification limit	n=22, C=0
High temp. and high humidity storage	+60°C, 90%RH, 500h		n=22, C=0
High temp. storage	+85°C, 500h		n=22, C=0
Low temp. storage	-40°C, 500h		n=22, C=0
Operation test	$V_{CC}=3.2V$, $T_a=+25^\circ C$, $E_v=3000lx$ 500h		n=22, C=0
Mechanical shock	1000m/s ² , 6ms, Half sine wave 3 times/ $\pm X$, $\pm Y$, $\pm Z$ direction		n=11, C=0
Variable frequency vibration	200m/s ² 100 to 2000 to 100Hz / Sweep for 4min 48min/X, Y, Z direction		n=11, C=0
Soldering heat	250°C, 10 s, 2 times The temperature profile is according to the precautions for soldering (attachment-1).		n=11, C=0

5. Outgoing inspection

(1) Inspection lot

Inspection shall be carried out per each delivery lot.

(2) Inspection method

A single sampling plan, normal inspection level II based on ISO2859 shall be adopted.

Parameter	Inspection items and test method					AQL(%)	
Major defect	1	Disconnection, short				0.1	
	2	Inverse polarity on terminal					
	3	Characteristics defect					
		Parameter	Symbol	Judgment criteria			Unit
				MIN.	MAX.		
		Consumption current	I _{CC}	40	150		μA
		Output current 1	I _{O1}	16	24		μA
Output current 2	I _{O2}	27	33	μA			
Output current 3	I _{O3}	-	1	μA			
Measurement conditions are described in 3.3.							
Minor defect	1	Appearance defect				0.25	
		Parameter	Judgment criteria				
	Crack	Visible crack irrespective of its position shall be defect.					
	Split, Chip, Scratch, Stain, Blur Bubble, Foreign matter (One on resin surface which can wipe off shall not be applied.)	One which affects the characteristics of paragraph 3.3 shall be defect.					

6. Supplement

(6-1) Circuit block diagram

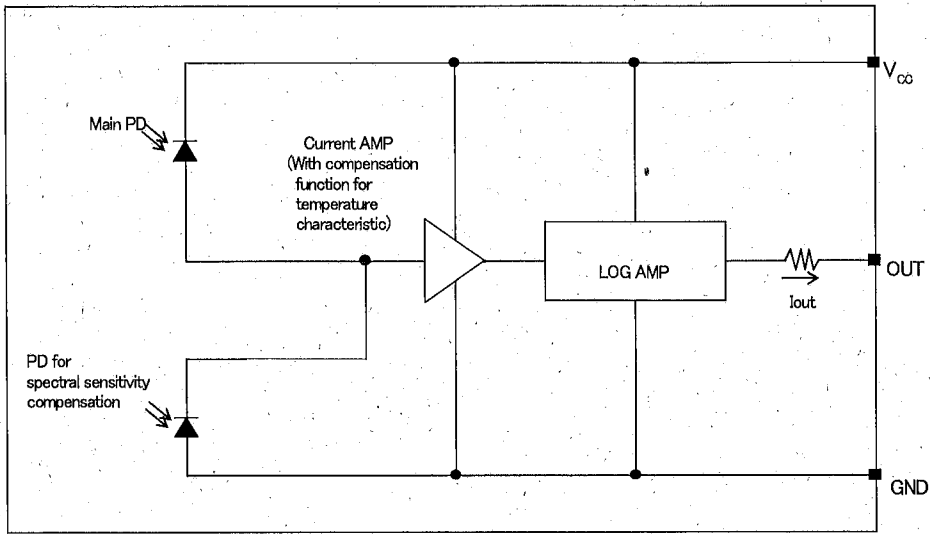

(6-2) Output Current Characteristic

Output Current Characteristics (TYP.)

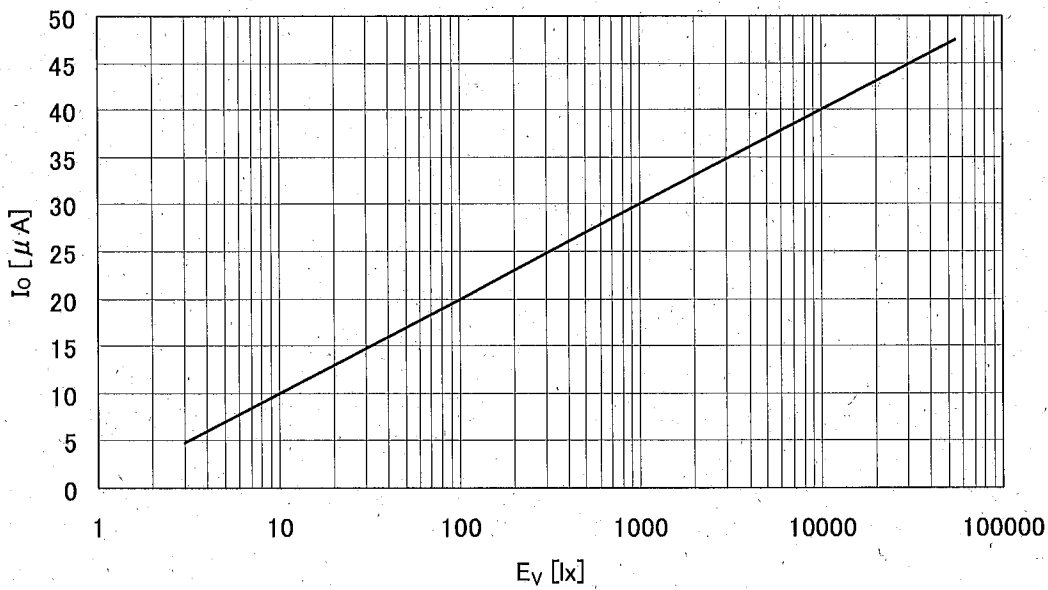

4 Packaging

4-1 Inner packing

① Inner packing drawing

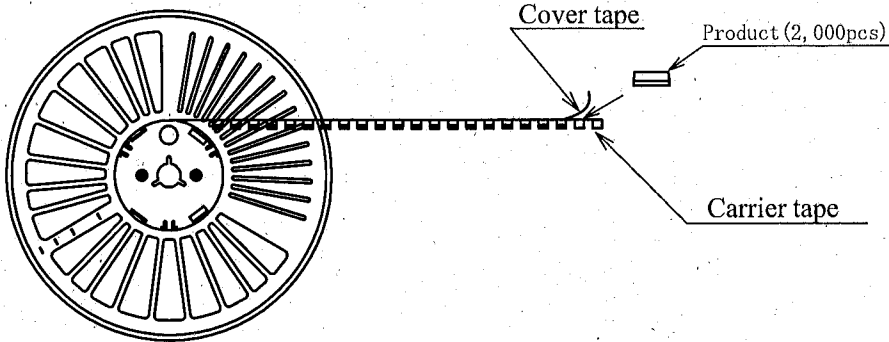

② Inner packing material: Reel(PPE), Carrier tape(PC), Cover tape(PET)

③ Quantity: 2,000pcs./reel

4-2 Outer packing

① Outer packing drawing

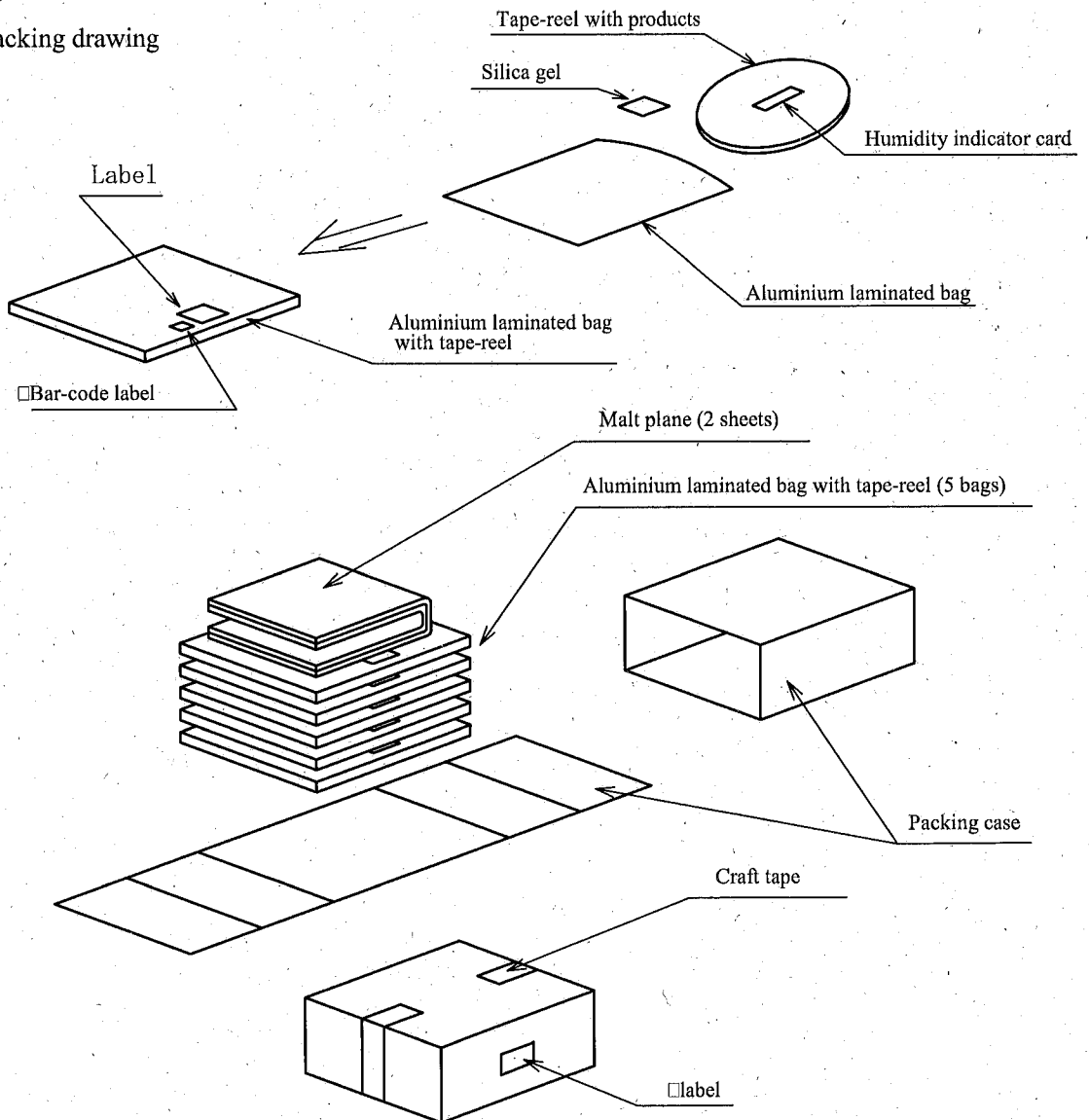

② Outer packing material: Packing case(Corrugated cardboard), Malt plane(Urethane)

Aluminium laminated bag (Alumi-Polyethylene)

Humidity indicator card (paper), Label(paper), silica gel, craft tape

③ Quantity: 10,000pcs./box

④ Indication: Model No., quantity and inspection date

⑤ Regular packaged mass: Approximately 600g

3. Storage and management after open

3.1 Storage condition : Storage shall be in accordance with the below conditions.

Storage temp. : 5 to 30°C

Storage humidity : 70%RH or less

3.2 Treatment after open

(1) After open, please mount at the conditions of humidity 60%RH or less and temperature 5 to 25°C within 3 days.

(2) In case of long time storage after open, please mount at the conditions of humidity 70%RH or less and temperature 5 to 30°C within 2 weeks by using dry box (humidity 20% or less, temperature 5 to 25°C) or resealing with desiccant in moisture-proof sack by sealer.

3.3 Baking before mounting

In case that it could not be carried out the above treatment, it is able to mount by baking treatment.

However baking treatment shall be limited only 1 time.

Recommended conditions : 125°C, 16 to 24 hours

Recommended conditions at the packaged condition by the reel : 65°C, 48 hours

※ In the case baking at the packaged condition, please hang the reel on the oven using the spindle through the center hole. Please do not put the reel across the oven.

Package specifications (ϕ 180mm reel)

1. Application

This specification applies to the taping specifications and the relation items for the GA1A1S201WP.

2. Taping method

(2.1) Tape structure and Dimensions (Refer to the attached sheet-2-2)

The tape shall have a structure in which a cover tape is sealed heat-pressed on the carrier tape made by electrically conductive polycarbonate to protect against static electricity.

(2.2) Reel structure and Dimensions (Refer to the attached sheet-2-3)

(2.3) Direction of product insertion (Refer to the attached sheet-2-3)

Product direction in carrier tape shall direct to the detecting part at the hole side on the tape.

(2.4) Inclusion correction

In case correcting inclusion failing products, these products can be cut out from the carrier tape and the cutting parts can be sealed. At this time, the products are not included at the same places.

3. Adhesiveness of cover tape

The exhalation force between carrier tape and cover tape shall be 0.1N to 1N for the angle from 160° to 180° .

4. Rolling method and quantity

Wind the tape back on the reel so that the cover tape will be outside the tape.

Attach more than 16cm of blank tape to the trailer and 40cm to the leader of the tape and fix the both ends with adhesive tape.

One reel shall contain 2000 pcs, but in the case products are cut out, the number is less.

5. Marking

The outer packaging case shall be marked with following information.

* Model No. * Number of pieces delivered * Production date

6. Safety protection during shipping

There shall be no deformation of component or degradation of electrical characteristics due to shipping.

Tape structure and Dimensions

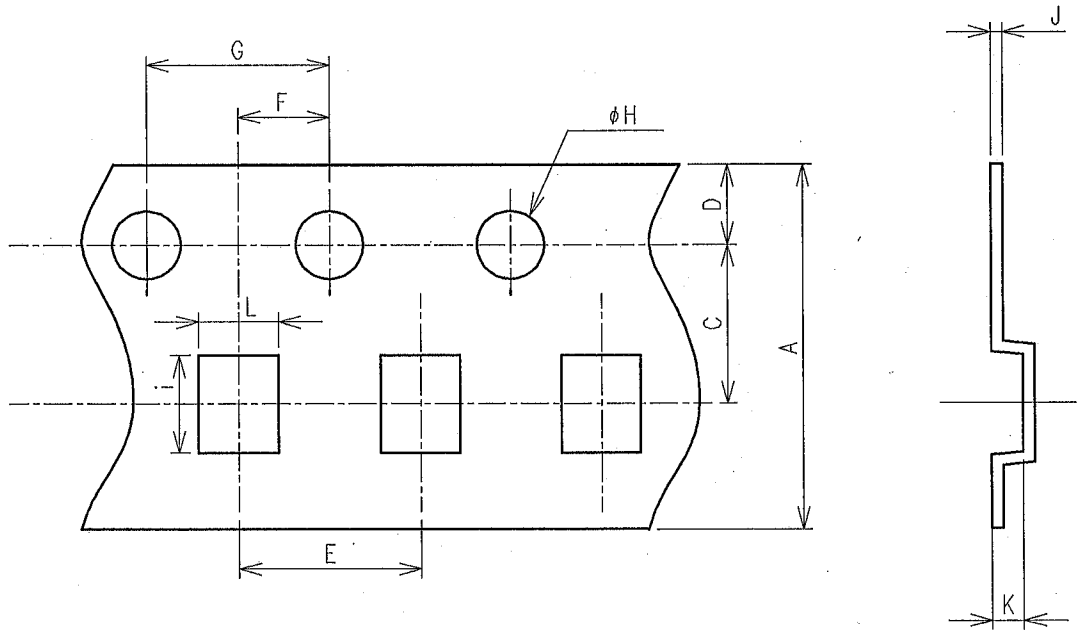

Unit \ Symbol	A	C	D	E	F	G
mm	8.0 ^{±0.1}	3.5 ^{±0.1}	1.75 ^{±0.1}	4.0 ^{±0.1}	2.0 ^{±0.1}	4.0 ^{±0.1}

Unit \ Symbol	H	i	J	K	L
mm	φ 1.5 ^{+0.1/-0}	2.12 ^{±0.1}	0.25 ^{±0.1}	0.70 ^{±0.1}	1.70 ^{±0.1}

Reel structure and Dimensions

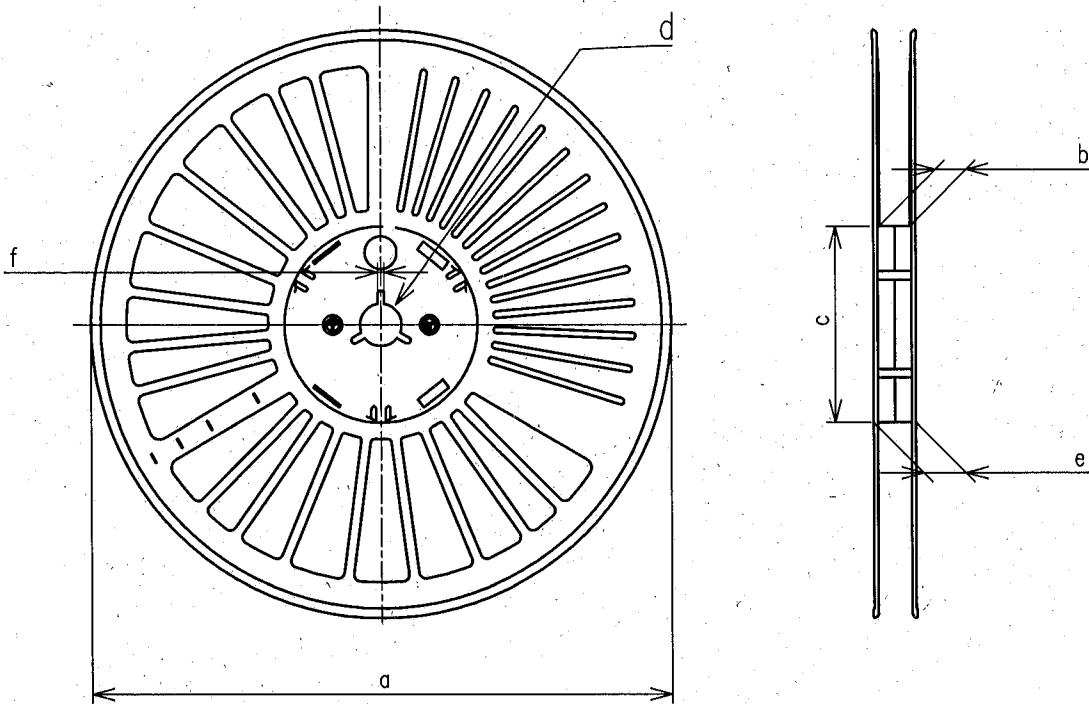

unit	symbol	a	b	c	d	e	f
mm		$180^{\pm 1}$	$9.5^{\pm 1}$	$60^{\pm 1}$	$13^{\pm 0.2}$	$13.1^{\pm 1}$	$2.0^{\pm 0.5}$

Direction of product insertion

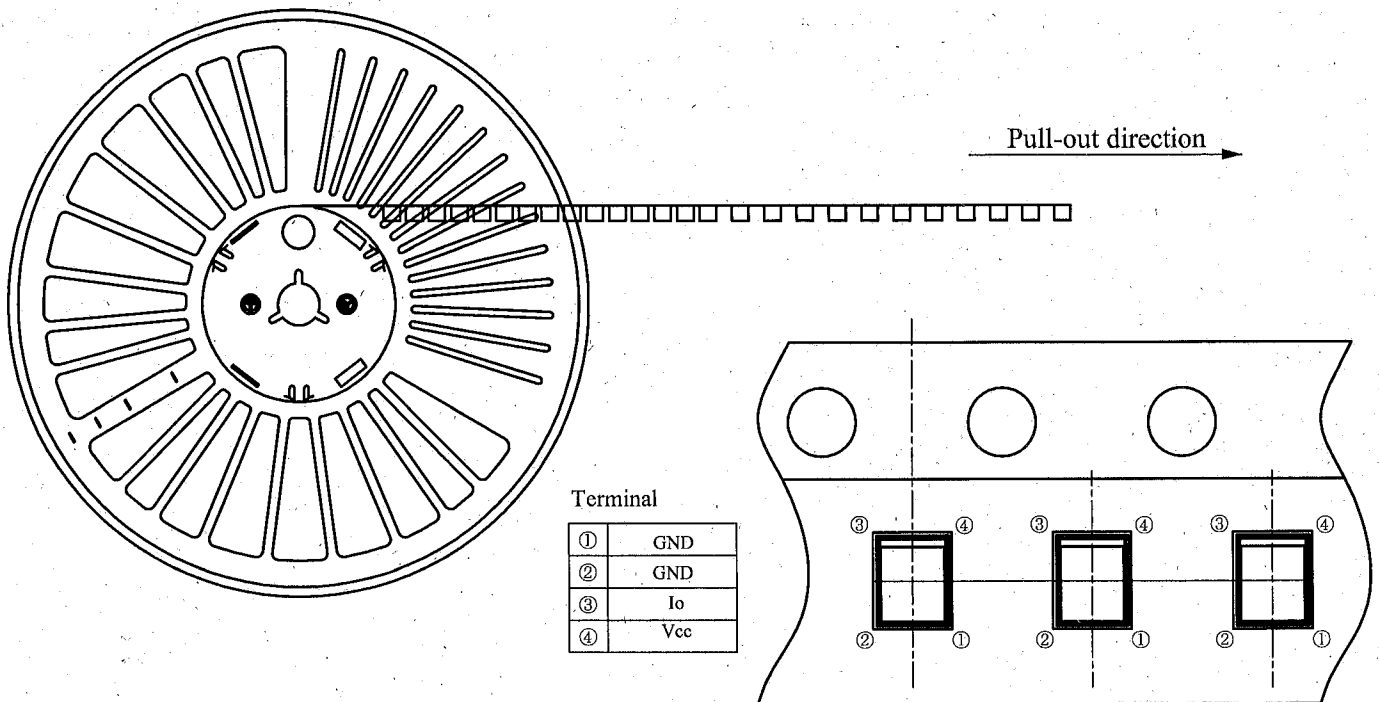

Moisture-proof package specification (φ 180mm reel)

1. Application

This specification applies to the products which Sharp delivers to customer.

2. Packing specifications

2.1 Packaging material

Name	Material	Quantity	Aim
Aluminum laminated bag	Aluminum polyethylene	Refer to 2.2	Moisture-proof
Label	Paper(-made)	-	Indication of Model No. and Quantity
Humidity indicator card	Paper(-made)	1 sheet / reel	Indication of Humidity

2.2 Packaging method

- (1) Seal the aluminum laminated bag included the ruled tape-reel and humidity indicator card quantity.
- (2) Fill up the blank of label and paste on the bag.
- (3) Put the moisture-proof laminated bag in the ruled case

Package shape	Product	Quantity	Moisture-proof sack Quantity
Tape-reel (φ 180mm)	1ch. type	2000pcs. / reel	1 reel / bag

Minimum order Quantity : 1 reel / bag

- (4) Packing case is closed by craft tape and Model No., Quantity, and Inspection date are filled out.
(Quantity: 10,000pcs./case) *Except the case products by failing to seal are cut out.

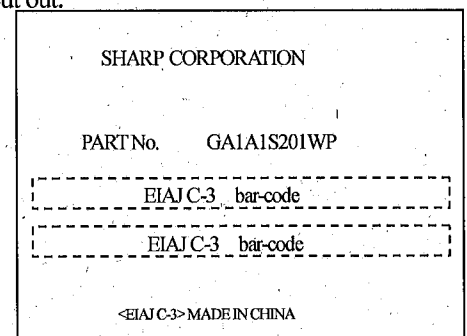

3. Storage and management after opening the package

3.1 Storage condition : Storage shall be in accordance with the below conditions.

Storage temp. : 5 to 30°C

Storage humidity : 70%RH or less

3.2 Treatment after opening the package

- (1) After open, please mount at the conditions of humidity 60%RH or less and temperature 5 to 25°C within 3 days.
- (2) In case of long time storage after open, please mount at the conditions of humidity 70%RH or less and temperature 5 to 30°C within 2 weeks by using dry box or resealing with desiccant in moisture-proof sack by sealer.

3.3 Baking before mounting

In case that it could not carry out the above treatment, it is able to mount by baking treatment. However baking treatment shall be limited only 1 time.

Recommended conditions : 125°C, 16 to 24 hours

Recommended conditions at the packaged condition by the reel : 65°C, 48 hours

- ※ In the case baking at the packaged condition, please hang the reel on the oven using the spindle through the center hall Please do not put the reel across the oven.

Looking for pricing, stock, or lifecycle information?

Click below to explore more details on WIN SOURCE:

- ⊖ [View GA1A1S201WP](#) on WIN SOURCE
- ⊖ [Sharp Microelectronics](#) Information

Optimize Your Supply Chain with WIN SOURCE Solutions

- ✓ Global Sourcing Solution
- ✓ Obsolete Management
- ✓ Cost Control Management
- ✓ Shortage Management
- ✓ Alternative Solution
- ✓ Excess Inventory Management