



**THE DATASHEET OF
G3JA-D416B AC100-240**



Three-Phase Hybrid Soft Starter G3JA

Current Limit Start
for 3-phase, 6-lead Motors

G3JA-D



Soft Start, Kick Start, Current
Limit Start, and Soft Stop

G3JA-C



G3JA Series

G3JA-D

Specifications

Rated operating voltage (motor)	200 to 480 VAC 50/60 Hz
Rated operating current (motor)	3 to 64 A
Applicable motor capacity IEC 60947-4-2, 230 VAC	0.55 to 18.5 kW

Functions

Soft start	No
Kick start	No
Current limit start	Yes
Soft stop	No
Alarm contact output (NO)	Yes
Operating status output (NO)	No
Optional Auxiliary Contact Block output	Yes
Fault detection LED indicator	Yes
Overload protection	Yes
Phase reversal detection	No
Current imbalance detection	Yes
Internal delta control for 3-phase, 6-lead motor	Yes

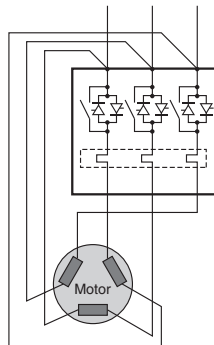
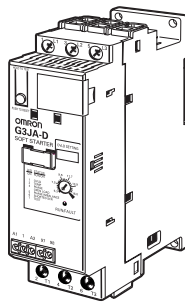

Applicable Motors

The G3JA-D can be used for a 3-phase, 6-wire motor that supports star-delta starting. It is compact and equipped with star-delta starting capabilities, as shown at the right.

G3JA-C

Specifications

Rated operating voltage (motor)	200 to 480 VAC 50/60 Hz
Rated operating current (motor)	3 to 37 A
Applicable motor capacity IEC 60947-4-2, 230 VAC	0.55 to 7.5 kW

Functions

Soft start (See note.)	Yes
Kick start	Yes
Current limit start (See note.)	Yes
Soft stop	Yes
Alarm contact output (NO)	Yes
Operating status output (NO)	Yes
Optional Auxiliary Contact Block output	Yes
Fault detection LED indicator	Yes
Overload protection	Yes
Phase reversal detection	Yes
Current imbalance detection	Yes

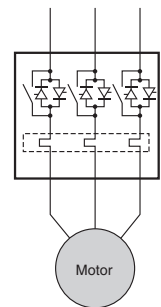
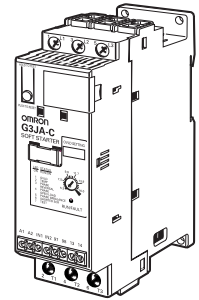

Note: The soft start and current limit start functions cannot be used at the same time.

Applicable Motors

The G3JA-C is connected as shown in the diagram at the right. It can thus be used with a 3-phase, 3-lead motor. (When using a 3-phase, 6-lead/12-lead motor, delta wiring is required in the motor.)

Three-Phase Hybrid Soft Starter (Current Limit Start for 3-phase, 6-lead Motors)

G3JA-D

Built-in Bypass Relay and Smooth Motor Starts Achieved in a Compact Starter

- A current limit start for a 3-phase, 6-lead motor achieves the functionality of a star-delta starter with internal wiring.
- Phase control using a thyristor limits current when the motor starts, and a bypass relay minimizes power loss while the motor is running.
- Built-in electronic thermal overload relay.
- Built-in fault diagnosis for thyristor overtemperature, phase loss/open load, current imbalance, and thyristor short-circuits.
- cULus listed; complies with IEC standards.
- Mounts with screws or to DIN track.
- Built-in operation/fault indicator.
- Built-in auxiliary contact for fault indication.
- An optional Auxiliary Contact Block can be mounted to output operating status.

Note: Refer to *Safety Precautions* on page 25.



Model Number Structure

■ Model Number Legend

Soft Starter

G3JA-D□□□□
1 2 3 4 5

- 1. Controller Type**
D: Current limit start
- 2. Rated Operating Voltage of Main Circuit**
4: 200 to 480 VAC, 3 phase, 50/60 Hz
- 3. Rated Operating Current of Main Circuit**
03: 3 A
09: 9 A
16: 16 A
20: 20 A
25: 25 A
32: 32 A
51: 51 A
64: 64 A
- 4. Terminal Type**
B: Screw terminals (screw clamps)
- 5. Control Voltage**
AC100-240: 100 to 240 VAC 50/60 Hz
AC/DC24: 24 VAC 50/60 Hz, 24 VDC

Accessories

G32J-□□
1 2

- 1. Option**
CA: Auxiliary Contact Block
- 2. Number of Contacts**
10: 1 NO
20: 2 NO
01: 1 NC
11: 1 NO/1 NC

G32J-□
1

- 1. Option**
CF64: Fan
TA10: Round Terminal Block Adapter

Ordering Information

■ List of Models

Soft Starters (Complies with IEC 60947-4-2)

100 to 240-VAC Models

Rated Operating Current of Main Circuit		kW			HP			Model
Current rating (A)	Adjustable range (A)	200 VAC 50/60 Hz	230 VAC 50 Hz	380/400/415 VAC 50 Hz	200 VAC 60 Hz	230 VAC 60 Hz	460 VAC 60 Hz	
3	1 to 3	0.2 to 0.4	0.55	1.1	0.5	0.5	0.5 to 1.5	G3JA-D403B AC100-240
9	3 to 9	0.55 to 1.5	2.2	4	0.75 to 2	0.75 to 2	1.5 to 5	G3JA-D409B AC100-240
16	5.3 to 16	1.1 to 2.2	4	7.5	1.5 to 3	1.5 to 5	5 to 10	G3JA-D416B AC100-240
20	6.7 to 20	1.5 to 3.7	5.5	7.5	2 to 5	2 to 5	5 to 10	G3JA-D420B AC100-240
25	9.2 to 27.7	2.2 to 5.5	5.5	11	3 to 7.5	3 to 7.5	7.5 to 15	G3JA-D425B AC100-240
32	10.9 to 32.9	3.7 to 7.5	7.5	15	3 to 10	5 to 10	7.5 to 20	G3JA-D432B AC100-240
51	17.3 to 51.9	5.5 to 11	15	22	5 to 15	7.5 to 15	15 to 30	G3JA-D451B AC100-240
64	21.3 to 64	5.5 to 15	18.5	30	7.5 to 20	7.5 to 20	20 to 40	G3JA-D464B AC100-240

Note: The applicable motor capacities given in the table are reference values. Select a model so that the full load current of the motor is within the adjustable range of the rated operating current of the main circuit of the G3JA. Only motors that support star-delta starting, such as 3-phase, 6-wire/12-wire motors, can be used.

24-VDC Models

Rated Operating Current of Main Circuit		kW			HP			Model
Current rating (A)	Adjustable range (A)	200 VAC 50/60 Hz	230 VAC 50 Hz	380/400/415 VAC 50 Hz	200 VAC 60 Hz	230 VAC 60 Hz	460 VAC 60 Hz	
3	1 to 3	0.2 to 0.4	0.55	1.1	0.5	0.5	0.5 to 1.5	G3JA-D403B AC/DC24
9	3 to 9	0.55 to 1.5	2.2	4	0.75 to 2	0.75 to 2	1.5 to 5	G3JA-D409B AC/DC24
16	5.3 to 16	1.1 to 2.2	4	7.5	1.5 to 3	1.5 to 5	5 to 10	G3JA-D416B AC/DC24
20	6.7 to 20	1.5 to 3.7	5.5	7.5	2 to 5	2 to 5	5 to 10	G3JA-D420B AC/DC24
25	9.2 to 27.7	2.2 to 5.5	5.5	11	3 to 7.5	3 to 7.5	7.5 to 15	G3JA-D425B AC/DC24
32	10.9 to 32.9	3.7 to 7.5	7.5	15	3 to 10	5 to 10	7.5 to 20	G3JA-D432B AC/DC24
51	17.3 to 51.9	5.5 to 11	15	22	5 to 15	7.5 to 15	15 to 30	G3JA-D451B AC/DC24
64	21.3 to 64	5.5 to 15	18.5	30	7.5 to 20	7.5 to 20	20 to 40	G3JA-D464B AC/DC24

Note: The applicable motor capacities given in the table are reference values. Select a model so that the full load current of the motor is within the adjustable range of the rated operating current of the main circuit of the G3JA. Only motors that support star-delta starting, such as 3-phase, 6-wire/12-wire motors, can be used.

■ Accessories (Order Separately)

Product name	Model	Remarks
Auxiliary Contact Blocks	G32J-CA10	Contact configuration: 1 NO
	G32J-CA20	Contact configuration: 2 NO
	G32J-CA01	Contact configuration: 1 NC
	G32J-CA11	Contact configuration: 1 NO/1 NC
Fan	G32J-CF64	
Round Terminal Block Adapters	G32J-TA10	Set of 2 Adapters

Note: Refer to page 24 for details.

Specifications

■ Ratings and Characteristics

Ratings

Item	Model	G3JA-D403	G3JA-D409	G3JA-D416	G3JA-D420	G3JA-D425	G3JA-D432	G3JA-D451	G3JA-D464
Rated operating current		3 A	9 A	16 A	20 A	25 A	32 A	51 A	64 A
Heat dissipation, continuous		7 W	7 W	7 W	8 W	8 W	10 W	14 W	19 W
Rated operating voltage of main circuit		200 to 480 VAC, 50/60 Hz, 3-phase (±10%)							
Main circuit power supply terminals (L1, L2, and L3)	Wire gauge	2.5 to 25 mm ² (14 to 4 AWG)							
	Tightening torque	2.3 to 3.4 N·m							
Main circuit load power terminals (T1, T2, and T3)	Wire gauge	2.5 to 16 mm ² (14 to 6 AWG)							
	Tightening torque	2.3 to 3.4 N·m							
Control terminals	Wire gauge	0.2 to 2.5 mm ² (24 to 14 AWG)							
	Tightening torque	0.5 to 0.9 N·m							
Rated operating current		3 A	9 A	16 A	20 A	25 A	32 A	51 A	64 A
Maximum delta current		1.74 A	5.2 A	9.3 A	11.6 A	14.5 A	17.4 A	29.6 A	36.5 A
Overload current range		1 to 3 A	3 to 9 A	5.3 to 16 A	6.7 to 20 A	9.2 to 27.7 A	10.9 to 32.9 A	17.3 to 51.9 A	21.3 to 64 A
Control voltage		100 to 240 VAC or 24 VAC, 50/60 Hz, 24 VDC							

Short Circuit Coordination (Maximum Fuse or Circuit Breaker Size) Type 1

Item	Model	G3JA-D403	G3JA-D409	G3JA-D416	G3JA-D420	G3JA-D425	G3JA-D432	G3JA-D451	G3JA-D464	
UL Class K5 and RK5 fuses UL listing (600 V)		Rated breaking current: 5 kA						Rated breaking current: 10 kA		
		10 A	35 A	60 A	80 A	100 A	125 A	200 A	250 A	
UL-listed thermal electromagnetic circuit breaker UL listing (600 V)		Rated breaking current: 5 kA						Rated breaking current: 10 kA		
		15 A	35 A	60 A	80 A	100 A	125 A	200 A	250 A	

Main Circuit

Item	Classification	cULus (UL 508)	IEC (EN/IEC 60947-4-2)
Rated operating voltage		200 to 480 VAC	400 VAC
Isolation rated voltage		600 VAC	500 VAC
Dielectric strength (between control and main circuits)		2,200 VAC	2,500 VAC
Repetitive peak voltage		1,400 V	1,400 V
Operating frequency		50/60 Hz	
Utilization category		Intermittent duty	AC-53b
Single-phase/3-phase		Equipment designed for 3-phase only	
Rated impulse voltage		6 kV	
DV/DT protection		1,000 V/μs	
Overvoltage category		III	

Environmental Conditions

Item	Classification	cULus (UL 508)	IEC (EN/IEC 60947-4-2)
Ambient operating temperature		0 to 50°C	
Ambient storage temperature		-25 to 85°C	
Elevation		2,000 m max.	
Humidity		5% to 85% (with no condensation)	
Pollution degree		2	
Degree of protection		IP20	

Control Circuit

Item	Classification	cULus (UL 508)	IEC (EN/IEC 60947-4-2)
Rated operational voltage		100 to 240 VAC 50/60 Hz, 24 VAC 50/60 Hz, 24 VDC	
Voltage range		±10% of control voltage	
Overvoltage category		---	III (See note.)
Input onstate voltage minimum during start (A1, A2)		90 VAC max. (100 to 240 VAC), 15.2 VAC/21.6 VDC max. (24 VAC/DC)	
Input offstate voltage maximum (A1, A2)		30 VAC min. (100 to 240 VAC), 12 VAC/17 VDC min. (24 VAC/DC)	
Offstate current consumption		2 mA max.	
Onstate current consumption, with Fan (A2)		195 mA max. at 120 VAC/140 mA max. at 240 VAC, 650 mA max. at 24 VAC/790 mA max. at 24 VDC	
Onstate current consumption, without Fan (A2)		185 mA max. at 120 VAC/125 mA max. at 240 VAC, 570 mA max. at 24 VAC/695 mA max. at 24 VDC	

Note: Overvoltage category II applies when control or auxiliary contacts are connected to an SELV or PELV circuit.

Auxiliary Contacts

Item	Classification	cULus (UL 508)	IEC (EN/IEC 60947-4-2)
Rated operational voltage		250 VAC/30 VDC	250 VAC/30 VDC
Rated impulse voltage		---	4 kV
Dielectric strength		1,500 VAC	2,000 VAC
Overvoltage category		---	III (See note.)
Operating frequency		50/60 Hz	
Utilization category		D300	AC15
TB-97, -98 (overload/fault)	Control circuit configuration	Electromagnetic relay	
	Number of contacts	1	
	Contact	NO contact	
	Current specifications	AC/DC	
	Rated operating current	0.6 A at 120 VAC, 0.3 A at 240 VAC	
	Contact switching capacity	Open: 72 VA Close: 432 VA	

Note: Overvoltage category II applies when control or auxiliary contacts are connected to an SELV or PELV circuit.

Standard Functions

Item	Classification	cULus (UL 508)	IEC (EN/IEC 60947-4-2)
Start time		2 s, 5 s, 10 s, or 15 s	
Current limit		150%, 250%, 300%, or 350% of full-load current	
Weight		Approx. 860 g	

Vibration and Shock Resistance

Item	Classification	cULus (UL 508)	IEC (EN/IEC 60947-4-2)
Vibration resistance	Destruction	25-m/s ² peak, 10 to 55 to 10 Hz, 0.19-mm single amplitude	
	Malfunction	10-m/s ² peak, 10 to 55 to 10 Hz, 0.075-mm single amplitude	
Shock resistance	Destruction	300 m/s ² (30 G)	
	Malfunction	150 m/s ² (15 G)	

Other Specifications

Item	Classification	cULus (UL 508)	IEC (EN/IEC 60947-4-2)
EMI (emission test)	Noise terminal voltage	---	Class A
	Radiation field	---	Class A
EMS (immunity test)	Electrostatic discharge	4 kV contact discharge and 8 kV air discharge	
	Radio frequency electromagnetic field	---	Conforms to IEC 60947-4-2
	Electrical fast transient	---	Conforms to IEC 60947-4-2
	Surge immunity	---	Conforms to IEC 60947-4-2

■ Applicable Standards

Safety standards	UL 508 (Listing: File No. E96956), CSA 22.2 No. 14, EN/IEC 60947-4-2
EMC Directives	Emissions: EN 55011 Group 1 Class A Immunity: EN 61000-4

Connections

Wiring

Two-wire Connections

IEC

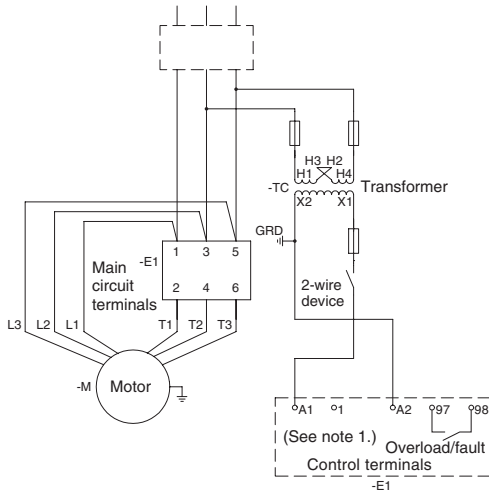

NEMA

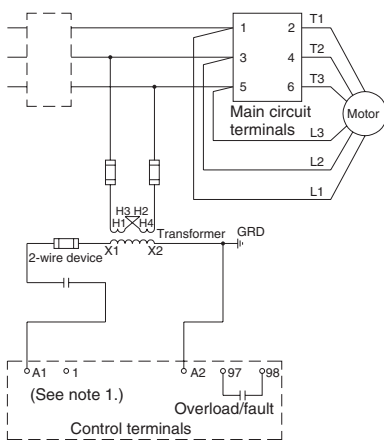

Operation Chart: Two-wire Connections with Forward/Reverse Rotation

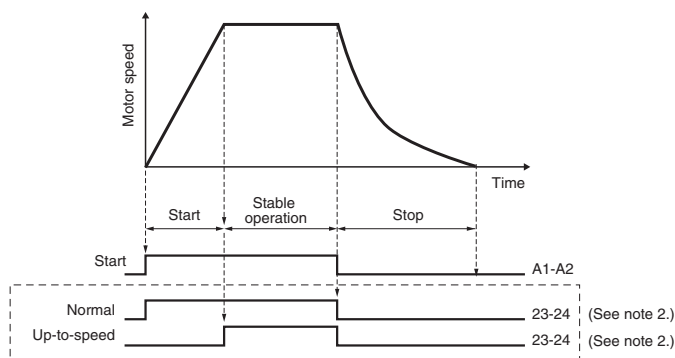

- Note:** 1. Always keep terminal 1 open.
2. Operation of the Auxiliary Contact Block.

Three-wire Connections

IEC

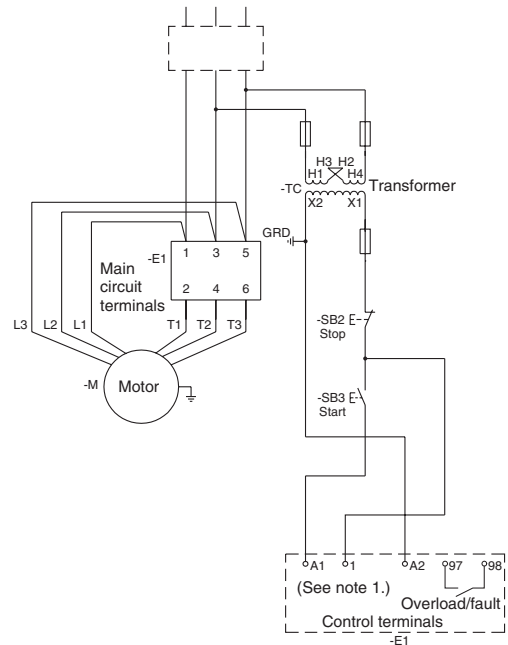

NEMA

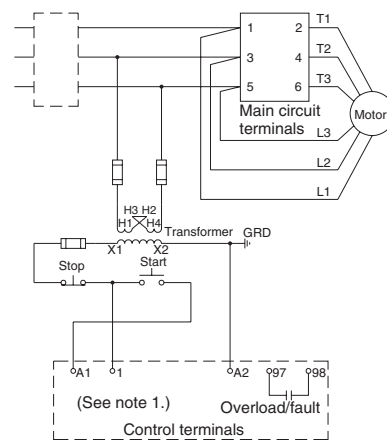

Operation Chart: Three-wire Connections with Main Circuit Fault Shutoff

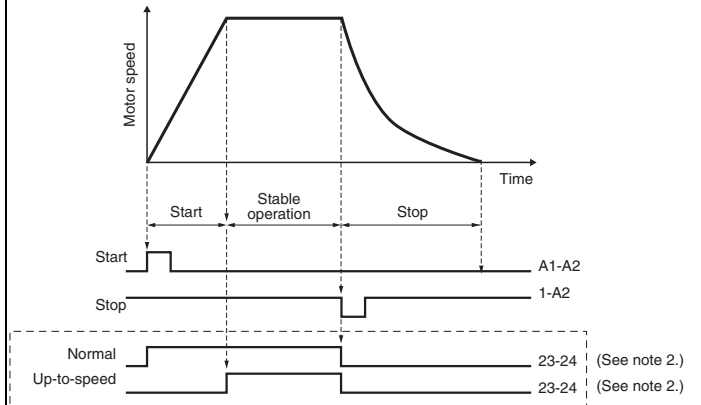

Examples: Main Circuit Fault Shutoff

IEC

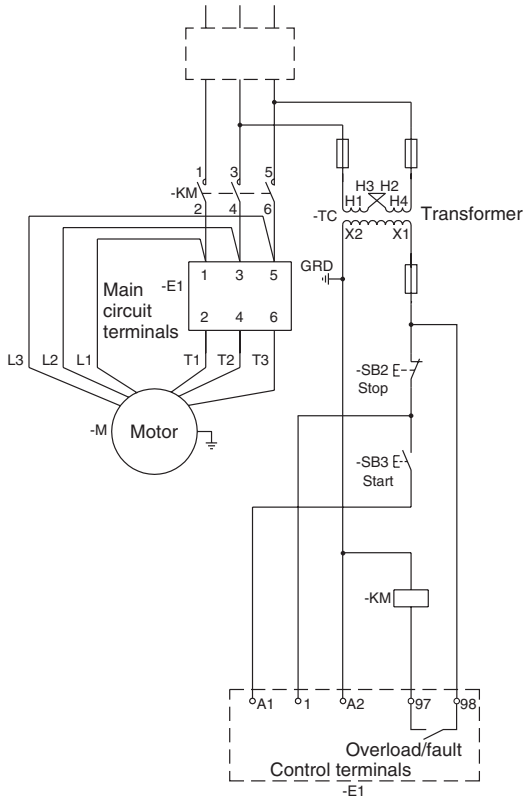

NEMA

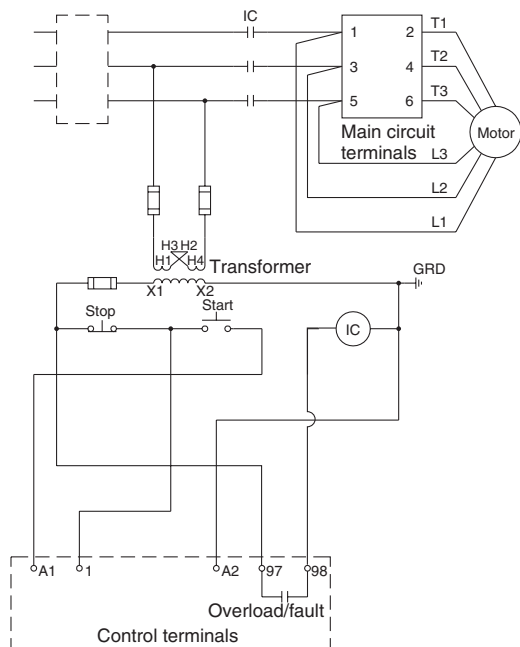

Note: Operation chart is same as for *Three-wire Connections*.

Forward/Reverse Rotation

Note: Provide a time lag of at least 1.0 s between forward and reverse rotation.

IEC

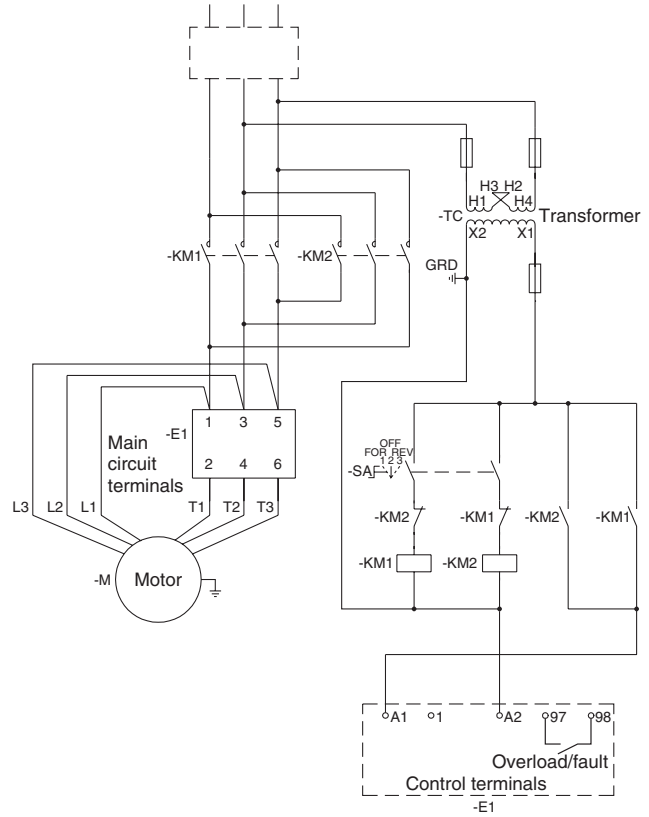

NEMA

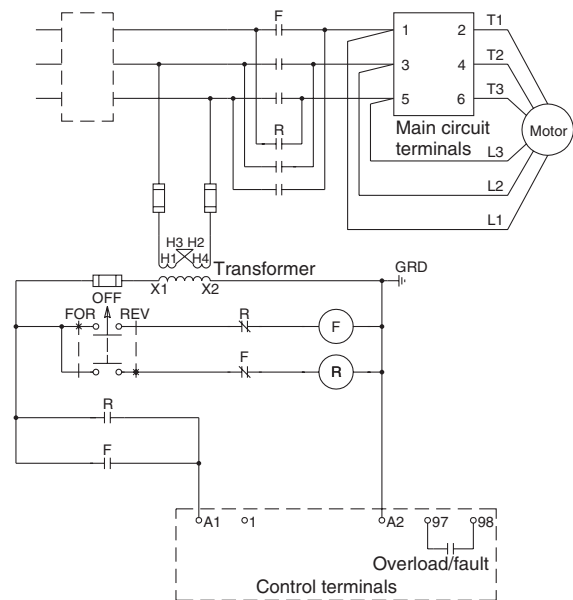

Note: Operation Chart is same as for *Two-wire Connections*.

Operation

■ Operating Modes

Current Limit Start

This start mode is used when the maximum current must be limited at startup. During the start time, the thyristor will reduce the motor terminal voltage to limit the current at startup. During stable operation, the built-in bypass relay will be ON.

The current limit can be set to 150%, 250%, 300%, or 350% of the full-load current. The start time can be set to 2 s, 5 s, 10 s, or 15 s.

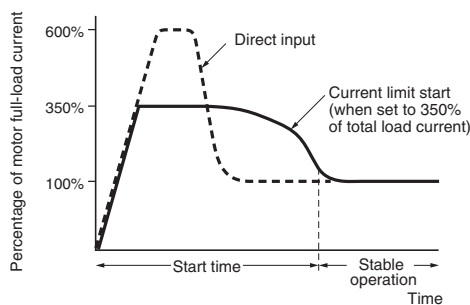

Start Time for a Current Limit Start

A built-in current transformer (CT) is used to detect the motor current. The completion of motor startup is determined by detecting the convergence of the current as the speed of the motor increases. The soft starter operation is then changed to stable operation. The start time given here is a guideline for when the total load current set on the overload FLA setting dial and the actual load current are the same. If the motor load is smaller, the motor will start faster, so that actual start time will be shorter than the start time given here.

■ Description of Functions

Overload Protection

The G3JA-D is equipped with overload protection. The overload class can be set to OFF, 10, 15, or 20. Either automatic or manual mode can be used to reset an overload (trip). Set the trip current to the rated full-load current of the motor through the overload FLA setting dial. When an overload fault occurs, the G3JA-D indicates the overload with a flashing LED indicator and closes the alarm contact.

Overtemperature

The G3JA-D monitors SCR temperature through an internal thermistor. If the SCR gets too hot, the G3JA-D turns OFF the output, indicates the overtemperature status with a flashing LED indicator and closes the alarm contact.

Phase Loss

The G3JA-D monitors phase loss. If phase loss lasts for two power supply frequency cycles, the G3JA-D turns OFF the output, indicates the phase loss with a flashing LED indicator and closes the alarm contact.

Current Imbalance

The G3JA-D monitors the phase current imbalance. If the imbalance exceeds the preset limit, the G3JA-D turns OFF the output, indicates the current imbalance with a flashing LED indicator and closes the alarm contact.

Shorted SCR

The G3JA-D always checks the SCR for a short circuit before the starting sequence. If a short circuit is found, the G3JA-D stops the starting sequence, indicates the short circuit with a flashing LED indicator and closes the alarm contact.

Nomenclature

Part Names and Functions

Main Circuit Terminals, Power Supply Side

Reset Button
All faults can be reset by pressing the Reset Button or turning OFF the control power supply. Cooling time may be required before overload and overtemperature can be reset.
Note: Test Mode for overload testing will be entered when the Reset Button is pressed for at least 1 second. Test Mode will be canceled when the Reset Button is pressed again.

DIP Switch Configuration
Use the DIP switch to set the functions.

DIP switch pin No.	Function
1	Start time
2	
3	Current limit start setting
4	
5	Overload class selection
6	
7	Overload reset
8	Optional auxiliary relay #1 (Normal/Up-to-speed)

Overload FLA Setting Dial
Use this dial to set the trip current to the rated full-load current of the motor.

RUN/FAULT Indicator
The G3JA-D uses one indicator to indicate both normal operation (RUN) and faults (FAULT). If the G3JA-D detects a fault, it turns OFF the motor and indicates the fault with a flashing LED indicator. The G3JA-D monitors the following conditions.

Fault	Flashing indicator status
Overload	[Pulse]
Over-temperature	[Pulse]
Phase loss	[Pulse]
Current imbalance	[Pulse]
Shorted SCR	[Pulse]

Control Terminals
The G3JA-D has five input terminals on the front. Each terminal is described in the following table.

Terminal	Description
A1	Control power supply/START input
1	STOP input
A2	Control power supply common
97	NO auxiliary contact (auxiliary contact for fault detection output)
98	NO auxiliary contact (auxiliary contact for fault detection output)

Main Circuit Terminals, Load Side

Auxiliary Contacts
The G3JA-D is equipped with one auxiliary contact as a standard feature. It is used for fault detection output. An optional Auxiliary Contact Block can be added, and DIP switch pin number 8 can be used to set the operating status to output (either *Normal* or *Up-to-speed*).

■ DIP Switch Settings

Start Time

DIP switch pin No.		Time (seconds)
1	2	
OFF	OFF	2
ON	OFF	5
OFF	ON	10
ON	ON	15

Current Limit Start

DIP switch pin No.		Current limit setting
3	4	
OFF	OFF	150%
ON	OFF	250%
OFF	ON	300%
ON	ON	350%

Overload Class Selection

DIP switch pin No.		Overload class
5	6	
OFF	OFF	OFF
ON	OFF	10
OFF	ON	15
ON	ON	20

Overload Reset

DIP switch pin No.: 7	Reset
ON	Automatic
OFF	Manual

Optional Auxiliary Relay #1

DIP switch pin No.: 8	Setting
ON	Up-to-speed
OFF	Normal

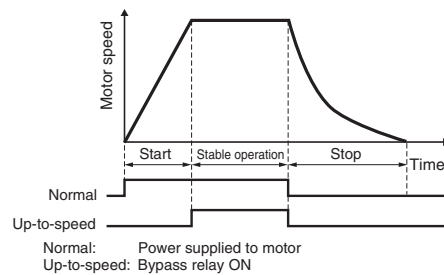

Three-Phase Hybrid Soft Starter (Soft Start, Kick Start, Current Limit Start, Soft Stop)

G3JA-C

Built-in Bypass Relay and Smooth Motor Starts/Stops Achieved in a Compact Starter

- Advanced functions include soft start, kick start, and soft stop.
- Phase control using a thyristor limits current when the motor starts, and a bypass relay minimizes power loss while the motor is running.
- Controls a 3-phase, 3-lead motor.
- Built-in electronic thermal overload relay.
- Built-in fault diagnosis for overtemperature, phase reversal, phase loss/open load, current imbalance, and shorted SCR.
- cULus listed; complies with IEC standards.
- Mounts with screws or to DIN track.
- Built-in operation/fault indicator.
- Built-in auxiliary contact for fault indication.
- Built-in auxiliary contact to output operating status.
- An Optional Auxiliary Contact Block can be added to output operating status.

Note: Refer to *Safety Precautions* on page 25.



Model Number Structure

■ Model Number Legend

Soft Starter

G3JA-C□□□□□
1 2 3 4 5

- 1. Controller Type**
C: Soft start/stop
- 2. Rated Operating Voltage of Main Circuit**
4: 200 to 480 VAC, 3 phase, 50/60 Hz
- 3. Rated Operating Current of Main Circuit**
03: 3 A
09: 9 A
16: 16 A
19: 19 A
25: 25 A
30: 30 A
37: 37 A
- 4. Terminal Type**
B: Screw terminals (screw clamps)
- 5. Control Voltage**
AC100-240: 100 to 240 VAC 50/60 Hz
AC/DC24: 24 VAC 50/60 Hz, 24 VDC

Accessories

G32J-□□
1 2

- 1. Option**
CA: Auxiliary Contact Block
- 2. Number of Contacts**
10: 1 NO
20: 2 NO
01: 1 NC
11: 1 NO/1 NC

G32J-□
1

- 1. Option**
CF64: Fan
TA10: Round Terminal Block Adapter

Ordering Information

■ List of Models

Soft Starters (Complies with IEC 60947-4-2)

100 to 240-VAC Models

Rated Operating Current of Main Circuit		kW					HP						Model
		200 VAC 50/60 Hz	230 VAC 50 Hz	380/400/415 VAC 50 Hz		200 VAC 60 Hz	230 VAC 60 Hz	460 VAC 60 Hz					
Current rating (A)	Adjustable range (A)	Starting load											
		350%	350%	450%	350%	450%	350%	450%	350%	450%	350%	450%	
3	1 to 3	0.2 to 0.4	0.55	0.37	1.1	0.75	0.5	0.5	0.5	0.5	0.5 to 1.5	0.5 to 1	G3JA-C403B AC100-240
9	3 to 9	0.55 to 1.5	2.2	1.5	4	3	0.75 to 2	0.75 to 1.5	0.75 to 2	0.75 to 2	1.5 to 5	1.5 to 3	G3JA-C409B AC100-240
16	5.3 to 16	1.1 to 2.2	4	3	7.5	5.5	1.5 to 3	1.5 to 3	1.5 to 5	1.5 to 3	5 to 10	5 to 7.5	G3JA-C416B AC100-240
19	6.3 to 19	1.5 to 3.7	4	4	7.5	5.5	1.5 to 5	1.5 to 3	2 to 5	2 to 3	5 to 10	5 to 10	G3JA-C419B AC100-240
25	8.3 to 25	2.2 to 5.5	5.5	4	11	9.5	3 to 7.5	3 to 5	3 to 7.5	3 to 5	7.5 to 15	7.5 to 10	G3JA-C425B AC100-240
30	10 to 30	2.2 to 5.5	7.5	5.5	15	11	3 to 7.5	3 to 5	5 to 10	5 to 7.5	7.5 to 20	7.5 to 15	G3JA-C430B AC100-240
37	12.3 to 37	3.7 to 7.5	7.5	7.5	18.5	15	5 to 10	5 to 7.5	5 to 10	5 to 10	10 to 25	10 to 20	G3JA-C437B AC100-240

Note: The applicable motor capacities given in the table are reference values. The motor FLA must fall within the current range of the device.

24-VDC Models

Rated Operating Current of Main Circuit		kW					HP						Model
		200 VAC 50/60 Hz	230 VAC 50 Hz	380/400/415 VAC 50 Hz		200 VAC 60 Hz	230 VAC 60 Hz	460 VAC 60 Hz					
Current rating (A)	Adjustable range (A)	Starting load											
		350%	350%	450%	350%	450%	350%	450%	350%	450%	350%	450%	
3	1 to 3	0.2 to 0.4	0.55	0.37	1.1	0.75	0.5	0.5	0.5	0.5	0.5 to 1.5	0.5 to 1	G3JA-C403B AC/DC24
9	3 to 9	0.55 to 1.5	2.2	1.5	4	3	0.75 to 2	0.75 to 1.5	0.75 to 2	0.75 to 2	1.5 to 5	1.5 to 3	G3JA-C409B AC/DC24
16	5.3 to 16	1.1 to 2.2	4	3	7.5	5.5	1.5 to 3	1.5 to 3	1.5 to 5	1.5 to 3	5 to 10	5 to 7.5	G3JA-C416B AC/DC24
19	6.3 to 19	1.5 to 3.7	4	4	7.5	5.5	1.5 to 5	1.5 to 3	2 to 5	2 to 3	5 to 10	5 to 10	G3JA-C419B AC/DC24
25	8.3 to 25	2.2 to 5.5	5.5	4	11	9.5	3 to 7.5	3 to 5	3 to 7.5	3 to 5	7.5 to 15	7.5 to 10	G3JA-C425B AC/DC24
30	10 to 30	2.2 to 5.5	7.5	5.5	15	11	3 to 7.5	3 to 5	5 to 10	5 to 7.5	7.5 to 20	7.5 to 15	G3JA-C430B AC/DC24
37	12.3 to 37	3.7 to 7.5	7.5	7.5	18.5	15	5 to 10	5 to 7.5	5 to 10	5 to 10	10 to 25	10 to 20	G3JA-C437B AC/DC24

Note: The applicable motor capacities given in the table are reference values. The motor FLA must fall within the current range of the device.

■ Accessories (Order Separately)

Product name	Model	Remarks
Auxiliary Contact Blocks	G32J-CA10	Contact configuration: 1 NO
	G32J-CA20	Contact configuration: 2 NO
	G32J-CA01	Contact configuration: 1 NC
	G32J-CA11	Contact configuration: 1 NO/1 NC
Fan	G32J-CF64	
Round Terminal Block Adapters	G32J-TA10	Set of 2 Adapters

Note: Refer to page 24 for details.

Specifications

■ Ratings and Characteristics

Ratings

Item	Model	G3JA-C403	G3JA-C409	G3JA-C416	G3JA-C419	G3JA-C425	G3JA-C430	G3JA-C437
Rated operating current		3 A	9 A	16 A	19 A	25 A	30 A	37 A
Heat dissipation, continuous		11 W	12 W	14 W	15 W	17 W	19 W	24 W
Rated operating voltage of main circuit		200 to 480 VAC, 50/60 Hz, 3-phase (±10%)						
Main circuit power supply terminals (L1, L2, and L3)	Wire gauge	2.5 to 25 mm ² (14 to 4 AWG)						
	Tightening torque	2.3 to 3.4 N·m						
Main circuit load power terminals (T1, T2, and T3)	Wire gauge	2.5 to 16 mm ² (14 to 6 AWG)						
	Tightening torque	2.3 to 3.4 N·m						
Control terminals	Wire gauge	0.2 to 2.5 mm ² (24 to 14 AWG)						
	Tightening torque	0.5 to 0.9 N·m						
Rated operating current		3 A	9 A	16 A	19 A	25 A	30 A	37 A
Overload current range		1 to 3 A	3 to 9 A	5.3 to 16 A	6.3 to 19 A	8.3 to 25 A	10 to 30 A	12.3 to 37 A
Control voltage		100 to 240 VAC or 24 VAC, 50/60 Hz, 24 VDC						

Short Circuit Coordination (Maximum Fuse or Circuit Breaker Size) Type 1

Item	Model	G3JA-C403	G3JA-C409	G3JA-C416	G3JA-C419	G3JA-C425	G3JA-C430	G3JA-C437
UL Class K5 and RK5 fuse		Rated breaking current: 5 kA						
UL-listed combination (600 V)		10 A	35 A	60 A	70 A	100 A	110 A	125 A
UL-listed thermal electromagnetic circuit breaker		Rated breaking current: 5 kA						
UL-listed combination (600 V)		15 A	35 A	60 A	70 A	100 A	110 A	125 A

Main Circuit

Item	Classification	cULus (UL 508)	IEC (EN/IEC 60947-4-2)
Rated operating voltage		200 to 480 VAC	400 VAC
Isolation rated voltage		600 VAC	500 VAC
Dielectric strength (between the control and main circuits)		2,200 VAC	2,500 VAC
Repetitive peak voltage		1,400 V	1,400 VAC
Operating frequency		50/60 Hz	
Utilization category		Intermittent duty	AC-53b
Single-phase/3-phase		Equipment designed for 3-phase only	
Rated impulse voltage		6 kV	
DV/DT protection		1,000 V/μs	
Overvoltage category		III	

Control Circuits

Item	Classification	cULus (UL 508)	IEC (EN/IEC 60947-4-2)
Rated operational voltage		100 to 240 VAC 50/60 Hz, 24 VAC 50/60 Hz, 24 VDC	
Voltage range		±10% of control voltage	
Overvoltage category		---	III (See note.)
Input onstate voltage minimum during start (A1, A2)		90 VAC max. (100 to 240 VAC), 15.2 VAC/21.6 VDC max. (24 VAC/DC)	
Input onstate current, during start with Fan (IN1, IN2)		9.8 mA at 120 VAC; 19.6 mA at 240 VAC, 7.3 mA at 24 VAC/DC	
Input offstate voltage maximum (A1, A2)		40 VAC min. (100 to 240 VAC), 12 VAC/17 VDC min. (24 VAC/VDC)	
Offstate current consumption (IN1, IN2)		10 mA max. (IN1), 120 mA max. (IN2)	
Onstate current consumption, with Fan (A2)		215 mA max. at 120 VAC/180 mA max. at 240 VAC, 660 mA max. at 24 VAC/800 mA max. at 24 VDC	
Onstate current consumption, without Fan (A2)		205 mA max. at 120 VAC/145 mA max. at 240 VAC, 580 mA max. at 24 VAC/705 mA max. at 24 VDC	

Note: Overvoltage category II applies when control or auxiliary contacts are connected to an SELV or PELV circuit.

Auxiliary Contacts

Item	Classification	cULus (UL 508)	IEC (EN/IEC 60947-4-2)
Rated operational voltage		250 VAC/30 VDC	250 VAC/30 VDC
Rated impulse voltage		---	4 kV
Dielectric strength		1,500 VAC	2,000 VAC
Overvoltage category		---	III (See note.)
Operating frequency		50/60 Hz	
Utilization category		D300	AC15
TB-97, -98 (overload/fault)	Control circuit configuration	Electromagnetic relay	
	Number of contacts	1	
	Contact	NO contact	
	Current specifications	AC/DC	
	Rated operating current	0.6 A at 120 VAC, 0.3 A at 240 VAC	
TB-13, -14 (normal/up-to-speed)	Control circuit configuration	Electromagnetic relay	
	Number of contacts	1	
	Contact	NO contact	
	Current specifications	AC/DC	
	Rated operating current	0.6 A at 120 VAC, 0.3 A at 240 VAC	
	Contact switching capacity	Open: 72 VA Close: 432 VA	
	Contact switching capacity	Open: 72 VA Close: 432 VA	

Note: Overvoltage category II applies when control or auxiliary contacts are connected to an SELV or PELV circuit.

Standard Functions

Item	Classification	cULus (UL 508)	IEC (EN/IEC 60947-4-2)
Start time		2 s, 5 s, 10 s, or 15 s	
Soft start (initial torque)		15%, 25%, 35%, or 65% of locked rotor torque	
Current limit		150%, 250%, 350%, or 450% of full-load current	
Soft stop time		0%, 100%, 200%, or 300% of the start time	
Weight		Approx. 860 g	

Vibration and Shock Resistance

Item	Classification	cULus (UL 508)	IEC (EN/IEC 60947-4-2)
Vibration resistance	Destruction	25-m/s ² peak, 10 to 55 to 10 Hz, 0.19-mm single amplitude	
	Malfunction	10-m/s ² peak, 10 to 55 to 10 Hz, 0.075-mm single amplitude	
Shock resistance	Destruction	300 m/s ² (30 G)	
	Malfunction	150 m/s ² (15 G)	

Environmental Conditions

Item	Classification	cULus (UL 508)	IEC (EN/IEC 60947-4-2)
Ambient operating temperature		0 to 50°C	
Ambient storage temperature		-25 to 85°C	
Elevation		2,000 m max.	
Ambient operating humidity		5% to 85% (with no condensation)	
Pollution degree		2	
Degree of protection		IP20	

Other Specifications

Item	Classification	cULus (UL 508)	IEC (EN/IEC 60947-4-2)
EMI (emission test)	Noise terminal voltage	---	Class A
	Radiation field	---	Class A
EMS (immunity test)	Electrostatic discharge	4 kV contact discharge and 8 kV air discharge	
	Radio frequency electromagnetic field	---	Conforms to IEC 60947-4-2
	Electrical fast transient	---	Conforms to IEC 60947-4-2
	Surge immunity	---	Conforms to IEC 60947-4-2

■ Applicable Standards

Safety standards	UL 508 (Listing: File No. E96956), CSA 22.2 No. 14, EN/IEC 60947-4-2
EMC Directives	Emissions: EN 55011 Group 1 Class A Immunity: EN 61000-4

Examples: Main Circuit Fault Shutoff

IEC

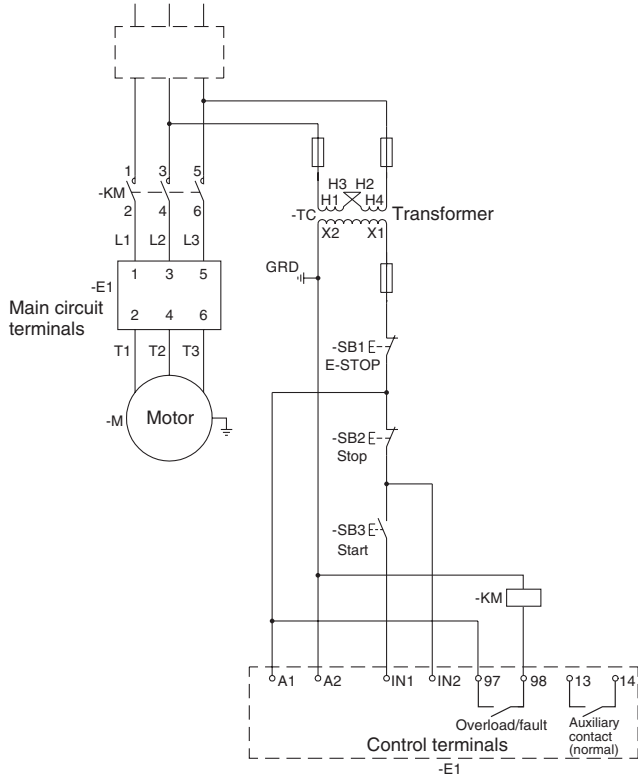

NEMA

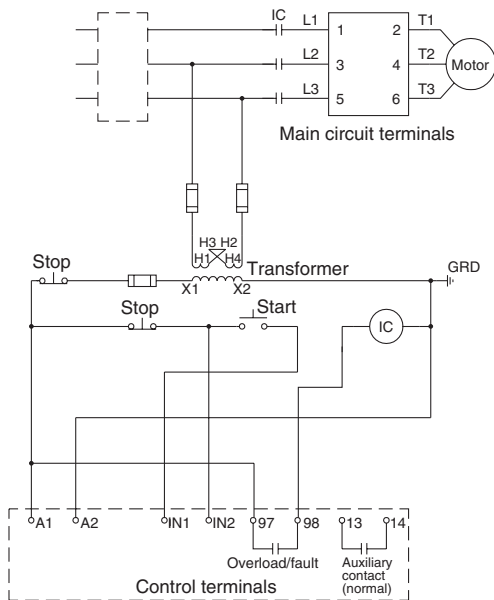

Note: Operation chart is same as for *Three-wire Connections*.

Forward/Reverse Rotation

- Note:** 1. Provide a time lag of at least 1.0 s between forward and reverse rotation.
- 2. Disable phase reversal protection.

IEC

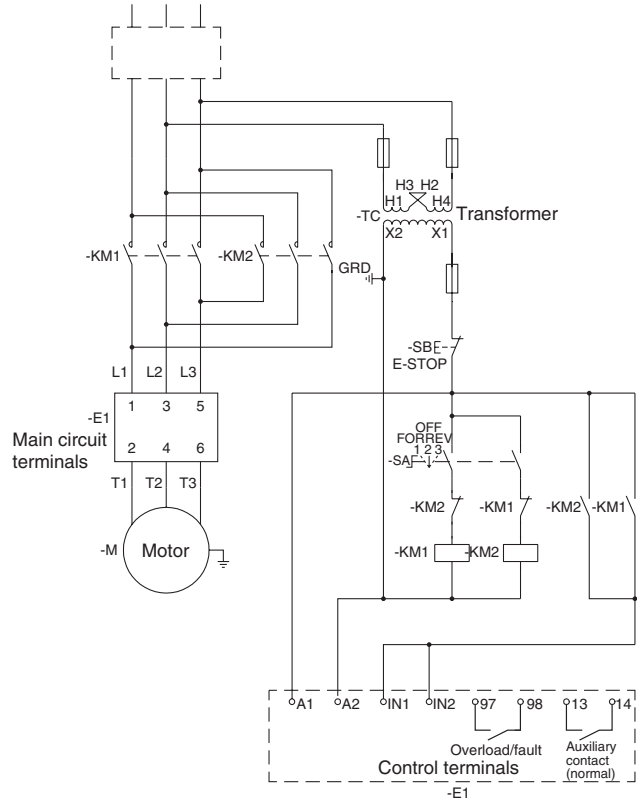

NEMA

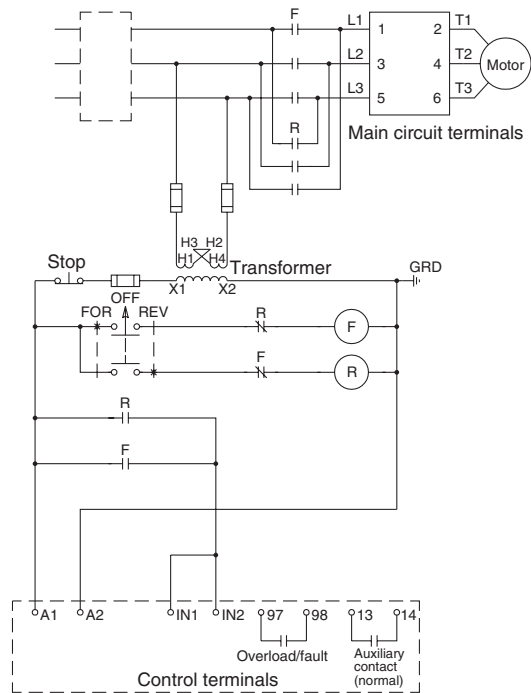

Note: Operation chart is same as for *Two-wire Connections*.

Operation

■ Operating Modes

Soft Start

A soft start is used to reduce mechanical shock when starting the motor. The motor voltage is increased from the initial torque to full voltage.

The initial torque can be set to 15%, 25%, 35%, or 65% of the locked rotor torque. The motor voltage is gradually increased during the acceleration ramp time. The acceleration ramp time can be set to 2 s, 5 s, 10 s, or 15 s.

The bypass relay turns ON after the motor starts.

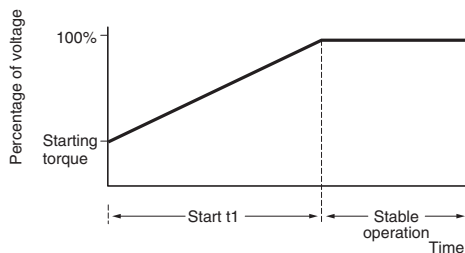

Kick Start

A kick start, or boost, at the beginning of the start mode provides a current pulse of 450% of the full-load current. The kick start time can be set to OFF, 0.5 s, 1 s, or 1.5 s. This allows the motor to develop additional torque at start for loads which may need a boost to get started.

Some loads that may not start well in soft start mode will start more smoothly if the kick start is enabled to provide more rotational torque to the motor. Increase the kick start time one step at a time to gradually increase the initial torque.

The current will increase temporarily during the kick start, but the start mode that was selected will continue after the kick start has been completed.

When the current limit start function has been enabled, the kick start will be disabled.

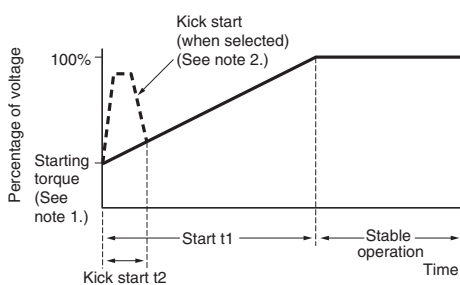

Note: Refer to *DIP Switch Settings* on page 22 for details.

1. Initial Torque Setting for Soft Start
2. Kick Start

Current Limit Start

This start mode is used when the maximum starting current must be limited. During the start time, the thyristor will reduce the motor terminal voltage to limit the current at startup. During stable operation, the built-in bypass relay will be ON.

The current limit can be set to 150%, 250%, 350%, or 450% of the full-load current. The start time can be set to 2 s, 5 s, 10 s, or 15 s.

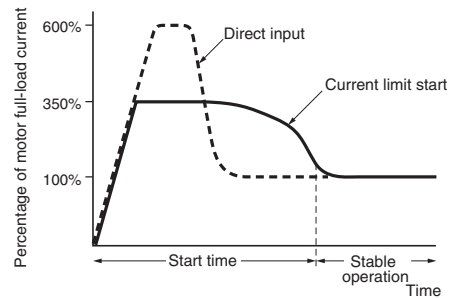

Start Time for a Soft Start or Current Limit Start

A built-in current transformer (CT) is used to detect the motor current. The completion of motor startup is determined by detecting the convergence of the current as the speed of the motor increases. The soft starter operation is then changed to stable operation. The start time given here is a guideline for when the total load current set on the overload FLA setting dial and the actual load current are the same. If the motor load is smaller, the motor will start faster, so that actual start time will be shorter than the start time given here.

Soft Stop

A soft stop is used with applications that require an extended coast to stop. When enabled, the voltage ramp down time can be set to one, two, or three times the start time. The motor will stop when the motor voltage drops to the point where the load torque is greater than the motor torque.

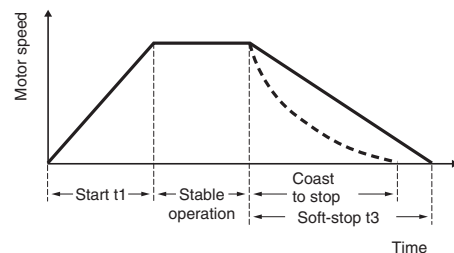

Soft Stop Time

The soft stop function gradually reduces the motor voltage to prevent the motor from stopping suddenly under a large load. A built-in CT is used to detect the motor current and size of the current is used to determine the size of the load and the rate at which the voltage is reduced. If the motor load is extremely small, the soft stop time will be very short.

■ Description of Functions

Overload Protection

The G3JA-C is equipped with overload protection. The overload class can be set to OFF, 10, 15, or 20. Either automatic or manual mode can be used to reset an overload (trip). Set the trip current to the rated full-load current of the motor through the overload FLA setting dial. When an overload fault occurs, the G3JA-C indicates the overload with a flashing LED indicator and closes the alarm contact.

Overtemperature

The G3JA-C monitors SCR temperature through an internal thermistor. If the SCR gets too hot, the G3JA-C turns OFF the output, indicates the overtemperature status with a flashing LED and closes the alarm contact.

Phase Reversal Protection

When this function is enabled with a DIP switch setting, the G3JA-C checks phase sequence prior to startup. If the G3JA-C detects a phase reversal fault in the main circuit power supply, it stops the starting sequence, indicates the phase reversal with a flashing LED indicator, and closes the alarm contact.

Phase Loss

The G3JA-C monitors phase loss. If phase loss lasts for two power supply frequency cycles, the G3JA-C turns OFF the output, indicates the phase loss with a flashing LED indicator and closes the alarm contact.

Current Imbalance

The G3JA-C monitors the phase current imbalance. If the imbalance exceeds the preset limit, the G3JA-C turns OFF the output, indicates the current imbalance with a flashing LED indicator and closes the alarm contact.

Shorted SCR

The G3JA-C always checks the SCR for a short circuit before the starting sequence. If a short circuit is found, the G3JA-C stops the starting sequence, indicates the short circuit with a flashing LED indicator, and closes the alarm contact.

Nomenclature

Part Names and Functions

Reset Button

All faults can be reset by pressing the Reset Button or turning OFF the control power supply. Cooling time may be required before overload and overtemperature status can be reset. Note: Test Mode for overload testing will be entered when the Reset Button is pressed for at least 1 second. Test Mode will be canceled when the Reset Button is pressed again.

Control Terminals

The G3JA-C has eight input terminals on the front. Each terminal is described in the following table.

Terminal	Description
A1	Control power supply input
A2	Control power supply common
IN1	START input
IN2	STOP input
97	NO auxiliary contact (auxiliary contact for fault detection output)
98	NO auxiliary contact (auxiliary contact for fault detection output)
13	NO auxiliary contact (normal/up-to-speed)
14	NO auxiliary contact (normal/up-to-speed)

Auxiliary Contacts

The G3JA-C is equipped with two auxiliary contacts as a standard feature. One contact can be used for fault detection output. The other one is used to output operating status and can be set to either *Normal* or *Up-to-speed* using the DIP switch setting at pin number 14.

An optional Auxiliary Contact Block can be added, and DIP switch pin number 15 can be used to set the operating status to output (either *Normal* or *Set Speed*).

Main Circuit Terminals, Power Supply Side

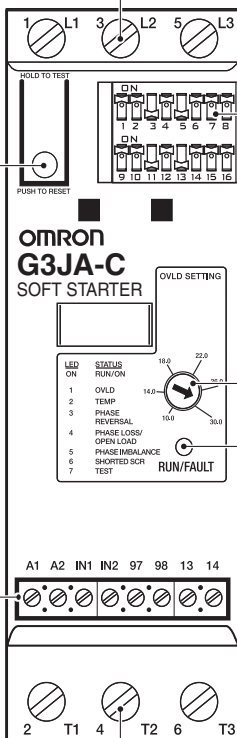

Main Circuit Terminals, Load Side

DIP Switch Configuration

Use the DIP switch to set the functions.

DIP switch pin No.	Function
1	Start time
2	
3	Start mode (current limit start or soft start)
4	Current limit start setting (when selected) or initial torque setting for a soft start (when selected)
5	
6	Soft stop
7	
8	Not used
9	Kick start
10	
11	Overload class selection
12	
13	Overload reset
14	Auxiliary contact (normal/up-to-speed)
15	Optional Auxiliary Contact Block (normal/up-to-speed)
16	Phase reversal protection

Overload FLA Setting Dial

Use this dial to set the trip current to the rated full-load current of the motor.

RUN/FAULT Indicator

The G3JA-C monitors the status before startup and during operation. One indicator indicates both normal operation (RUN) and faults (FAULT). If the G3JA-C detects a fault, it turns OFF the motor and indicates the fault with a flashing LED indicator.

The G3JA-C monitors the following conditions.

Fault	Flashing indicator status
Overload	
Over-temperature	
Phase reversal	
Phase loss	
Current imbalance	
Shorted SCR	

■ DIP Switch Settings

Start Time t1

DIP switch pin No.		Time (seconds)
1	2	
OFF	OFF	2
ON	OFF	5
OFF	ON	10
ON	ON	15

Start Mode (Current Limit Start or Soft Start)

DIP switch pin No.: 3	Setting
ON	Soft start
OFF	Current limit start

Initial Torque Setting for Soft Start

DIP switch pin No.		LRT initial torque (%)
4	5	
OFF	OFF	15%
ON	OFF	25%
OFF	ON	35%
ON	ON	65%

Current Limit Start Setting

DIP switch pin No.		FLA current limit (%)
4	5	
OFF	OFF	150%
ON	OFF	250%
OFF	ON	350%
ON	ON	450%

Soft Stop t3

DIP switch pin No.		Setting
6	7	
OFF	OFF	Coast to stop
ON	OFF	100% of the start time
OFF	ON	200% of the start time
ON	ON	300% of the start time

Kick Start t2

DIP switch pin No.		Time (seconds)
9	10	
OFF	OFF	OFF
ON	OFF	0.5
OFF	ON	1.0
ON	ON	1.5

Overload Class Selection

DIP switch pin No.		Overload class
11	12	
OFF	OFF	OFF
ON	OFF	10
OFF	ON	15
ON	ON	20

Overload Reset

DIP switch pin No.: 13	Reset
ON	Automatic
OFF	Manual

Auxiliary Contact Speed

DIP switch pin No.: 14	Setting
ON	Up-to-speed
OFF	Normal

Optional Auxiliary Relay #1

DIP switch pin No.: 15	Setting
ON	Up-to-speed
OFF	Normal

Phase Reversal Protection

DIP switch pin No.: 16	Setting
ON	Disabled
OFF	Enabled

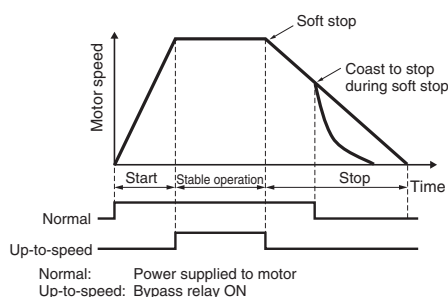

Common

Engineering Data

Trip Curves

Overload Class 10

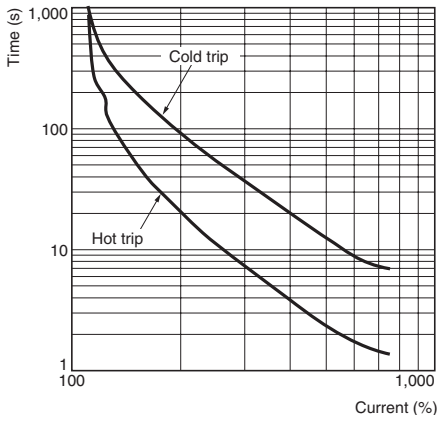

Overload Class 15

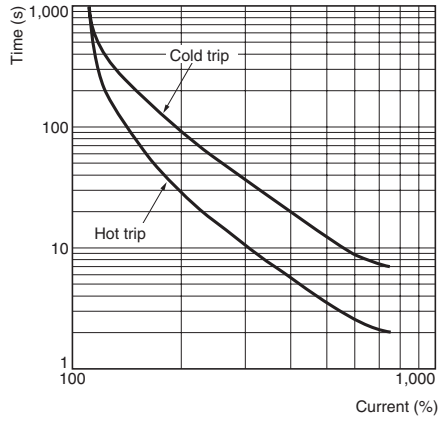

Overload Class 20

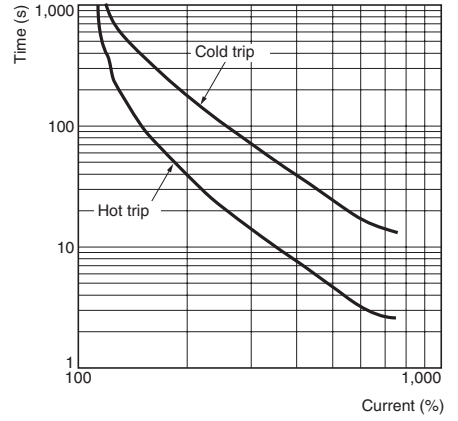

Dimensions

Note: All units are in millimeters unless otherwise indicated.

G3JA-D
G3JA-C

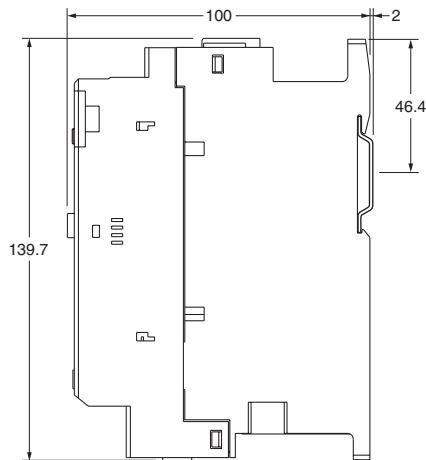
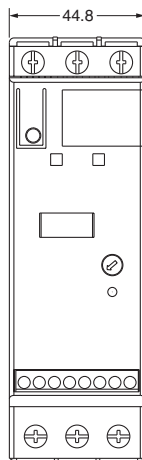
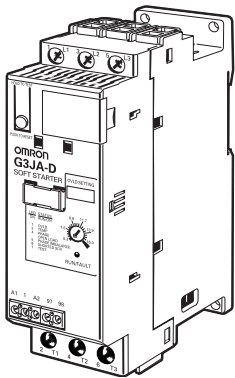

Panel Cutout Dimensions

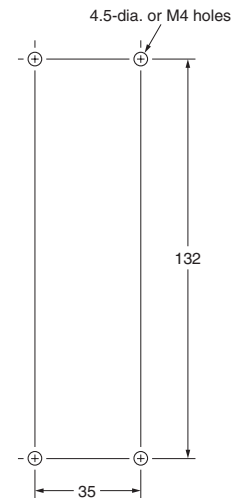

Note: Dimensions are the same for all models, regardless of the capacity. The above figure shows the G3JA-D.

■ Accessories (Order Separately)

Auxiliary Contact Blocks

G32J-CA10
G32J-CA20
G32J-CA01
G32J-CA11

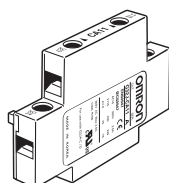

Mounting the Auxiliary Contact Block

1. Connect the connector and tabs on the G32J-CA Auxiliary Contact Block to the mounting holes on the G3JA. Be careful not to bend the connector pins.
2. Press the Block in the direction of arrow 2 in the diagram until it clicks into place.
3. Wire the Block with wires of 0.5 to 2.5 mm² (AWG 18 to AWG 14). Strip the insulation from the wires for 9 mm and tighten the terminal screws with a screwdriver to a tightening torque of 1.0 to 1.1 N·m.

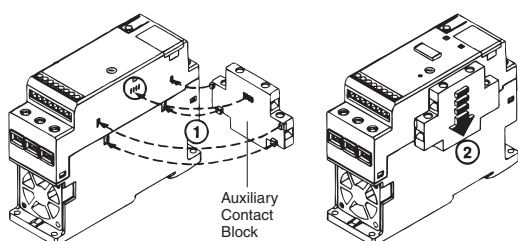

Removing the Auxiliary Contact Block

1. Press the connector at the top of the G32J-CA Auxiliary Contact Block with your finger in the direction of arrow 1 in the diagram to loosen it.
2. Pull the Block in the direction of arrow 2.
3. Pull the Block in the direction of arrow 3 and remove it.

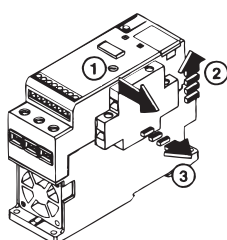

Contacts	Contact symbol	Model
1 NO		G32J-CA10
2 NO		G32J-CA20
1 NC		G32J-CA01
1 NO/1 NC		G32J-CA11

Fan

G32J-CF64

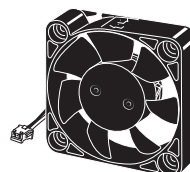

Switching is possible 4 times per hour without a Fan under the following conditions: Rated operating current, ambient temperature of 50°C max., control current of 300%, start time of 15 seconds, and ON time rate of 70%. Switching is possible 10 times per hour with a Fan under the same conditions.

Mounting the Fan

1. Align the Fan so that the arrows on the side of the Fan are pointing in the directions shown in the diagram.
2. Connect the connector on the Fan to the connector on the G3JA, pressing inward until the connector clicks into place.
3. Attach the Fan to the G3JA.

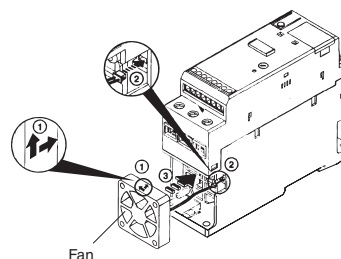

Round Terminal Block Adapters

G32J-TA10

This is the Terminal Block Adapter for wiring with round crimp terminals.

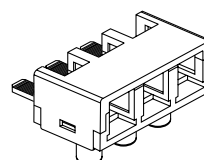

Mounting a Round Terminal Block Adapter

After wiring the Round Terminal Block Adapter, mount it to the main circuit terminals of the G3JA.

Safety Precautions

Please observe the following precautions to prevent failure to operate, malfunction, or undesirable effects on product performance.

⚠ CAUTION

Installation Environment

Always turn OFF the power supply whenever there is a possibility of coming into contact with the terminals. Otherwise, minor electric shock may occasionally occur.



Tighten all screws to the specified torque. Otherwise, fire may occasionally occur. Refer to Specifications for details.



Maintenance

When the power is turned OFF, the terminals will remain charged due to an electrolytical capacitor used in the internal circuits. Confirm that the capacitor has been completely discharged before touching any terminal. Otherwise, minor electric shock may occasionally occur.



■ Precautions for Safe Use

Operating and Storage Environments

Do not use or store the G3JA in the following locations. Doing so may result in damage, malfunction, or deterioration of performance characteristics.

- Do not use or store in locations subject to shock or vibration exceeding prescribed levels.
- Do not use or store in locations subject to exposure to water, oil, or chemicals.
- Do not use in locations subject to ambient temperatures outside the range 0 to 50°C.
- Do not store in locations subject to ambient temperatures outside the range -25 to 85°C.
- Do not use in locations subject to relative humidity outside the range 5% to 85%, or locations subject to condensation as the result of rapid changes in temperatures.
- Do not use or store in locations subject to corrosive or flammable gases.
- Do not use or store in locations subject to dust (especially iron dust) or salts.

Handling

- Do not drop the G3JA or subject it to excessive vibration or shock. Otherwise, it may fail or malfunction.
- Do not handle the G3JA with oily or dusty (especially iron dust) hands. Otherwise, it may fail.

Mounting

- The G3JA is heavy. Mount it securely to a DIN track. Make sure the DIN track is also securely mounted.
- Mount the G3JA in the specified direction. Otherwise, excessive heat generated by the G3JA may cause it to break down or catch fire.

Wiring

- Use wire that are thick enough for the load current. Otherwise, excessive heat generated by the wire may cause burning.
- Do not use wires with a damaged outer covering. Otherwise, it may result in electric shock or ground leakage.
- Do not wire any control circuit wiring in the same duct or conduit as power or high-tension lines. Otherwise, inductive noise may damage the G3JA or cause it to malfunction.

- Use only suitable wire lengths. Otherwise, inductive noise may damage the G3JA or cause it to malfunction.

Applications

- Do not allow the ambient temperature to rise due to the heat dissipated by the G3JA when two or more are installed close together. If the G3JA is mounted inside a panel, install a fan to ventilate the interior of the panel properly.
- Do not use the G3JA with a load that uses current exceeding the rated current. Otherwise the G3JA may generate excessive heat.
- Install a protective device, like a fuse or circuit breaker, on the power supply side to protect the G3JA from ground faults.
- Select a power supply within the rated frequency range of the G3JA. Otherwise, it may cause the G3JA to malfunction, fail, or burn.

■ Precautions for Correct Use

High-elevation Derating

- The efficiency of fans and heat sinks deteriorates at elevations higher than 2,000 m, requiring derating of the G3JA.

Warning Labels (Included)

When power is applied to the main circuit power supply terminals of the G3JA, the main circuit load terminals will carry current even if the G3JA is OFF. Always attach the warning labels included with the G3JA to the motor terminal box, to the G3JA, to the control panel, etc.

Main Circuit Fault Shutoff

- Safety can be increased by providing a line shutoff mechanism, such as a contactor, on the main circuit power supply to the G3JA, as shown in the following diagram. For wiring examples, refer to “Examples: Main Circuit Fault Shutoff” on page 8 for the G3JA-D and to “Examples: Main Circuit Fault Shutoff” on page 18 for the G3JA-C.

Standard Wiring Diagram for a Circuit to Shut OFF the Main Circuit for Faults

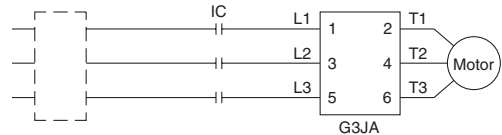

Connecting Varistors

The G3JA may be destroyed by overvoltages if there are high-energy voltage surges imposed on the AC power supply. If surge voltages are a problem, connect three varistors, one for each phase, as shown in the following diagram. The following varistors are recommended:

Be sure to install a protective device, such as a fuse or breaker, on the varistor power supply.

Varistor voltage: 910 V
Withstand energy: 200 J min. (10 × 1,000 μs)

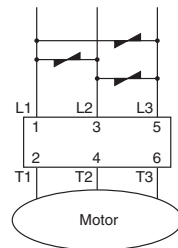

Certain Terms and Conditions of Sale

1. **Offer; Acceptance.** These terms and conditions (these "Terms") are deemed part of all catalogs, manuals or other documents, whether electronic or in writing, relating to the sale of goods or services (collectively, the "Goods") by Omron Electronics LLC and its subsidiary companies ("Seller"). Seller hereby objects to any terms or conditions proposed in Buyer's purchase order or other documents which are inconsistent with, or in addition to, these Terms. Please contact your Omron representative to confirm any additional terms for sales from your Omron company.
2. **Prices.** All prices stated are current, subject to change without notice by Seller. Buyer agrees to pay the price in effect at time of shipment.
3. **Discounts.** Cash discounts, if any, will apply only on the net amount of invoices sent to Buyer after deducting transportation charges, taxes and duties, and will be allowed only if (i) the invoice is paid according to Seller's payment terms and (ii) Buyer has no past due amounts owing to Seller.
4. **Orders.** Seller will accept no order less than \$200 net billing.
5. **Governmental Approvals.** Buyer shall be responsible for, and shall bear all costs involved in, obtaining any government approvals required for the importation or sale of the Goods.
6. **Taxes.** All taxes, duties and other governmental charges (other than general real property and income taxes), including any interest or penalties thereon, imposed directly or indirectly on Seller or required to be collected directly or indirectly by Seller for the manufacture, production, sale, delivery, importation, consumption or use of the Goods sold hereunder (including customs duties and sales, excise, use, turnover and license taxes) shall be charged to and remitted by Buyer to Seller.
7. **Financial.** If the financial position of Buyer at any time becomes unsatisfactory to Seller, Seller reserves the right to stop shipments or require satisfactory security or payment in advance. If Buyer fails to make payment or otherwise comply with these Terms or any related agreement, Seller may (without liability and in addition to other remedies) cancel any unshipped portion of Goods sold hereunder and stop any Goods in transit until Buyer pays all amounts, including amounts payable hereunder, whether or not then due, which are owing to it by Buyer. Buyer shall in any event remain liable for all unpaid accounts.
8. **Cancellation; Etc.** Orders are not subject to rescheduling or cancellation unless Buyer indemnifies Seller fully against all costs or expenses arising in connection therewith.
9. **Force Majeure.** Seller shall not be liable for any delay or failure in delivery resulting from causes beyond its control, including earthquakes, fires, floods, strikes or other labor disputes, shortage of labor or materials, accidents to machinery, acts of sabotage, riots, delay in or lack of transportation or the requirements of any government authority.
10. **Shipping; Delivery.** Unless otherwise expressly agreed in writing by Seller:
 - a. Shipments shall be by a carrier selected by Seller;
 - b. Such carrier shall act as the agent of Buyer and delivery to such carrier shall constitute delivery to Buyer;
 - c. All sales and shipments of Goods shall be FOB shipping point (unless otherwise stated in writing by Seller), at which point title to and all risk of loss of the Goods shall pass from Seller to Buyer, provided that Seller shall retain a security interest in the Goods until the full purchase price is paid by Buyer;
 - d. Delivery and shipping dates are estimates only.
 - e. Seller will package Goods as it deems proper for protection against normal handling and extra charges apply to special conditions.
11. **Claims.** Any claim by Buyer against Seller for shortage or damage to the Goods occurring before delivery to the carrier must be presented in writing to Seller within 30 days of receipt of shipment and include the original transportation bill signed by the carrier noting that the carrier received the Goods from Seller in the condition claimed.
12. **Warranties.** (a) **Exclusive Warranty.** Seller's exclusive warranty is that the Goods will be free from defects in materials and workmanship for a period of twelve months from the date of sale by Seller (or such other period expressed in writing by Seller). Seller disclaims all other warranties, express or implied. (b) **Limitations.** SELLER MAKES NO WARRANTY OR REPRESENTATION, EXPRESS OR IMPLIED, ABOUT NON-INFRINGEMENT, MERCHANTABILITY OR FITNESS FOR A PARTICULAR PURPOSE OF THE GOODS. BUYER ACKNOWLEDGES THAT IT ALONE HAS DETERMINED THAT THE GOODS WILL SUITABLY MEET THE REQUIREMENTS OF THEIR INTENDED USE. Seller further disclaims all warranties and responsibility of any type for claims or expenses based on infringement by the Goods or otherwise of any intellectual property right. (c) **Buyer Remedy.** Seller's sole obligation hereunder shall be to replace (in the form originally shipped with Buyer responsible for labor charges for removal or replacement thereof) the non-complying Good or, at Seller's election, to repay or credit Buyer an amount equal to the purchase price of the Good; provided that in no event shall Seller be responsible for warranty, repair, indemnity or any other claims or expenses regarding the Goods unless Seller's analysis confirms that the Goods were properly handled, stored, installed and maintained and not subject to contamination, abuse, misuse or inappropriate modification. Return of any goods by Buyer must be approved in writing by Seller before shipment. Seller shall not be liable for the suitability or unsuitability or the results from the use of Goods in combination with any electrical or electronic components, circuits, system assemblies or any other materials or substances or environments. Any advice, recommendations or information given orally or in writing, are not to be construed as an amendment or addition to the above warranty.
13. **Damage Limits; Etc.** SELLER SHALL NOT BE LIABLE FOR SPECIAL, INDIRECT OR CONSEQUENTIAL DAMAGES, LOSS OF PROFITS OR PRODUCTION OR COMMERCIAL LOSS IN ANY WAY CONNECTED WITH THE GOODS, WHETHER SUCH CLAIM IS BASED IN CONTRACT, WARRANTY, NEGLIGENCE OR STRICT LIABILITY. Further, in no event shall liability of Seller exceed the individual price of the Good on which liability is asserted.
14. **Indemnities.** Buyer shall indemnify and hold harmless Seller, its affiliates and its employees from and against all liabilities, losses, claims, costs and expenses (including attorney's fees and expenses) related to any claim, investigation, litigation or proceeding (whether or not Seller is a party) which arises or is alleged to arise from Buyer's acts or omissions under these Terms or in any way with respect to the Goods. Without limiting the foregoing, Buyer (at its own expense) shall indemnify and hold harmless Seller and defend or settle any action brought against Seller to the extent that it is based on a claim that any Good made to Buyer specifications infringed intellectual property rights of another party.
15. **Property; Confidentiality.** The intellectual property embodied in the Goods is the exclusive property of Seller and its affiliates and Buyer shall not attempt to duplicate it in any way without the written permission of Seller. Notwithstanding any charges to Buyer for engineering or tooling, all engineering and tooling shall remain the exclusive property of Seller. All information and materials supplied by Seller to Buyer relating to the Goods are confidential and proprietary, and Buyer shall limit distribution thereof to its trusted employees and strictly prevent disclosure to any third party.
16. **Miscellaneous.** (a) **Waiver.** No failure or delay by Seller in exercising any right and no course of dealing between Buyer and Seller shall operate as a waiver of rights by Seller. (b) **Assignment.** Buyer may not assign its rights hereunder without Seller's written consent. (c) **Amendment.** These Terms constitute the entire agreement between Buyer and Seller relating to the Goods, and no provision may be changed or waived unless in writing signed by the parties. (d) **Severability.** If any provision hereof is rendered ineffective or invalid, such provision shall not invalidate any other provision. (e) **Setoff.** Buyer shall have no right to set off any amounts against the amount owing in respect of this invoice. (f) As used herein, "including" means "including without limitation".

Certain Precautions on Specifications and Use

1. **Suitability of Use.** Seller shall not be responsible for conformity with any standards, codes or regulations which apply to the combination of the Good in the Buyer's application or use of the Good. At Buyer's request, Seller will provide applicable third party certification documents identifying ratings and limitations of use which apply to the Good. This information by itself is not sufficient for a complete determination of the suitability of the Good in combination with the end product, machine, system, or other application or use. The following are some examples of applications for which particular attention must be given. This is not intended to be an exhaustive list of all possible uses of this Good, nor is it intended to imply that the uses listed may be suitable for this Good:
 - (i) Outdoor use, uses involving potential chemical contamination or electrical interference, or conditions or uses not described in this document.
 - (ii) Energy control systems, combustion systems, railroad systems, aviation systems, medical equipment, amusement machines, vehicles, safety equipment, and installations subject to separate industry or government regulations.
 - (iii) Systems, machines and equipment that could present a risk to life or property. Please know and observe all prohibitions of use applicable to this Good.
2. **Programmable Products.** Seller shall not be responsible for the user's programming of a programmable Good, or any consequence thereof.
3. **Performance Data.** Performance data given in this catalog is provided as a guide for the user in determining suitability and does not constitute a warranty. It may represent the result of Seller's test conditions, and the user must correlate it to actual application requirements. Actual performance is subject to the Seller's Warranty and Limitations of Liability.
4. **Change in Specifications.** Product specifications and accessories may be changed at any time based on improvements and other reasons. It is our practice to change part numbers when published ratings or features are changed, or when significant construction changes are made. However, some specifications of the Good may be changed without any notice. When in doubt, special part numbers may be assigned to fix or establish key specifications for your application. Please consult with your Seller's representative at any time to confirm actual specifications of purchased Good.
5. **Errors and Omissions.** The information in this catalog has been carefully checked and is believed to be accurate; however, no responsibility is assumed for clerical, typographical or proofreading errors, or omissions.

NEVER USE THE PRODUCT FOR AN APPLICATION INVOLVING SERIOUS RISK TO LIFE OR PROPERTY WITHOUT ENSURING THAT THE SYSTEM AS A WHOLE HAS BEEN DESIGNED TO ADDRESS THE RISKS, AND THAT THE SELLER'S PRODUCT IS PROPERLY RATED AND INSTALLED FOR THE INTENDED USE WITHIN THE OVERALL EQUIPMENT OR SYSTEM.

Complete "Terms and Conditions of Sale" for product purchase and use are on Omron's website at www.omron.com/oei – under the "About Us" tab, in the Legal Matters section.

ALL DIMENSIONS SHOWN ARE IN MILLIMETERS.

To convert millimeters into inches, multiply by 0.03937. To convert grams into ounces, multiply by 0.03527.

OMRON[®]**OMRON ELECTRONICS LLC**

One Commerce Drive
Schaumburg, IL 60173

847-843-7900

For US technical support or other inquiries:

800-556-6766**OMRON CANADA, INC.**

885 Milner Avenue
Toronto, Ontario M1B 5V8

416-286-6465**OMRON ON-LINE**

Global - <http://www.omron.com>
USA - <http://www.omron.com/oei>
Canada - <http://www.omron.ca>

Looking for pricing, stock, or lifecycle information?

Click below to explore more details on WIN SOURCE:

- ⊖ [View G3JA-D416B AC100-240 on WIN SOURCE](#)
- ⊖ [Omron Information](#)

Optimize Your Supply Chain with WIN SOURCE Solutions

- ✓ Global Sourcing Solution
- ✓ Obsolete Management
- ✓ Cost Control Management
- ✓ Shortage Management
- ✓ Alternative Solution
- ✓ Excess Inventory Management