

# SPI Serial EEPROM

## 8K (8-bit wide)

### FEATURES

- Serial Peripheral Interface (SPI) Compatible
- Supports SPI Modes 0 (0,0) and 3 (1,1)
  - Data Sheet Describes Mode 0 Operation
- Low voltage and low power operations
  - FT25C08A  $V_{CC} = 1.8V$  to  $5.5V$
- 20MHz clock rate (5V)
- Maximum Standby current  $< 1\mu A$  (typically  $0.02\mu A$  and  $0.06\mu A$  @  $1.8V$  and  $5.5V$  respectively)
- Partial page write operation allowed (32 bytes page write mode)
- Self-timed programming cycle (5 ms max)
- Block Write Protection (Protect 1/4, 1/2, or Entire Array)
- Write protect pin for hardware data protection
- High reliability: typically 1,000,000 cycles endurance
- 100 years data retention
- Industrial temperature range ( $-40^{\circ}C$  to  $85^{\circ}C$ )
- Standard 8-pin DIP/SOP/TSSOP Pb-free packages

### DESCRIPTION

The FT25C08A is 8192 bits of serial Electrical Erasable and Programmable Read Only Memory, commonly known as EEPROM. They are organized as 1024 words of 8 bits (1 byte) each. The devices are fabricated with proprietary advanced CMOS process for low power and low voltage applications. These devices are available in standard 8-lead DIP, 8-lead SOP and 8-lead TSSOP packages. The memory is accessed via a simple Serial Peripheral Interface (SPI) compatible serial bus. The  $\overline{HOLD}$  pin may be used to suspend any serial communication without resetting the serial sequence. While the device is paused, transitions on its inputs will be ignored. Our extended  $V_{CC}$  range ( $1.8V$  to  $5.5V$ ) devices enables wide spectrum of applications.

**PIN CONFIGURATION**

Pin Name	Pin Function	Pin Name	Pin Function
$\overline{CS}$	Chip Select	GND	Ground
SCL	Serial Clock Input	VCC	Power Supply
SI	Serial Data Input	$\overline{WP}$	Write Protect
SO	Serial Data Output	$\overline{HOLD}$	Suspends Serial Input

All these packaging types come in conventional or Pb-free certified.

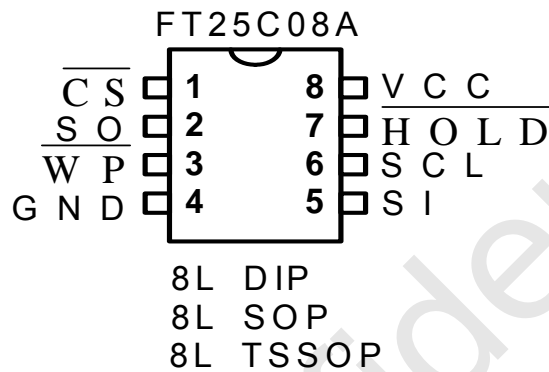

Figure 1: Packaging Types

**ABSOLUTE MAXIMUM RATINGS**

Industrial operating temperature.....	-40°C to 85°C
Storage temperature.....	-50°C to 125°C
Input voltage on any pin relative to ground.....	-0.3V to V <sub>CC</sub> + 0.3V
Maximum voltage.....	.8V
ESD protection on all pins.....	>2000V

**\* Stresses exceed those listed under “Absolute Maximum Rating” may cause permanent damage to the device. Functional operation of the device at conditions beyond those listed in the specification is not guaranteed. Prolonged exposure to extreme conditions may affect device reliability or functionality.**

**Block Diagram**

Figure 2: Block Diagram

---

**PIN DESCRIPTIONS****(A) CHIP SELECT ( $\overline{CS}$ )**

The FT25C08A is selected when the  $\overline{CS}$  pin is low. When the device is not selected, data will not be accepted via the SI pin, and the serial output pin (SO) will remain in a high impedance state.

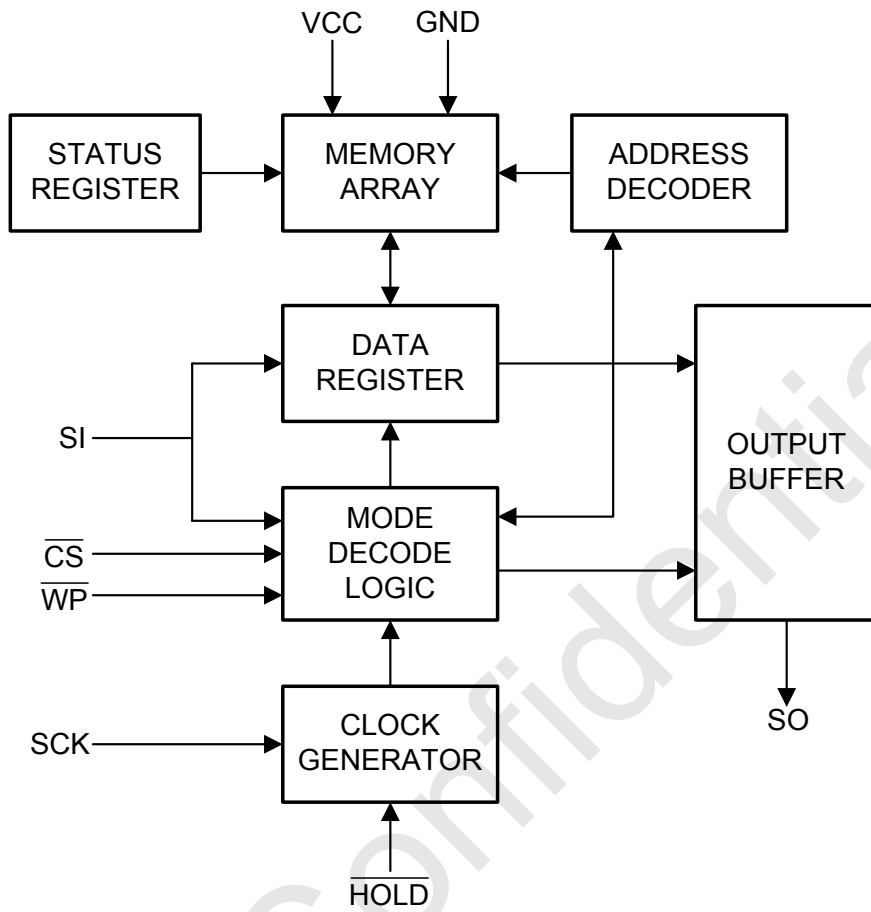
**(B) Serial Input (SI)**

The SI pin is used to transfer data into the device. It receives instructions, addresses, and data. Data is latched on the rising edge of the serial clock.

**(C) Serial Output (SO)**

The SO pin is used to transfer data out of the FT25C08A. During a read cycle, data is shifted out on this pin after the falling edge of the serial clock.

**(D) Serial Clock (SCK)**

The SCK is used to synchronize the communication between a master and the FT25C08A. Instructions, addresses, or data present on the SI pin are latched on the rising edge of the clock input, while data on the SO pin is updated after the falling edge of the clock input.

**(E) Write Protect ( $\overline{WP}$ )**

This pin is used in conjunction with the WPEN bit in the status register to prohibit writes to the non-volatile bits in the status register. When  $\overline{WP}$  is low and WPEN is high, writing to the non-volatile bits in the status register is disabled. All other operations function normally. When  $\overline{WP}$  is high, all functions, including writes to the non-volatile bits in the status register operate normally. If the WPEN bit is set,  $\overline{WP}$  low during a status register write sequence will disable writing to the status register. If an internal write cycle has already begun,  $\overline{WP}$  going low will have no effect on the write. The  $\overline{WP}$  pin function is blocked when the WPEN bit in the status register is low. This allows the user to install the FT25C08A in a system with  $\overline{WP}$  pin grounded and still be able to write to the status register. The  $\overline{WP}$  pin functions will be enabled when the WPEN bit is set high.

**(F) Hold ( $\overline{HOLD}$ )**

The  $\overline{HOLD}$  pin is used in conjunction with the  $\overline{CS}$  pin to select the FT25C08A. When the device is selected and a serial sequence is underway,  $\overline{HOLD}$  can be used to pause the serial communication with the master device without resetting the serial sequence. To pause, the  $\overline{HOLD}$  pin must be brought low while the SCK pin is low. To resume serial communication, the  $\overline{HOLD}$  pin is brought high while the SCK pin is low (SCK may still toggle during  $\overline{HOLD}$ ). Inputs to the SI pin will be ignored while the SO pin is in the high impedance state.

**MEMORY ORGANIZATION**

The FT25C08A devices have 32 pages respectively. Since each page has 32 bytes, random word addressing to FT25C08A will require 10 bits data word addresses respectively.

**DEVICE OPERATION**

The FT25C08A utilizes an 8-bit instruction register. The list of instructions and their operation codes are contained in Table A. All instructions, addresses, and data are transferred with the MSB first and start with a high-to-low  $\overline{CS}$  transition.

**Table A Instruction Set for the FT25C08A**

Instruction Name	Instruction Format	Operation
WREN	0000 X110	Set Write Enable Latch
WRDI	0000 X100	Reset Write Enable Latch
RDSR	0000 X101	Read Status Register
WRSR	0000 X001	Write Status Register
READ	0000 X011	Read Data from Memory Array
WRITE	0000 X010	Write Data to Memory Array

**(A) STATUS REGISTER OPERATION**

**Table B Status Register Format**

Bit 7	Bit 6	Bit 5	Bit 4	Bit 3	Bit 2	Bit 1	Bit 0
WPEN	X	X	X	BP1	BP0	WEN	RDY

**WRITE ENABLE (WREN):** The device will power up in the write disable state when VCC is applied. All programming instructions must therefore be preceded by a Write Enable instruction.

**WRITE DISABLE (WRDI):** To protect the device against inadvertent writes, the Write Disable instruction disables all programming modes. The WRDI instruction is independent of the status of the  $\overline{WP}$  pin.

**READ STATUS REGISTER (RDSR):** The Read Status Register instruction provides access to the status register. The READY/BUSY and Write Enable status of the device can be determined by the RDSR instruction. Similarly, the block write protection bits indicate the extent of protection employed. These bits are set by using the WRSR instruction.

**Table C Status Register Bit Definition**

Bit	Definition
Bit 0 ( $\overline{RDY}$ )	Bit 0 = "0" ( $\overline{RDY}$ ) indicates the device is READY. Bit 0 = "1" indicates the write cycle is in progress.
Bit 1 (WEN)	Bit 1 = "0" indicates the device is not WRITE ENABLED. Bit 1 = "1" indicates the device is write enabled.
Bit 2 (BP0)	See table D.
Bit 3 (BP1)	See table D.
Bits 4-6 are "0"s when device is not in an internal write cycle.	
Bit 7 (WPEN)	See table E.
Bits 0-7 are "1" during an internal write cycle.	

**WRITE STATUS REGISTER (WRSR):** The WRSR instruction allows the user to select one of four levels of protection. The FT25C08A is divided into four array segments. One-quarter, one-half, or all of the memory segments can be protected. Any of the data within any selected segment will therefore be read only. The block write protection levels and corresponding status register control bits are shown in Table D. The three bits BP0, BP1, and WPEN are nonvolatile cells that have the same properties and functions as the regular memory cells.

**Table D Block Write Protect Bits**

Level	Status Register Bits		Array Address Protected
	BP1	BP0	
0	0	0	None
1(1/4)	0	1	0300-03FF
2(1/2)	1	0	0200-03FF
3(All)	1	1	0000-03FF

The WRSR instruction also allows the user to enable or disable the write protect ( $\overline{WP}$ ) pin through the use of the Write Protect Enable (WPEN) bit. Hardware write protection is enabled when the  $\overline{WP}$  pin is low and the WPEN bit is “1”. Hardware write protection is disabled when either the  $\overline{WP}$  pin is high or the WPEN bit is “0”. When the device is hardware write protected, writes to the status register, including the block protect bits and the WPEN bit, and the block-protected sections in the memory array are disabled. Writes are only allowed to sections of the memory that are not block-protected.

**NOTE:** When the WPEN bit is hardware write protected, it cannot be changed back to “0” as long as the  $\overline{WP}$  pin is held low.

**Table E WPEN Operation**

WPEN	$\overline{WP}$	WEN	Protected Blocks	Unprotected Blocks	Status Register
0	X	0	Protected	Protected	Protected
0	X	1	Protected	Writeable	Writeable
1	Low	0	Protected	Protected	Protected
1	Low	1	Protected	Writeable	Protected
X	High	0	Protected	Protected	Protected
X	High	1	Protected	Writeable	Writeable

**(B) EEPROM OPERATION**

**READ SEQUENCE (READ):** Reading the FT25C08A via the serial output (SO) pin requires the following sequence. After the  $\overline{CS}$  line is pulled low to select a device, the read op-code is transmitted via the SI line followed by the byte address to be read (A15–A0, see Table F). Upon completion, any data on the SI line will be ignored. The data (D7–D0) at the specified address is then shifted out onto the SO line. If only one byte is to be read, the  $\overline{CS}$  line should be driven high after the data comes out. The read sequence can be continued since the byte address is automatically incremented and data will continue to be shifted out. When the highest address is reached, the address counter will roll over to the lowest address (0000h),

allowing the entire memory to be read in one continuous read cycle.

**WRITE SEQUENCE (WRITE):** In order to program the FT25C08A, two separate instructions must be executed. First, the device must be write enabled via the WREN instruction. Then a Write (WRITE) instruction may be executed. Also, the address of the memory location(s) to be programmed must be outside the protected address field location selected by the block write protection level. During an internal write cycle, all commands will be ignored except the RDSR instruction.

A Write instruction requires the following sequence. After the  $\overline{CS}$  line is pulled low to select the device, the WRITE op-code is transmitted via the SI line followed by the byte address (A15–A0) and the data (D7–D0) to be programmed (See Table F). Programming will start after the  $\overline{CS}$  pin is brought high. The low-to-high transition of the  $\overline{CS}$  pin must occur during the SCK low-time immediately after clocking in the D0 (LSB) data bit.

The FT25C08A is capable of a 32-byte page write operation. After each byte of data is received, the five low-order address bits are internally incremented by one; the high order bits of the address will remain constant. If more than 32 bytes of data are transmitted, the address counter will roll over and the previously written data will be overwritten. The FT25C08A is automatically returned to the write disable state at the completion of a write cycle.

**NOTE:** If the device is not write enabled (WREN), the device will ignore the write instruction and will return to the standby state, when  $\overline{CS}$  is brought high. A new  $\overline{CS}$  falling edge is required to reinitiate the serial communication.

The READY/BUSY status of the device can be determined by initiating a read status register (RDSR) instruction. If Bit 0 = “1”, the write cycle is still in progress. If Bit 0 = “0”, the write cycle has ended. Only the RDSR instruction is enabled during the write programming cycle.

**Table F Address Key**

Address	FT25C08A
$A_N$	$A_9-A_0$
Don't Care Bits	$A_{15}-A_{10}$

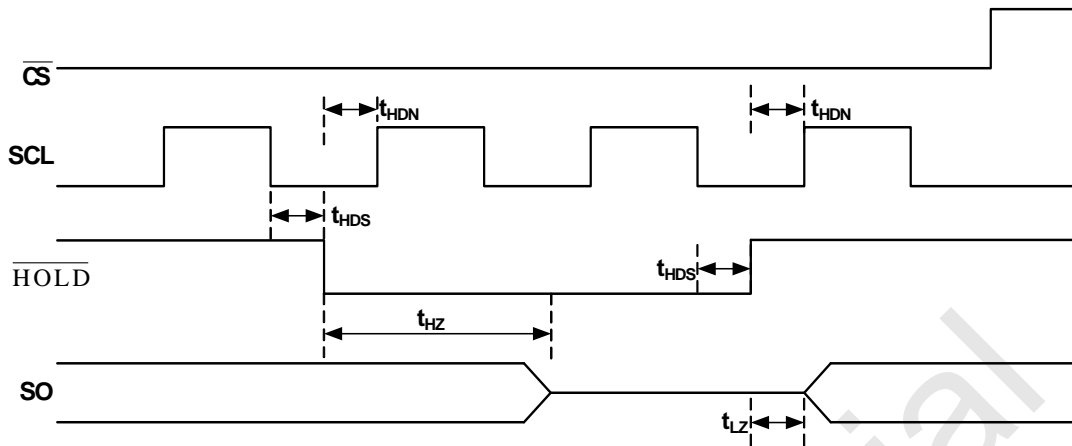

Figure 3: HOLD Timing

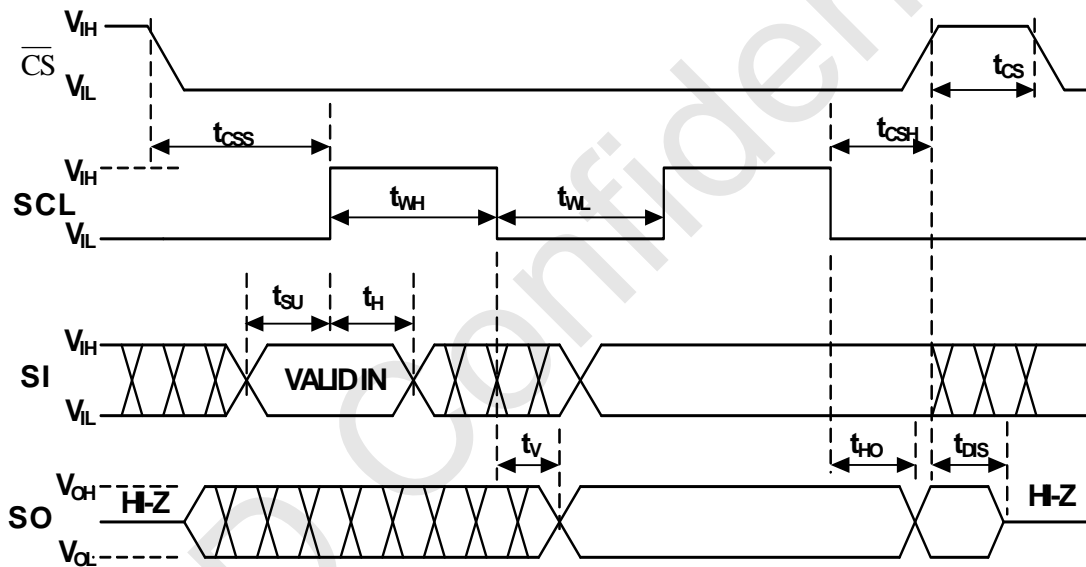

Figure 4: Synchronous Data Timing (for Mode 0)

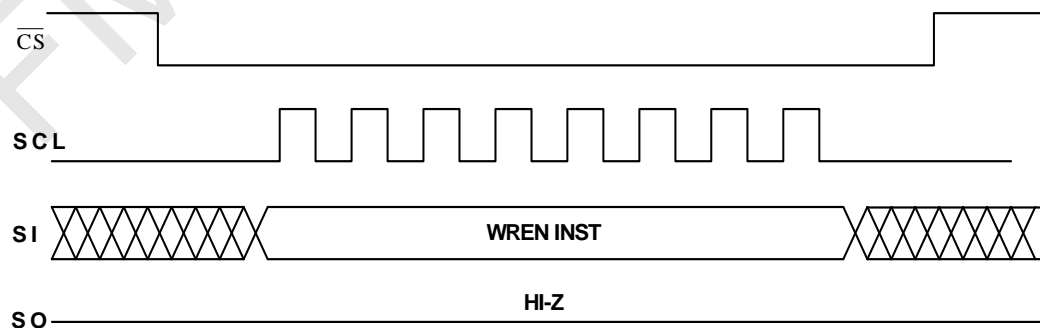

Figure 5: WREN Timing

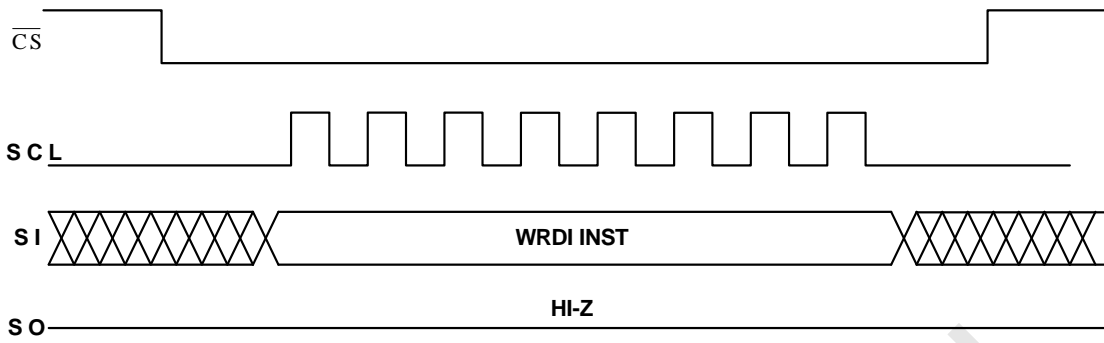

Figure 6: WRDI Timing

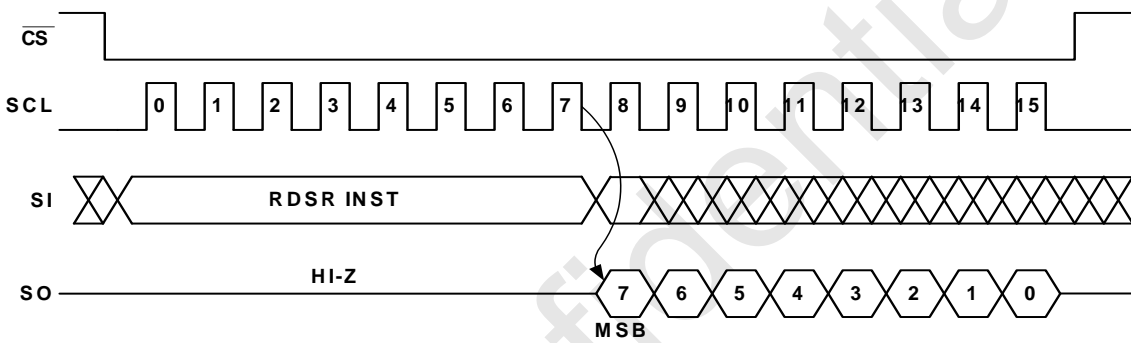

Figure 7: RDSR Timing

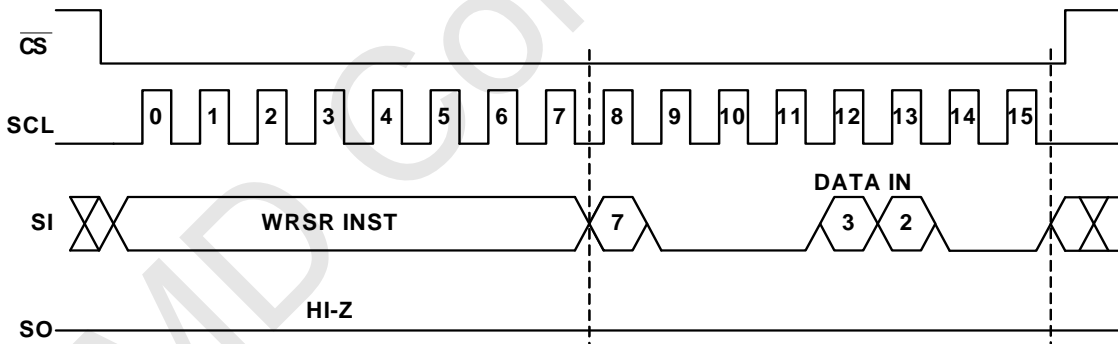

Figure 8: WRSR Timing

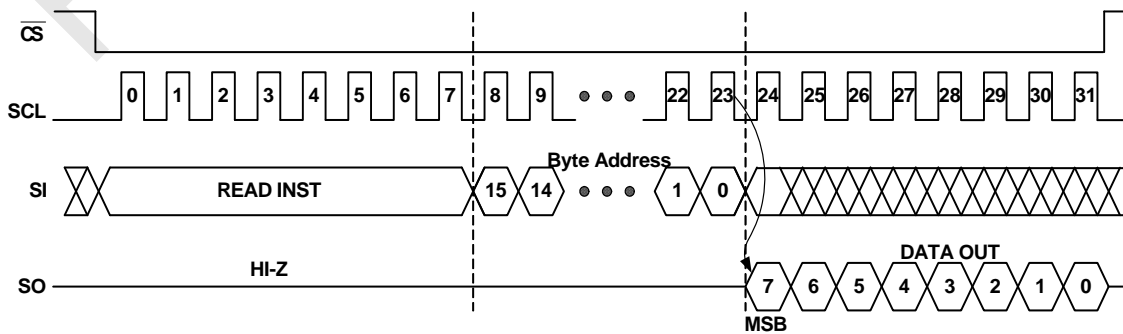

Figure 9: READ Timing

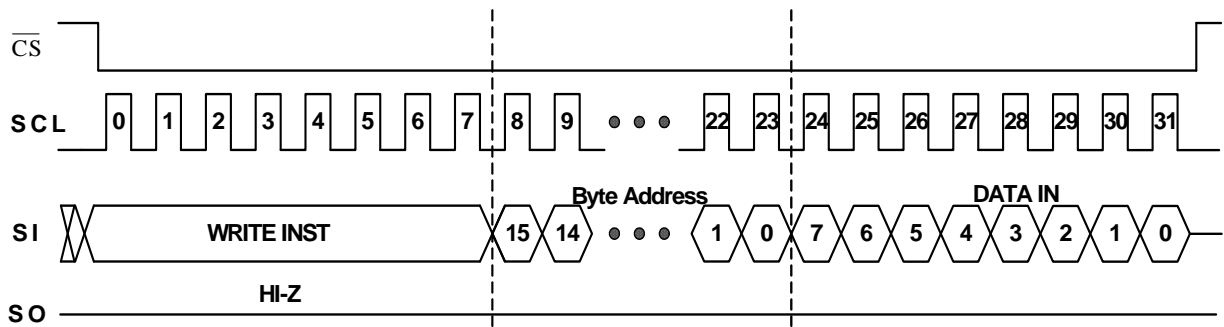

Figure 10: WRITE Timing

**AC CHARACTERISTICS**

Applicable over recommended operating range from:  $T_{AI} = -40^{\circ}C$  to  $+85^{\circ}C$ ,  $V_{CC} =$  As Specified,  $C_L = 1$  TTL Gate and 30 pF (unless otherwise noted)

Symbol	Parameter	FT25C08A						Unit
		1.8-2.7 V		2.7-4.5 V		4.5-5.5 V		
		Min	Max	Min	Max	Min	Max	
$f_{SCK}$	Clock frequency, SCK		5		10		20	MHz
$t_{RI}$	Input Rise Time		2		2		2	$\mu s$
$t_{FI}$	Input Fall Time		2		2		2	$\mu s$
$t_{WH}$	SCK High Time	80		40		20		ns
$t_{WL}$	SCK Low Time	80		40		20		ns
$t_{CS}$	$\overline{CS}$ High Time	100		50		25		ns
$t_{CSS}$	$\overline{CS}$ Setup Time	100		50		25		ns
$t_{CSH}$	$\overline{CS}$ Hold Time	100		50		25		ns
$t_{SU}$	Data In Setup Time	20		10		5		ns
$t_H$	Data In Hold Time	20		10		5		ns
$t_{HD}$	$\overline{HOLD}$ Setup Time	20		10		5		ns
$t_{CD}$	$\overline{HOLD}$ Hold Time	20		10		5		ns
$t_V$	Output Valid	0	80	0	40	0	20	ns
$t_{HO}$	Output Hold Time	0		0		0		ns
$t_{LZ}$	$\overline{HOLD}$ to Output Low Z	0	100	0	50	0	25	ns
$t_{HZ}$	$\overline{HOLD}$ to Output High Z		200		80		40	ns
$t_{DIS}$	Output Disable Time		200		80		40	ns
$t_{WC}$	Write Cycle Time		5		5		5	ms

**DC CHARACTERISTICS**

Applicable over recommended operating range from:  $T_{AI} = -40^{\circ}C$  to  $+85^{\circ}C$ ,  $V_{CC} = +1.8V$  to  $+5.5V$  (unless otherwise noted)

Symbol	Parameter	Test Conditions	Min	Typical	Max	Unit
$V_{CC1}$	Supply Voltage		1.8		5.5	V
$V_{CC2}$	Supply Voltage		2.7		5.5	V
$V_{CC3}$	Supply Voltage		4.5		5.5	V
$I_{CC1}$	Supply Current	$V_{CC}=5.0V @ 20MHz, SO=Open, Read$		7.5	10.0	mA
$I_{CC2}$	Supply Current	$V_{CC}=5.0V @ 20MHz, SO=Open, Read, Write$		4.0	10.0	mA
$I_{CC3}$	Supply Current	$V_{CC}=5.0V @ 5MHz, SO=Open, Read, Write$		4.0	6.0	mA
$I_{SB1}$	Standby current	$V_{CC} = 1.8V, \overline{CS} = V_{CC}$			1.0	$\mu A$
$I_{SB2}$	Standby current	$V_{CC} = 2.7V, \overline{CS} = V_{CC}$			1.0	$\mu A$
$I_{SB3}$	Standby current	$V_{CC} = 5.0V, \overline{CS} = V_{CC}$		0.07	1.0	$\mu A$
$I_{IL}$	Input leakage	$V_{IN} = V_{CC} \text{ or } V_{SS}$			3.0	$\mu A$
$I_{OL}$	Output leakage	$V_{IN} = V_{CC} \text{ or } V_{SS}$			3.0	$\mu A$
$V_{IL(1)}$	Input low level		-0.6		$V_{CC} \times 0.3$	V
$V_{IH(1)}$	Input high level		$V_{CC} \times 0.7$		$V_{CC} + 0.5$	V
$V_{OL1}$	Output low level	$3.6V \leq V_{CC} \leq 5.5V, I_{OL} = 3.0mA$			0.4	V
$V_{OH1}$	Output High level	$3.6V \leq V_{CC} \leq 5.5V, I_{OH} = -1.6mA$	$V_{CC} - 0.8$			
$V_{OL2}$	Output low level	$1.8V \leq V_{CC} \leq 3.6V, I_{OL} = 0.15mA$			0.2	V
$V_{OH2}$	Output High level	$1.8V \leq V_{CC} \leq 3.6V, I_{OH} = -100\mu A$	$V_{CC} - 0.2$			

Notes: 1.  $V_{IL}$  min and  $V_{IH}$  max are reference only and are not tested.

**ORDERING INFORMATION:**

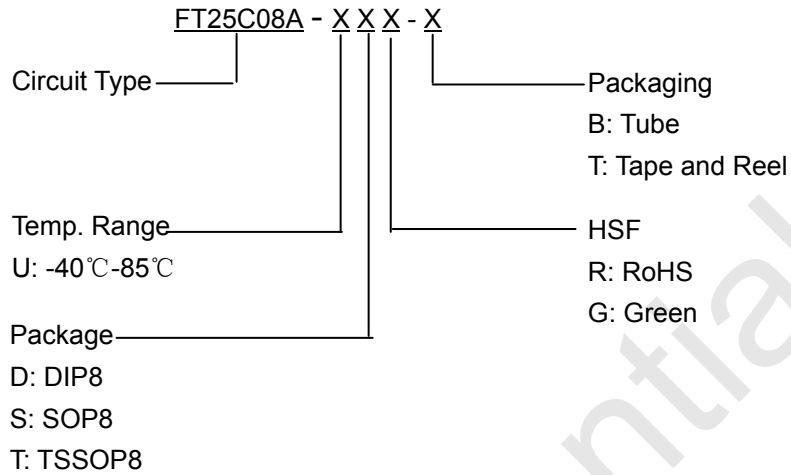

Density	Package	Temperature Range	Vcc	HSF	Packaging	Ordering Code
8kbits	DIP8	-40°C-85°C	1.8V-5.5V	RoHS	Tube	FT25C08A-UDR-B
				Green	Tube	FT25C08A-UDG-B
	SOP8	-40°C-85°C	1.8V-5.5V	RoHS	Tube	FT25C08A-USR-B
					Tape and Reel	FT25C08A-USR-T
				Green	Tube	FT25C08A-USG-B
					Tape and Reel	FT25C08A-USG-T
	TSSOP8	-40°C-85°C	1.8V-5.5V	RoHS	Tube	FT25C08A-UTR-B
					Tape and Reel	FT25C08A-UTR-T
				Green	Tube	FT25C08A-UTG-B
					Tape and Reel	FT25C08A-UTG-T

**DIP8 PACKAGE OUTLINE DIMENSIONS**

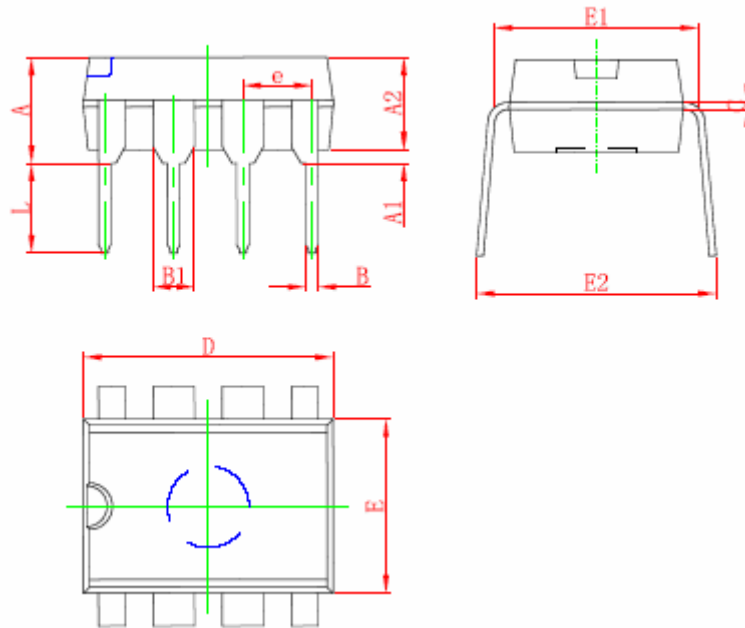

Symbol	Dimensions In Millimeters		Dimensions In Inches	
	Min	Max	Min	Max
A	3.710	4.310	0.146	0.170
A1	0.510		0.020	
A2	3.200	3.600	0.126	0.142
B	0.380	0.570	0.015	0.022
B1	1.524 (BSC)		0.060 (BSC)	
C	0.204	0.360	0.008	0.014
D	9.000	9.400	0.354	0.370
E	6.200	6.600	0.244	0.260
E1	7.320	7.920	0.288	0.312
e	2.540 (BSC)		0.100 (BSC)	
L	3.000	3.600	0.118	0.142
E2	8.400	9.000	0.331	0.354

**SOP8 PACKAGE OUTLINE DIMENSIONS**

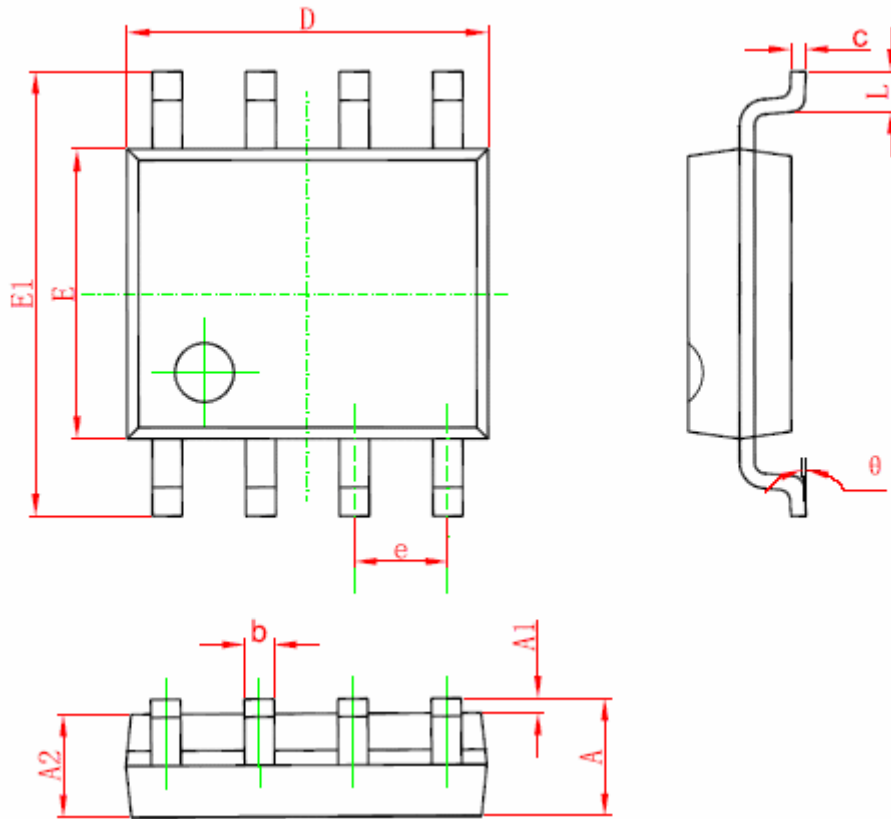

Symbol	Dimensions In Millimeters		Dimensions In Inches	
	Min	Max	Min	Max
A	1.350	1.750	0.053	0.069
A1	0.100	0.250	0.004	0.010
A2	1.350	1.550	0.053	0.061
b	0.330	0.510	0.013	0.020
c	0.170	0.250	0.006	0.010
D	4.700	5.100	0.185	0.200
E	3.800	4.000	0.150	0.157
E1	5.800	6.200	0.228	0.244
e	1.270 (BSC)		0.050 (BSC)	
L	0.400	1.270	0.016	0.050
θ	0°	8°	0°	8°

**TSSOP8 PACKAGE OUTLINE DIMENSIONS**

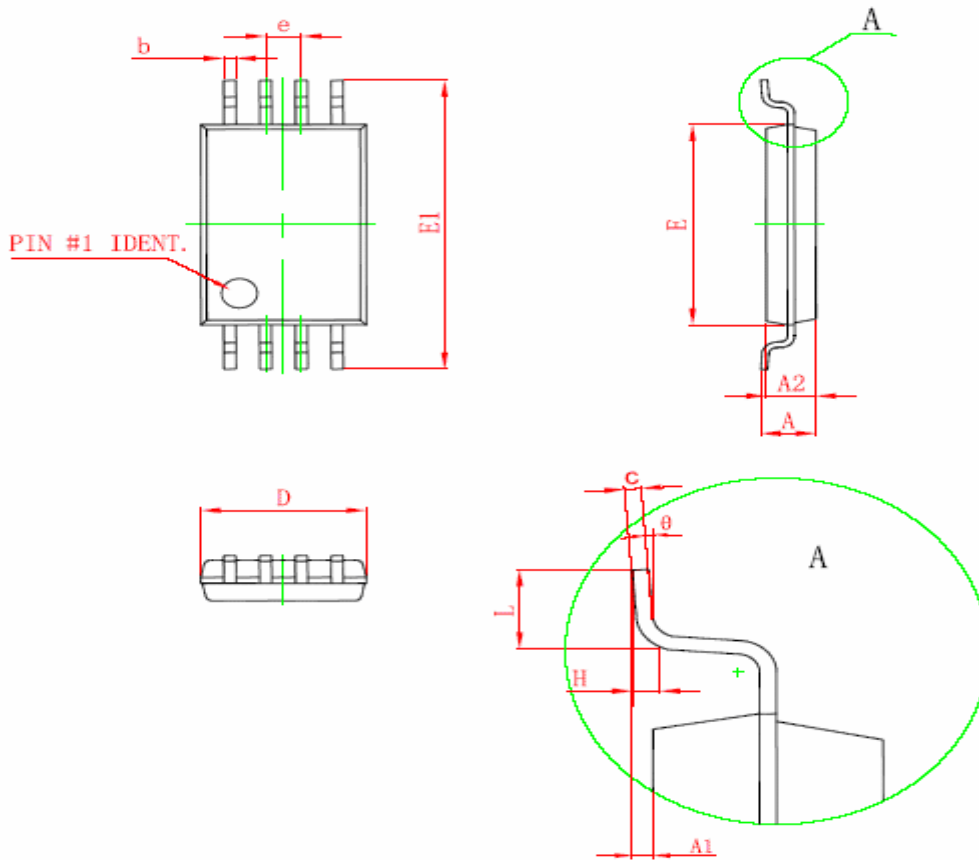

Symbol	Dimensions In Millimeters		Dimensions In Inches	
	Min	Max	Min	Max
D	2.900	3.100	0.114	0.122
E	4.300	4.500	0.169	0.177
b	0.190	0.300	0.007	0.012
c	0.090	0.200	0.004	0.008
E1	6.250	6.550	0.246	0.258
A		1.100		0.043
A2	0.800	1.000	0.031	0.039
A1	0.020	0.150	0.001	0.006
e	0.65 (BSC)		0.026 (BSC)	
L	0.500	0.700	0.020	0.028
H	0.25 (TYP)		0.01 (TYP)	
theta	1°	7°	1°	7°



**Fremont Micro Devices (SZ) Limited**

#5-8, 10/F, Changhong Building, Ke-Ji Nan 12 Road, Nanshan District, Shenzhen, Guangdong 518057

Tel: (86 755) 86117811

Fax: (86 755) 86117810

**Fremont Micro Devices (Hong Kong) Limited**

#16, 16/F, Blk B, Veristrong Industrial Centre, 34-36 Au Pui Wan Street, Fotan, Shatin, Hong Kong

Tel: (852) 27811186

Fax: (852) 27811144

**Fremont Micro Devices (USA), Inc.**

42982 Osgood Road Fremont, CA 94539

Tel: (1-510) 668-1321

Fax: (1-510) 226-9918

Web Site: <http://www.fremontmicro.com/>

\* Information furnished is believed to be accurate and reliable. However, Fremont Micro Devices, Incorporated (BVI) assumes no responsibility for the consequences of use of such information or for any infringement of patents or other rights of third parties which may result from its use. No license is granted by implication or otherwise under any patent rights of Fremont Micro Devices, Incorporated (BVI). Specifications mentioned in this publication are subject to change without notice. This publication supersedes and replaces all information previously supplied. Fremont Micro Devices, Incorporated (BVI) products are not authorized for use as critical components in life support devices or systems without express written approval of Fremont Micro Devices, Incorporated (BVI). The FMD logo is a registered trademark of Fremont Micro Devices, Incorporated (BVI). All other names are the property of their respective owners.

## Looking for pricing, stock, or lifecycle information?

Click below to explore more details on WIN SOURCE:

-  [View FT25C08A-USR-T on WIN SOURCE](#)
-  [Fremont Micro Devices USA Information](#)

## Optimize Your Supply Chain with WIN SOURCE Solutions

-  Global Sourcing Solution
-  Obsolete Management
-  Cost Control Management
-  Shortage Management
-  Alternative Solution
-  Excess Inventory Management