



**THE DATASHEET OF
FSA2567UMX**



Low-Power, Dual SIM Card Analog Switch

FSA2567

Description

The FSA2567 is a bi-directional, low-power, dual double-pole, double-throw (4PDT) analog switch targeted at dual SIM card multiplexing. It is optimized for switching the WLAN-SIM data and control signals and dedicates one channel as a supply-source switch.

The FSA2567 is compatible with the requirements of SIM cards and features a low on capacitance (C_{ON}) of 10 pF to ensure high-speed data transfer. The V_{SIM} switch path has a low R_{ON} characteristic to ensure minimal voltage drop in the dual SIM card supply paths.

The FSA2567 contains special circuitry that minimizes current consumption when the control voltage applied to the SEL pin is lower than the supply voltage (V_{CC}). This feature is especially valuable in ultra-portable applications, such as cell phones; allowing direct interface with the general-purpose I/Os of the baseband processor. Other applications include switching and connector sharing in portable cell phones, PDAs, digital cameras, printers, and notebook computers.

Features

- Low On Capacitance for Data Path: 10 pF Typical
- Low On Resistance for Data Path: 6 Ω Typical
- Low On Resistance for Supply Path: 0.4 Ω Typical
- Wide V_{CC} Operating Range: 1.65 V to 4.3 V
- Low Power Consumption: 1 μ A Maximum
 - ◆ 15 μ A Maximum I_{CCT} Over Expanded Voltage Range ($V_{IN} = 1.8$ V, $V_{CC} = 4.3$ V)
- Wide -3 db Bandwidth: >160 MHz
- Packaged in:
 - ◆ Pb-free 16-Lead MLP & 16-Lead UMLP
- 3 kV ESD Rating, >12 kV Power/GND ESD Rating

Applications

- Cell Phone, PDA, Digital Camera, and Notebook
- LCD Monitor, TV, and Set-Top Box

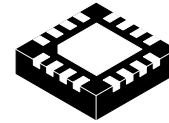

WQFN16 3x3, 0.5P
CASE 510BS

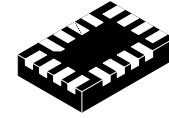

UQFN16 1.8x2.6, 0.4P
CASE 523BF

MARKING DIAGRAM

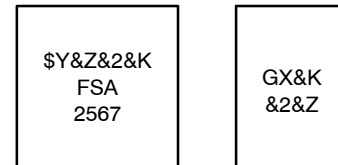

GX, FSA2567 = Device Code
 \$Y = onsemi Logo
 &Z = Assembly Plant Code
 &2 = 2-Digit Date Code
 &K = 2-Digits Lot Run Traceability Code

ORDERING INFORMATION

See detailed ordering and shipping information on page 2 of this data sheet.

FSA2567

ORDERING INFORMATION

Part Number	Top Mark	Operating Temperature Range	Package	Shipping†
FSA2567MPX	FSA2567	-40 to +85°C	16-Lead, Molded Leadless Package (MLP) Quad, JEDEC MO-220, 3 mm Square	3000 / Tape & Reel
FSA2567UMX	GX		16-Lead, Quad, Ultrathin Molded Leadless Package (UMLP), 1.8 x 2.6 mm	5000 / Tape & Reel

†For information on tape and reel specifications, including part orientation and tape sizes, please refer to our Tape and Reel Packaging Specifications Brochure, BRD8011/D.

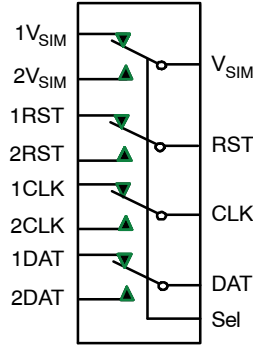

Figure 1. Analog Symbol

PIN ASSIGNMENTS

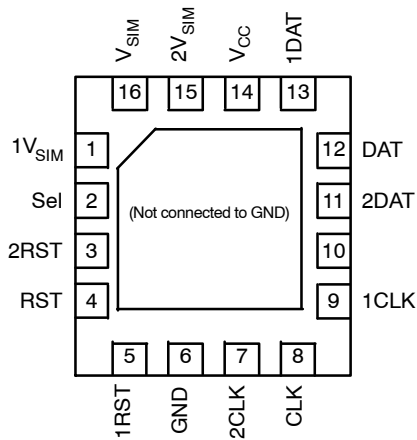

Figure 2. Pad Assignment MLP16 (Top Through View)

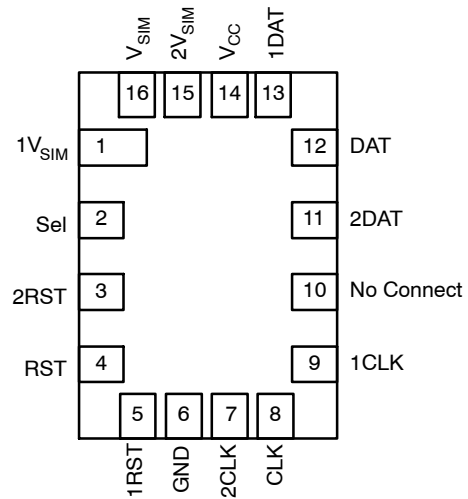

Figure 3. Pad Assignment UMLP16 (Top Through View)

PIN DESCRIPTION

Pin No.	Description
nDAT, nRST, nCLK	Multiplexed Data Source Inputs
nV _{SIM}	Multiplexed SIM Supply Inputs
V _{SIM} , DAT, RST, CLK	Common SIM Ports
Sel	Switch Select

FSA2567

TRUTH TABLE

Sel	Function
Logic LOW	1DAT = DAT, 1RST = RST, 1CLK = CLK, 1V _{SIM} = V _{SIM}
Logic HIGH	2DAT = DAT, 2RST = RST, 2CLK = CLK, 2V _{SIM} = V _{SIM}

ABSOLUTE MAXIMUM RATINGS

Symbol	Parameter	Min	Max	Unit	
V _{CC}	Supply Voltage	-0.5	+5.5	V	
V _{CNTRL}	DC Input Voltage (Sel) (Note 1)	-0.5	V _{CC}	V	
V _{SW}	DC Switch I/O Voltage (Note 1)	-0.5	V _{CC} + 0.3	V	
I _{IK}	DC Input Diode Current	-50	-	mA	
I _{SIM}	DC Output Current – V _{SIM}	-	350	mA	
I _{OUT}	DC Output Current – DAT, CLK, RST	-	35	mA	
T _{STG}	Storage Temperature	-65	+150	°C	
ESD	Human Body Model, JEDEC: JESD22-A114	All Pins	-	3	kV
		I/O to GND	-	12	
	Charged Device Model, JEDEC: JESD22-C101		-	2	

Stresses exceeding those listed in the Maximum Ratings table may damage the device. If any of these limits are exceeded, device functionality should not be assumed, damage may occur and reliability may be affected.

1. The input and output negative ratings may be exceeded if the input and output diode current ratings are observed.

RECOMMENDED OPERATING CONDITIONS

Symbol	Parameter	Min	Max	Unit
V _{CC}	Supply Voltage	1.65	4.30	V
V _{CNTRL}	Control Input Voltage (Sel) (Note 2)	0	V _{CC}	V
V _{SW}	Switch I/O Voltage	-0.5	V _{CC}	V
I _{SIM}	DC Output Current – V _{SIM}	-	150	mA
I _{OUT}	DC Output Current – DAT, CLK, RST	-	25	mA
TA	Operating Temperature	-40	+85	°C

Functional operation above the stresses listed in the Recommended Operating Ranges is not implied. Extended exposure to stresses beyond the Recommended Operating Ranges limits may affect device reliability.

2. The control input must be held HIGH or LOW; it must not float.

FSA2567

DC ELECTRICAL CHARACTERISTICS (All typical values are at 25°C, 3.3 V V_{CC} unless otherwise specified.)

Symbol	Parameter	Conditions	V_{CC} (V)	$T_A = -40^\circ\text{C to } 85^\circ\text{C}$			Unit
				Min	Typ	Max	
V_{IK}	Clamp Diode Voltage	$I_{IN} = -18 \text{ mA}$	2.7	-	-	-1.2	V
V_{IH}	Input Voltage High		1.65 to 2.3	1.1	-	-	V
			2.7 to 3.6	1.3	-	-	
			4.3	1.7	-	-	
V_{IL}	Input Voltage Low		1.65 to 2.3	-	-	0.4	V
			2.7 to 3.6	-	-	0.5	
			4.3	-	-	0.7	
I_{IN}	Control Input Leakage	$V_{SW} = 0 \text{ to } V_{CC}$	4.3	-1	-	1	μA
$I_{nc(off)}, I_{no(off)}$	Off State Leakage	nRST, nDAT, nCLK, $nV_{SIM} = 0.3 \text{ V}$ or 3.6 V Figure 10	4.3	-60	-	60	nA
R_{OND}	Data Path Switch On Resistance (Note 3)	$V_{SW} = 0, 1.8 \text{ V}, I_{ON} = -20 \text{ mA}$ Figure 9	1.8	-	7.0	12.0	Ω
		$V_{SW} = 0, 2.3 \text{ V}, I_{ON} = -20 \text{ mA}$ Figure 9	2.7	-	6.0	10.0	
R_{ONV}	V_{SIM} Switch On Resistance (Note 3)	$V_{SW} = 0, 1.8 \text{ V}, I_{ON} = -100 \text{ mA}$ Figure 9	1.8	-	0.5	0.7	Ω
		$V_{SW} = 0, 2.3 \text{ V}, I_{ON} = -100 \text{ mA}$ Figure 9	2.7	-	0.4	0.6	
ΔR_{OND}	Data Path Delta On Resistance (Note 4)	$V_{SW} = 0 \text{ V}, I_{ON} = -20 \text{ mA}$	2.7	-	0.2	-	Ω
I_{CC}	Quiescent Supply Current	$V_{CNTRL} = 0 \text{ or } V_{CC}, I_{OUT} = 0$	4.3	-	-	1.0	μA
I_{CCT}	Increase in I_{CC} Current Per Control Voltage and V_{CC}	$V_{CNTRL} = 2.6 \text{ V}, V_{CC} = 4.3 \text{ V}$	4.3	-	5.0	10.0	μA
		$V_{CNTRL} = 1.8 \text{ V}, V_{CC} = 4.3 \text{ V}$	4.3	-	7.0	15.0	μA

3. Measured by the voltage drop between nDAT, nRST, nCLK and relative common port pins at the indicated current through the switch. On resistance is determined by the lower of the voltage on the relative ports.
4. Guaranteed by characterization.

FSA2567

AC ELECTRICAL CHARACTERISTICS (All typical values are for $V_{CC} = 3.3\text{ V}$ at 25°C unless otherwise specified.)

Symbol	Parameter	Conditions	V_{CC} (V)	$T_A = -40^\circ\text{C to } 85^\circ\text{C}$			Unit
				Min	Typ	Max	
t_{OND}	Turn-On Time Sel to Output (DAT, CLK, RST)	$R_L = 50\ \Omega$, $C_L = 35\ \text{pF}$ $V_{SW} = 1.5\ \text{V}$ Figure 11, Figure 12	1.8 (Note 5)	-	65	95	ns
			2.7 to 3.6	-	42	60	ns
t_{OFFD}	Turn-Off Time Sel to Output (DAT, CLK, RST)	$R_L = 50\ \Omega$, $C_L = 35\ \text{pF}$ $V_{SW} = 1.5\ \text{V}$ Figure 11, Figure 12	1.8 (Note 5)	-	30	50	ns
			2.7 to 3.6	-	20	40	ns
t_{ONV}	Turn-On Time Sel to Output (V_{SIM})	$R_L = 50\ \Omega$, $C_L = 35\ \text{pF}$ $V_{SW} = 1.5\ \text{V}$ Figure 11, Figure 12	1.8 (Note 5)	-	55	80	ns
			2.7 to 3.6	-	35	55	ns
t_{OFFV}	Turn-Off Time Sel to Output (V_{SIM})	$R_L = 50\ \Omega$, $C_L = 35\ \text{pF}$ $V_{SW} = 1.5\ \text{V}$ Figure 11, Figure 12	1.8 (Note 5)	-	35	50	
			2.7 to 3.6	-	22	40	ns
t_{PD}	Propagation Delay (Note 5) (DAT, CLK, RST)	$C_L = 35\ \text{pF}$, $R_L = 50\ \Omega$ Figure 11, Figure 13	3.3	-	0.25	-	ns
t_{BBMD}	Break-Before-Make (Note 5) (DAT, CLK, RST)	$R_L = 50\ \Omega$, $C_L = 35\ \text{pF}$ $V_{SW1} = V_{SW2} = 1.5\ \text{V}$ Figure 15	2.7 to 3.6	3	18	-	ns
t_{BBMV}	Break-Before-Make (Note 5) (V_{SIM})	$R_L = 50\ \Omega$, $C_L = 35\ \text{pF}$ $V_{SW1} = V_{SW2} = 1.5\ \text{V}$ Figure 15	2.7 to 3.6	3	12	-	ns
Q	Charge Injection (DAT, CLK, RST)	$C_L = 50\ \text{pF}$, $R_{GEN} = 0\ \Omega$, $V_{GEN} = 0\ \text{V}$	2.7 to 3.6	-	10	-	pC
O_{IRR}	Off Isolation (DAT, CLK, RST)	$R_L = 50\ \Omega$, $f = 10\ \text{MHz}$ Figure 17	2.7 to 3.6	-	-60	-	dB
Xtalk	Non-Adjacent Channel Crosstalk (DAT, CLK, RST)	$R_L = 50\ \Omega$, $f = 10\ \text{MHz}$ Figure 18	2.7 to 3.6	-	-60	-	dB
BW	-3 db Bandwidth (DAT, CLK, RST)	$R_L = 50\ \Omega$, $C_L = 5\ \text{pF}$ Figure 16	2.7 to 3.6	-	475	-	MHz

5. Guaranteed by characterization.

CAPACITANCE

Symbol	Parameter	Conditions	$T_A = -40^\circ\text{C to } 85^\circ\text{C}$			Unit
			Min	Typ	Max	
C_{IN}	Control Pin Input Capacitance	$V_{CC} = 0\ \text{V}$	-	1.5	-	pF
C_{OND}	RST, CLK, DAT On Capacitance (Note 6)	$V_{CC} = 3.3\ \text{V}$, $f = 1\ \text{MHz}$, Figure 20	-	10	12	
C_{ONV}	V_{SIM} On Capacitance (Note 6)	$V_{CC} = 3.3\ \text{V}$, $f = 1\ \text{MHz}$, Figure 20	-	110	150	
C_{OFFD}	RST, CLK, DAT Off Capacitance	$V_{CC} = 3.3\ \text{V}$, Figure 19	-	3	-	
C_{OFFV}	V_{SIM} Off Capacitance	$V_{CC} = 3.3\ \text{V}$, Figure 19	-	40	-	

6. Guaranteed by characterization.

TYPICAL PERFORMANCE CHARACTERISTICS

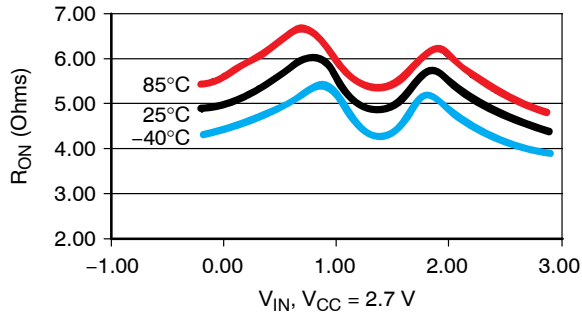

Figure 4. RON Data Path

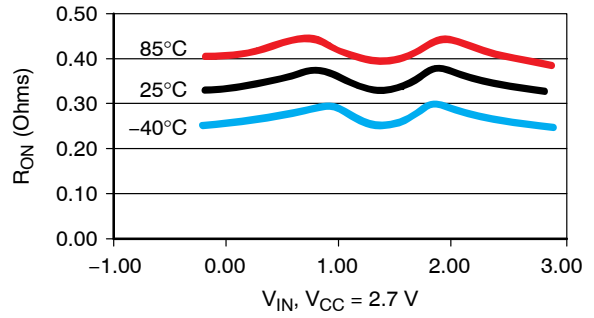

Figure 5. RON Vsim

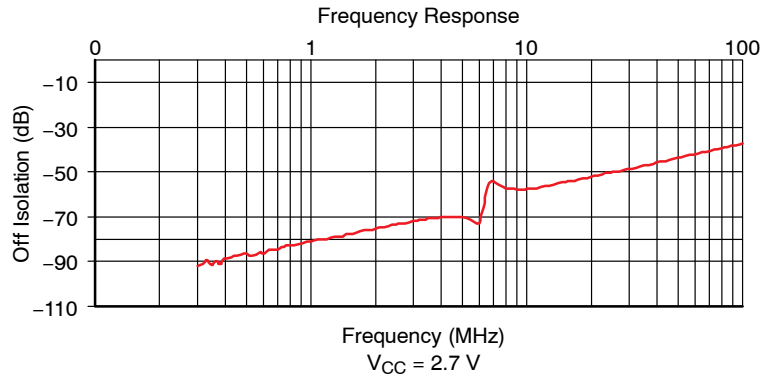

Figure 6. Off Isolation

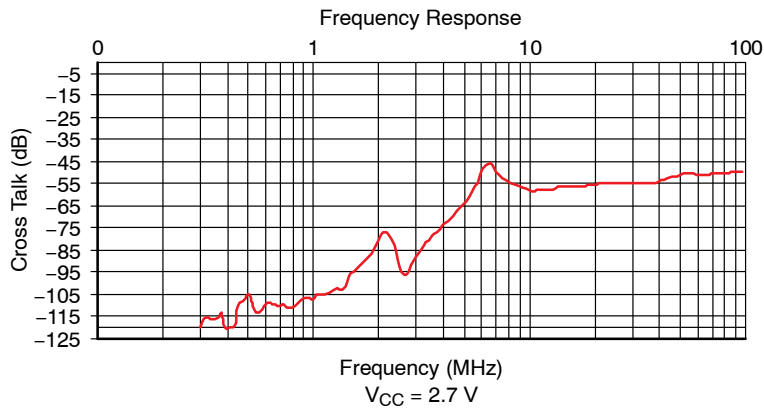

Figure 7. Crosstalk

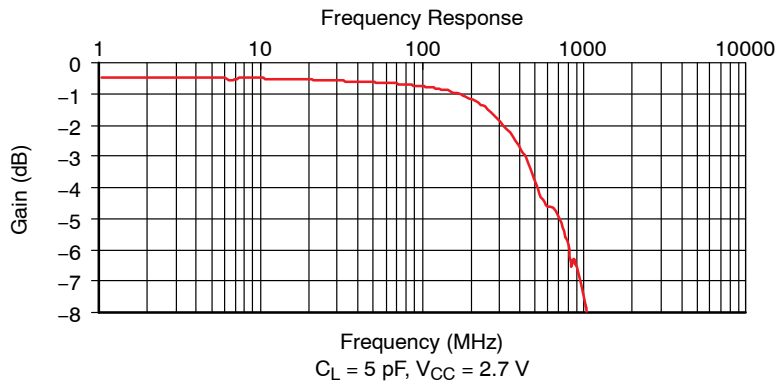

Figure 8. Bandwidth

TEST DIAGRAMS

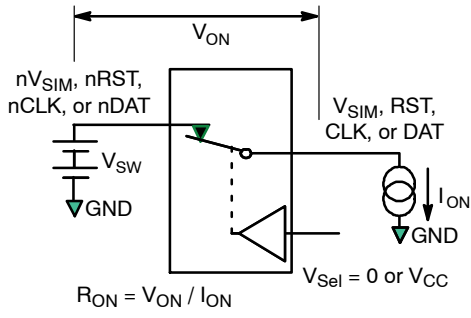

Figure 9. On Resistance

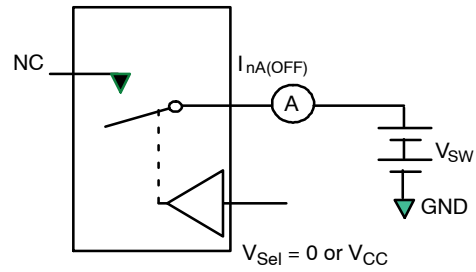
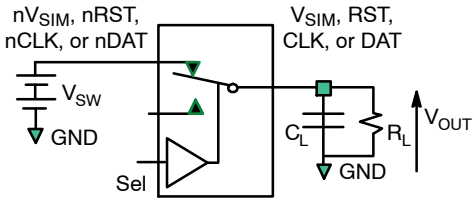

Figure 10. Off Leakage



R_L and C_L are functions of the application environment (see tables for specific values). C_L includes test fixture and stray capacitance.

Figure 11. AC Test Circuit Load

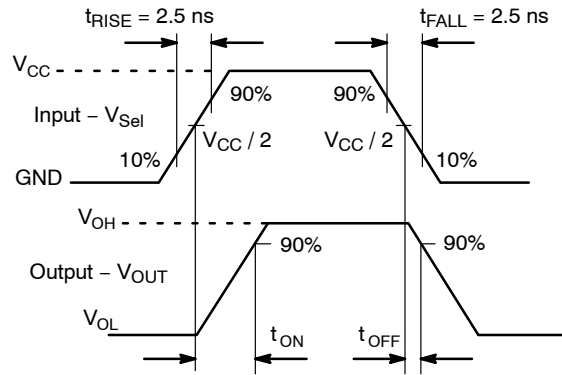

Figure 12. Turn-On / Turn-Off Waveforms

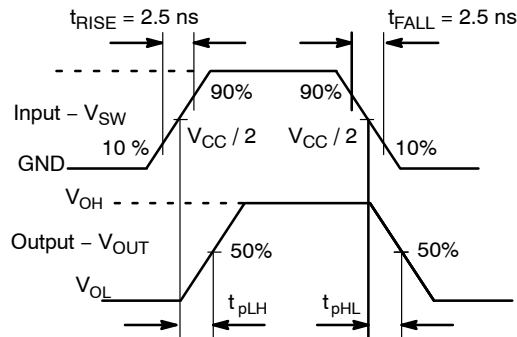

Figure 13. Propagation Delay

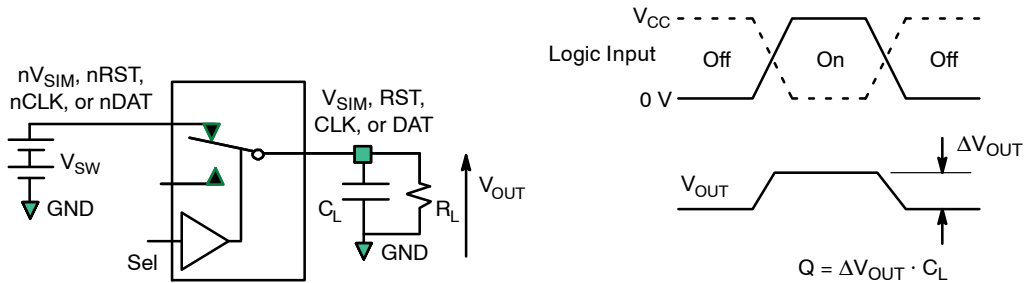

Figure 14. Charge Injection

TEST DIAGRAMS (Continued)

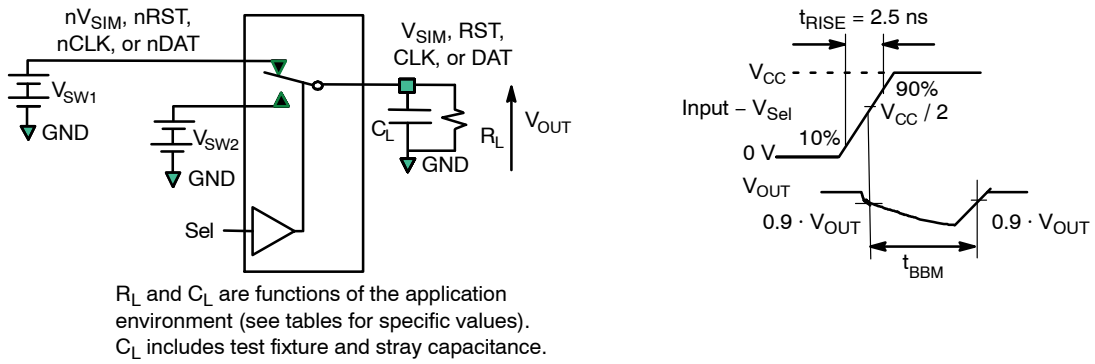

Figure 15. Break-Before-Make Interval Timing

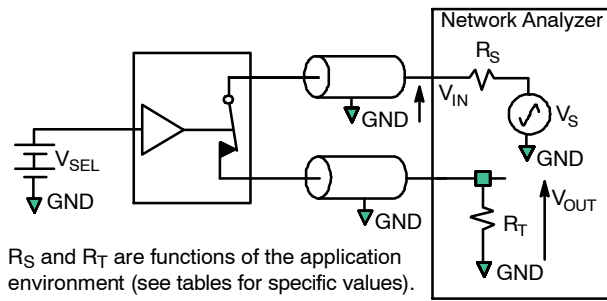
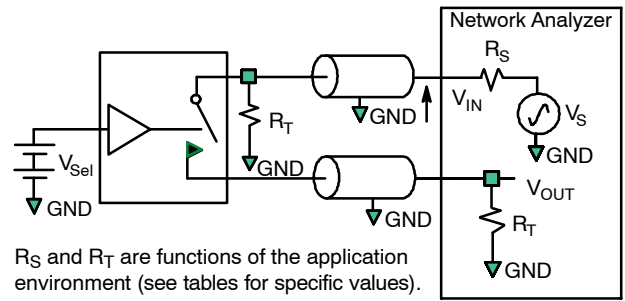
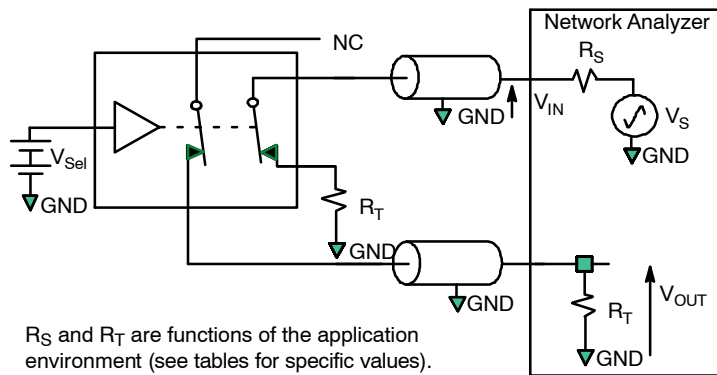

Figure 16. Bandwidth



Off isolation = $20 \text{ Log } (V_{OUT} / V_{IN})$

Figure 17. Channel Off Isolation



Crosstalk = $20 \text{ Log } (V_{OUT} / V_{IN})$

Figure 18. Non-Adjacent Channel-to-Channel Crosstalk

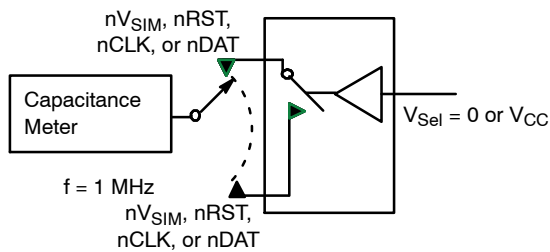

Figure 19. Channel Off Capacitance

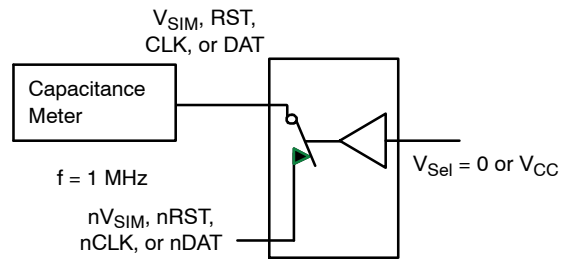
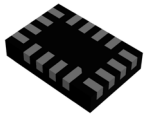

Figure 20. Channel On Capacitance

MECHANICAL CASE OUTLINE PACKAGE DIMENSIONS



UQFN16 1.80x2.60x0.50, 0.40P
CASE 523BF
ISSUE A

DATE 06 MAY 2024

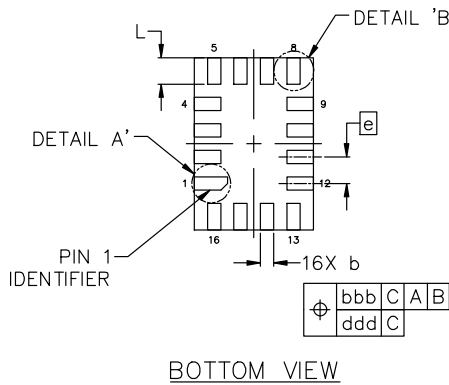
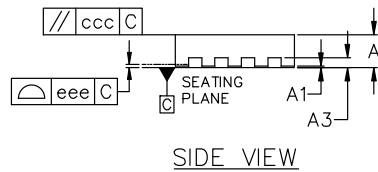
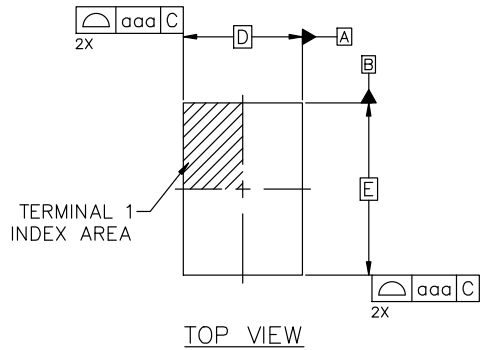

NOTES:

1. DIMENSIONING AND TOLERANCING CONFORM TO ASME Y14.5M-2018.
2. ALL DIMENSIONS ARE IN MILLIMETERS, DEGREES IN ANGLE.
3. LAND PATTERN RECOMMENDATION IS EXISTING INDUSTRY LAND PATTERN.
4. TERMINAL SHAPE MAY VARY ACCORDING TO PACKAGE SUPPLIER, SEE TERMINAL SHAPE VARIANTS.

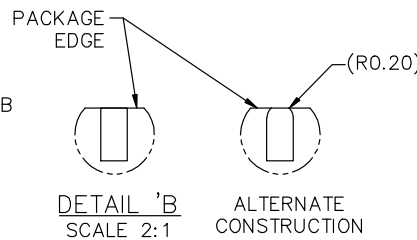
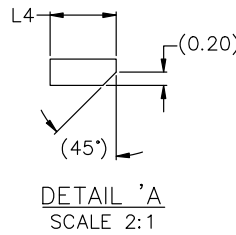

DIM	MILLIMETERS		
	MIN	NOM	MAX
A	0.45	0.50	0.55
A1	0.00	---	0.05
A3	0.10	0.15	0.20
b	0.15	0.20	0.25
D	1.80 BSC		
E	2.60 BSC		
e	0.40 BSC		
L	0.35	0.40	0.45
L4	0.45	0.50	0.55
TOLERANCES FOR FEATURE CONTROL FRAME			
aaa	0.05		
bbb	0.10		
ccc	0.10		
ddd	0.05		
eee	0.05		

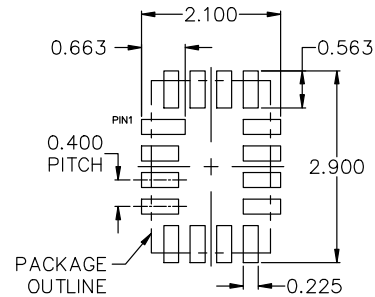

*FOR ADDITIONAL INFORMATION ON OUR Pb-FREE STRATEGY AND SOLDERING DETAILS, PLEASE DOWNLOAD THE ONSEMI SOLDERING AND MOUNTING TECHNIQUES REFERENCE MANUAL, SOLDERRM/D.

DOCUMENT NUMBER:	98AON13709G	Electronic versions are uncontrolled except when accessed directly from the Document Repository. Printed versions are uncontrolled except when stamped "CONTROLLED COPY" in red.
DESCRIPTION:	UQFN16 1.80x2.60x0.50, 0.40P	PAGE 1 OF 1

onsemi and ONSEMI are trademarks of Semiconductor Components Industries, LLC dba onsemi or its subsidiaries in the United States and/or other countries. onsemi reserves the right to make changes without further notice to any products herein. onsemi makes no warranty, representation or guarantee regarding the suitability of its products for any particular purpose, nor does onsemi assume any liability arising out of the application or use of any product or circuit, and specifically disclaims any and all liability, including without limitation special, consequential or incidental damages. onsemi does not convey any license under its patent rights nor the rights of others.

onsemi, **Onsemi**, and other names, marks, and brands are registered and/or common law trademarks of Semiconductor Components Industries, LLC dba "**onsemi**" or its affiliates and/or subsidiaries in the United States and/or other countries. **onsemi** owns the rights to a number of patents, trademarks, copyrights, trade secrets, and other intellectual property. A listing of **onsemi**'s product/patent coverage may be accessed at www.onsemi.com/site/pdf/Patent-Marking.pdf. **onsemi** reserves the right to make changes at any time to any products or information herein, without notice. The information herein is provided "as-is" and **onsemi** makes no warranty, representation or guarantee regarding the accuracy of the information, product features, availability, functionality, or suitability of its products for any particular purpose, nor does **onsemi** assume any liability arising out of the application or use of any product or circuit, and specifically disclaims any and all liability, including without limitation special, consequential or incidental damages. Buyer is responsible for its products and applications using **onsemi** products, including compliance with all laws, regulations and safety requirements or standards, regardless of any support or applications information provided by **onsemi**. "Typical" parameters which may be provided in **onsemi** data sheets and/or specifications can and do vary in different applications and actual performance may vary over time. All operating parameters, including "Typicals" must be validated for each customer application by customer's technical experts. **onsemi** does not convey any license under any of its intellectual property rights nor the rights of others. **onsemi** products are not designed, intended, or authorized for use as a critical component in life support systems or any FDA Class 3 medical devices or medical devices with a same or similar classification in a foreign jurisdiction or any devices intended for implantation in the human body. Should Buyer purchase or use **onsemi** products for any such unintended or unauthorized application, Buyer shall indemnify and hold **onsemi** and its officers, employees, subsidiaries, affiliates, and distributors harmless against all claims, costs, damages, and expenses, and reasonable attorney fees arising out of, directly or indirectly, any claim of personal injury or death associated with such unintended or unauthorized use, even if such claim alleges that **onsemi** was negligent regarding the design or manufacture of the part. **onsemi** is an Equal Opportunity/Affirmative Action Employer. This literature is subject to all applicable copyright laws and is not for resale in any manner.

ADDITIONAL INFORMATION

TECHNICAL PUBLICATIONS:

Technical Library: www.onsemi.com/design/resources/technical-documentation
onsemi Website: www.onsemi.com

ONLINE SUPPORT: www.onsemi.com/support

For additional information, please contact your local Sales Representative at www.onsemi.com/support/sales



Looking for pricing, stock, or lifecycle information?

Click below to explore more details on WIN SOURCE:

- ⊖ [View FSA2567UMX on WIN SOURCE](#)
- ⊖ [Fairchild/ON Semiconductor Information](#)

Optimize Your Supply Chain with WIN SOURCE Solutions

- ✓ Global Sourcing Solution
- ✓ Obsolete Management
- ✓ Cost Control Management
- ✓ Shortage Management
- ✓ Alternative Solution
- ✓ Excess Inventory Management