



**THE DATASHEET OF
FRC20C2A6R8JTP**



Specification

Title: CHIP FUSIBLE RESISTORS; RECTANGULAR TYPE

Style: FRC16, 20, 32

RoHS COMPLIANCE ITEM

Halogen and Antimony Free

Product specification contained in this specification
are subject to change at any time without notice
If you have any questions or a Purchasing Specification for any quality
Agreement is necessary, please contact our sales staff.



釜屋電機株式会社
KAMAYA ELECTRIC CO., LTD.

Hokkaido Research Center
Approval by: T. Sannomiya
Drawing by: M. Shibuya

Note: Stock conditions

Temperature: +5°C ~ +35°C

Relative humidity: 25% ~ 75%

The period of guarantee: Within 2 year from shipment by the company.

Solderability shall be satisfied.

1. Scope

1.1 This specification covers the detail requirements for chip fusible resistors; rectangular type, style of FRC16, 20,32.

1.2 Applicable documents

JIS C 5201: 1994, JIS C 5202: 1990

2. Classification

Type designation shall be the following form.

(Example)

FRC	20	C	2A	100	J	TP
1	2	3	4	5	6	7

 Style

1 Chip fusible resistors; rectangular type  Style

2 Size

3 Characteristics symbol

4 Rated dissipation

Symbol	Rated dissipation
1J	0.063W
2A	0.1W
2B	0.125W

5 Rated resistance

100	E24 Series, 3 digit, EX. 100-->10Ω
-----	------------------------------------

6 Tolerance on rated resistance

J	±5%
---	-----

7 Packaging form

B	Bulk (loose package)
TP	Paper taping

3. Rating

3.1 The ratings shall be in accordance with Table-1.

Table-1

Style	Rated dissipation (W)	Temperature coefficient of resistance (10 ⁻⁶ /°C)	Rated resistance range(Ω)	Preferred number series for resistors	Tolerance on rated resistance
FRC16	0.063	± 500	3.9~51	E24	J(±5%)
FRC20	0.1	± 1000	1.0~51		
FRC32	0.125	± 500	56~100		
		± 1000	1.0~51		

Style	Limiting element voltage (V)	Max. overload voltage(V)	Fusing characteristics			Operating temperature range(°C)
			Symbol	Fusing power (W)	Fusing time (s.)	
FRC16	1.79	3.58	C	1.89	30 max.	-55~+125
FRC20	2.26	4.52		2.0		
FRC32	3.53	7.06		2.5		

3.2 Derating

The derated values of dissipation at temperature in excess of 70 °C shall be as indicated by the following curve.

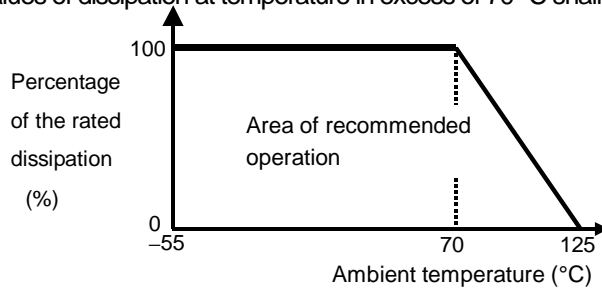

Figure-1 Derating curve

3.3 Rated voltage

d.c.or a.c.r.m.s.voltage calculated from the square root of the product of the rated resistance and the rated dissipation.

$$E = \sqrt{P \cdot R}$$

E: Rated voltage (V)

P: Rated dissipation (W)

R: Rated resistance (Ω)

Max. overload voltage can only be applied to resistors when the resistance value is equal to or higher than the critical resistance value.

At high value of resistance, the rated voltage may not be applicable.

4. Packaging form

The standard packaging form shall be in accordance with Table-2.

Table-2

Symbol	Packaging form		Standard packaging quantity / units
B	Bulk (loose package)		1,000 pcs.
TP	Paper taping	8mm width, 4mm pitches	5,000 pcs.

5. Dimensions

5.1 The resistor shall be of the design and physical dimensions in accordance with Figure-2 and Table-3.

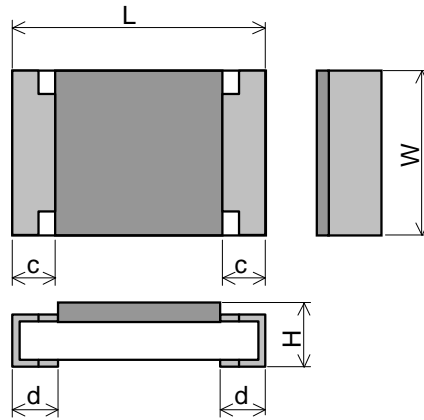

Figure-2

Table-3

Unit: mm

Style	L	W	H	C	d
FRC16	1.6 ± 0.1	$0.8 \begin{smallmatrix} +0.15 \\ -0.05 \end{smallmatrix}$	0.45 ± 0.10	0.3 ± 0.1	0.3 ± 0.1
FRC20	2.0 ± 0.1	1.25 ± 0.10	0.6 ± 0.1	0.4 ± 0.2	0.4 ± 0.2
FRC32	3.2 ± 0.2	1.6 ± 0.15	0.6 ± 0.1	0.5 ± 0.25	0.5 ± 0.25

5.2 Net weight (Reference)

Style	Net weight(mg)
FRC16	2.2
FRC20	6
FRC32	10

6. Marking

The Rated resistance shall be marked in 3 digits (E24) and marked on over coat side.

(Example) "100" → $10 \times 10^0 [\Omega]$ → $10 [\Omega]$

7. Performance

7.1 The standard condition for tests shall be in accordance with Sub-clause 3, JIS C 5202: 1990.

7.2 The performance shall be satisfied in Table-4.

Table-4(1)

No.	Test items	Condition of test (JIS C 5202)	Performance requirements
1	Resistance	Sub-clause 5.1 Classification of test voltage: A	Within the specified tolerance of rated resistance.
2	Temperature characteristic resistance of	Sub-clause 5.2 The resistor shall be mounted on the test substrate as shown in Figure-3-2. Test resistance shall be measured at the room temp. and temp. about 100 °C higher than the room temp..	See Table-1.
3	Short time overload	Sub-clause 5.5 The resistor shall be mounted on the test substrate as shown in Figure-3-2. Test potential: 2 times rated voltage. Test period: 5 s. Test potential should not exceed limiting element voltage as shown in Table-1.	Within $\pm (5\%+0.1\Omega)$ No evidence of appearance damage
4	Insulation resistance	Sub-clause 5.6 The resistor shall be fixed on the test fixture as shown in Figure-5 Test potential: FRC16:100Vdc FRC20,32: 500Vdc Test period: 1 min.	1,000M Ω min.
5	Voltage proof	Sub-clause 5.7 The resistor shall be fixed on the test fixture as shown in Figure-5 Test condition: Normal pressure Test potential: FRC16: 100Vac FRC20,32: 500Vac Test period: 60 ⁺¹⁰ ₀ s.	No flashover, fire and breakdown.
6	Fusing characteristic	Sub-clause 8.6 of EIAJ RC-2124 The resistor shall be mounted on the test substrate as shown in Figure-3-1. Fusing power; FRC16: 1.89W FRC20: 2.0W FRC32: 2.5W Test condition: No draught over the resistors. The voltage which corresponds to fusing power shall be applied until fusing. After the fusing tests, the remaining resistance shall be measured according to No.1.	Characteristics: C ●Fusing time: 30 s. max. ●The remaining resistance shall be exceeded more than 50 times against initial resistance. ●No smoke and arc.
7	Bond strength of the face plating	Sub-clause 6.1.4(1) The resistor shall be mounted on the test substrate as shown in Figure-4. Bending value: 5 mm (Among the fulcrums: 90 mm) Duration: 10 \pm 1 s	Within \pm 1% No evidence of mechanical damage

Table-4(2)

No.	Test items	Condition of test (JIS C 5202)	Performance requirements															
8	Vibration	Sub-clause 6.3 The resistor shall be mounted on the test substrate as shown in Figure-3-2. Class of vibration: A 3 directions perpendicular to the above and to each other. Duration of vibration: 2h in each directions.	Within $\pm 1\%$ No evidence of mechanical damage															
9	Resistance to soldering heat	Sub-clause 6.10 Test by a piece. Temp. of solder bath: $260\text{ }^{\circ}\text{C} \pm 5\text{ }^{\circ}\text{C}$ Immersion time: $10\text{ s} \pm 1\text{ s}$ After immersion into solder, leaving at the room temp. for 1h or more and then measure the resistance.	Within $\pm 3\%$ No evidence of appearance damage															
10	Solderability	Sub-clause 6.11 Test by a piece. Flux: Rosin-Methanol Temp. of solder bath: $235\text{ }^{\circ}\text{C} \pm 5\text{ }^{\circ}\text{C}$ Immersion time: $2\text{ s} \pm 0.5\text{ s}$	The surface of terminal immersed shall be min. of 95% covered with a new coating of solder.															
11	Temperature cycling	Sub-clause 7.4 The resistor shall be mounted on the test substrate as shown in Figure-3-2. Test cycle: 5 cycles for duty cycle as specified below.	Within $\pm 5\%$ No evidence of appearance damage															
		<table border="1"> <thead> <tr> <th>Step</th> <th>Temperature ($^{\circ}\text{C}$)</th> <th>Time (min)</th> </tr> </thead> <tbody> <tr> <td>1</td> <td>Room temp.</td> <td>2-3</td> </tr> <tr> <td>2</td> <td>-55 ± 3</td> <td>30</td> </tr> <tr> <td>3</td> <td>Room temp.</td> <td>2-3</td> </tr> <tr> <td>4</td> <td>125 ± 2</td> <td>30</td> </tr> </tbody> </table>		Step	Temperature ($^{\circ}\text{C}$)	Time (min)	1	Room temp.	2-3	2	-55 ± 3	30	3	Room temp.	2-3	4	125 ± 2	30
		Step		Temperature ($^{\circ}\text{C}$)	Time (min)													
		1		Room temp.	2-3													
		2		-55 ± 3	30													
3	Room temp.	2-3																
4	125 ± 2	30																
12	Load life in humidity	Sub-clause 7.9 The resistor shall be mounted on the test substrate as shown in Figure-3-2. Test temp. & relative humidity: $40\text{ }^{\circ}\text{C} \pm 2\text{ }^{\circ}\text{C}$ & 90-95 % Test voltage: Cycle of 1 h 30 min. "ON" and 30 min. "OFF" at dc rated voltage. Test period: $1,000^{+48}_0\text{ h}$	Within $\pm 5\%$ No evidence of appearance damage															
13	Endurance at $70\text{ }^{\circ}\text{C}$	Sub-clause 7.10 The resistor shall be mounted on the test substrate as shown in Figure-3-2. Test temp. & relative humidity: $70\text{ }^{\circ}\text{C} \pm 2\text{ }^{\circ}\text{C}$ Test voltage: Cycle of 1 h 30 min. "ON" and 30 min. "OFF" at dc rated voltage. Test period: $1,000^{+48}_0\text{ h}$	Within $\pm 5\%$ No evidence of appearance damage															

8. Test substrate

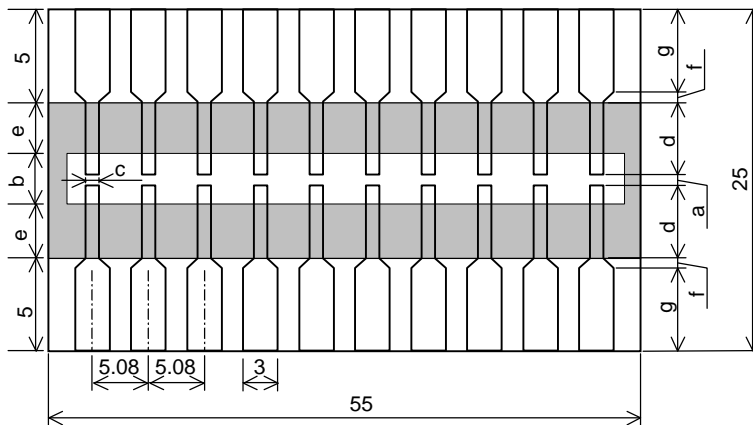

Unit:mm

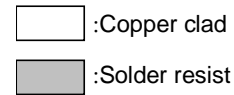

Style	a	b	c	d	e	f	g
FRC16	1.0	3.6	1.0	7.0	5.7	1.25	3.75
FRC20	1.2	4.0	1.65	6.9	5.5	1.25	3.75
FRC32	2.2	5.0	2.0	6.4	5.0	0.75	4.25

FRC TEST SUBSTRATE

Figure-3-1

Remark 1). Material: Epoxide woven glass

Thickness: 1.6mm Thickness of copper clad: 0.035mm

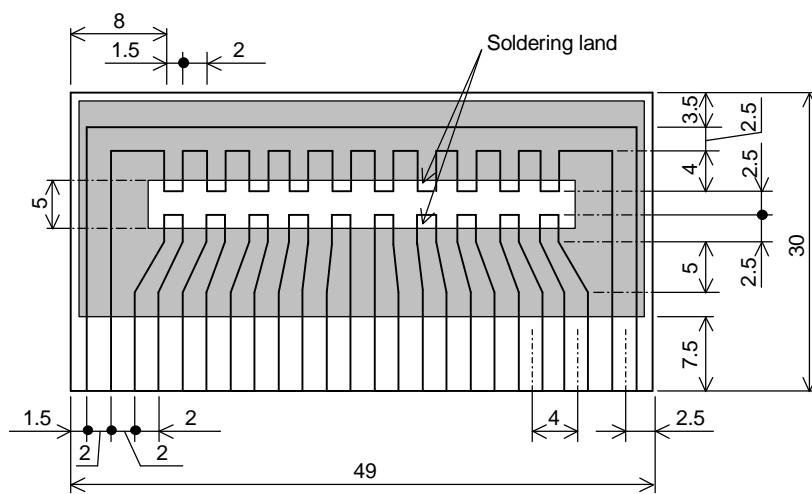

Unit: mm

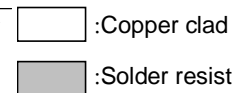

FRC32 TEST SUBSTRATE

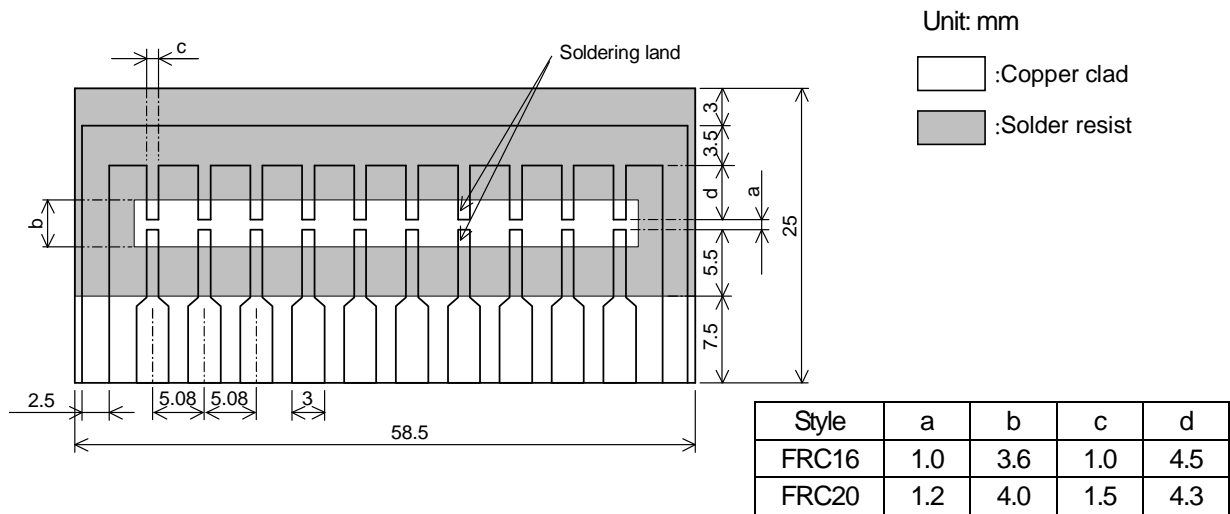

FRC16, 20 TEST SUBSTRATE

Figure-3-2

- Remark 1). Material: Epoxide woven glass
Thickness: 1.6mm Thickness of copper clad: 0.035mm
- 2). In the case of connection by connector, the connecting terminals are gold plated.
However, the plating is not necessary when the connection is made by soldering.

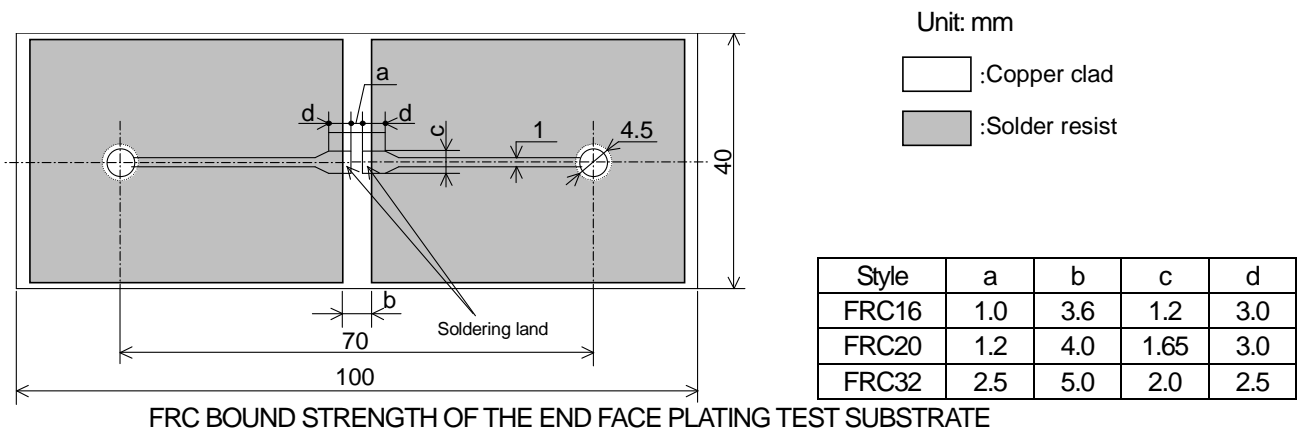

FRC BOUND STRENGTH OF THE END FACE PLATING TEST SUBSTRATE

Figure-4

- Remark 1). Material: Epoxide woven glass
Thickness: 1.6mm Thickness of copper clad: 0.035mm

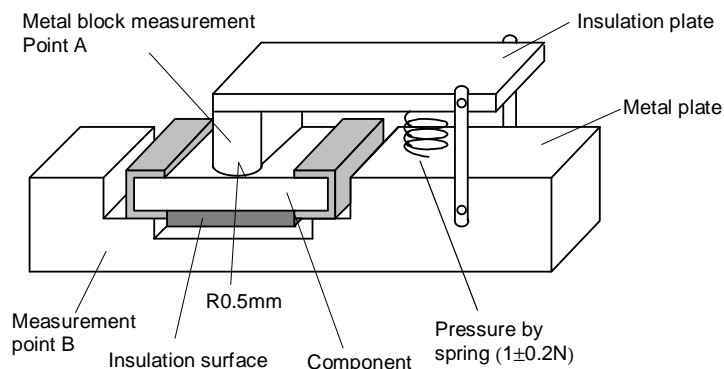

Figure-5

9. Taping

9.1 Applicable documents JIS C 0806-3: 2014, EIAJ ET-7200C: 2010

9.2 Taping dimensions

Paper taping (8mm width, 4mm pitches)

Taping dimensions shall be in accordance with Figure-6 and Table-5.

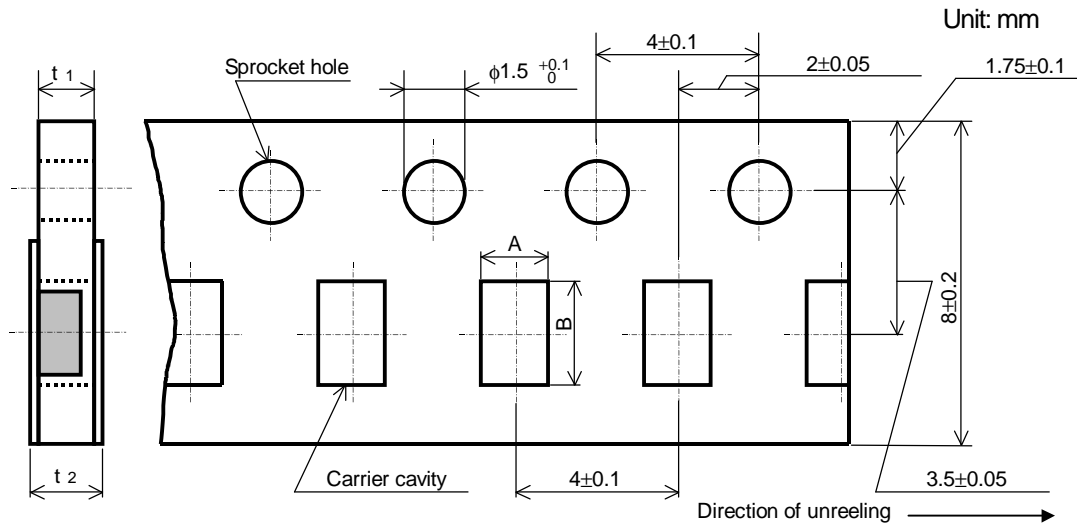

Figure-6

Table-5

Unit: mm

Style	A	B	t ₁	t ₂
FRC16	1.15 ± 0.15	1.9 ± 0.2	0.6 ± 0.1	0.8max.
FRC20	1.65 ± 0.15	2.5 ± 0.2	0.8 ± 0.1	1.0max.
FRC32	2.00 ± 0.15	3.6 ± 0.2		

- 1). The cover tapes shall not cover the sprocket holes.
- 2). Tapes in adjacent layers shall not stick together in the packing.
- 3). Components shall not stick to the carrier tape or to the cover tape.
- 4). Pitch tolerance over any 10 pitches ± 0.2 mm.
- 5). The peel strength of the top cover tape shall be within 0.1N to 0.5N on the test method as shown in the following Figure-7.
- 6). When the tape is bent with the minimum radius for 25 mm, the tape shall not be damaged and the components shall maintain their position and orientation in the tape.
- 7). In no case shall there be two or more consecutive components missing.
 The maximum number of missing components shall be one or 0.1%, whichever is greater.
- 8). The resistors shall be faced to upward at the over coating side in the carrier cavity.

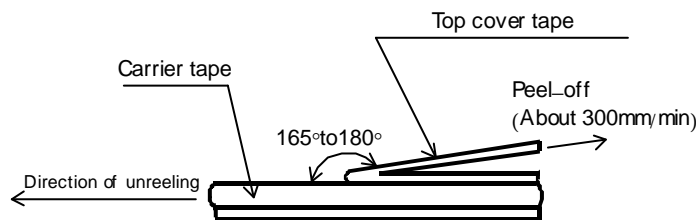

Figure-7

9.3 Reel dimension

Reel dimensions shall be in accordance with the following Figure-8 and Table-6.

Plastic reel (Based on EIAJ ET-7200C)

Unit: mm

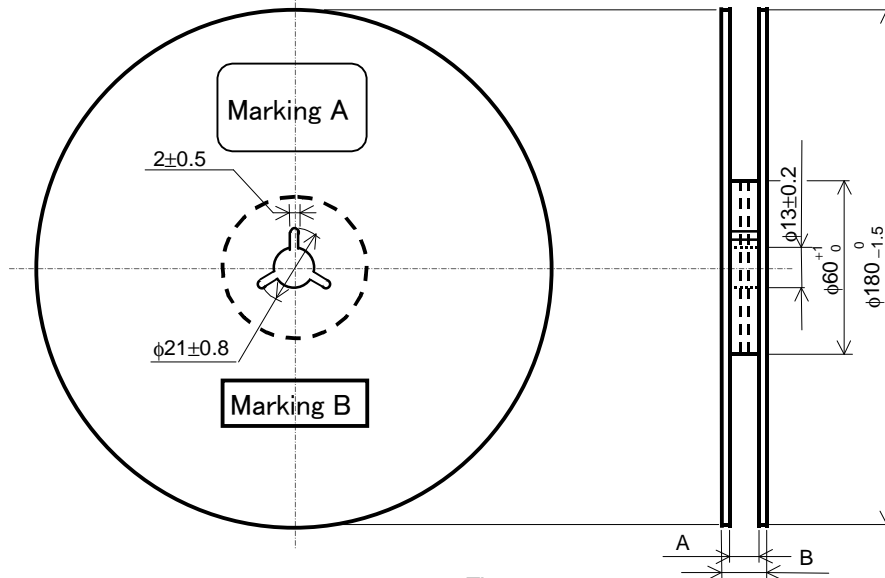

Figure-8

Table-6

Unit: mm

Style	A	B	Note
FRC16, 20, 32	9 ^{+1.0} / ₀	11.4±1.0	Injection molding
		13±1.0	Vacuum forming

Note: Marking label shall be marked on a place of Marking A or two place of marking A and B.

9.4 Leader and trailer tape.

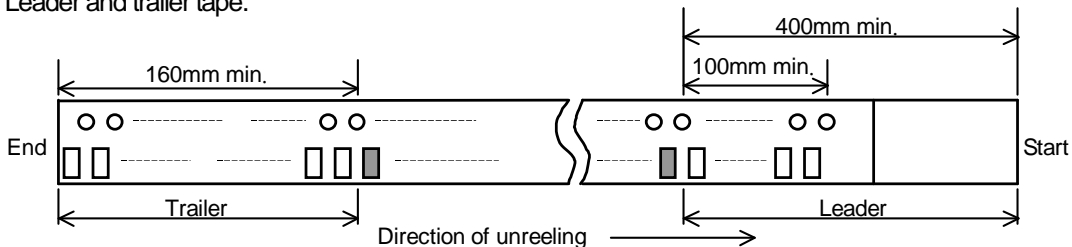

Figure-9

10. Marking on package

The label of a minimum package shall be legibly marked with follows.

10.1 Marking A

(1) Classification



(Style, Characteristics symbol, Rated dissipation Rated resistance, Tolerance on rated resistance, Packaging form)

(2) Quantity (3) Lot number (4) Manufacturer's name or trade mark (5) Others

10.2 Marking B(KAMAYA control label)

Looking for pricing, stock, or lifecycle information?

Click below to explore more details on WIN SOURCE:

-  [View FRC20C2A6R8JTP on WIN SOURCE](#)
-  [Kamaya Inc. Information](#)

Optimize Your Supply Chain with WIN SOURCE Solutions

-  Global Sourcing Solution
-  Obsolete Management
-  Cost Control Management
-  Shortage Management
-  Alternative Solution
-  Excess Inventory Management