

Motion SPM[®] 45 Series

FNA41560, FNA41560B2

General Description

FNA41560 / FNA41560B2 is a Motion SPM 45 module providing a fully-featured, high-performance inverter output stage for AC Induction, BLDC, and PMSM motors. These modules integrate optimized gate drive of the built-in IGBTs to minimize EMI and losses, while also providing multiple on-module protection features including under-voltage lockouts, over-current shutdown, thermal monitoring, and fault reporting. The built-in, highspeed HVIC requires only a single supply voltage and translates the incoming logic-level gate inputs to the high-voltage, high-current drive signals required to properly drive the module's robust short-circuit-rated IGBTs. Separate negative IGBT terminals are available for each phase to support the widest variety of control algorithms.

Features

- UL Certified No. E209204 (UL1557)
- 600 V – 15 A 3-Phase IGBT Inverter with Integral Gate Drivers and Protection
- Low Thermal Resistance Using Ceramic Substrate
- Low-Loss, Short-Circuit Rated IGBTs
- Built-In Bootstrap Diodes and Dedicated Vs Pins Simplify PCB Layout
- Built-In NTC Thermistor for Temperature Monitoring
- Separate Open-Emitter Pins from Low-Side IGBTs for Three-Phase Current Sensing
- Single-Grounded Power Supply
- Optimized for 5 kHz Switching Frequency
- Isolation Rating: 2000 V_{rms}/ min.

Applications

- Motion Control – Home Appliance / Industrial Motor

Related Resources

- [AN-9070 – Motion SPM[®] 45 Series Users Guide](#)
- [AN-9071 – Motion SPM[®] 45 Series Thermal Performance Information](#)
- [AN-9072 – Motion SPM[®] 45 Series Mounting Guidance](#)
- RD-344 – Reference Design (Three Shunt Solution)
- RD-345 – Reference Design (One Shunt Solution)

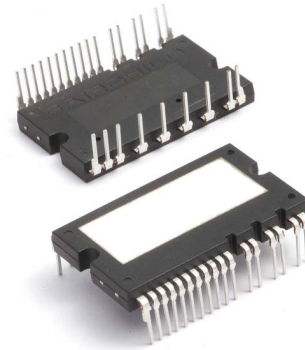

SPMAA-A26 / 26LD, PDD STD, CERAMIC TYPE,
STANDARD DUAL FORM
CASE MODFA

SPMAA-C26 / 26LD, PDD STD CERAMIC TYPE,
LONG LEAD DUAL FORM TYPE
CASE MODFC

MARKING DIAGRAM

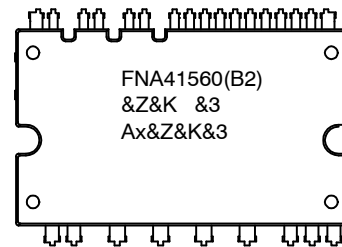

FNA41560(B2) = Specific Device Code
&Z = Assembly Plant Code
&K = Lot Code
&3 = Date Code (Year & Week)
Ax = Specific Product Name
x = D, M

ORDERING INFORMATION

Device	Package	Shipping
FNA41560	SPMAA-A26 (Pb-Free, Halide Free)	12 Units / Tube
FNA41560B2	SPMAA-C26 (Pb-Free, Halide Free)	12 Units / Tube

FNA41560, FNA41560B2

Integrated Power Function

- 600 V – 15 A IGBT Inverter for three-phase DC / AC power conversion (please refer to Figure 2)

Integrated Drive, Protection, and System Control Functions

- For Inverter High-side IGBTs: Gate Drive Circuit, High-voltage Isolated High-speed Level Shifting Control Circuit Under-Voltage Lock-Out (UVLO) Protection
- For Inverter Low-side IGBTs: Gate Drive Circuit, Short-Circuit Protection (SCP) Control Supply Circuit Under-Voltage Lock-Out (UVLO) Protection
- Fault Signaling: Corresponding to UVLO (Low-side Supply) and SC Faults
- Input Interface: Active-HIGH Interface, Works with 3.3 / 5 V Logic, Schmitt Trigger Input

PIN CONFIGURATION

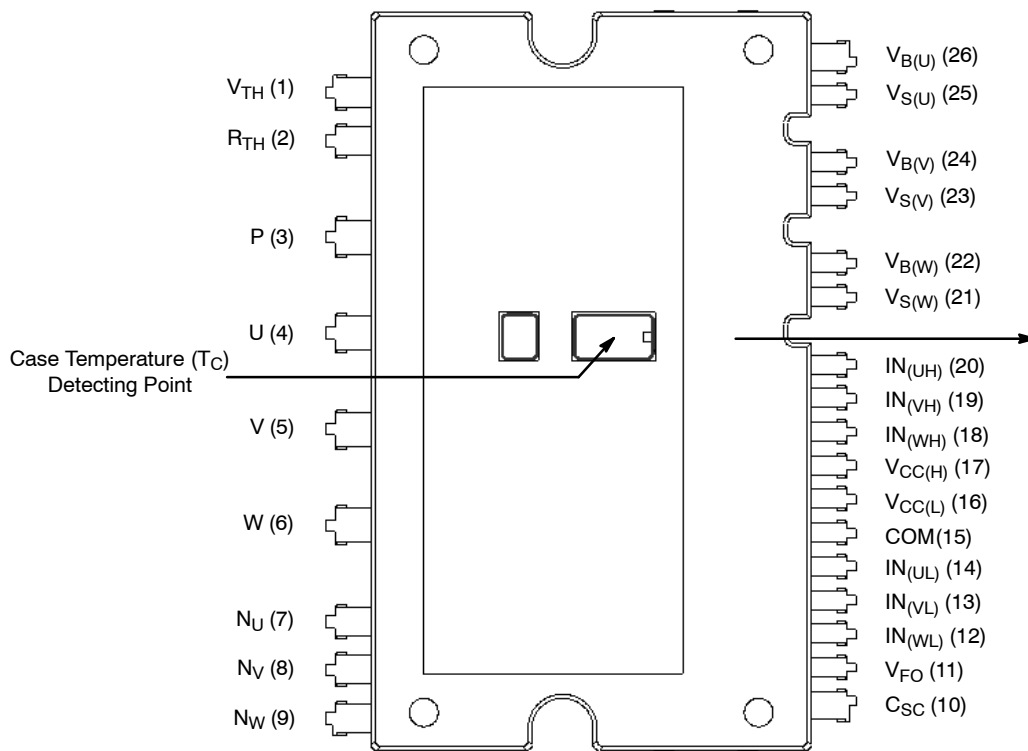

Figure 1. Top View

FNA41560, FNA41560B2

PIN DESCRIPTIONS

Pin No.	Pin Name	Pin Description
1	V_{TH}	Thermistor Bias Voltage
2	R_{TH}	Series Resistor for the Use of Thermistor (Temperature Detection)
3	P	Positive DC-Link Input
4	U	Output for U-Phase
5	V	Output for V-Phase
6	W	Output for W-Phase
7	N_U	Negative DC-Link Input for U-Phase
8	N_V	Negative DC-Link Input for V-Phase
9	N_W	Negative DC-Link Input for W-Phase
10	C_{SC}	Capacitor (Low-Pass Filter) for Short-circuit Current Detection Input
11	V_{FO}	Fault Output
12	$IN_{(WL)}$	Signal Input for Low-Side W-Phase
13	$IN_{(VL)}$	Signal Input for Low-Side V-Phase
14	$IN_{(UL)}$	Signal Input for Low-Side U-Phase
15	COM	Common Supply Ground
16	$V_{CC(L)}$	Low-Side Common Bias Voltage for IC and IGBTs Driving
17	$V_{CC(H)}$	High-Side Common Bias Voltage for IC and IGBTs Driving
18	$IN_{(WH)}$	Signal Input for High-Side W-Phase
19	$IN_{(VH)}$	Signal Input for High-Side V-Phase
20	$IN_{(UH)}$	Signal Input for High-Side U-Phase
21	$V_{S(W)}$	High-Side Bias Voltage Ground for W-Phase IGBT Driving
22	$V_{B(W)}$	High-Side Bias Voltage for W-Phase IGBT Driving
23	$V_{S(V)}$	High-Side Bias Voltage Ground for V-Phase IGBT Driving
24	$V_{B(V)}$	High-Side Bias Voltage for V-Phase IGBT Driving
25	$V_{S(U)}$	High-Side Bias Voltage Ground for U-Phase IGBT Driving
26	$V_{B(U)}$	High-Side Bias Voltage for U-Phase IGBT Driving

FNA41560, FNA41560B2

Internal Equivalent Circuit and Input/Output Pins

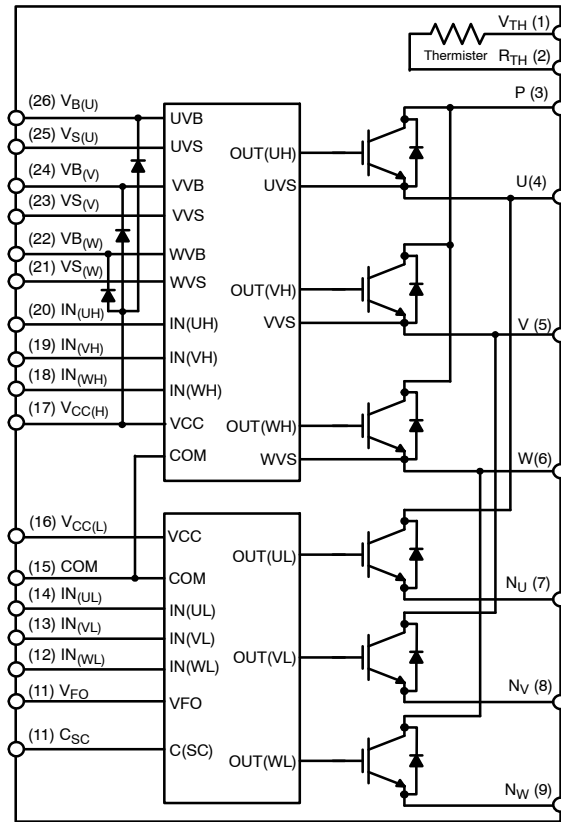

NOTES:

1. Inverter high-side is composed of three IGBTs, freewheeling diodes, and one control IC for each IGBT.
2. Inverter low-side is composed of three IGBTs, freewheeling diodes, and one control IC for each IGBT. It has gate drive and protection functions.
3. Inverter power side is composed of four inverter DC-link input terminals and three inverter output terminals.

Figure 2. Internal Block Diagram

FNA41560, FNA41560B2

ABSOLUTE MAXIMUM RATINGS (T_J = 25°C unless otherwise specified)

Symbol	Parameter	Conditions	Rating	Unit
INVERTER PART				
V _{PN}	Output Voltage	Applied between P – N _U , N _V , N _W	450	V
V _{PN(Surge)}	Output Voltage (Surge)	Applied between P – N _U , N _V , N _W	500	V
V _{CES}	Collector – Emitter Voltage		600	V
±I _C	Each IGBT Collector Current	T _C = 25°C, T _J < 150°C	15	A
±I _{CP}	Each IGBT Collector Current (Peak)	T _C = 25°C, T _J < 150°C, Under 1 ms Pulse Width	30	A
P _C	Collector Dissipation	T _C = 25°C per Chip	41	W
T _J	Operating Junction Temperature	(Note 4)	-40 ~ 150	°C

CONTROL PART

V _{CC}	Control Supply Voltage	Applied between V _{CC(H)} , V _{CC(L)} – COM	20	V
V _{BS}	High – Side Control Bias Voltage	Applied between V _{B(U)} – V _{S(U)} , V _{B(V)} – V _{S(V)} , V _{B(W)} – V _{S(W)}	20	V
V _{IN}	Input Signal Voltage	Applied between IN _(UH) , IN _(VH) , IN _(WH) , IN _(UL) , IN _(VL) , IN _(WL) – COM	-0.3 ~ V _{CC} + 0.3	V
V _{FO}	Fault Output Supply Voltage	Applied between V _{FO} – COM	-0.3 ~ V _{CC} + 0.3	V
I _{FO}	Fault Output Current	Sink Current at V _{FO} pin	1	mA
V _{SC}	Current–Sensing Input Voltage	Applied between C _{SC} – COM	-0.3 ~ V _{CC} + 0.3	V

BOOTSTRAP DIODE PART

V _{RRM}	Maximum Repetitive Reverse Voltage		600	V
I _F	Forward Current	T _C = 25°C, T _J < 150°C	0.50	A
I _{FP}	Forward Current (Peak)	T _C = 25°C, T _J < 150°C, Under 1 ms Pulse Width	1.50	A
T _J	Operating Junction Temperature		-40 ~ 150	°C

TOTAL SYSTEM

V _{PN(PROT)}	Self–Protection Supply Voltage Limit (Short–Circuit Protection Capability)	V _{CC} = V _{BS} = 13.5 ~ 16.5 V T _J = 150°C, Non–Repetitive, < 2 μs	400	V
T _{STG}	Storage Temperature		-40 ~ 125	°C
V _{ISO}	Isolation Voltage	60 Hz, Sinusoidal, AC 1 Minute, Connect Pins to Heat Sink Plate	2000	V _{rms}

Stresses exceeding those listed in the Maximum Ratings table may damage the device. If any of these limits are exceeded, device functionality should not be assumed, damage may occur and reliability may be affected.

4. The maximum junction temperature rating of the power chips integrated within the Motion SPM 45 product is 150°C.

THERMAL RESISTANCE

Symbol	Parameter	Conditions	Min	Typ	Max	Unit
R _{th(j-c)Q}	Junction to Case Thermal Resistance	Inverter IGBT Part (per 1/6 module)	–	–	3.0	°C/W
R _{th(j-c)F}		Inverter FWDi Part (per 1/6 module)	–	–	4.3	°C/W

5. For the measurement point of case temperature (T_C), please refer to Figure 1.

FNA41560, FNA41560B2

ELECTRICAL CHARACTERISTICS ($T_J = 25^\circ\text{C}$ unless otherwise specified.)

Symbol	Parameter	Conditions	Min	Typ	Max	Unit	
INVERTER PART							
$V_{CE(SAT)}$	Collector – Emitter Saturation Voltage	$V_{CC} = V_{BS} = 15\text{ V}$ $V_{IN} = 5\text{ V}$	$I_C = 50\text{ A}$, $T_J = 25^\circ\text{C}$	–	1.8	2.3	V
V_F	FWDi Forward Voltage	$V_{IN} = 0\text{ V}$	$I_F = 50\text{ A}$, $T_J = 25^\circ\text{C}$	–	1.8	2.3	V
HS	t_{ON}	Switching Times	$V_{PN} = 300\text{ V}$, $V_{CC} = V_{BS} = 15\text{ V}$, $I_C = 15\text{ A}$, $T_J = 25^\circ\text{C}$ $V_{IN} = 0\text{ V} \leftrightarrow 5\text{ V}$, Inductive load (Note 6)	0.45	0.75	1.25	μs
	$t_{C(ON)}$			–	0.25	0.50	μs
	t_{OFF}			–	0.75	1.25	μs
	$t_{C(OFF)}$			–	0.25	0.50	μs
	t_{rr}			–	0.15	–	μs
LS	t_{ON}	Switching Times	$V_{PN} = 300\text{ V}$, $V_{CC} = V_{BS} = 15\text{ V}$, $I_C = 15\text{ A}$, $T_J = 25^\circ\text{C}$ $V_{IN} = 0\text{ V} \leftrightarrow 5\text{ V}$, Inductive load (Note 6)	0.45	0.75	1.25	μs
	$t_{C(ON)}$			–	0.25	0.50	μs
	t_{OFF}			–	0.75	1.25	μs
	$t_{C(OFF)}$			–	0.25	0.50	μs
	t_{rr}			–	0.15	–	μs
I_{CES}	Collector – Emitter Leakage Current	$V_{CE} = V_{CES}$	–	–	1	mA	

Product parametric performance is indicated in the Electrical Characteristics for the listed test conditions, unless otherwise noted. Product performance may not be indicated by the Electrical Characteristics if operated under different conditions.

6. t_{ON} and t_{OFF} include the propagation delay of the internal drive IC. $t_{C(ON)}$ and $t_{C(OFF)}$ are the switching times of IGBT itself under the given gate driving condition internally. For the detailed information, please see Figure 3.

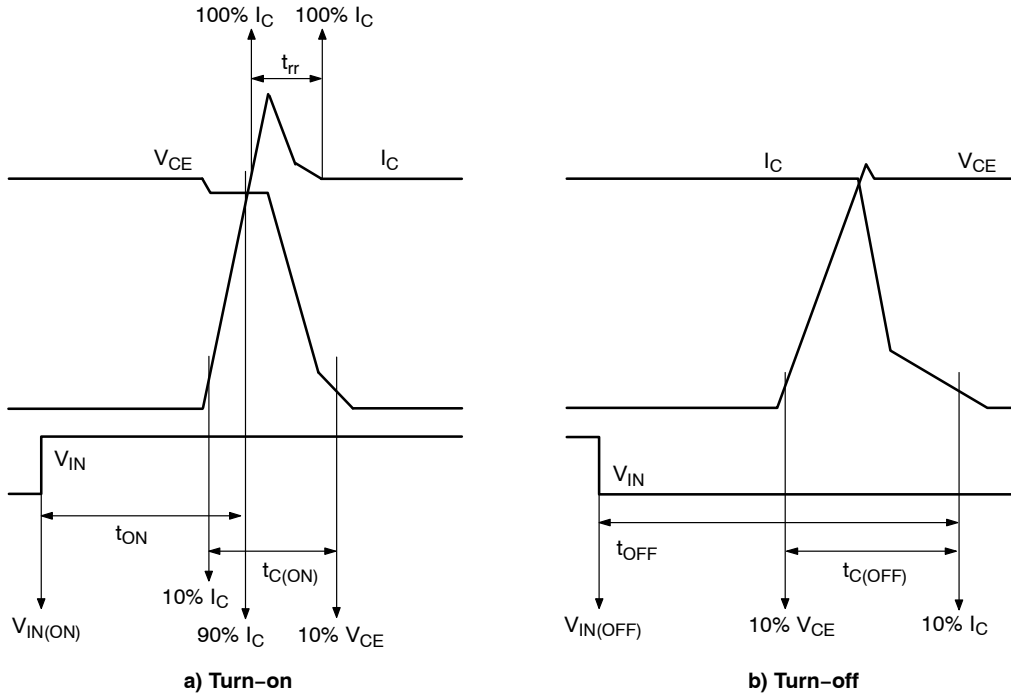
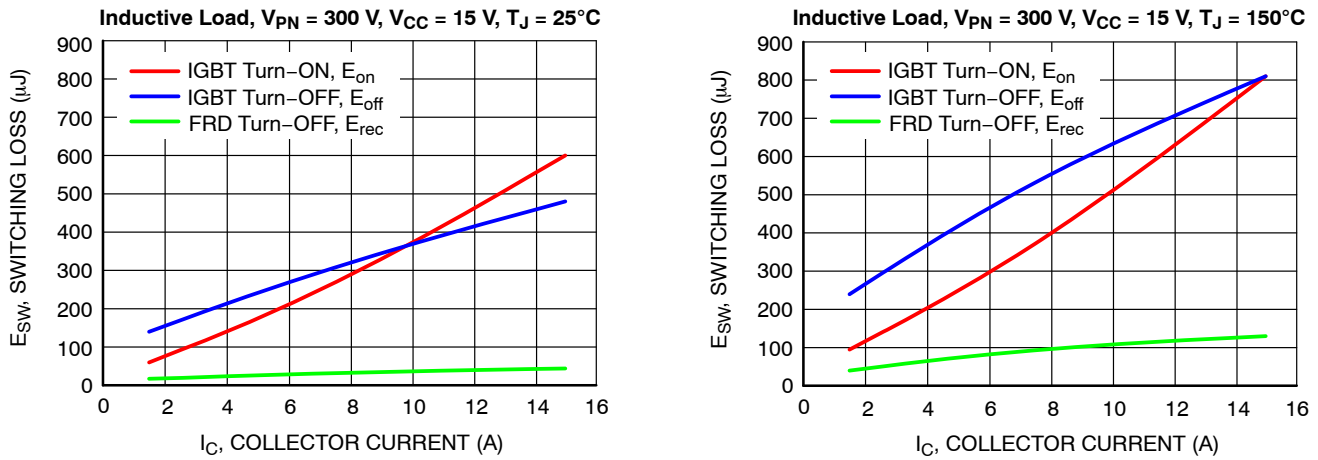

Figure 3. Switching Time Definition

FNA41560, FNA41560B2



ELECTRICAL CHARACTERISTICS ($T_J = 25^\circ\text{C}$ unless otherwise specified.) (continued)

Symbol	Parameter	Conditions	Min	Typ	Max	Unit	
CONTROL PART							
I_{QCCH}	Quiescent V_{CC} Supply Current	$V_{CC(H)} = 15\text{ V}$, $I_{N(UH, VH, WH)} = 0\text{ V}$	$V_{CC(H)} - \text{COM}$	-	-	0.10	mA
I_{QCCL}		$V_{CC(L)} = 15\text{ V}$, $I_{N(UL, VL, WL)} = 0\text{ V}$	$V_{CC(L)} - \text{COM}$	-	-	2.65	mA
I_{PCCH}	Operating V_{CC} Supply Current	$V_{CC(L)} = 15\text{ V}$, $f_{PWM} = 20\text{ kHz}$, duty = 50%, Applied to One PWM Signal Input for High-Side	$V_{CC(H)} - \text{COM}$	-	-	0.15	mA
I_{PCCL}		$V_{CC(L)} = 15\text{ V}$, $f_{PWM} = 20\text{ kHz}$, duty = 50%, Applied to One PWM Signal Input for Low-Side	$V_{CC(L)} - \text{COM}$	-	-	3.65	mA
I_{QBS}	Quiescent V_{BS} Supply Current	$V_{BS} = 15\text{ V}$, $I_{N(UH, VH, WH)} = 0\text{ V}$	$V_{B(U)} - V_{S(U)}$, $V_{B(V)} - V_{S(V)}$, $V_{B(W)} - V_{S(W)}$	-	-	0.30	mA
I_{PBS}	Operating V_{BS} Supply Current	$V_{CC} = V_{BS} = 15\text{ V}$, $f_{PWM} = 20\text{ kHz}$, duty = 50%, Applied to One PWM Signal Input for High-Side	$V_{B(U)} - V_{S(U)}$, $V_{B(V)} - V_{S(V)}$, $V_{B(W)} - V_{S(W)}$	-	-	2.00	mA
V_{FOH}	Fault Output Voltage	$V_{SC} = 0\text{ V}$, V_{FO} Circuit: 10 k Ω to 5 V Pull-up	4.5	-	-	V	
V_{FOL}		$V_{SC} = 1\text{ V}$, V_{FO} Circuit: 10 k Ω to 5 V Pull-up	-	-	0.5	V	
$V_{SC(ref)}$	Short-Circuit Current Trip Level	$V_{CC} = 15\text{ V}$ (Note 7)	0.45	0.50	0.55	V	
UV_{CCD}	Supply Circuit Under-Voltage Protection	Detection level	10.5	-	13.0	V	
UV_{CCR}		Reset level	11.0	-	13.5	V	
UV_{BSD}		Detection level	10.0	-	12.5	V	
UV_{BSR}		Reset level	10.5	-	13.0	V	
t_{FOD}	Fault-Out Pulse Width		30	-	-	μs	
$V_{IN(ON)}$	ON Threshold Voltage	Applied between $I_{N(UH)}$, $I_{N(VH)}$, $I_{N(WH)}$, $I_{N(UL)}$, $I_{N(VL)}$, $I_{N(WL)} - \text{COM}$	-	-	2.6	V	
$V_{IN(OFF)}$	OFF Threshold Voltage		0.8	-	-	V	
R_{TH}	Resistance of Thermistor	@ $T_{TH} = 25^\circ\text{C}$ (Note 8)	-	47	-	k Ω	
		@ $T_{TH} = 100^\circ\text{C}$	-	2.9	-	k Ω	

Product parametric performance is indicated in the Electrical Characteristics for the listed test conditions, unless otherwise noted. Product performance may not be indicated by the Electrical Characteristics if operated under different conditions.

7. Short-circuit protection is functioning only at the low-sides.

8. T_{TH} is the temperature of thermister itself. To know case temperature (T_C), please make the experiment considering your application.

FNA41560, FNA41560B2

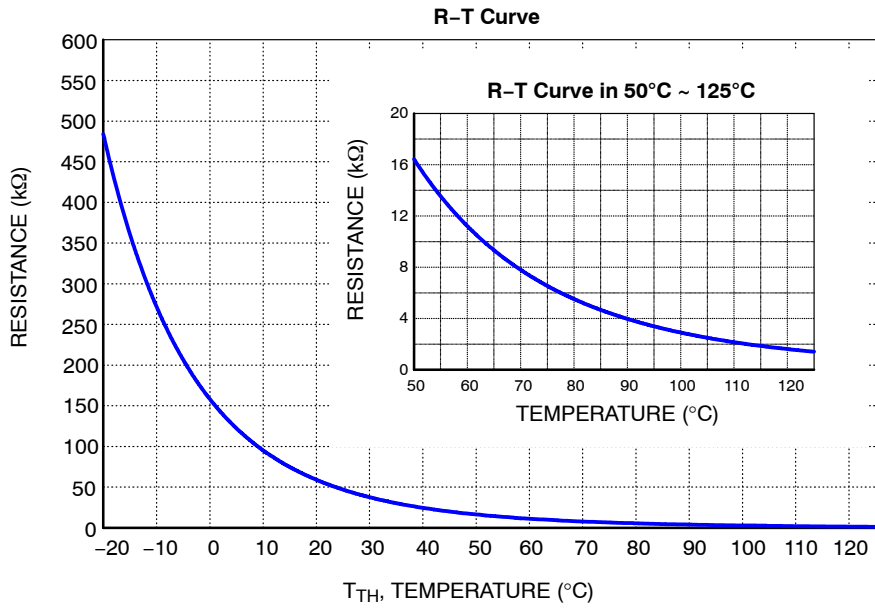
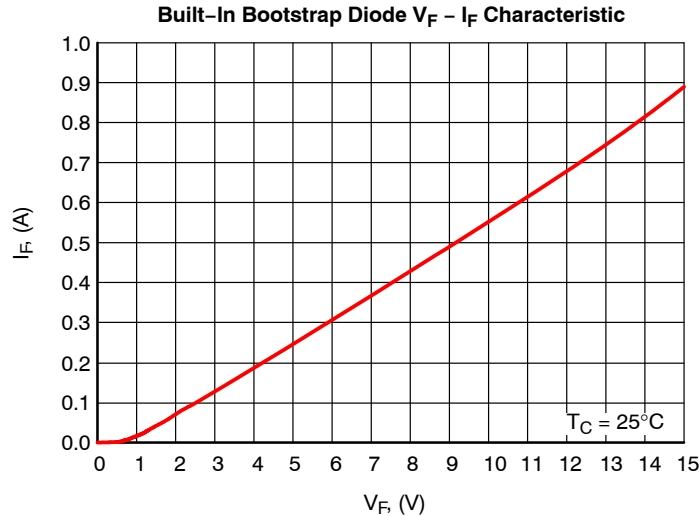

Figure 5. R-T Curve of The Built-In Thermistor

ELECTRICAL CHARACTERISTICS ($T_J = 25^\circ\text{C}$ unless otherwise specified.) (continued)

Symbol	Parameter	Conditions	Min	Typ	Max	Unit
BOOTSTRAP DIODE PART						
V_F	Forward Voltage	$I_F = 0.1\text{ A}$, $T_C = 25^\circ\text{C}$	–	2.5	–	V
t_{rr}	Reverse-Recovery Time	$I_F = 0.1\text{ A}$, $T_C = 25^\circ\text{C}$	–	80	–	ns

Product parametric performance is indicated in the Electrical Characteristics for the listed test conditions, unless otherwise noted. Product performance may not be indicated by the Electrical Characteristics if operated under different conditions.



NOTE:

9. Built-in bootstrap diode includes around 15 Ω resistance characteristic.

Figure 6. Built-In Bootstrap Diode Characteristic

FNA41560, FNA41560B2

RECOMMENDED OPERATING CONDITIONS

Symbol	Parameter	Conditions	Min	Typ	Max	Unit
V_{PN}	Supply Voltage	Applied between P – N_U , N_V , N_W	–	300	400	V
V_{CC}	Control Supply Voltage	Applied between $V_{CC(H)}$, $V_{CC(L)}$ – COM	13.5	15.0	16.5	V
V_{BS}	High-Side Bias Voltage	Applied between $V_{B(U)} - V_{S(U)}$, $V_{B(V)} - V_{S(V)}$, $V_{B(W)} - V_{S(W)}$	13.0	15.0	18.5	V
dV_{CC}/dt , dV_{BS}/dt	Control Supply Variation		–1	–	1	V/ μ s
t_{dead}	Blanking Time for Preventing Arm-Short	For each input signal	1.5	–	–	μ s
f_{PWM}	PWM Input Signal	$-40^\circ\text{C} < T_J < 150^\circ\text{C}$	–	–	20	kHz
V_{SEN}	Voltage for Current Sensing	Applied between N_U , N_V , N_W – COM (Including Surge-Voltage)	–4	–	4	V
$P_{WIN(ON)}$	Minimum Input Pulse Width	(Note 10)	0.5	–	–	μ s
$P_{WIN(OFF)}$			0.5	–	–	

Functional operation above the stresses listed in the Recommended Operating Ranges is not implied. Extended exposure to stresses beyond the Recommended Operating Ranges limits may affect device reliability.

10. This product might not make response if input pulse width is less than the recommended value.

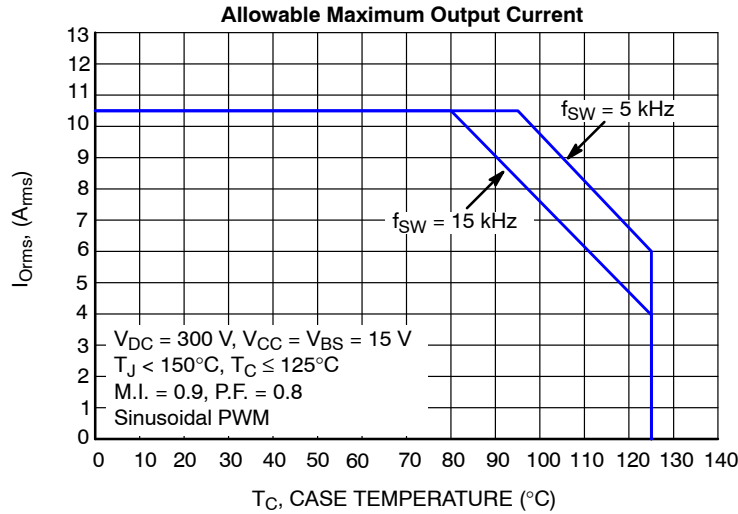

NOTE:

11. This allowable output current value is the reference data for the safe operation of this product. This may be different from the actual application and operating condition.

Figure 7. Allowable Maximum Output Current

FNA41560, FNA41560B2

MECHANICAL CHARACTERISTICS AND RATINGS

Parameter	Conditions	Min	Typ	Max	Unit	
Device Flatness	See Figure 8	0	-	+120	μm	
Mounting Torque	Mounting Screw: M3 See Figure 9	Recommended 0.7 N • m	0.6	0.7	0.8	N • m
		Recommended 7.1 kg • cm	6.2	7.1	8.1	kg • cm
Weight		-	11.00	-	g	

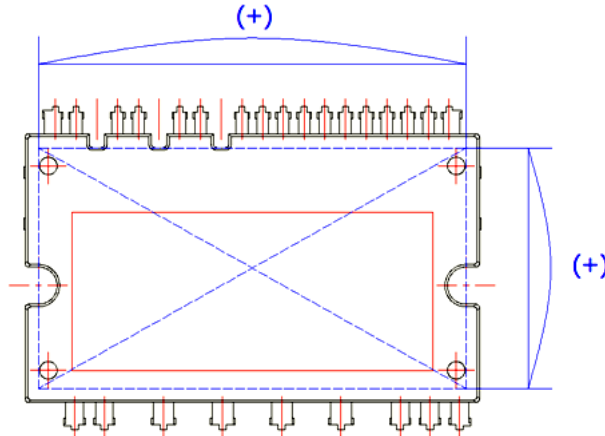
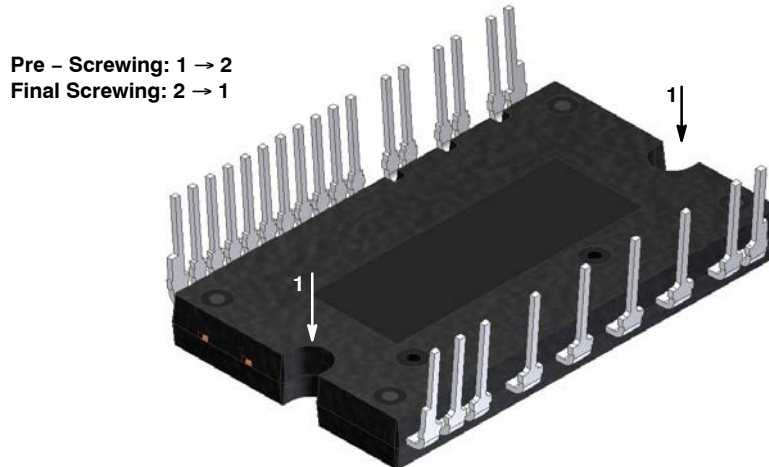

Figure 8. Flatness Measurement Position



NOTES:

12. Do not make over torque when mounting screws. Much mounting torque may cause ceramic cracks, as well as bolts and Al heat-sink destruction.
13. Avoid one side tightening stress. Figure 9 shows the recommended torque order for mounting screws. Uneven mounting can cause the ceramic substrate of the SPM 45 package to be damaged. The pre-screwing torque is set to 20 ~ 30% of maximum torque rating.

Figure 9. Mounting Screws Torque Order

TIME CHARTS OF PROTECTIVE FUNCTION

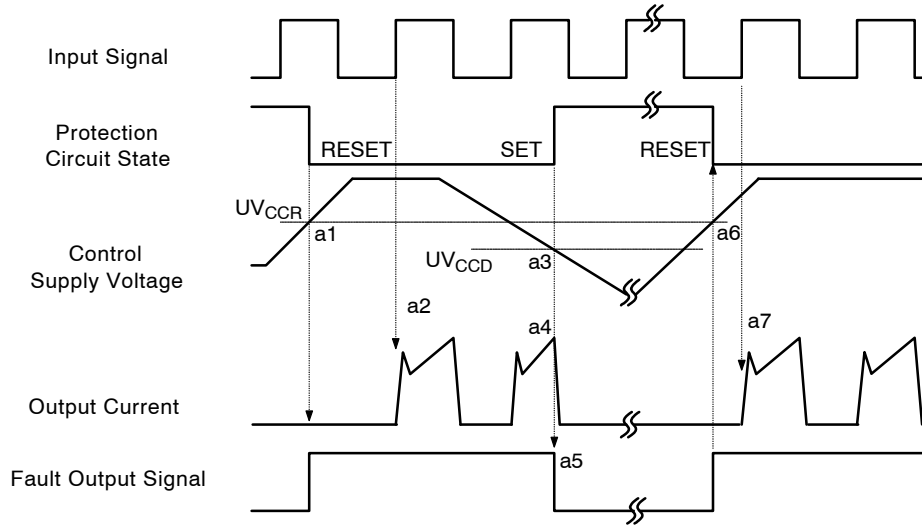

- a1: Control supply voltage rises: after the voltage rises UV_{CCR} , the circuits start to operate when next input is applied.
- a2: Normal operation: IGBT ON and carrying current.
- a3: Under-voltage detection (UV_{CCD}).
- a4: IGBT OFF in spite of control input condition.
- a5: Fault output operation starts.
- a6: Under-voltage reset (UV_{CCR}).
- a7: Normal operation: IGBT ON and carrying current.

Figure 10. Under-Voltage Protection (Low-Side)

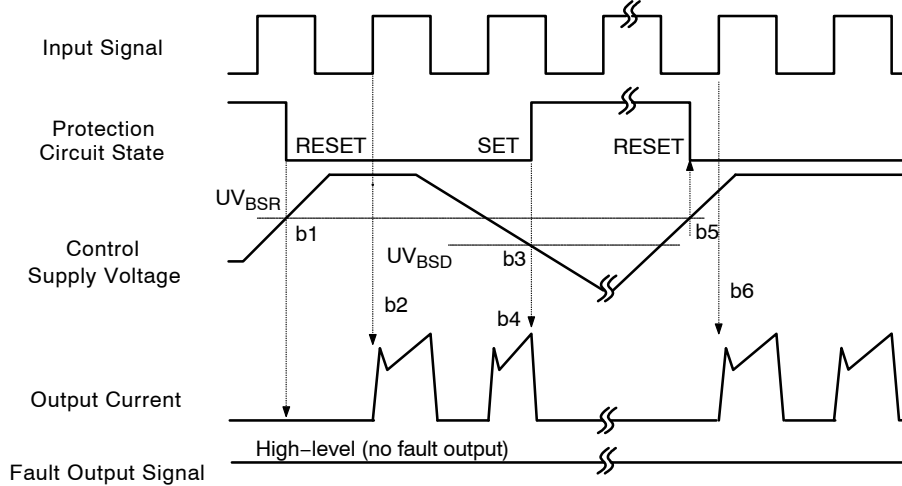

- b1: Control supply voltage rises: after the voltage reaches UV_{BSR} , the circuits start to operate when next input is applied.
- b2: Normal operation: IGBT ON and carrying current.
- b3: Under-voltage detection (UV_{BSD}).
- b4: IGBT OFF in spite of control input condition, but there is no fault output signal.
- b5: Under-voltage reset (UV_{BSR}).
- b6: Normal operation: IGBT ON and carrying current.

Figure 11. Under-Voltage Protection (High-Side)

FNA41560, FNA41560B2

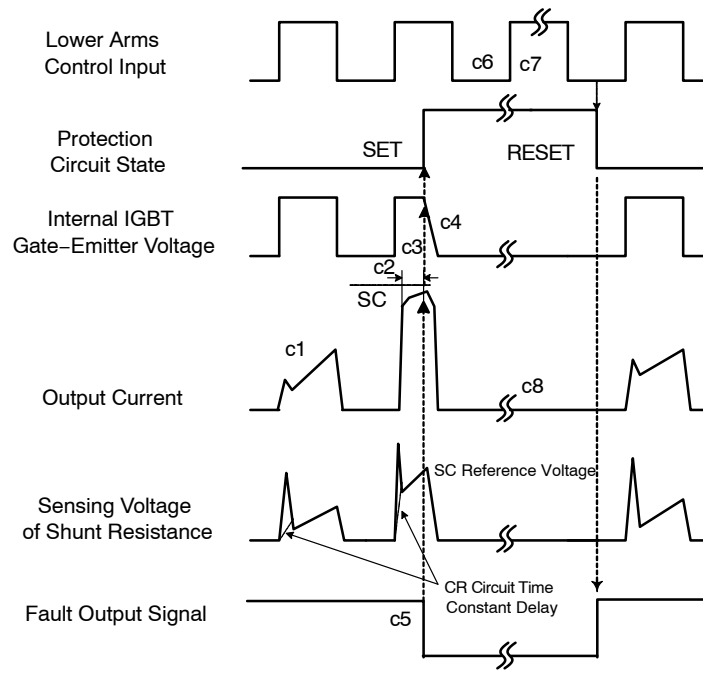

(with the external shunt resistance and CR connection)

c1: Normal operation: IGBT ON and carrying current.

c2: Short-circuit current detection (SC trigger).

c3: Hard IGBT gate interrupt.

c4: IGBT turns OFF.

c5: Input "LOW": IGBT OFF state.

c6: Input "HIGH": IGBT ON state, but during the active period of fault output, the IGBT doesn't turn ON.

c7: IGBT OFF state.

Figure 12. Short-Circuit Protection (Low-Side Operation Only)

INPUT/OUTPUT INTERFACE CIRCUIT

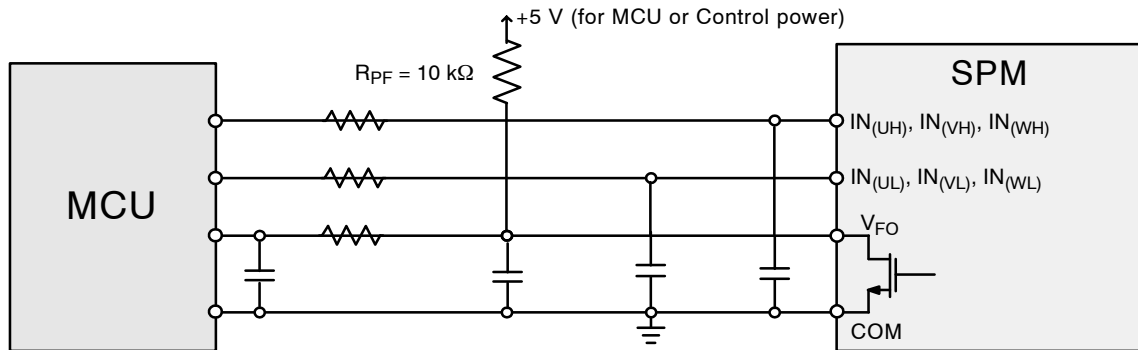

NOTE:

14. RC coupling at each input (parts shown dotted) might change depending on the PWM control scheme in the application and the wiring impedance of the application's printed circuit board. The input signal section of the Motion SPM 45 product integrates a 5 kΩ (typ.) pull-down resistor. Therefore, when using an external filtering resistor, pay attention to the signal voltage drop at input terminal.

Figure 13. Recommended MCU I/O Interface Circuit

MECHANICAL CASE OUTLINE

PACKAGE DIMENSIONS

ON Semiconductor®



SPMAA-A26 / 26LD, PDD STD, CERAMIC TYPE, STANDARD DUAL FORM

CASE MODFA

ISSUE O

DATE 31 JAN 2017

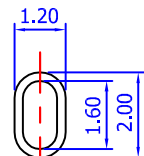
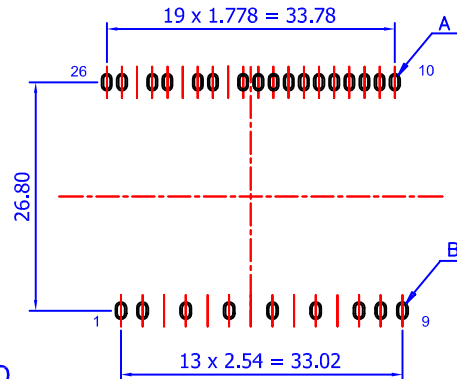
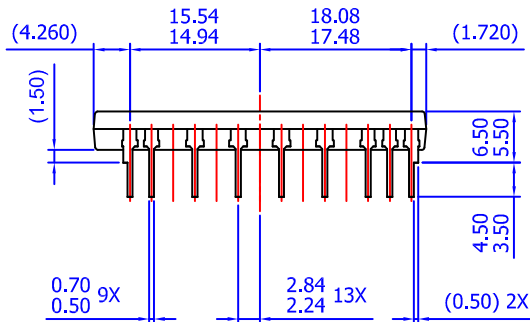
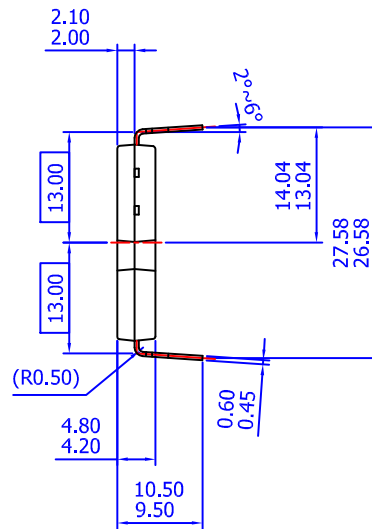
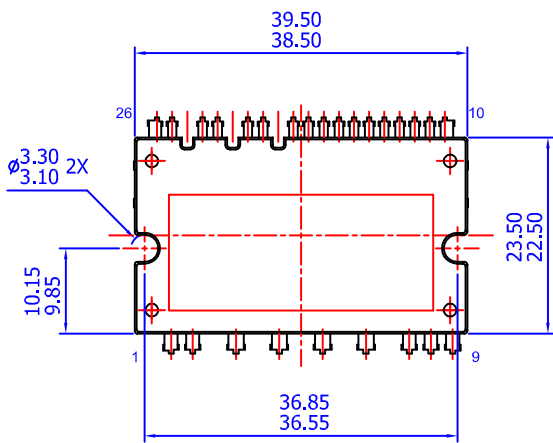
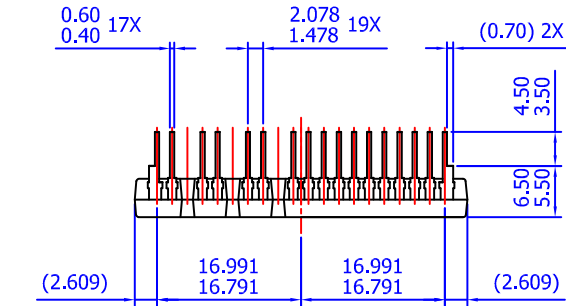

DETAIL A
(SCALE N/A)

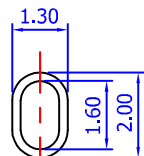

DETAIL B
(SCALE N/A)

- NOTES: UNLESS OTHERWISE SPECIFIED
- A) THIS PACKAGE DOES NOT COMPLY TO ANY CURRENT PACKAGING STANDARD
 - B) ALL DIMENSIONS ARE IN MILLIMETERS
 - C) DIMENSIONS ARE EXCLUSIVE OF BURRS, MOLD FLASH, AND TIE BAR EXTRUSIONS
 - D) () IS REFERENCE

LAND PATTERN RECOMMENDATIONS

DOCUMENT NUMBER:	98AON13553G	Electronic versions are uncontrolled except when accessed directly from the Document Repository. Printed versions are uncontrolled except when stamped "CONTROLLED COPY" in red.
DESCRIPTION:	SPMAA-A26 / 26LD, PDD STD, CERAMIC TYPE, STANDARD DUAL	PAGE 1 OF 1

ON Semiconductor and are trademarks of Semiconductor Components Industries, LLC dba ON Semiconductor or its subsidiaries in the United States and/or other countries. ON Semiconductor reserves the right to make changes without further notice to any products herein. ON Semiconductor makes no warranty, representation or guarantee regarding the suitability of its products for any particular purpose, nor does ON Semiconductor assume any liability arising out of the application or use of any product or circuit, and specifically disclaims any and all liability, including without limitation special, consequential or incidental damages. ON Semiconductor does not convey any license under its patent rights nor the rights of others.

MECHANICAL CASE OUTLINE PACKAGE DIMENSIONS

ON Semiconductor®



SPMAA-C26 / 26LD, PDD STD CERAMIC TYPE, LONG LEAD DUAL FORM TYPE CASE MODFC ISSUE O

DATE 31 JAN 2017

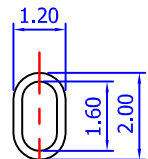
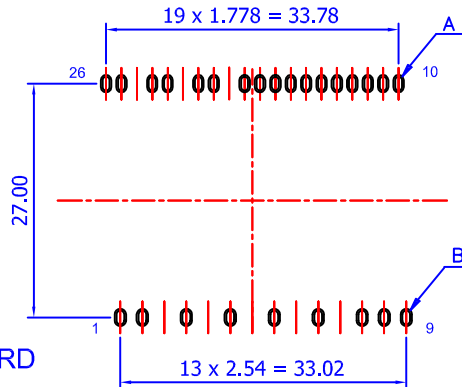
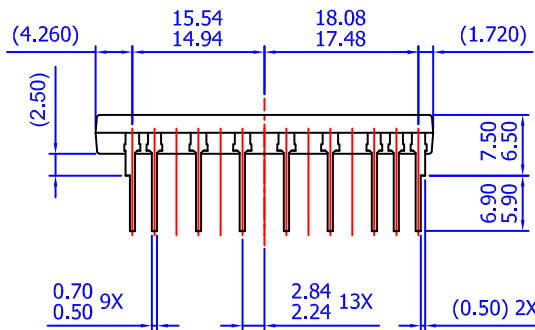
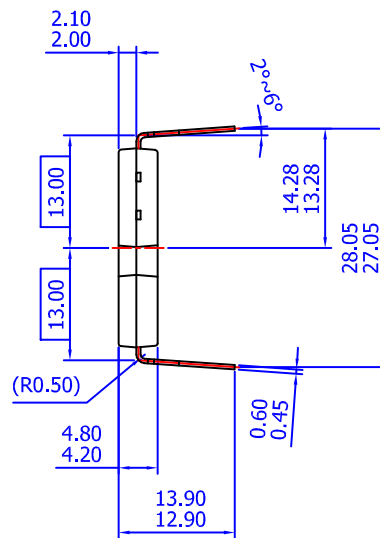
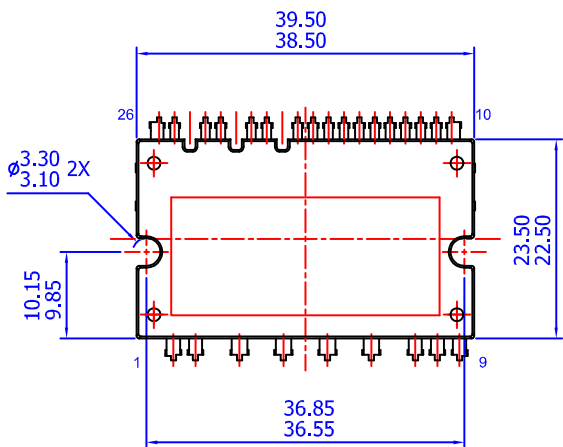
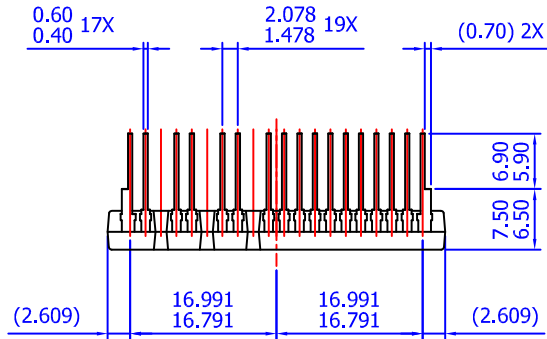

DETAIL A
(SCALE N/A)

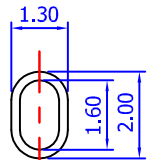

DETAIL B
(SCALE N/A)

- NOTES: UNLESS OTHERWISE SPECIFIED
 A) THIS PACKAGE DOES NOT COMPLY TO ANY CURRENT PACKAGING STANDARD
 B) ALL DIMENSIONS ARE IN MILLIMETERS
 C) DIMENSIONS ARE EXCLUSIVE OF BURRS, MOLD FLASH, AND TIE BAR EXTRUSIONS
 D) () IS REFERENCE

LAND PATTERN RECOMMENDATIONS

DOCUMENT NUMBER:	98AON13555G	Electronic versions are uncontrolled except when accessed directly from the Document Repository. Printed versions are uncontrolled except when stamped "CONTROLLED COPY" in red.
DESCRIPTION:	SPMAA-C26 / 26LD, PDD STD CERAMIC TYPE, LONG LEAD DUAL	PAGE 1 OF 1

ON Semiconductor and ON are trademarks of Semiconductor Components Industries, LLC dba ON Semiconductor or its subsidiaries in the United States and/or other countries. ON Semiconductor reserves the right to make changes without further notice to any products herein. ON Semiconductor makes no warranty, representation or guarantee regarding the suitability of its products for any particular purpose, nor does ON Semiconductor assume any liability arising out of the application or use of any product or circuit, and specifically disclaims any and all liability, including without limitation special, consequential or incidental damages. ON Semiconductor does not convey any license under its patent rights nor the rights of others.

onsemi, **Onsemi**, and other names, marks, and brands are registered and/or common law trademarks of Semiconductor Components Industries, LLC dba "**onsemi**" or its affiliates and/or subsidiaries in the United States and/or other countries. **onsemi** owns the rights to a number of patents, trademarks, copyrights, trade secrets, and other intellectual property. A listing of **onsemi**'s product/patent coverage may be accessed at www.onsemi.com/site/pdf/Patent-Marking.pdf. **onsemi** reserves the right to make changes at any time to any products or information herein, without notice. The information herein is provided "as-is" and **onsemi** makes no warranty, representation or guarantee regarding the accuracy of the information, product features, availability, functionality, or suitability of its products for any particular purpose, nor does **onsemi** assume any liability arising out of the application or use of any product or circuit, and specifically disclaims any and all liability, including without limitation special, consequential or incidental damages. Buyer is responsible for its products and applications using **onsemi** products, including compliance with all laws, regulations and safety requirements or standards, regardless of any support or applications information provided by **onsemi**. "Typical" parameters which may be provided in **onsemi** data sheets and/or specifications can and do vary in different applications and actual performance may vary over time. All operating parameters, including "Typicals" must be validated for each customer application by customer's technical experts. **onsemi** does not convey any license under any of its intellectual property rights nor the rights of others. **onsemi** products are not designed, intended, or authorized for use as a critical component in life support systems or any FDA Class 3 medical devices or medical devices with a same or similar classification in a foreign jurisdiction or any devices intended for implantation in the human body. Should Buyer purchase or use **onsemi** products for any such unintended or unauthorized application, Buyer shall indemnify and hold **onsemi** and its officers, employees, subsidiaries, affiliates, and distributors harmless against all claims, costs, damages, and expenses, and reasonable attorney fees arising out of, directly or indirectly, any claim of personal injury or death associated with such unintended or unauthorized use, even if such claim alleges that **onsemi** was negligent regarding the design or manufacture of the part. **onsemi** is an Equal Opportunity/Affirmative Action Employer. This literature is subject to all applicable copyright laws and is not for resale in any manner.

ADDITIONAL INFORMATION

TECHNICAL PUBLICATIONS:

Technical Library: www.onsemi.com/design/resources/technical-documentation
onsemi Website: www.onsemi.com



ONLINE SUPPORT: www.onsemi.com/support

For additional information, please contact your local Sales Representative at www.onsemi.com/support/sales



Looking for pricing, stock, or lifecycle information?

Click below to explore more details on WIN SOURCE:

-  [View FNA41560B2 on WIN SOURCE](#)
-  [Fairchild/ON Semiconductor Information](#)

Optimize Your Supply Chain with WIN SOURCE Solutions

-  Global Sourcing Solution
-  Obsolete Management
-  Cost Control Management
-  Shortage Management
-  Alternative Solution
-  Excess Inventory Management