



# THE DATASHEET OF FL1000



# BONKOTE AMERICA







## Flux Dispensing Pens

These new handy Bon Pens allow for very accurate flux dispensing on the work area, while eliminating dripping and flooding. You have total control at your finger tips, unlike all of the messy dispensing bottles on the market. Made in Japan.

Very easily cleaned and maintained with alcohol or water, depending on Flux use.

- Re-usable flux applicator
- Replaceable tips & cartridge
- Low cost, 7CC capacity
- Fine point or broad point
- Flexible shafts
- Controlled application / no mess
- Used with non-wash, wash or strong acid flux
- Excellent for spot soldering on IC chips
- All units sold in 5 packs



-  BR-102
-  BR-102S
-  BR-102B
-  BR-102F
-  BR-102D
-  BR-102K
-  BR-102T

Replacement Tips

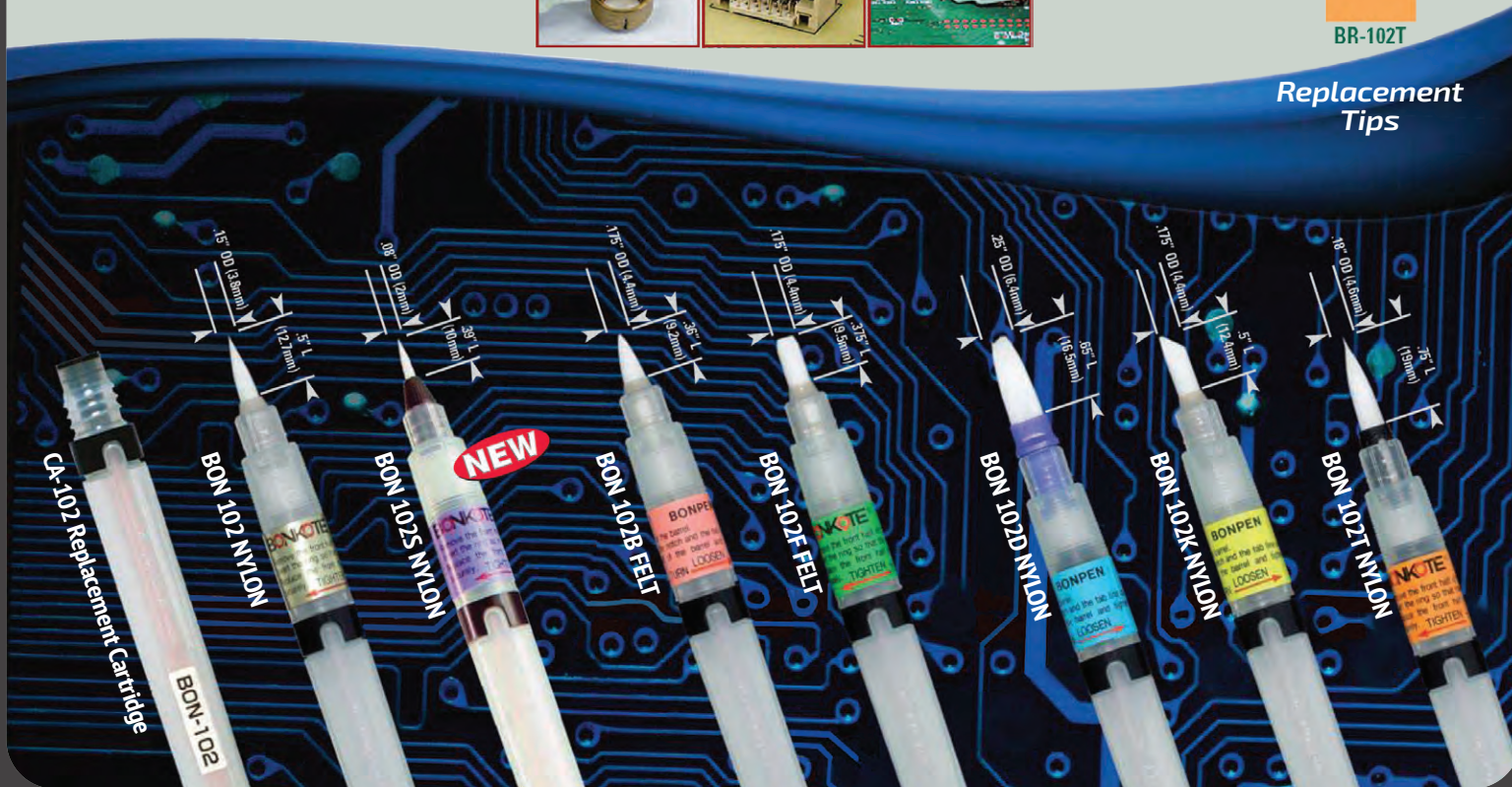

O.C. White Co.

See the Complete Lineup at [www.ocwhite.com](http://www.ocwhite.com)

Distributed By:



or Call: 413-289-1751 for a Representative Near You

OCWMAINCAT-0916

American Designed, American Craftsmanship

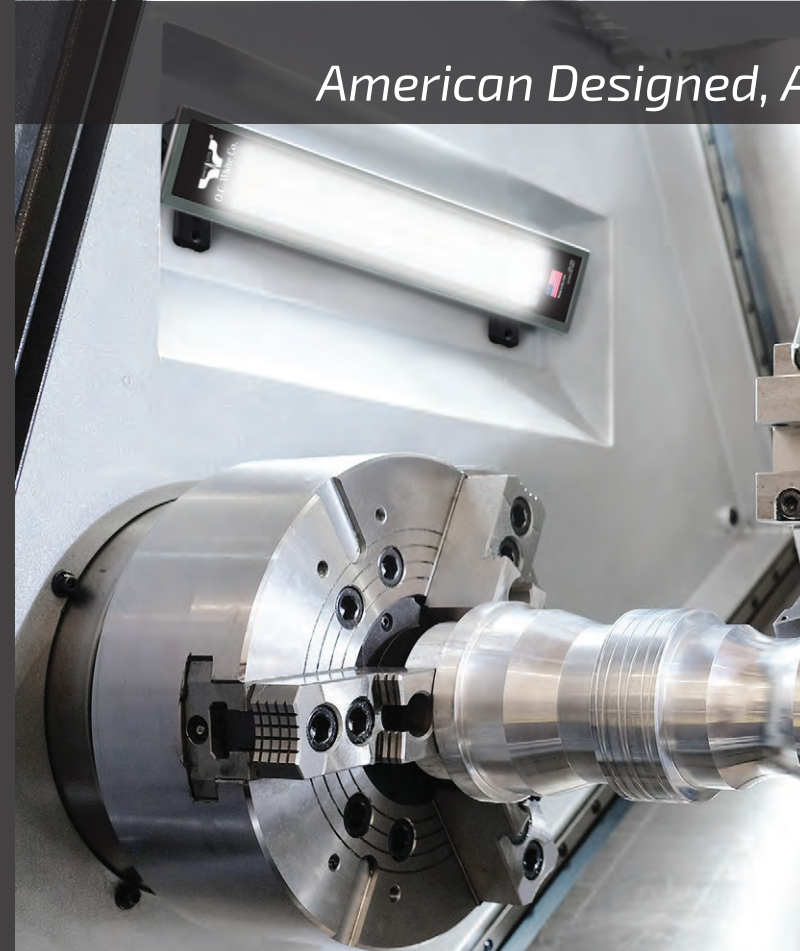

O.C. White Co.

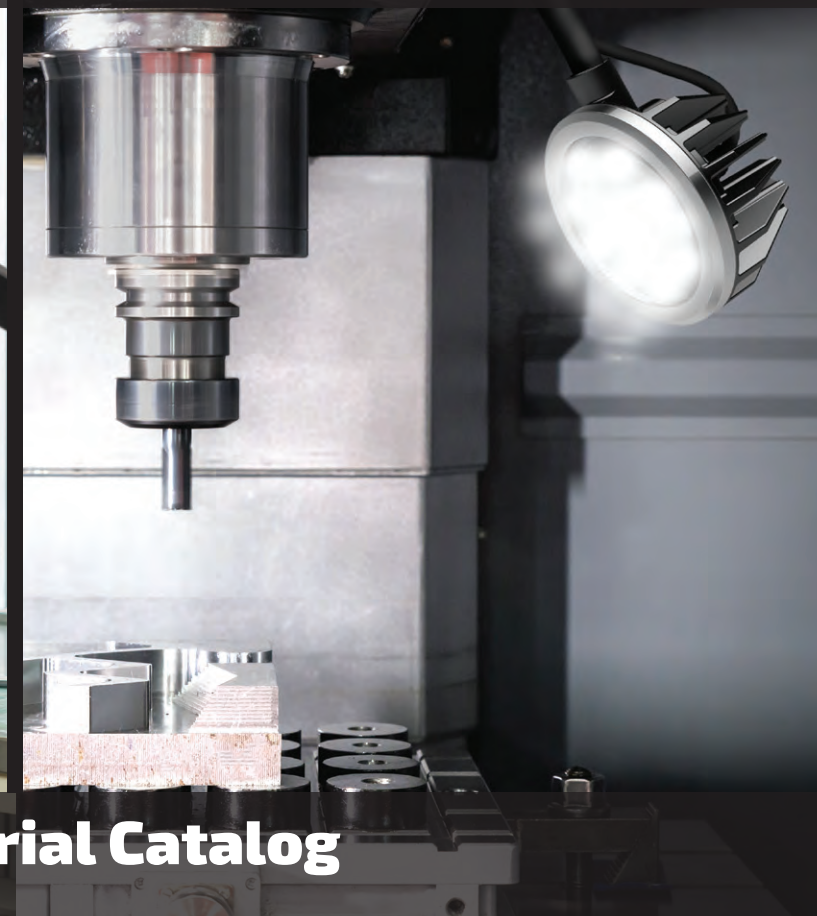

2017 Industrial Catalog

Patent #D723,081 S

## The Industry Standard The Dollars and Sense of Buying Quality

### Best Return On Investment

The Green-Lite® series from O.C. White is the world's most energy efficient, highest output, and longest lasting line of professional inspection magnifiers. Immediate improvements in productivity and quality control inspection equal real bottom line savings.

82400-4-USA

**Optional Add-On Lenses**  
4 Diopter (2x) AO-4D  
& 6 Diopter (2.5x) AO-6D  
with Silicone gasket



### Productivity Improvement

With unmatched standard 4 Diopter (2x) magnification & advanced lighting controls, let us help you catch in-process defects before they reach your customer



### Crown White Glass

Standard in all O.C. White models, this highest resolution glass puts us leaps and bounds ahead of

competition who continue to choose poor quality green tinted glass. If crystal clear resolution and superb color rendition are critical to your inspection, only O.C. White can satisfy.

### Unmatched Efficiency

With efficiency being a paramount concern in today's manufacturing environment, all Green-Lite® models are up to the task. **Our 12 LED models consume only 8w at high**, and our 6 LED models consume a mere 4 watts!

### Intuitive Lighting Controls

Our specialized rugged membrane switch controls all aspects of lighting. Our patented features include **100-5% dimming**, **5 specialized contrast** lit views, integrated shut-off timer for **energy savings**, and light memory... complete control is at your fingertips. This multifunction membrane is also back-lit for increased visibility in darker installations.

#### DIMMABLE: Control Lighting Intensity Smoothly - 5% to 100%



#### CONTRAST: Control Lighting Contrast Quickly - 5 Contrast Views



### Lighting Specifications:

Exceeds all other magnifiers with over **(4X)** the **lumen output** of competition.

- **Reduced glare, heat and energy consumption**
- **Multi-angle LEDs** for shadowless lighting at a full range of focal lengths and heights
- **User controlled LED groups** shine contrasting light exactly where required
- **Auto-Timer shut-off** (user activated)
- **Low 24v design makes this the world's safest**

### Benefits:

- **No Bulbs = \$0 Replacement Cost**
- Ideal color temperature for accurate colors
- Reduction or elimination of eyestrain
- More easily see defects during QA

### Optical Specifications:

Precision ground, crown white optical grade glass provides the highest image resolution with no ghosting or chromatic separation.

- **The largest lenses in the industry.**
- **Four lens sizes to choose from:**
  - 7" x 5.25" Rectangle Lens
  - 7.5" Round Lens
  - 6" Round Lens
  - 5" Round Lens
- **Standard 4 diopter (2x) lens** (an O.C. White exclusive)
  - Optional (2.25X) lens available

### Benefits:

- Best balance of working distance, magnification and field of view
- Most lens size choices in the industry
- Unrivaled lens clarity
- See what you've been missing

Patent #D723,081 S

### The Industry Standard The Dollars and Sense of Buying Quality

#### Best Return On Investment

The Green-Lite® series from O.C. White is the world's most energy efficient, highest output, and longest lasting line of professional inspection magnifiers. Immediate improvements in productivity and quality control inspection equal real bottom line savings.

82400-4-USA

**Optional Add-On Lenses**  
4 Diopter (2x) AO-4D  
& 6 Diopter (2.5x) AO-6D  
with Silicone gasket



#### Productivity Improvement

With unmatched standard 4 Diopter (2x) magnification & advanced lighting controls, let us help you catch in-process defects before they reach your customer

#### Crown White Glass

Standard in all O.C. White models, this highest resolution glass puts us leaps and bounds ahead of

competition who continue to choose poor quality green tinted glass. If crystal clear resolution and superb color rendition are critical to your inspection, only O.C. White can satisfy.

#### Unmatched Efficiency

With efficiency being a paramount concern in today's manufacturing environment, all Green-Lite® models are up to the task. **Our 12 LED models consume only 8w at high**, and our 6 LED models consume a mere 4 watts!

#### Intuitive Lighting Controls

Our specialized rugged membrane switch controls all aspects of lighting. Our patented features include **100-5% dimming**, **5 specialized contrast** lit views, integrated shut-off timer for **energy savings**, and light memory... complete control is at your fingertips. This multifunction membrane is also back-lit for increased visibility in darker installations.

#### DIMMABLE: Control Lighting Intensity Smoothly - 5% to 100%



#### CONTRAST: Control Lighting Contrast Quickly - 5 Contrast Views



#### Lighting Specifications:

Exceeds all other magnifiers with over **(4X)** the **lumen output** of competition.

- **Reduced glare, heat and energy consumption**
- **Multi-angle LEDs** for shadowless lighting at a full range of focal lengths and heights
- **User controlled LED groups** shine contrasting light exactly where required
- **Auto-Timer shut-off** (user activated)
- **Low 24v design makes this the world's safest**

#### Benefits:

- **No Bulbs = \$0 Replacement Cost**
- Ideal color temperature for accurate colors
- Reduction or elimination of eyestrain
- More easily see defects during QA

#### Optical Specifications:

Precision ground, crown white optical grade glass provides the highest image resolution with no ghosting or chromatic separation.

- **The largest lenses in the industry.**
- **Four lens sizes to choose from:**
  - 7" x 5.25" Rectangle Lens
  - 7.5" Round Lens
  - 6" Round Lens
  - 5" Round Lens
- **Standard 4 diopter (2x) lens** (an O.C. White exclusive)
  - Optional (2.25X) lens available

#### Benefits:

- Best balance of working distance, magnification and field of view
- Most lens size choices in the industry
- Unrivaled lens clarity
- See what you've been missing

## Quality Comes Standard!

82400-4-SB

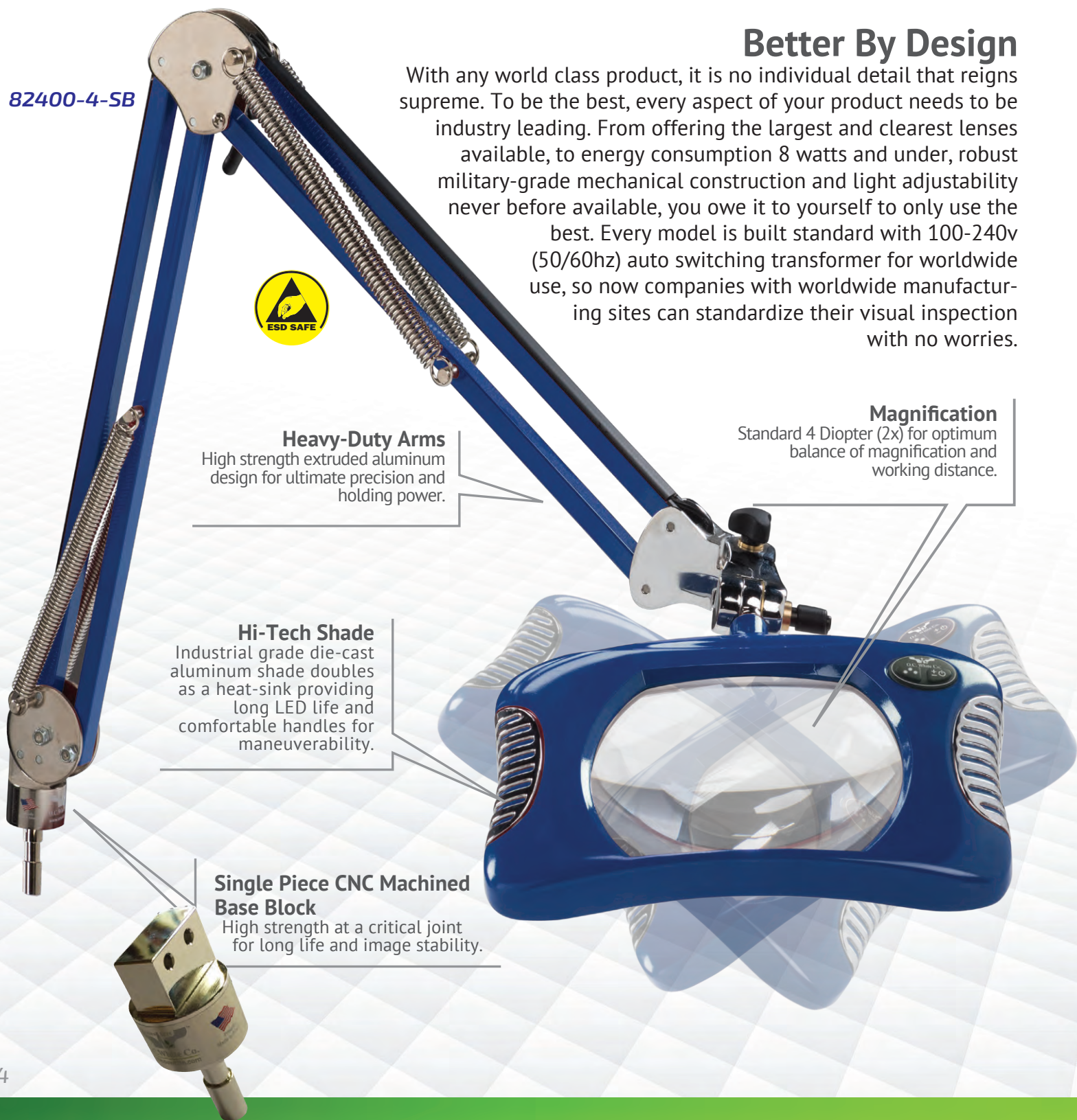

**Heavy-Duty Arms**  
High strength extruded aluminum design for ultimate precision and holding power.

**Hi-Tech Shade**  
Industrial grade die-cast aluminum shade doubles as a heat-sink providing long LED life and comfortable handles for maneuverability.

**Single Piece CNC Machined Base Block**  
High strength at a critical joint for long life and image stability.

### Better By Design

With any world class product, it is no individual detail that reigns supreme. To be the best, every aspect of your product needs to be industry leading. From offering the largest and clearest lenses available, to energy consumption 8 watts and under, robust military-grade mechanical construction and light adjustability never before available, you owe it to yourself to only use the best. Every model is built standard with 100-240v (50/60hz) auto switching transformer for worldwide use, so now companies with worldwide manufacturing sites can standardize their visual inspection with no worries.

**Magnification**  
Standard 4 Diopter (2x) for optimum balance of magnification and working distance.

## Pure Durability Delivers Low Cost of Ownership!



**82400-4-BR / 43" Arm**  
Plenty of reach for the widest range of inspection.



**82400-4-MW**  
shown on optional 11469-MW Base

**No-Tip Rolling Stand**  
Roll your magnifier from task to task with ease. The No-Tip base features 6 large diameter caster wheels and a 35 lb. counter-weight for smooth and safe movement.



**81600-4 / 30" Arm with Weighted Base**  
Built for smaller footprint applications.



**82400-4-UV / Ultraviolet**  
Featuring 8 UV LEDs (395nm) ganged with 4 White LEDs. Easily switch from UV-left, UV-right, White only and UV with White light.



### Choice of 10 Standard Finishes



## Quality Comes Standard!

82400-4-SB

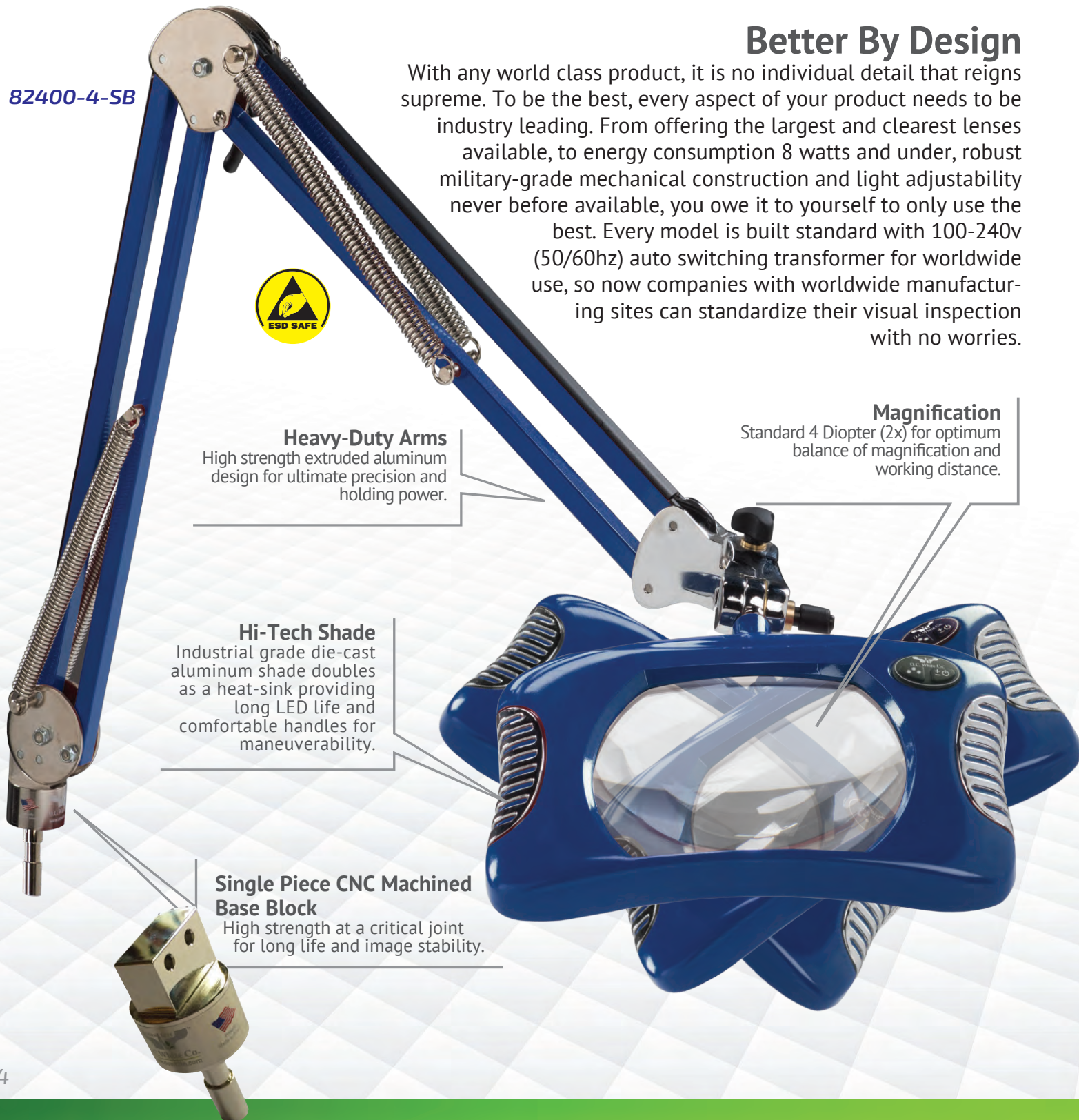

### Better By Design

With any world class product, it is no individual detail that reigns supreme. To be the best, every aspect of your product needs to be industry leading. From offering the largest and clearest lenses available, to energy consumption 8 watts and under, robust military-grade mechanical construction and light adjustability never before available, you owe it to yourself to only use the best. Every model is built standard with 100-240v (50/60hz) auto switching transformer for worldwide use, so now companies with worldwide manufacturing sites can standardize their visual inspection with no worries.



**Heavy-Duty Arms**  
High strength extruded aluminum design for ultimate precision and holding power.

**Magnification**  
Standard 4 Diopter (2x) for optimum balance of magnification and working distance.

**Hi-Tech Shade**  
Industrial grade die-cast aluminum shade doubles as a heat-sink providing long LED life and comfortable handles for maneuverability.

**Single Piece CNC Machined Base Block**  
High strength at a critical joint for long life and image stability.



## Pure Durability Delivers Low Cost of Ownership!



**82400-4-BR / 43" Arm**  
Plenty of reach for the widest range of inspection.



**82400-4-MW**  
shown on optional 11469-MW Base

**No-Tip Rolling Stand**  
Roll your magnifier from task to task with ease. The No-Tip base features 6 large diameter caster wheels and a 35 lb. counter-weight for smooth and safe movement.



**81600-4 / 30" Arm with Weighted Base**  
Built for smaller footprint applications.



**82400-4-UV / Ultraviolet**  
Featuring 8 UV LEDs (395nm) ganged with 4 White LEDs. Easily switch from UV-left, UV-right, White only and UV with White light.



### Choice of 10 Standard Finishes



Patent #D656,527 S

## One BIG Beautiful Magnifier.

### The 7.5" LED Big Eye™ The Biggest in the Industry!



**Heavy-Duty Arms**  
High strength extruded aluminum design for ultimate precision & holding power.

**Hi-Tech Shade**  
Industrial grade die-cast aluminum heat-sink shade provides long LED life and easy handling.



**7.5" ROUND Crown White Glass**  
Huge Optical Quality Lens for the widest working view with the highest visual resolution available anywhere.

**62400-4-B0**  
12 LED



**Lighting Control**  
Specialized membrane switch provides smooth light level control from 100%-5% with special contrast and timer functions built-in.

Equipped with the **largest, highest resolution lens available**, this next generation, surface mount LEDs, is the new standard for illuminated magnifiers. Quickly pays for itself with superior productivity and energy savings. Features the **highest lumen output in a lighted magnifier**, the user controlled LED groups shine desired level of light and illumination contrast exactly how and where you need it.



**42400-4-SB**  
6" Round  
6 LED

**6" Round Magnifier with 6 LEDs**  
6" Round with 12 LEDs also available



**22400-4-BY**  
5" Round  
6 LED

**5" Round Magnifier with 6 LEDs**

## Bigger IS Better!

**Up to 225% LARGER**  
Viewing Area Than Standard 5" Round Magnifiers



## NO COMPARISON: HEAD TO HEAD SHOWDOWN

It doesn't get any clearer than this! Shown below is our best-selling Green-Lite® Rectangle LED magnifier lens, next to a leading competitor's largest rectangle magnifier lens.

**A Full 33% Thicker Glass!**

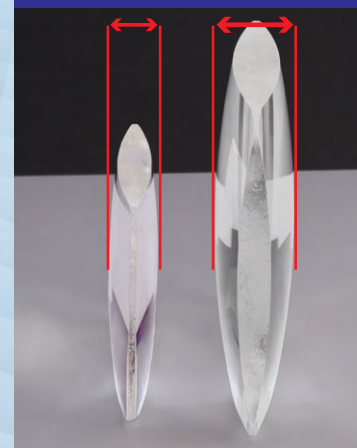

**The Industry's Biggest Glass Comes Standard!**

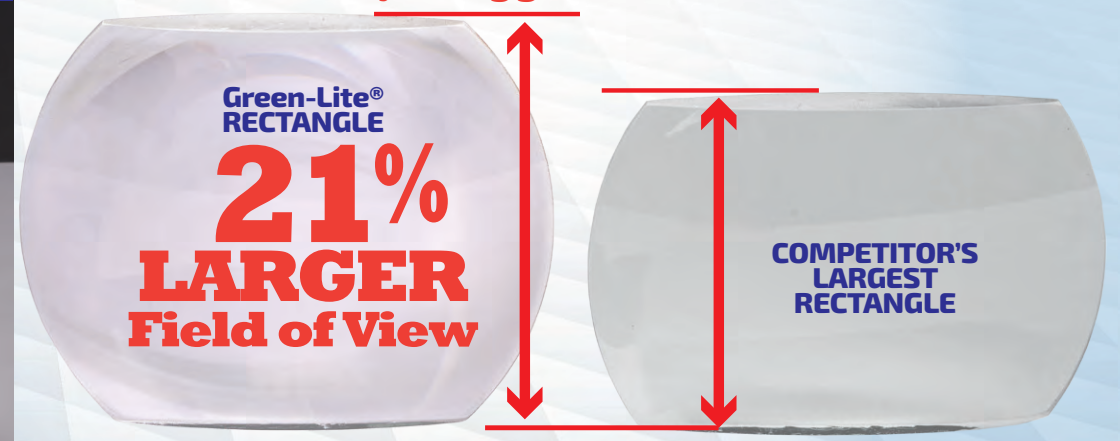

Patent #D656,527 S

## One BIG Beautiful Magnifier.

The 7.5" LED Big Eye™  
The Biggest in the Industry!



**Heavy-Duty Arms**  
High strength extruded aluminum design for ultimate precision & holding power.

**Hi-Tech Shade**  
Industrial grade die-cast aluminum heat-sink shade provides long LED life and easy handling.



**7.5" ROUND Crown White Glass**  
Huge Optical Quality Lens for the widest working view with the highest visual resolution available anywhere.

62400-4-BO  
12 LED

**Lighting Control**  
Specialized membrane switch provides smooth light level control from 100%-5% with special contrast and timer functions built-in.



Equipped with the **largest, highest resolution lens available**, this next generation, surface mount LEDs, is the new standard for illuminated magnifiers. Quickly pays for itself with superior productivity and energy savings. Features the **highest lumen output in a lighted magnifier**, the user controlled LED groups shine desired level of light and illumination contrast exactly how and where you need it.



42400-4-SB  
6" Round  
6 LED

6" Round Magnifier with 6 LEDs  
6" Round with 12 LEDs also available



22400-4-BY  
5" Round  
6 LED

5" Round Magnifier with 6 LEDs

## Bigger IS Better!

Up to **225% LARGER**  
Viewing Area Than Standard 5" Round Magnifiers



## NO COMPARISON: HEAD TO HEAD SHOWDOWN

It doesn't get any clearer than this! Shown below is our best-selling Green-Lite® Rectangle LED magnifier lens, next to a leading competitor's largest rectangle magnifier lens.

A Full 33% Thicker Glass!

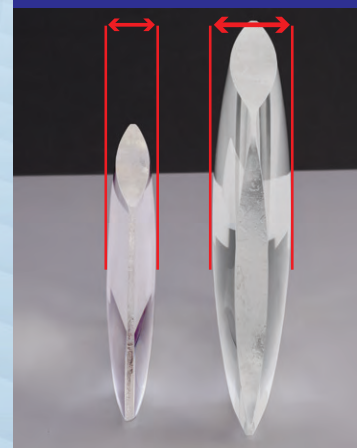

The Industry's Biggest Glass Comes Standard!

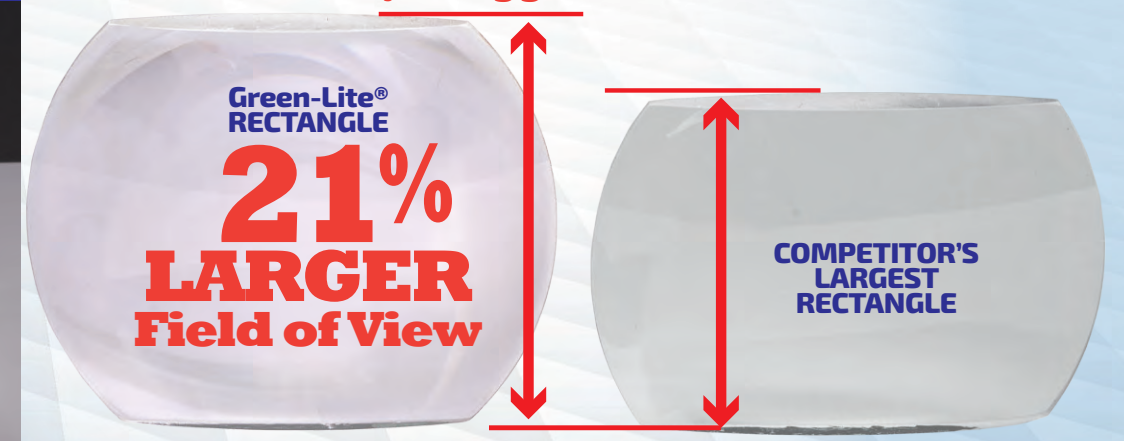

## Machining Perfection

The Perfect Inspection Tool for the Machining Industry

### Heavy-Duty Arms

High strength extruded aluminum design for ultimate precision & holding power. Choice of 30" and 43" reach

### Magnification

Exclusive 3 Diopter (1.75x) TRUE Rectangular lens provides vivid resolution and clarity with zero distortion edge to edge



**7.5 x 6.25" Crown White Glass**  
Excellent optics for excellent inspection.  
**See the Difference for Yourself**

72400-B



*World's Only*  
**TRUE RECTANGULAR**  
MAGNIFIER  
*A DIFFERENCE YOU CAN TRULY SEE!*

## In a World of Copycats and Knockoffs, Vision-Lite® is a Groundbreaker.

This excellent inspection tool is perfect for the machining industry. If you are inspecting polished metal components, exotic materials, or if inspecting surface quality are key to your job, the Vision-Lite® has no equal. The unique 3-sided bulb offers soft, shadowless illumination that will make the smallest details stand out.

One of the key design features is the ONLY TRUE RECTANGULAR LENS. All other manufacturers who advertise 'rectangular' magnifiers are only telling you half the truth. What they are offering is a round lens, with two sides cut flat. You still get edge distortion, and other less desirable optical effects from this. With Vision-Lite® you can get the same level of clarity side to side... we dare you to compare!

**SEEING IS BELIEVING**

**Our Glass is BETTER!**  
*Thicker and More Powerful!*

**39% TALLER VIEWING AREA**

**65% THICKER LENS** Compared to Competitors

**COMPETITOR'S LARGEST RECTANGLE**

## Keeps Getting Better

The Largest Round Lens Fluorescent Magnifier Available for Industry

### Unrivaled Lens Size

Huge 7.5" Round 4 Diopter (2x) crown white glass lens provides the clearest and widest field of view

### Big Eye™ T5 Fluorescent Magnifier

This classic design features an updated slim T5 bulb and high output electronic transformer. Available in standard 4 Diopter (2x) as well as optional 5 Diopter (2.25x) lens. We have also slimmed the overall height of the shade for a sleeker appearance and better functionality. ESD Safe.



52400-4



### Heavy-Duty Arms

High strength extruded aluminum design for ultimate precision & holding power. Choice of 30" and 43" reach arms.



### Standard Magnilite® 5" Round Magnifier

Our original Magnilite®... an industrial standard since the 1960s. This model has also been updated to include heavy duty tri-axis die cast locking swivel and new electronic transformer. Available in standard 3 Diopter (1.75x) as well as 5 Diopter (2.25x). ESD Safe

32400



## Machining Perfection

The Perfect Inspection Tool for the Machining Industry

### Heavy-Duty Arms

High strength extruded aluminum design for ultimate precision & holding power. Choice of 30" and 43" reach

### Magnification

Exclusive 3 Diopter (1.75x) TRUE Rectangular lens provides vivid resolution and clarity with zero distortion edge to edge



*World's Only*  
**TRUE RECTANGULAR**  
MAGNIFIER  
*A DIFFERENCE YOU CAN TRULY SEE!*

**7.5 x 6.25"**  
**Crown White Glass**  
Excellent optics for excellent inspection.  
**See the Difference for Yourself**

72400-B



## In a World of Copycats and Knockoffs, Vision-Lite® is a Groundbreaker.

This excellent inspection tool is perfect for the machining industry. If you are inspecting polished metal components, exotic materials, or if inspecting surface quality are key to your job, the Vision-Lite® has no equal. The unique 3-sided bulb offers soft, shadowless illumination that will make the smallest details stand out.

One of the key design features is the ONLY TRUE RECTANGULAR LENS. All other manufacturers who advertise 'rectangular' magnifiers are only telling you half the truth. What they are offering is a round lens, with two sides cut flat. You still get edge distortion, and other less desirable optical effects from this. With Vision-Lite® you can get the same level of clarity side to side... we dare you to compare!

**SEEING IS BELIEVING**

**Our Glass is BETTER!**  
**Thicker and More Powerful!**

**39% TALLER VIEWING AREA**

**65% THICKER LENS** Compared to Competitors

**COMPETITOR'S LARGEST RECTANGLE**

## Keeps Getting Better

The Largest Round Lens Fluorescent Magnifier Available for Industry

### Unrivaled Lens Size

Huge 7.5" Round 4 Diopter (2x) crown white glass lens provides the clearest and widest field of view

### Big Eye™ T5 Fluorescent Magnifier

This classic design features an updated slim T5 bulb and high output electronic transformer. Available in standard 4 Diopter (2x) as well as optional 5 Diopter (2.25x) lens. We have also slimmed the overall height of the shade for a sleeker appearance and better functionality. ESD Safe.



52400-4



### Heavy-Duty Arms

High strength extruded aluminum design for ultimate precision & holding power. Choice of 30" and 43" reach arms.



### Standard Magnilite® 5" Round Magnifier

Our original Magnilite®... an industrial standard since the 1960s. This model has also been updated to include heavy duty tri-axis die cast locking swivel and new electronic transformer. Available in standard 3 Diopter (1.75x) as well as 5 Diopter (2.25x). ESD Safe

32400



## Making Light Work

### Longline® Draftsman Lamp

While the days of mechanical drafting by pencil and table might be behind us, the need for quality task lighting isn't. It is more critical than ever to have proper light on your work surface. Parts are getting smaller, and real production time costs are increasingly scrutinized.

Standard overhead 4ft. bench lighting simply doesn't provide adequate light at the work surface. Our twin tube, 30 watt Longline® has set the standard for quality, function, and durability. A superior multiform one-piece stamped steel shade offers utmost rigidity and heft in any industrial lighting application. Our die-cast triple axis adjustable swivel assembly ensures that the light will stay where you set it. Ships with (2) 15W HO fluorescent tubes. 120V only



20700



25800

**Heavy Gauge Handspun Shade**  
Rigid 8" spun aluminum shade with vertical heat venting offers high performance with bright white reflective inner liner

**Single Piece CNC Machined Base Block**  
High strength at a critical joint

### Machinists Heavy Duty Task Light

A shop floor staple, our heavy duty machinists task light has been proudly helping machinists and other shop floor production engineers illuminate their work since the 1960s. This industrial quality light has provided unwavering durability and operation in the harshest of environments, at an attractive price.

The light features our handspun 8" rigid aluminum shade with venting and bright white inner liner for light reflectivity. This liner also helps isolate heat from the bulb, so it keeps the shade cool to the touch! Bulb is not included with this light, but it will readily accept most incandescent, compact fluorescent (CFL) and new LED screw in bulbs.

We have also updated this light with new die-cast triple axis adjustable swivel and one-piece CNC machined base pin. See the quality difference for yourself!



## World's Best Bench Fan

### Ultra Exhaust is the Ultimate Bench Exhaust Fan!

For welding or large fume removal jobs, our 550 CFM unit blows it all away. The UL/CSA fan and finger guards provide excellent protection from both operator, and debris. Fan may be adjusted to move air in either direction. Mounted on our 43" long Ultraflex® arms for dependability, strength and easy movement.

This is the most robust, highest quality exhaust fan you can find on the market, bar none.



50010



- ESD Safe
- 10" 550 CFM fan with UL/CSA dual finger guards
- Heavy cast 10" housing for maximum airflow
- 43" Ultraflex® Arm Reach
- New die-cast 3 axis locking swivel for ultimate articulation
- 5 Year Mechanical Warranty
- 120V Only

### Fume Absorber Exhaust Fan with Activated Carbon Filter

Our ESD Safe fume absorber fan features an activated carbon filter, which neutralizes hundreds of noxious fumes that would otherwise cause headaches, nausea and eye irritation. Competitive units are not activated carbon... a major performance difference.

5" 100 CFM fan may be positioned easily from either side to keep your work area fume free and uncluttered. All Metal Construction with ESD Safety. 120V Only.



50020



## Making Light Work

### Longline® Draftsman Lamp

While the days of mechanical drafting by pencil and table might be behind us, the need for quality task lighting isn't. It is more critical than ever to have proper light on your work surface. Parts are getting smaller, and real production time costs are increasingly scrutinized.

Standard overhead 4ft. bench lighting simply doesn't provide adequate light at the work surface. Our twin tube, 30 watt Longline® has set the standard for quality, function, and durability. A superior multiform one-piece stamped steel shade offers utmost rigidity and heft in any industrial lighting application. Our die-cast triple axis adjustable swivel assembly ensures that the light will stay where you set it. Ships with (2) 15W HO fluorescent tubes. 120V only



20700



25800

**Heavy Gauge Handspun Shade**  
Rigid 8" spun aluminum shade with vertical heat venting offers high performance with bright white reflective inner liner

**Single Piece CNC Machined Base Block**  
High strength at a critical joint

### Machinists Heavy Duty Task Light

A shop floor staple, our heavy duty machinists task light has been proudly helping machinists and other shop floor production engineers illuminate their work since the 1960s. This industrial quality light has provided unwavering durability and operation in the harshest of environments, at an attractive price.

The light features our handspun 8" rigid aluminum shade with venting and bright white inner liner for light reflectivity. This liner also helps isolate heat from the bulb, so it keeps the shade cool to the touch! Bulb is not included with this light, but it will readily accept most incandescent, compact fluorescent (CFL) and new LED screw in bulbs.

We have also updated this light with new die-cast triple axis adjustable swivel and one-piece CNC machined base pin. See the quality difference for yourself!



## World's Best Bench Fan

### Ultra Exhaust is the Ultimate Bench Exhaust Fan!

For welding or large fume removal jobs, our 550 CFM unit blows it all away. The UL/CSA fan and finger guards provide excellent protection from both operator, and debris. Fan may be adjusted to move air in either direction. Mounted on our 43" long Ultraflex® arms for dependability, strength and easy movement.

This is the most robust, highest quality exhaust fan you can find on the market, bar none.



50010



- ESD Safe
- 10" 550 CFM fan with UL/CSA dual finger guards
- Heavy cast 10" housing for maximum airflow
- 43" Ultraflex® Arm Reach
- New die-cast 3 axis locking swivel for ultimate articulation
- 5 Year Mechanical Warranty
- 120V Only

### Fume Absorber Exhaust Fan with Activated Carbon Filter

Our ESD Safe fume absorber fan features an activated carbon filter, which neutralizes hundreds of noxious fumes that would otherwise cause headaches, nausea and eye irritation. Competitive units are not activated carbon... a major performance difference.

5" 100 CFM fan may be positioned easily from either side to keep your work area fume free and uncluttered. All Metal Construction with ESD Safety. 120V Only.



50020



## Workplace Ergonomics 101

### Maximize Efficiency and Operator Comfort

A pretty simple concept, but with far reaching implications. Ultima™ EPS marries our award-winning arm technology and world renowned lighting and inspection products together for industry exclusive performance and ultimate ergonomic safety.

### Custom Fit to Each Operator

No two users are alike... let Ultima™ EPS show you that this is no longer an issue. Ultimate adjustability and repositioning allows for users of all heights to quickly and precisely set the inspection tool to their desired location.

### Free Up Work Space

Is your bench STUFFED? Let Ultima™ liberate your work space! Bulky microscope stands, small instrumentation, user input controls... get them all up and out of the way!

#### Keyboard & Mouse Tray



#### Copyholder



Many Additional Accessories!  
Contact Us for More Details



## Professional Grade Scalable Monitor Support for Industry

### “Future-Proof” Scalable Design

Scaleable to meet both today's needs and room for growth tomorrow. Modular function means you're only limited by your imagination.

### Holds Up To (6) 20 lb. Screens At Once!

When we say professional grade, we mean it. Our robust build quality allows for up to 120 lbs. of monitors to be mounted at once.

### Integral Wire Management

Declutter your workspace with our specialized internal wiring channels.



SMS-LD-1



SMS-LD-2



SMS-LD-3



SMS-LD-4



SMS-LD-5



SMS-LD-6

## Workplace Ergonomics 101

### Maximize Efficiency and Operator Comfort

A pretty simple concept, but with far reaching implications. Ultima™ EPS marries our award-winning arm technology and world renowned lighting and inspection products together for industry exclusive performance and ultimate ergonomic safety.

### Custom Fit to Each Operator

No two users are alike... let Ultima™ EPS show you that this is no longer an issue. Ultimate adjustability and repositioning allows for users of all heights to quickly and precisely set the inspection tool to their desired location.

### Free Up Work Space

Is your bench STUFFED? Let Ultima™ liberate your work space! Bulky microscope stands, small instrumentation, user input controls... get them all up and out of the way!

#### Keyboard & Mouse Tray



#### Copyholder



Many Additional Accessories!  
Contact Us for More Details



## Professional Grade Scalable Monitor Support for Industry

### “Future-Proof” Scalable Design

Scalable to meet both today's needs and room for growth tomorrow. Modular function means you're only limited by your imagination.

### Holds Up To (6) 20 lb. Screens At Once!

When we say professional grade, we mean it. Our robust build quality allows for up to 120 lbs. of monitors to be mounted at once.

### Integral Wire Management

Declutter your workspace with our specialized internal wiring channels.



SMS-LD-1



SMS-LD-2



SMS-LD-3

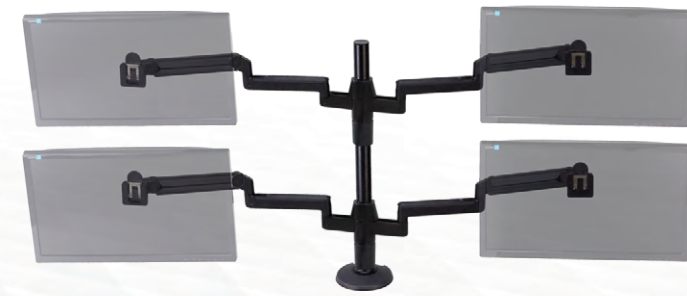

SMS-LD-4



SMS-LD-5



SMS-LD-6

# High Output LED Machine

IP67 RATED LINEAR MACHINE LED LIGHTING

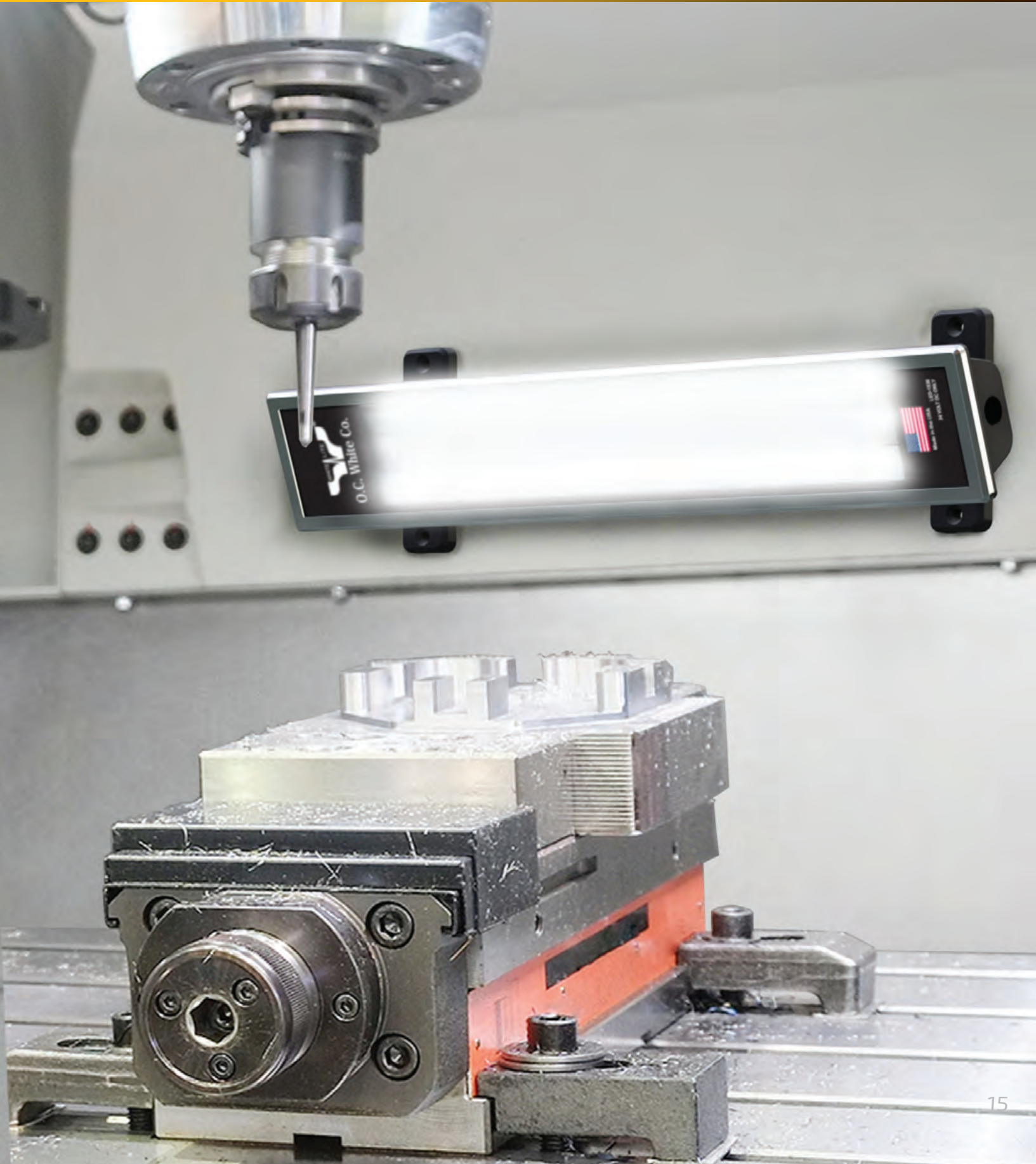
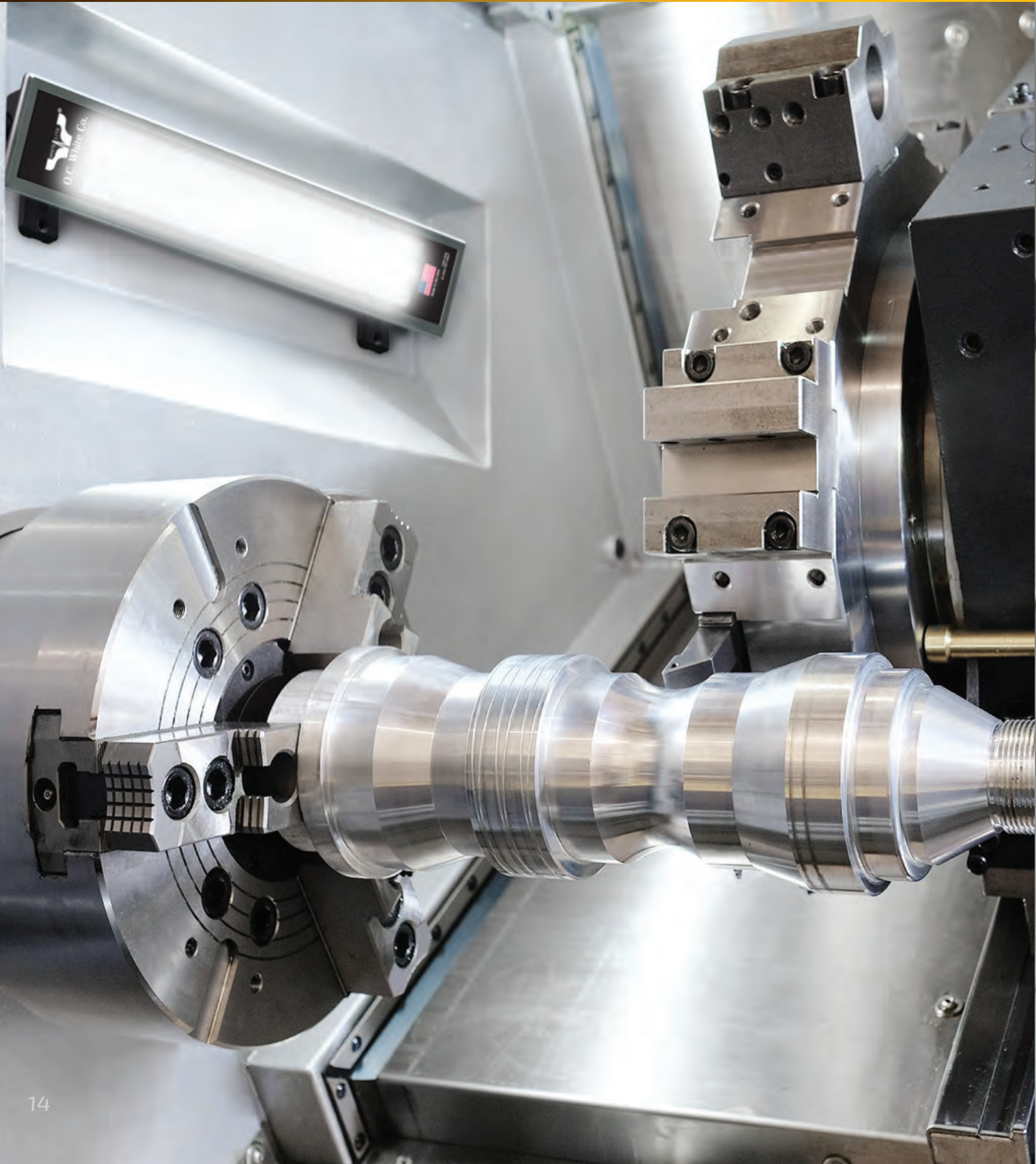

# High Output LED Machine

IP67 RATED LINEAR MACHINE LED LIGHTING

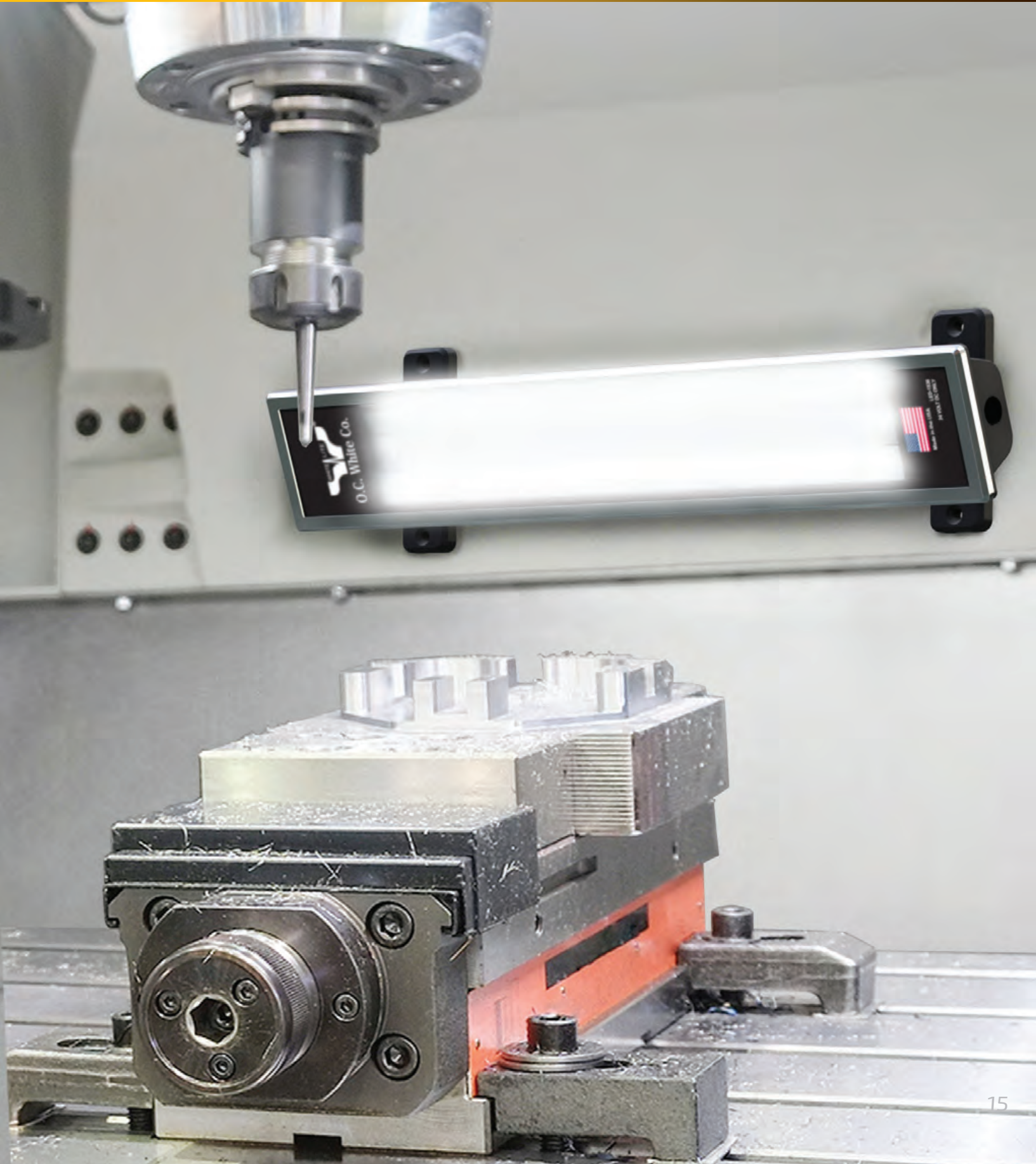
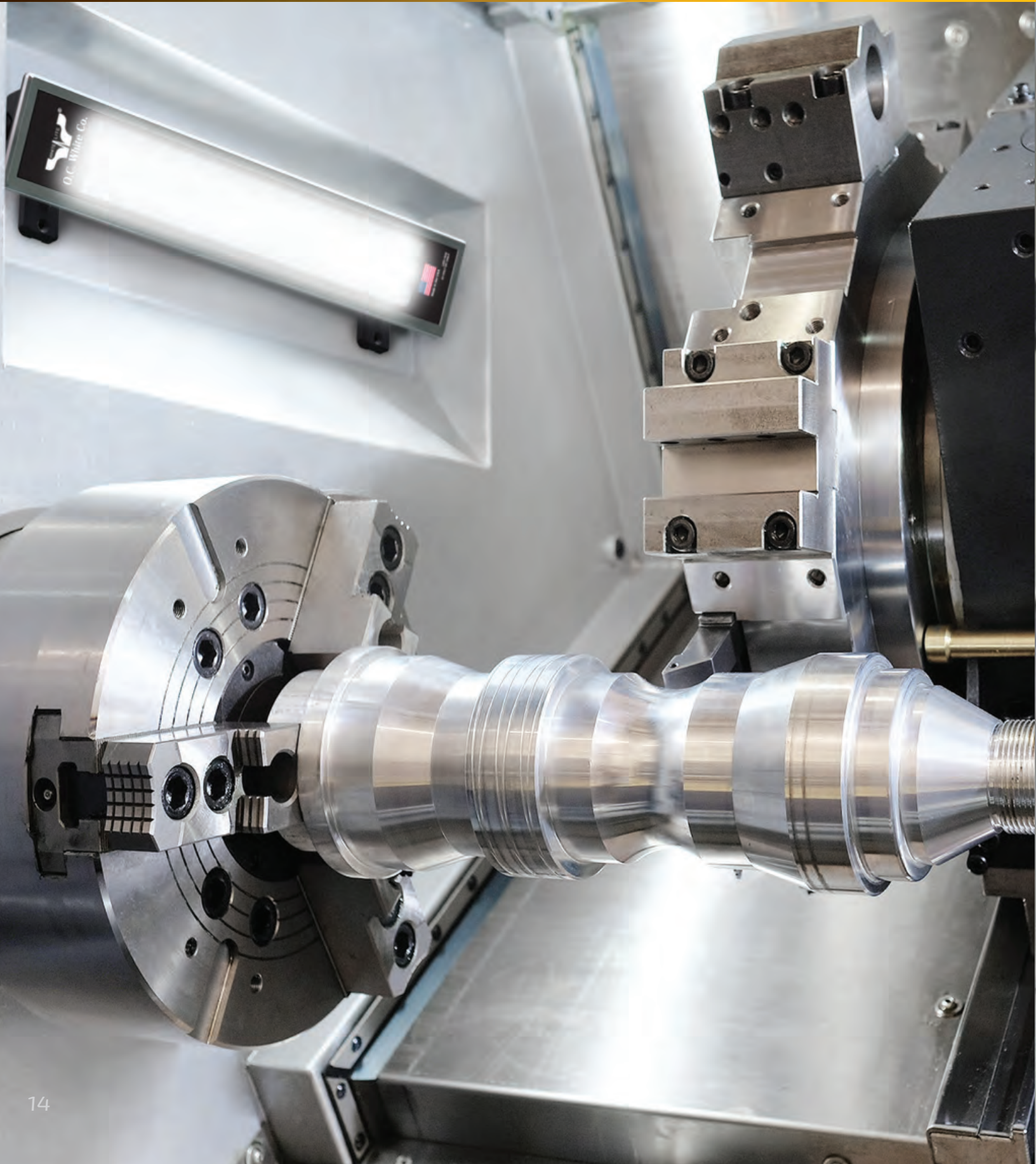

# High Output LED Machine

IP67 RATED LINEAR MACHINE LED LIGHTING

## SERIOUSLY BRIGHT!

### Our Industrial Strength Break-Through

Our Super High Output LED linear machine lighting is the most energy efficient, highest output, and longest lasting machine tool lighting in the world. It will quickly pay for itself through lower operating costs, longer lifespans and improved productivity. Die-cast aluminum body with tempered safety glass ensures reliable performance in the harshest environments.



### Military Grade Construction

The O.C. White High Output LED linear machine light represents the pinnacle of American made quality, sleek design, and outstanding performance. The solid **die-cast aluminum body** construction is for more than just show! It is an integral feature of this light, acting as the heat sink for the LED arrays. This light also features **tempered safety glass** and a slim, nickel plated bezel. It is engineered to withstand even the harshest conditions. Unlike the plastic and thin-walled extrusions our competitors use, this light is made to last a lifetime.



### Low Voltage with Worldwide Appeal

This light can be used on virtually any mill, lathe, grinder, or a variety of other machines in service across the world. Our solid state LED design runs at **24V DC**, which increases operator safety compared to 110/220v lighting! Each light only consumes **38w (1.6A)** also making it one of the most efficient.

### “Green” Long Before It Was Fashionable

This light features exclusive “Patent Pending” thermal dimming controls. If the light gets too hot, it will automatically dim itself to cool down, and greatly extend its service life. Also due to our best-in-class engineering, these fixtures have **TWICE** the light output from the same wattage compared to our competition, and far exceeds the old style fluorescent lights.

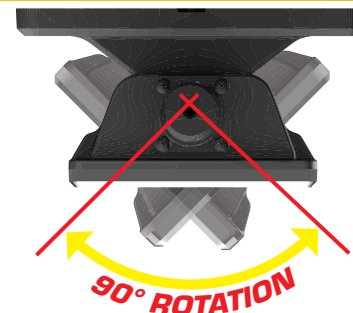
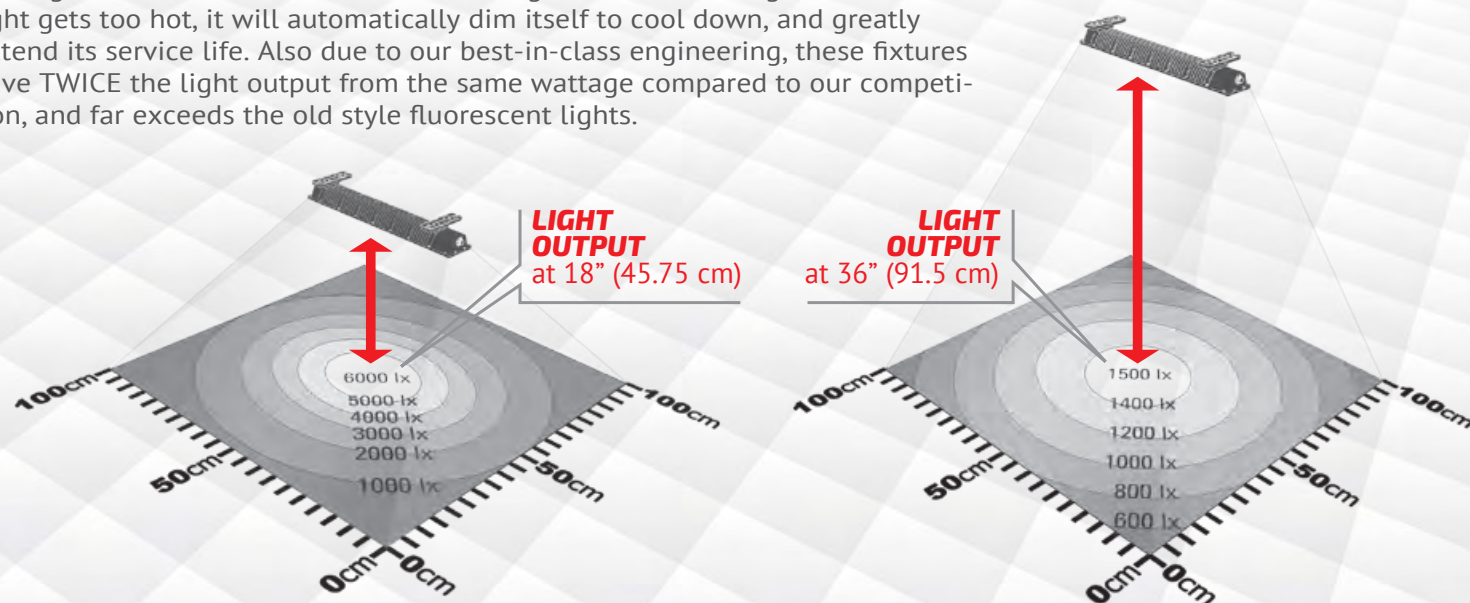

### Adjustable To Any Angle

You can adjust the angle of light 45° in each direction (90° total). This opens up limitless installation possibilities, while still putting the light exactly where you want it.



### Exclusive Quick Magnetic Mount or Permanent Installation

With O.C. White, the choice is yours. Each mounting foot comes complete with a pair of **high strength Neodymium magnets** pre-installed. These allow for a quick magnet mount installation.



Tru Tech Revolution T23X shown with LED-1936 Lighting

### Limitless Installation Possibilities

The specialized design of this light allows for up to (3) fixtures to be run from a single power point. This drastically reduces wire clutter and affords a much faster installation.

#### Standard Configuration

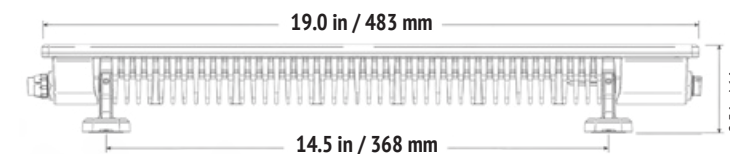
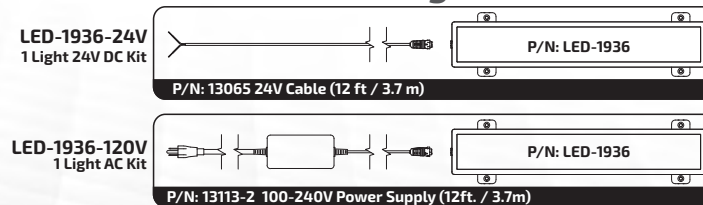

#### Optional Configuration

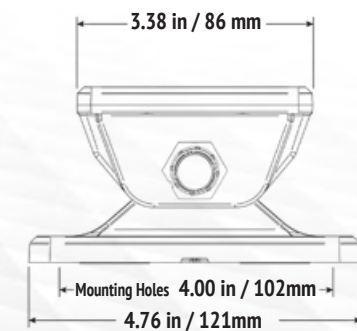
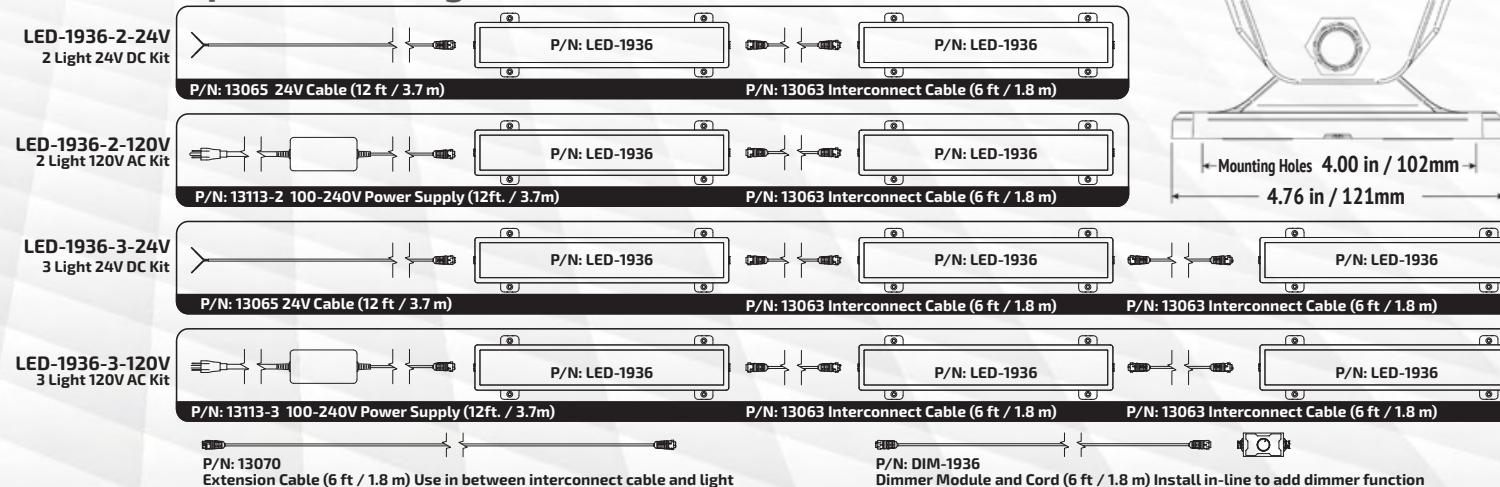

P/N: 13070 Extension Cable (6 ft / 1.8 m) Use in between interconnect cable and light

P/N: DIM-1936 Dimmer Module and Cord (6 ft / 1.8 m) Install in-line to add dimmer function

# High Output LED Machine

IP67 RATED LINEAR MACHINE LED LIGHTING

## SERIOUSLY BRIGHT!

### Our Industrial Strength Break-Through

Our Super High Output LED linear machine lighting is the most energy efficient, highest output, and longest lasting machine tool lighting in the world. It will quickly pay for itself through lower operating costs, longer lifespans and improved productivity. Die-cast aluminum body with tempered safety glass ensures reliable performance in the harshest environments.



### Military Grade Construction

The O.C. White High Output LED linear machine light represents the pinnacle of American made quality, sleek design, and outstanding performance. The solid **die-cast aluminum body** construction is for more than just show! It is an integral feature of this light, acting as the heat sink for the LED arrays. This light also features **tempered safety glass** and a slim, nickel plated bezel. It is engineered to withstand even the harshest conditions. Unlike the plastic and thin-walled extrusions our competitors use, this light is made to last a lifetime.



### Low Voltage with Worldwide Appeal

This light can be used on virtually any mill, lathe, grinder, or a variety of other machines in service across the world. Our solid state LED design runs at **24V DC**, which increases operator safety compared to 110/220v lighting! Each light only consumes **38w (1.6A)** also making it one of the most efficient.

### “Green” Long Before It Was Fashionable

This light features exclusive “Patent Pending” thermal dimming controls. If the light gets too hot, it will automatically dim itself to cool down, and greatly extend its service life. Also due to our best-in-class engineering, these fixtures have **TWICE** the light output from the same wattage compared to our competition, and far exceeds the old style fluorescent lights.

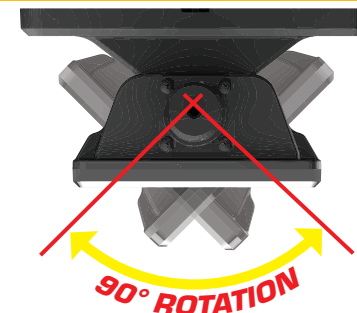
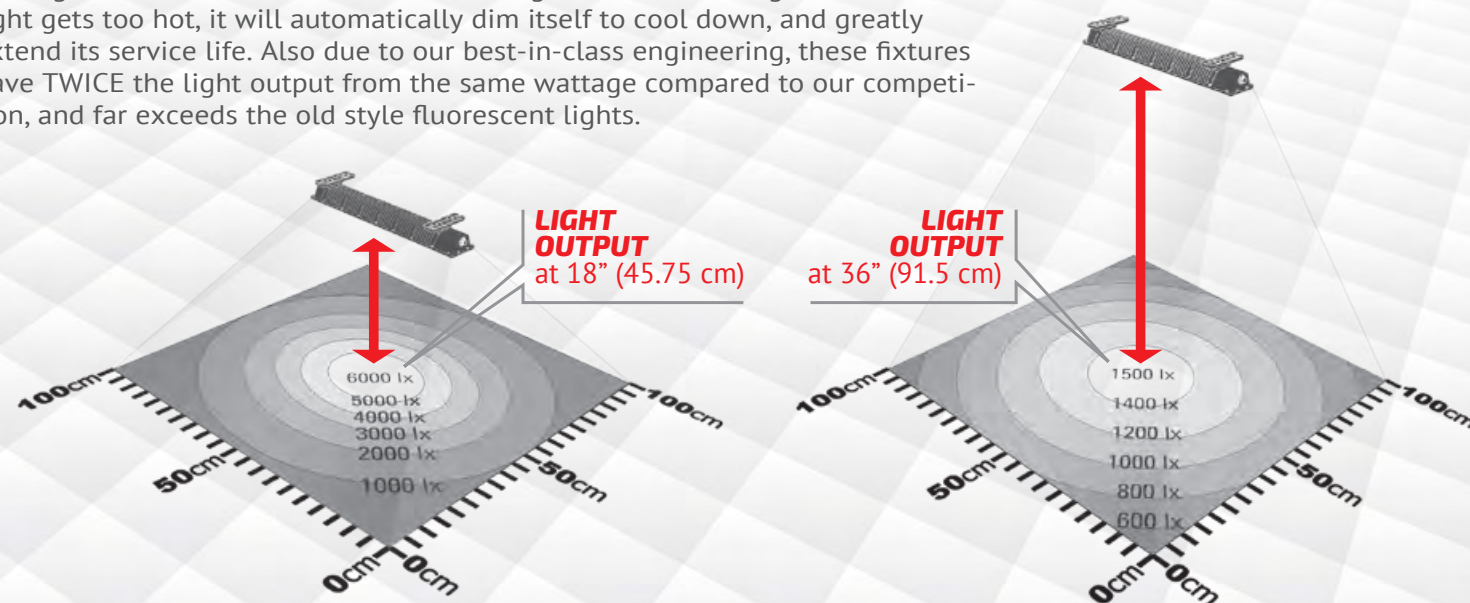

### Adjustable To Any Angle

You can adjust the angle of light 45° in each direction (90° total). This opens up limitless installation possibilities, while still putting the light exactly where you want it.



### Exclusive Quick Magnetic Mount or Permanent Installation

With O.C. White, the choice is yours. Each mounting foot comes complete with a pair of **high strength Neodymium magnets** pre-installed. These allow for a quick magnet mount installation.



Tru Tech Revolution T23X shown with LED-1936 Lighting

### Limitless Installation Possibilities

The specialized design of this light allows for up to (3) fixtures to be run from a single power point. This drastically reduces wire clutter and affords a much faster installation.

#### Standard Configuration

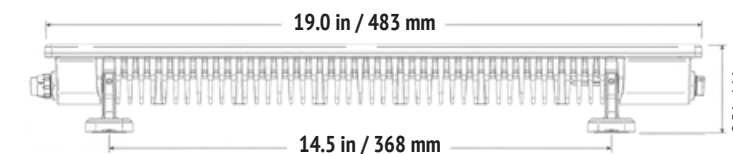
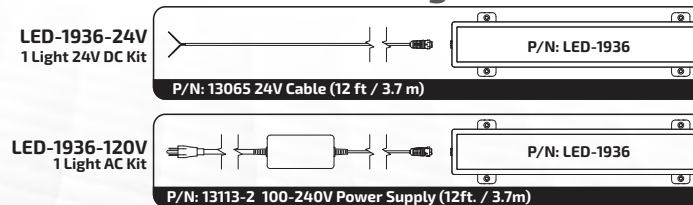

#### Optional Configuration

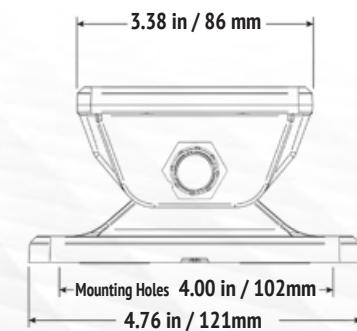
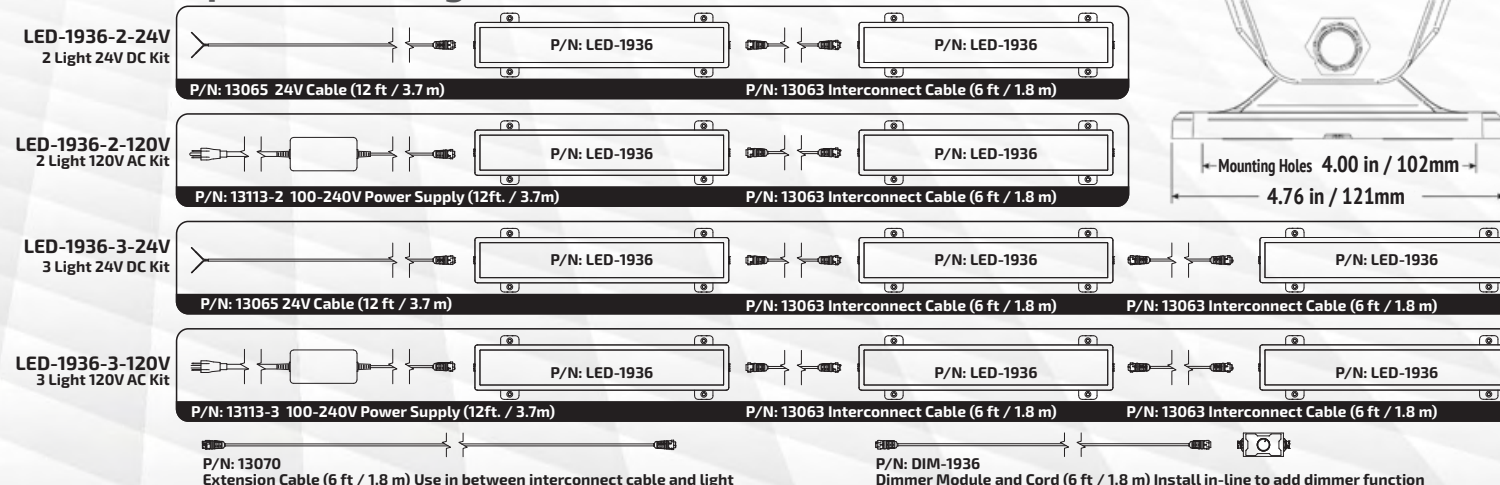

P/N: 13070 Extension Cable (6 ft / 1.8 m) Use in between interconnect cable and light

P/N: DIM-1936 Dimmer Module and Cord (6 ft / 1.8 m) Install in-line to add dimmer function

# High Output LED Machine

IP67 RATED SPOT-LITE MACHINE LED LIGHTING

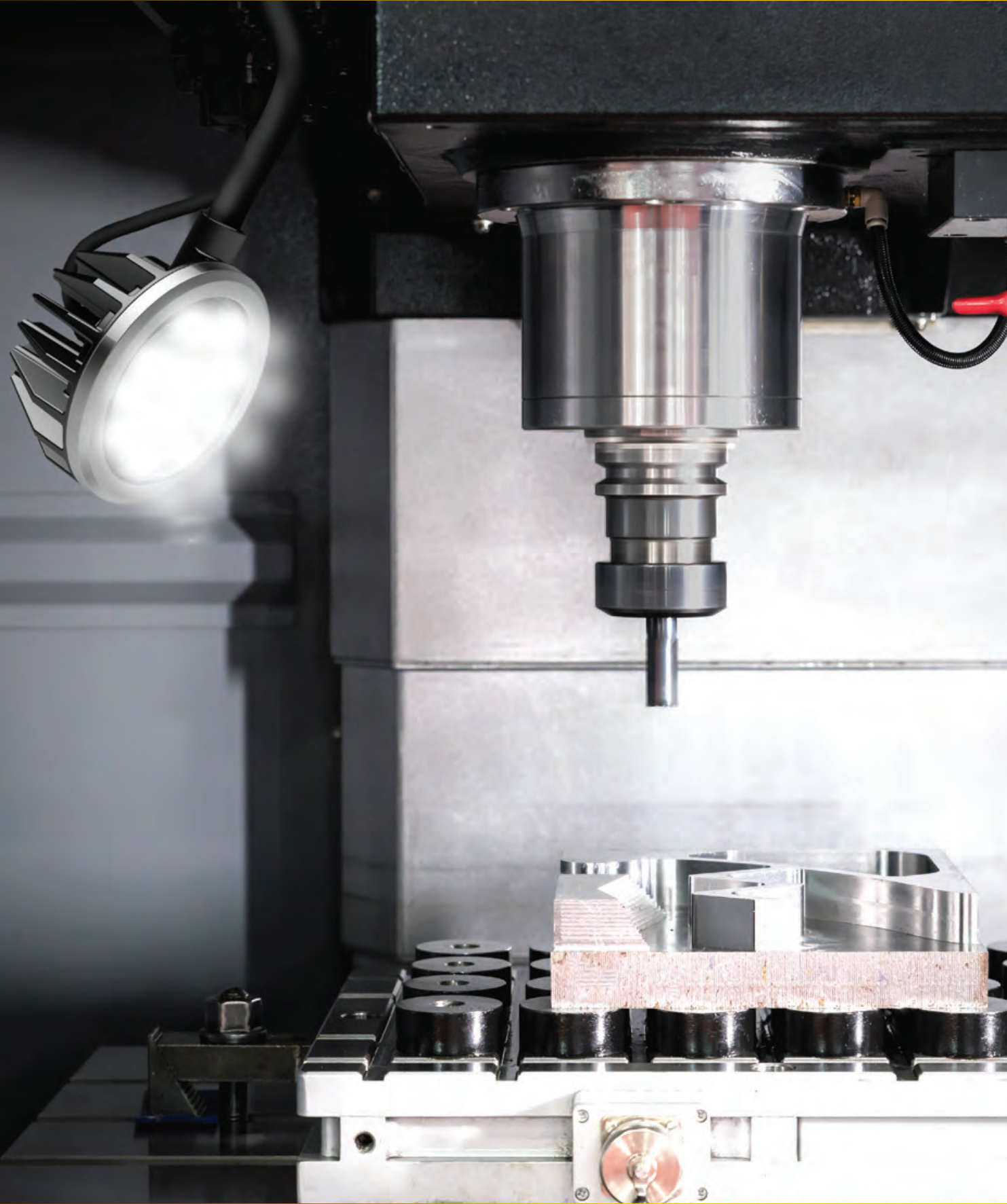

# High Output LED Machine

IP67 RATED SPOT-LITE MACHINE LED LIGHTING

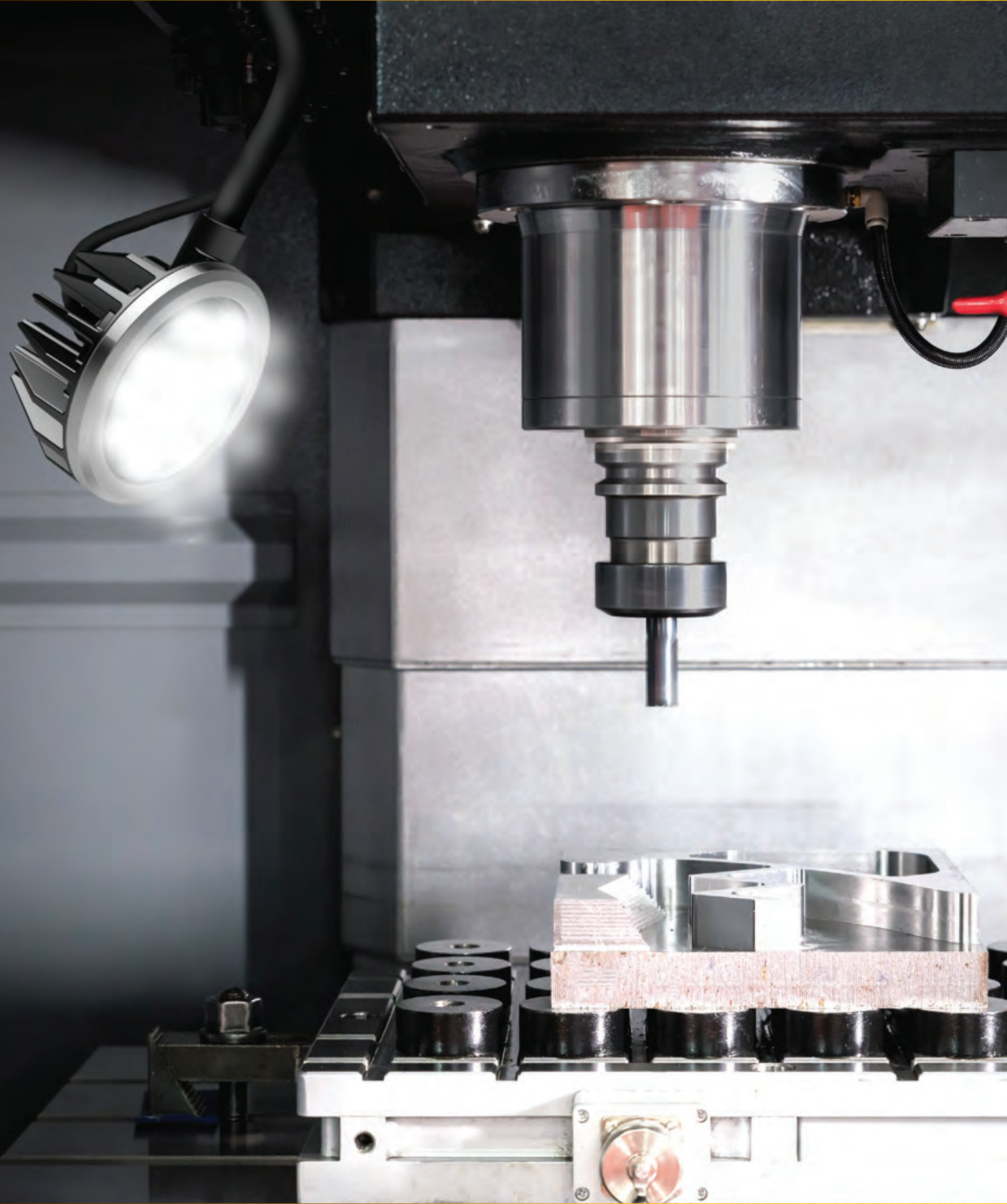

# High Output LED Machine

IP67 RATED SPOT-LITE MACHINE LED LIGHTING

## Compact & Powerful LED Lighting for Swiss-style Machining

### Next Generation LED Spot Lighting

The new Spot-Lite is the perfect addition to any CNC machine - enclosed or not! Our LED Spot-Lite builds on our sophisticated LED technology to provide users with unrivaled lighting.

### Say Goodbye to Your Old Halogen!

Hot and dangerous bulbs are a thing of the past! Upgrade your machine to cool LED lighting - you'll see immediate improvements in set-up times and no loss of production time replacing bulbs!



**Locking Die-cast Swivel Base**  
Locks up solid at any angle 180° Adjustment Range

LED-WSL-SS  
-10-24v



**IP67 Gasketing**  
Specialized design ensures leak-proof performance over the entire life of the light.

**Tempered Safety Glass**  
Anything can happen in a CNC enclosure - you'll appreciate this added safety and piece of mind.

**10° Precision Focused LEDs**  
Great care and thought went into designing this spotlight. Maximum light with even spread ensures ideal lighting for any machine.



### THERE'S MORE ONLINE!

For complete specifications on all OC White machine lighting - including accessories, please visit:

[www.ocwhite.com](http://www.ocwhite.com)



**3" Neodymium Magnet**  
Your choice between permanent screw mount or magnet. Competitive units can't match the holding power.

### Minimal Maintenance

It is up to the operator to regularly clean rear heat fins to ensure long service life. Cool LEDs are happy LEDs.

### Compatible with LED-1936 Linear

The light can be daisy-chained into series with our high output linear LED (end position). This allows you to light the largest cabinets, but also provide spot light exactly where required.



LED-WSL-MG18-10-24v

### Mounting Choices

- "Head Only" Magnet & Swivel
- 12 or 18" Gooseneck
- 30 or 43" Spring Arm

**Integrated Dimming**  
Each IP67 light features a built-in dimming switch with a 100-5% dimming range.



# High Output LED Machine

IP67 RATED SPOT-LITE MACHINE LED LIGHTING

## Compact & Powerful LED Lighting for Swiss-style Machining

### Next Generation LED Spot Lighting.

The new Spot-Lite is the perfect addition to any CNC machine - enclosed or not! Our LED Spot-Lite builds on our sophisticated LED technology to provide users with unrivaled lighting.

### Say Goodbye to Your Old Halogen!

Hot and dangerous bulbs are a thing of the past! Upgrade your machine to cool LED lighting - you'll see immediate improvements in set-up times and no loss of production time replacing bulbs!

**Locking Die-cast Swivel Base**  
Locks up solid at any angle 180° Adjustment Range



**IP67 Gasketing**  
Specialized design ensures leak-proof performance over the entire life of the light.

**Tempered Safety Glass**  
Anything can happen in a CNC enclosure - you'll appreciate this added safety and piece of mind.

**10° Precision Focused LEDs**  
Great care and thought went into designing this spotlight. Maximum light with even spread ensures ideal lighting for any machine.



LED-WSL-SS  
-10-24v

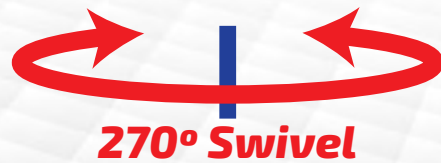

### THERE'S MORE ONLINE!

For complete specifications on all OC White machine lighting - including accessories, please visit:

[www.ocwhite.com](http://www.ocwhite.com)



**3" Neodymium Magnet**  
Your choice between permanent screw mount or magnet. Competitive units can't match the holding power.

### Minimal Maintenance

It is up to the operator to regularly clean rear heat fins to ensure long service life. Cool LEDs are happy LEDs.

### Compatible with LED-1936 Linear

The light can be daisy-chained into series with our high output linear LED (end position). This allows you to light the largest cabinets, but also provide spot light exactly where required.

### Mounting Choices

- "Head Only" Magnet & Swivel
- 12 or 18" Gooseneck
- 30 or 43" Spring Arm

**Integrated Dimming**  
Each IP67 light features a built-in dimming switch with a 100-5% dimming range.



LED-WSL-MG18-10-24v



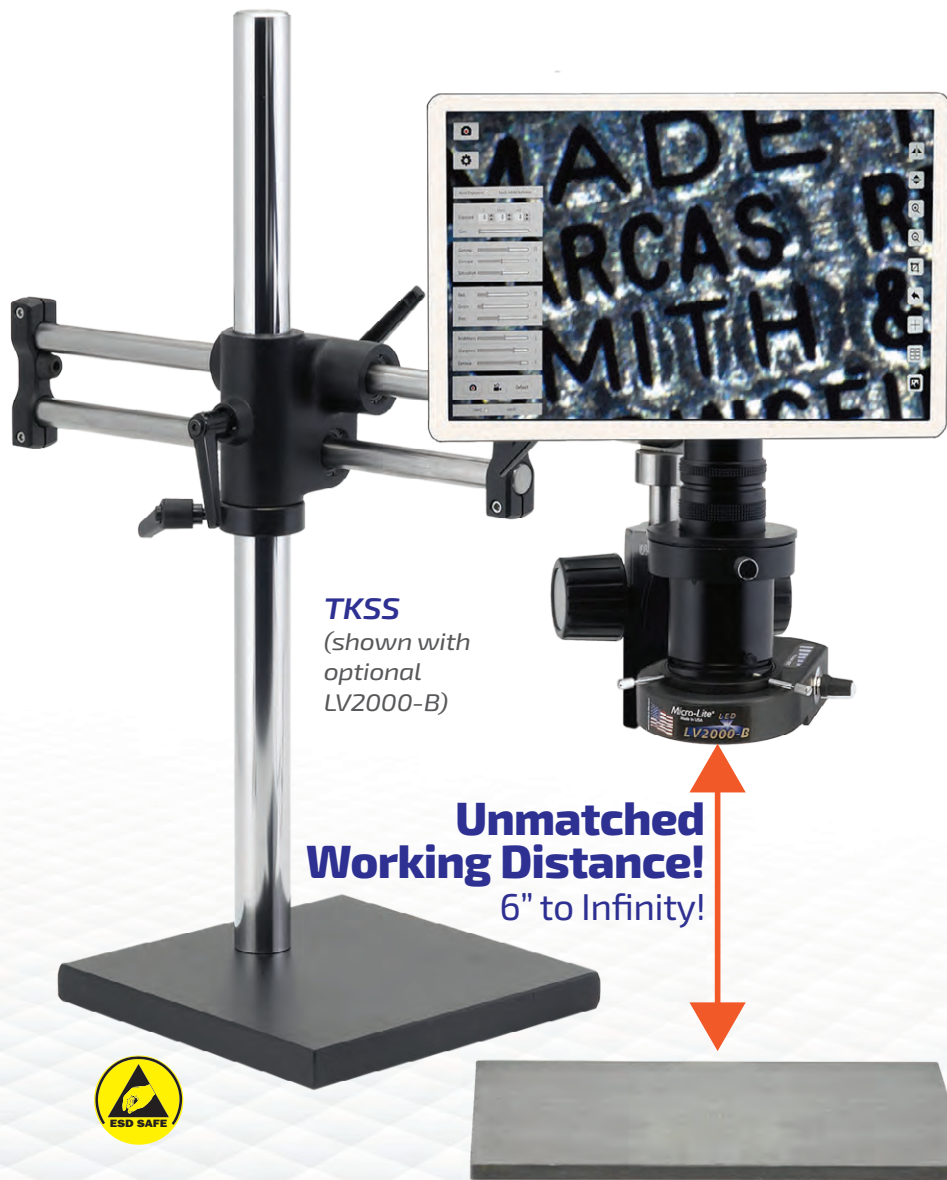

**TKSS**  
(shown with optional LV2000-B)

**Unmatched Working Distance!**  
6" to Infinity!



## Ultimate Ergonomics

Ergonomic design and operator comfort go hand in hand. Unlike microscopes with restrictive eyepieces, **Super-Scope®** features 'heads up' viewing for greatly reduced eyestrain, neck fatigue, and improved posture.

The **large working distance** range means that any height operator can readjust to fit them easily. EH&S personnel can see immediate benefit.

## Need Up to 400X Magnification?

CONTACT US FOR DETAILS ON THE NEW **SUPER-SCOPE® MICRO ZOOM INSPECTION SYSTEM!**

# Simply Better.

## Competes with Inspection Stations over \$10k... at a Fraction of the Price!

**Super-Scope®** stands heads and shoulders above its competition. This unique inspection system boasts features found on much more expensive equipment. Its freestanding design allows for use anywhere on the manufacturing floor... no need for a PC!

The heart of the **Super-Scope®** is our **5MP Hybrid HDMI/USB camera with 12" Integrated LED screen**. Featuring full 1080 resolution (300dpi) for super detailed 'heads up' viewing, this camera features onboard tools including Image & Video capture, calibrated measurement, split screen live view, and more! An 8GB SD Card is included standard for easy transfer.

This system features our **exclusive varifocal lens technology**, which allows for up to 80x magnification and working distances that can be measured in FEET not inches! Each system ships standard with our 24" tall double ball bearing base (other mounting styles available).

- **Infinite Focal Length** Inspect from 6" Working Distance to Infinity
- **5MP Hybrid HDMI/USB Camera** Exclusive Design Works without a PC
- **1-40x Standard Magnification** Up to 80x with Options
- **Built-in Software** No PC Needed! See full features list on the following pages
- **No Light Needed** Industry-Leading Low Light Sensitivity
- **Split Screen Display** Captured vs. Live Image Comparison Tool
- **Built with ESD Safety Construction and Materials**

## Unlimited Inspection Applications

Our **MacroZoom** series is a specialized ergonomic inspection system that pairs a large magnification range (**up to 80x**), with unheard of working distance, depth of field (area vertically in focus) and user control.

These systems fill the need for large field of view inspection, high magnification, and almost **unlimited working distance**. Unlike a microscope, which limits you to strict working distances, **MacroZoom's** one-touch variable focal optical design allows for refocusing in a flash, at any working height! Built with ESD Safety Construction and Materials.

### STANDARD FEATURES

- **5MP Hybrid HDMI/USB Camera** with Advanced Onboard Imaging Controls
- **Extended Height 24" Ball Bearing Base** for Increased Adjustability
- **Unlimited Working Distance** 6" to ∞
- **Range up to 120x** with options

### ONBOARD SOFTWARE FEATURES

- Image & Video Capture
- Browse Saved Images
- Split-Screen Compare
- Calibrated Measurement
- Digital Zoom with H/V Image Invert
- Region of Interest Cropping
- Crosshair Overlay
- Calibration Bar
- Data Export to Excel or TXT File
- And More!

### EXCLUSIVE FEATURES INCLUDED WITH OUR HD2 ADVANCED IMAGING & MEASUREMENT PC SUITE:

- Extended Depth of Focus Stacking
- Advanced Fluorescence Imaging Controls (HDR)
- Image Stitching Combines Multiple Images for Super-Large Field of View
- Multiple Advanced Measurement Tools with Micron-Level Accuracy (down to 10nm)
- Region of Interest Cropping
- Crosshair Overlay
- Calibration Bar
- Data Export to Excel or TXT File
- Learn More About It on the Following Pages!



**TKMACZ**  
with 22" LED Monitor  
(shown with optional LV2000-B)

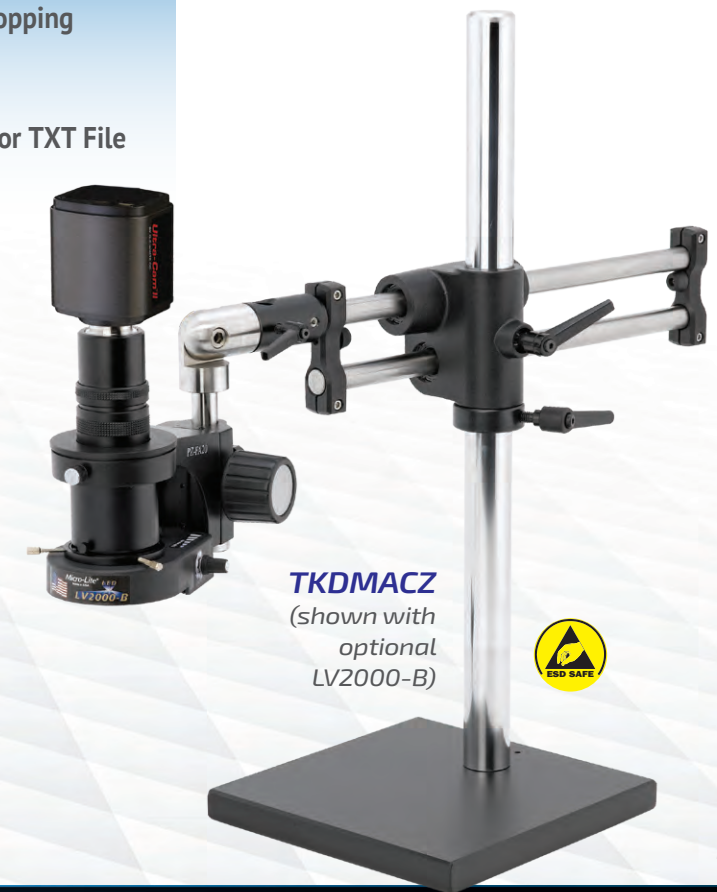

**TKDMACZ**  
(shown with optional LV2000-B)



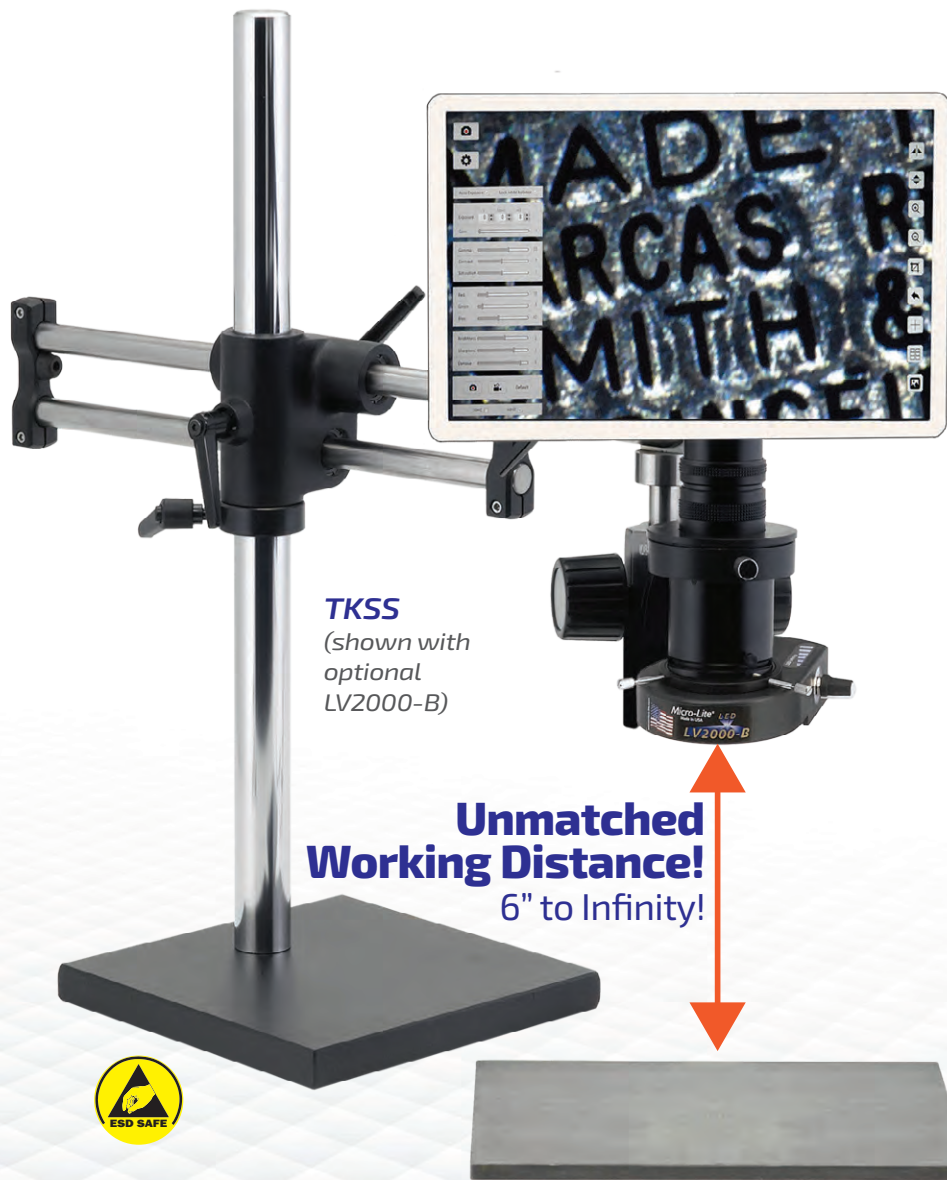

**TKSS**  
(shown with optional LV2000-B)

**Unmatched Working Distance!**  
6" to Infinity!



## Ultimate Ergonomics

Ergonomic design and operator comfort go hand in hand. Unlike microscopes with restrictive eyepieces, **Super-Scope®** features 'heads up' viewing for greatly reduced eyestrain, neck fatigue, and improved posture.

The **large working distance** range means that any height operator can readjust to fit them easily. EH&S personnel can see immediate benefit.

## Need Up to 400X Magnification?

CONTACT US FOR DETAILS ON THE NEW **SUPER-SCOPE® MICRO ZOOM INSPECTION SYSTEM!**

# Simply Better.

## Competes with Inspection Stations over \$10k... at a Fraction of the Price!

**Super-Scope®** stands heads and shoulders above its competition. This unique inspection system boasts features found on much more expensive equipment. Its freestanding design allows for use anywhere on the manufacturing floor... no need for a PC!

The heart of the **Super-Scope®** is our **5MP Hybrid HDMI/USB camera with 12" Integrated LED screen**. Featuring full 1080 resolution (300dpi) for super detailed 'heads up' viewing, this camera features onboard tools including Image & Video capture, calibrated measurement, split screen live view, and more! An 8GB SD Card is included standard for easy transfer.

This system features our **exclusive varifocal lens technology**, which allows for up to 80x magnification and working distances that can be measured in FEET not inches! Each system ships standard with our 24" tall double ball bearing base (other mounting styles available).

- **Infinite Focal Length** Inspect from 6" Working Distance to Infinity
- **5MP Hybrid HDMI/USB Camera** Exclusive Design Works without a PC
- **1-40x Standard Magnification** Up to 80x with Options
- **Built-in Software** No PC Needed! See full features list on the following pages
- **No Light Needed** Industry-Leading Low Light Sensitivity
- **Split Screen Display** Captured vs. Live Image Comparison Tool
- **Built with ESD Safety Construction and Materials**

## Unlimited Inspection Applications

Our **MacroZoom** series is a specialized ergonomic inspection system that pairs a large magnification range (**up to 80x**), with unheard of working distance, depth of field (area vertically in focus) and user control.

These systems fill the need for large field of view inspection, high magnification, and almost **unlimited working distance**. Unlike a microscope, which limits you to strict working distances, **MacroZoom's** one-touch variable focal optical design allows for refocusing in a flash, at any working height! Built with ESD Safety Construction and Materials.

### STANDARD FEATURES

- **5MP Hybrid HDMI/USB Camera** with Advanced Onboard Imaging Controls
- **Extended Height 24" Ball Bearing Base** for Increased Adjustability
- **Unlimited Working Distance** 6" to ∞
- **Range up to 120x** with options

### ONBOARD SOFTWARE FEATURES

- Image & Video Capture
- Browse Saved Images
- Split-Screen Compare
- Calibrated Measurement
- Digital Zoom with H/V Image Invert
- Region of Interest Cropping
- Crosshair Overlay
- Calibration Bar
- Data Export to Excel or TXT File
- And More!

### EXCLUSIVE FEATURES INCLUDED WITH OUR HD2 ADVANCED IMAGING & MEASUREMENT PC SUITE:

- Extended Depth of Focus Stacking
- Advanced Fluorescence Imaging Controls (HDR)
- Image Stitching Combines Multiple Images for Super-Large Field of View
- Multiple Advanced Measurement Tools with Micron-Level Accuracy (down to 10nm)
- Region of Interest Cropping
- Crosshair Overlay
- Calibration Bar
- Data Export to Excel or TXT File
- Learn More About It on the Following Pages!



**TKMACZ**  
with 22" LED Monitor  
(shown with optional LV2000-B)

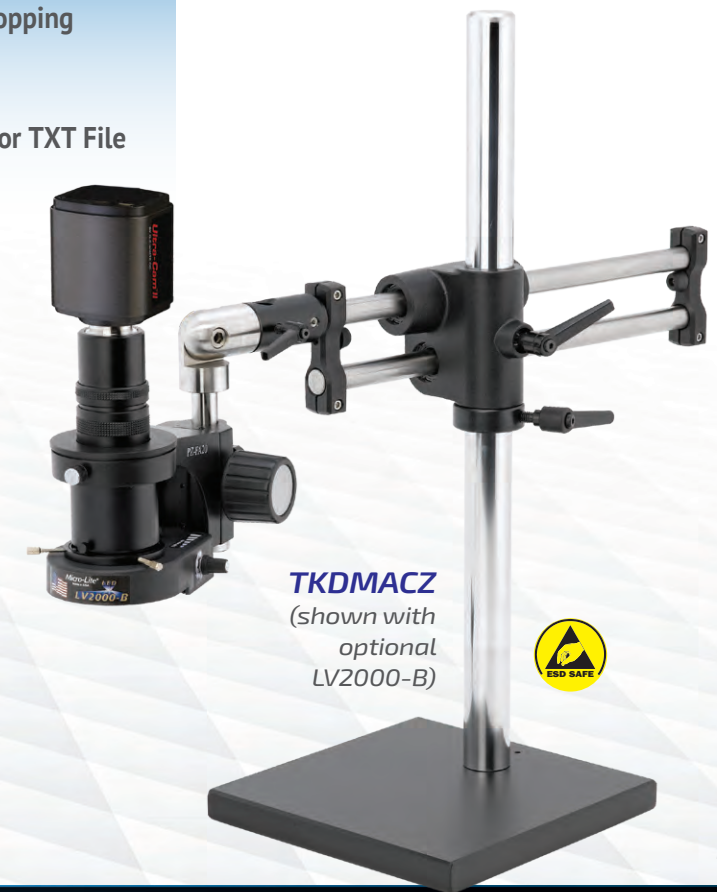

**TKDMACZ**  
(shown with optional LV2000-B)



## Full Functionality Without Using a PC!

The Built-In **Advanced Imaging & Measurement Suite** Comes Out of the Box Ready for Bench Production.



### Browse Captured Images

Quickly scan through previously saved image and video captures. This full field archive allows for quick image pull-up and the ability to sort and delete images no longer needed.

An **8GB SD card** is included with every system to transfer images and videos from system to remote PC for archiving, emailing, etc.



### Compare While Working

Upper Right-hand window features the **live video feed**, while all previously captured images are tiled around it.

This feature allows for real-time searching of previously captured good (or bad) examples for instant comparison.

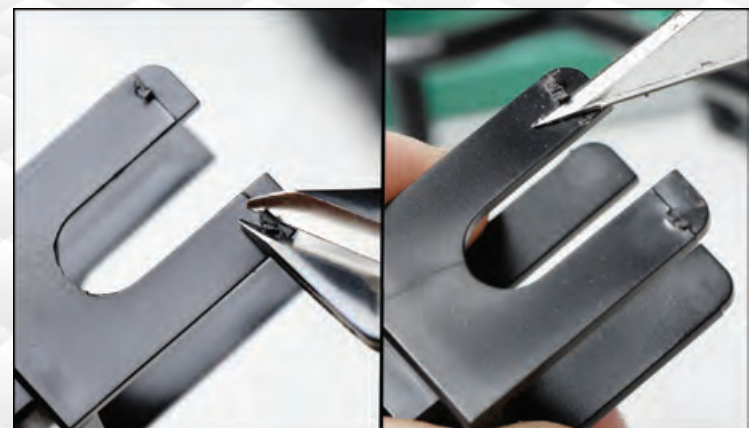

### Split Screen Viewing

Excellent training tool! Pull up a previously saved capture (left pane) and compare with live image on the right! This interactive screen is excellent for showcasing pass/fail to multiple people at once.

Ever have to train a group of new employees all at once? It has never been easier for all employees to see the same details, at the same time.

## Calibrated Onboard Measurement Couldn't Be Easier!

An Entire Array of Measurement Tools for High Precision, Repeatable Measurements. All Without Using a PC!

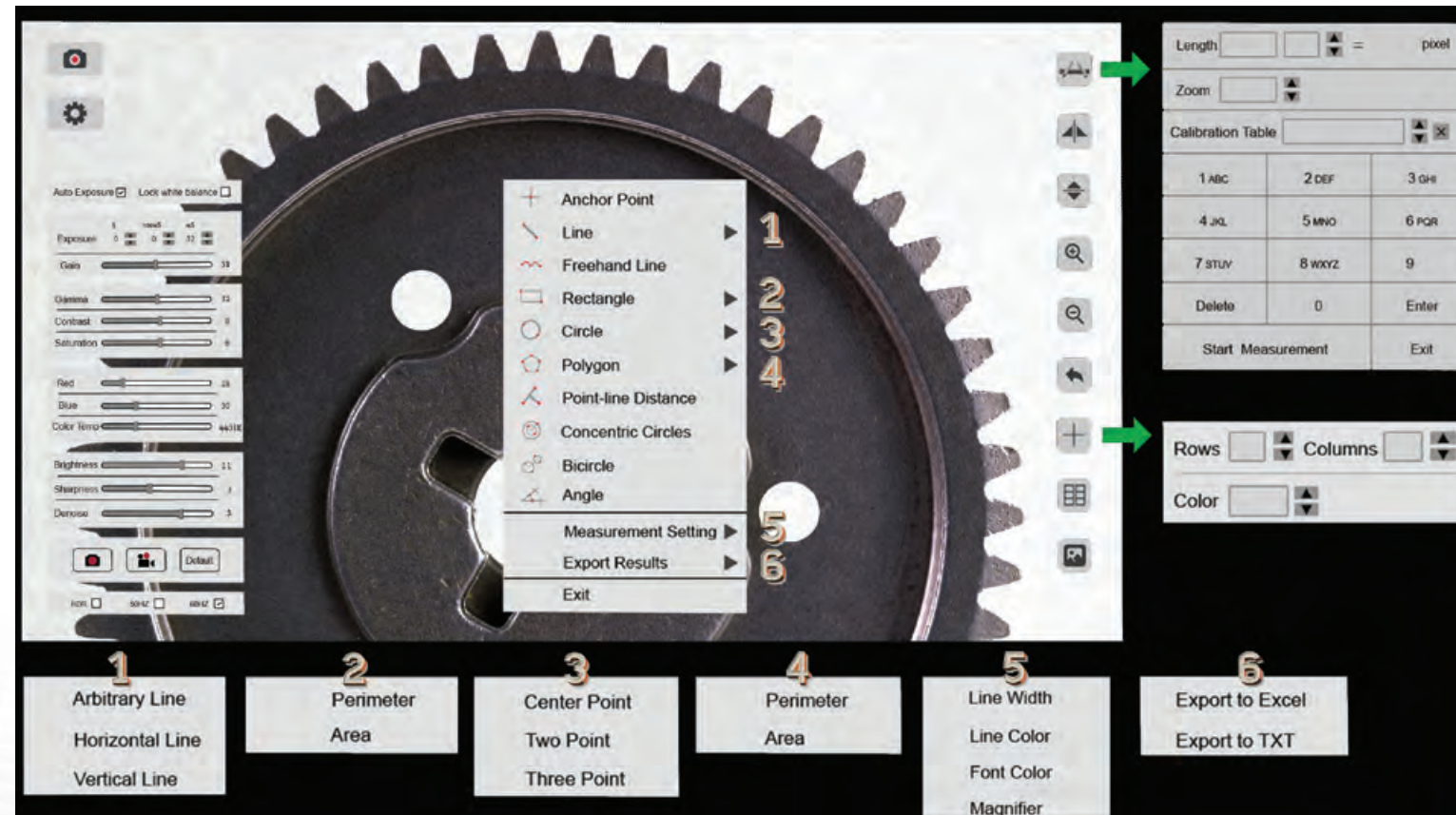

### Exclusive Features Found Only in Advanced Imaging & Measurement PC Suite



#### Extended Depth of Focus

This specialized tool allows for 'stacking' of multiple image captures taken at various focal lengths, into a single super clear image.

This tool is excellent for showcasing **super high clarity images** of tall items that are outside of the capabilities of optical clarity alone. No longer must you settle with images that are good enough... make them great!



#### Image Stitching

Inspecting something that is just too big to view all at once? This handy feature allows you to capture multiple images of the part, then 'stitch' them together digitally to **create a single extra-large image**. This technology is now available to you, with all of the quality you expect from O.C. White.

## Full Functionality Without Using a PC!

The Built-In **Advanced Imaging & Measurement Suite** Comes Out of the Box Ready for Bench Production.



### Browse Captured Images

Quickly scan through previously saved image and video captures. This full field archive allows for quick image pull-up and the ability to sort and delete images no longer needed.

An **8GB SD card** is included with every system to transfer images and videos from system to remote PC for archiving, emailing, etc.



### Compare While Working

Upper Right-hand window features the **live video feed**, while all previously captured images are tiled around it.

This feature allows for real-time searching of previously captured good (or bad) examples for instant comparison.

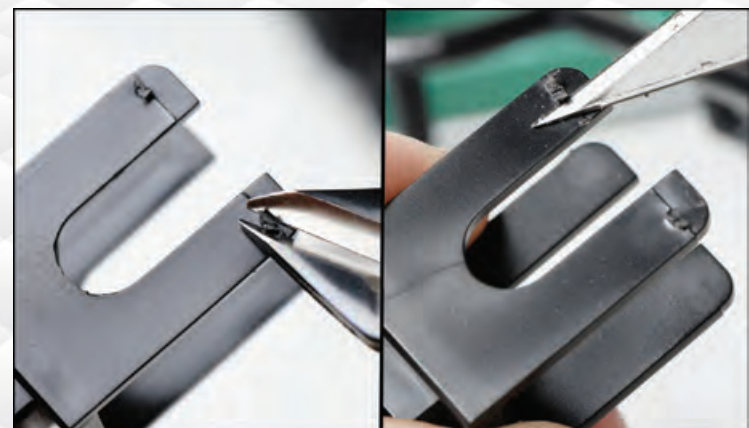

### Split Screen Viewing

Excellent training tool! Pull up a previously saved capture (left pane) and compare with live image on the right! This interactive screen is excellent for showcasing pass/fail to multiple people at once.

Ever have to train a group of new employees all at once? It has never been easier for all employees to see the same details, at the same time.

## Calibrated Onboard Measurement Couldn't Be Easier!

An Entire Array of Measurement Tools for High Precision, Repeatable Measurements. All Without Using a PC!



### Exclusive Features Found Only in Advanced Imaging & Measurement PC Suite

#### Extended Depth of Focus

This specialized tool allows for 'stacking' of multiple image captures taken at various focal lengths, into a single super clear image.

This tool is excellent for showcasing **super high clarity images** of tall items that are outside of the capabilities of optical clarity alone. No longer must you settle with images that are good enough... make them great!

#### Image Stitching

Inspecting something that is just too big to view all at once? This handy feature allows you to capture multiple images of the part, then 'stitch' them together digitally to **create a single extra-large image**. This technology is now available to you, with all of the quality you expect from O.C. White.

## Industry Standard Performance O.C. White Value

### ProZoom® 4.5 is the Industry Standard for High Precision and Long Service Life.

The ProZoom® 4.5 Stereo-Zoom Binocular Microscope family combines durability, low cost and performance. With magnification and performance on par with much more expensive microscopes, it can be adapted for most industrial needs.

- 7 - 45x Standard Magnification Range
- 3.5 - 225x Available with Options
- Extra Large 22mm 10x Eyepieces for Ergonomic Comfort
- .5x Objective Lens Included at No Charge (a \$125 VALUE)
- 90-250mm Working Distance
- ±5 Diopter Adjustable Eyepiece Tubes for Clarity
- Eyetube Inclination of 45°
- Easy 360° Main Body Rotation
- Built with ESD Safety Construction and Materials
- 5 Year Mechanical Warranty

**Our Most Popular** Standard in this system is our silky smooth precision-glide ball bearing arm base assembly, and our heavy duty weighted base.

Combining all of the optical features above with this rock solid base assembly and our **Micro-Lite® LED ring illuminator**... and you have a package that is perfectly suited for any inspection task. Built with ESD Safety Materials and Construction.



TKSZ-L-LV2

**Laboratory Base for Limited Space**  
This package is perfect for any user who has limited installation space, or does not require the vertical adjustability our other bases offer. 7-45x is standard and available with a choice of illuminators (shown with Micro-Lite® LED ring light). Built with ESD Safety Construction and Materials.



**Articulating Arm for Adjustable Height**  
This specialized articulating arm is great for customers who simply cannot mount a base anywhere on their worksurface (convenient table edge clamp mount), or that regularly inspect both very large and very small parts. Also available with choice of illuminators (shown with Micro-Lite® LED ring light). Built with ESD Safety Construction and Materials.

### ProZoom® 4.5 Technical Data

Eyepiece	Main Body	0.5X SZ-OB-050	0.75X SZ-OB-075	1X SZ-OB-100	1.5X SZ-OB-150	2X SZ-OB-200	
<b>10X</b>	MAG:	7-45X	3.5-22.5X	5.3-33.8X	7-45X	10.6-68X	14-90X
	FOV:	31.4-4.9mm	62.8-9.8mm	41.9-6.5mm	31.4-4.9mm	20.9-3.3mm	15.7-2.5mm
<b>15X</b>	MAG:	10.5-67.5X	5.3-33.8X	7.9-50.6X	10.5-67.5X	15.8-101.2X	21-135X
	FOV:	21.4-3.4mm	42.8-6.7mm	28.5-4.4mm	21.4-3.4mm	14.2-2.3mm	10.7-1.7mm
<b>20X</b>	MAG:	14-90X	7-45X	10.6-67.5X	14-90X	21.2-135X	28-180X
	FOV:	17.1-2.7mm	34.2-5.3mm	22.9-3.6mm	17.1-2.7mm	11.4-1.8mm	8.5-1.4mm
<b>25X</b>	MAG:	17.5-112.5X	8.8-56.3X	13.1-84.4X	17.5-112.5X	26.3-168.8X	35-225X
	FOV:	12.8-2mm	25.7-4mm	17.1-2.7mm	12.8-2mm	8.5-1.4mm	6.4-1mm
<b>Working Distance</b>		<b>88 mm</b>	<b>137 mm</b>	<b>103 mm</b>	<b>88 mm</b>	<b>38 mm</b>	<b>29 mm</b>

## Industry Standard Performance O.C. White Value

### ProZoom® 4.5 is the Industry Standard for High Precision and Long Service Life.

The ProZoom® 4.5 Stereo-Zoom Binocular Microscope family combines durability, low cost and performance. With magnification and performance on par with much more expensive microscopes, it can be adapted for most industrial needs.

- 7 - 45x Standard Magnification Range
- 3.5 - 225x Available with Options
- Extra Large 22mm 10x Eyepieces for Ergonomic Comfort
- .5x Objective Lens Included at No Charge (a \$125 VALUE)
- 90-250mm Working Distance
- ±5 Diopter Adjustable Eyepiece Tubes for Clarity
- Eyetube Inclination of 45°
- Easy 360° Main Body Rotation
- Built with ESD Safety Construction and Materials
- 5 Year Mechanical Warranty

**Our Most Popular** Standard in this system is our silky smooth precision-glide ball bearing arm base assembly, and our heavy duty weighted base.

Combining all of the optical features above with this rock solid base assembly and our **Micro-Lite® LED ring illuminator**... and you have a package that is perfectly suited for any inspection task. Built with ESD Safety Materials and Construction.



**Laboratory Base for Limited Space**  
This package is perfect for any user who has limited installation space, or does not require the vertical adjustability our other bases offer. 7-45x is standard and available with a choice of illuminators (shown with Micro-Lite® LED ring light). Built with ESD Safety Construction and Materials.



**Articulating Arm for Adjustable Height**  
This specialized articulating arm is great for customers who simply cannot mount a base anywhere on their worksurface (convenient table edge clamp mount), or that regularly inspect both very large and very small parts. Also available with choice of illuminators (shown with Micro-Lite® LED ring light). Built with ESD Safety Construction and Materials.

### ProZoom® 4.5 Technical Data

Eyepiece	Main Body	0.5X SZ-OB-050	0.75X SZ-OB-075	1X SZ-OB-100	1.5X SZ-OB-150	2X SZ-OB-200	
<b>10X</b>	MAG:	7-45X	3.5-22.5X	5.3-33.8X	7-45X	10.6-68X	14-90X
	FOV:	31.4-4.9mm	62.8-9.8mm	41.9-6.5mm	31.4-4.9mm	20.9-3.3mm	15.7-2.5mm
<b>15X</b>	MAG:	10.5-67.5X	5.3-33.8X	7.9-50.6X	10.5-67.5X	15.8-101.2X	21-135X
	FOV:	21.4-3.4mm	42.8-6.7mm	28.5-4.4mm	21.4-3.4mm	14.2-2.3mm	10.7-1.7mm
<b>20X</b>	MAG:	14-90X	7-45X	10.6-67.5X	14-90X	21.2-135X	28-180X
	FOV:	17.1-2.7mm	34.2-5.3mm	22.9-3.6mm	17.1-2.7mm	11.4-1.8mm	8.5-1.4mm
<b>25X</b>	MAG:	17.5-112.5X	8.8-56.3X	13.1-84.4X	17.5-112.5X	26.3-168.8X	35-225X
	FOV:	12.8-2mm	25.7-4mm	17.1-2.7mm	12.8-2mm	8.5-1.4mm	6.4-1mm
<b>Working Distance</b>		<b>88 mm</b>	<b>137 mm</b>	<b>103 mm</b>	<b>88 mm</b>	<b>38 mm</b>	<b>29 mm</b>

## Big Results Made Easy

### Next-Level Performance Meets Budget-Friendly Price

The ProZoom® 6.5 family outperforms stereo microscopes costing twice as much. ProZoom® 6.5 provides the **Largest Standard Working Distance**, the **Largest Magnification Range** and **Largest Eyepieces** available on modern stereo microscopes.

- 5 - 65x Standard Magnification Range (up to 390x w/options)
- Super Wide 28mm High Eye Point and Wide Field Eyepieces
- Eye-tube Inclination of 45° with 360° rotation of Main Body
- 190mm of Working Distance with 0.5x Objective Lens
- ±6 Diopter Adjustment Range
- Interpupillary Distance Adjustment on Eyepiece Tubes
- Built with ESD Safety Construction and Materials
- Trinocular Package includes 0.3x CCD adapter
- All Trinocular Packages include our 5MP Hybrid HDMI/USB camera with Advanced Onboard Imaging Controls
- Precision-glide Ball Bearing Arm Base Assembly
- 5 Year Mechanical Warranty (1 Year Electrical)

#### ProZoom® 6.5 Technical Data

Eyepiece	Main Body	0.37X	0.5X	0.7X	1.0X	2.0X	
		PZ-OB-037	PZ-OB-050	PZ-OB-070	PZ-OB-100	PZ-OB-200	
10X	MAG:	10-65X	3.7-24.1X	5-32.5X	7-46X	10-65X	20-130X
	FOV:	23-3.5mm	62.2-9.6mm	46-7mm	32.9-5mm	23-3.5mm	11.5-1.8mm
15X	MAG:	15-97.5X	5.55-36.1X	7.5-48.8X	10.5-69X	15-97.5X	30-195X
	FOV:	17-2.6mm	45.9-7.1mm	34-5.2mm	24.3-3.7mm	17-2.6mm	8.5-1.3mm
20X	MAG:	20-130X	7.4-48.1X	10-65X	14-92X	20-130X	40-260X
	FOV:	14-2.2mm	37.8-5.8mm	28-4.2mm	20-3.1mm	14-2.2mm	7-1.1mm
30X	MAG:	30-195X	11.1-72.2X	15-97.5X	21-138X	30-195X	60-390X
	FOV:	9-1.4mm	24.3-3.7mm	18-2.7mm	12.9-2mm	9.0-1.4mm	4.5-0.7mm
<b>Working Distance</b>	<b>110 mm</b>	<b>275 mm</b>	<b>195 mm</b>	<b>145 mm</b>	<b>110 mm</b>	<b>35 mm</b>	



#### PROZOOM® 6.5 TRINOCULAR STANDARD FEATURES

Each system ships with our exclusive **5MP Hybrid HDMI/USB Camera**. This exceptional smart camera pulls double duty for both production and quality assurance needs. It features both HDMI and USB outputs, and has integrated **smart camera controls** with a **host of onboard software features** including:



##### Image Capture

Quickly capture image and videos while inspecting **directly to the 8GB SD card**. Sort and archive to a PC.



##### Real Time Compare

Compare live video feed with previous captured images. Search and sort for **instant comparison**.



##### Calibrated Measure

An entire array of Measurement Tools for **high precision** and repeatable measurements without a PC!



##### Ultra-High Sensitivity

Industry leading low light sensitivity allows for crystal clear images where competitors cameras fail. **More sensitivity equals less light required...** which means less glare!

#### ADVANCED IMAGING & MEASUREMENT PC SUITE EXCLUSIVE FEATURES



##### Extended Depth of Focus

This specialized tool allows for 'stacking' of multiple image captures of tall objects taken at various focal lengths, into a single **super high clarity image**.



##### Image Stitching

Inspecting something that is just too big to view all at once? Capture multiple images of the object, then 'stitch' them together digitally to **create a single extra-large image**.

#### ProZoom® 6.5 Trinocular with Ultra-Cam II™



At the heart of every ProZoom® 6.5 trinocular system is our exclusive 5MP Hybrid HDMI/USB Camera with Onboard Image Controls. This system above includes microscope, base assembly, LED ring light, 5MP Hybrid HDMI/USB Camera as well as our **FREE HD2 Advanced Imaging & Measurement Software Suite** (a \$595 value)

#### ProZoom® 6.5 Trinocular with Ultra-Cam II™ & 22" LED Monitor



This system includes all of the features and benefits shown for the TKDPZT-LV2 system, but also includes a **22" HD LED screen**. We have matched the specifications of this screen to be the perfect companion to our 5MP Camera. Not all flat screens are created equal.

Also Available with 12" Integrated Screen! (TKPZT-HU-LV2)

## Big Results Made Easy

### Next-Level Performance Meets Budget-Friendly Price

The ProZoom® 6.5 family outperforms stereo microscopes costing twice as much. ProZoom® 6.5 provides the **Largest Standard Working Distance**, the **Largest Magnification Range** and **Largest Eyepieces** available on modern stereo microscopes.

- 5 - 65x Standard Magnification Range (up to 390x w/options)
- Super Wide 28mm High Eye Point and Wide Field Eyepieces
- Eye-tube Inclination of 45° with 360° rotation of Main Body
- 190mm of Working Distance with 0.5x Objective Lens
- ±6 Diopter Adjustment Range
- Interpupillary Distance Adjustment on Eyepiece Tubes
- Built with ESD Safety Construction and Materials
- Trinocular Package includes 0.3x CCD adapter
- All Trinocular Packages include our 5MP Hybrid HDMI/USB camera with Advanced Onboard Imaging Controls
- Precision-glide Ball Bearing Arm Base Assembly
- 5 Year Mechanical Warranty (1 Year Electrical)

#### ProZoom® 6.5 Technical Data

Eyepiece	Main Body	0.37X	0.5X	0.7X	1.0X	2.0X	
		PZ-OB-037	PZ-OB-050	PZ-OB-070	PZ-OB-100	PZ-OB-200	
10X	MAG:	10-65X	3.7-24.1X	5-32.5X	7-46X	10-65X	20-130X
	FOV:	23-3.5mm	62.2-9.6mm	46-7mm	32.9-5mm	23-3.5mm	11.5-1.8mm
15X	MAG:	15-97.5X	5.55-36.1X	7.5-48.8X	10.5-69X	15-97.5X	30-195X
	FOV:	17-2.6mm	45.9-7.1mm	34-5.2mm	24.3-3.7mm	17-2.6mm	8.5-1.3mm
20X	MAG:	20-130X	7.4-48.1X	10-65X	14-92X	20-130X	40-260X
	FOV:	14-2.2mm	37.8-5.8mm	28-4.2mm	20-3.1mm	14-2.2mm	7-1.1mm
30X	MAG:	30-195X	11.1-72.2X	15-97.5X	21-138X	30-195X	60-390X
	FOV:	9-1.4mm	24.3-3.7mm	18-2.7mm	12.9-2mm	9.0-1.4mm	4.5-0.7mm
<b>Working Distance</b>	<b>110 mm</b>	<b>275 mm</b>	<b>195 mm</b>	<b>145 mm</b>	<b>110 mm</b>	<b>35 mm</b>	



#### PROZOOM® 6.5 TRINOCULAR STANDARD FEATURES

Each system ships with our exclusive **5MP Hybrid HDMI/USB Camera**. This exceptional smart camera pulls double duty for both production and quality assurance needs. It features both HDMI and USB outputs, and has integrated **smart camera controls** with a **host of onboard software features** including:



##### Image Capture

Quickly capture image and videos while inspecting **directly to the 8GB SD card**. Sort and archive to a PC.



##### Real Time Compare

Compare live video feed with previous captured images. Search and sort for **instant comparison**.



##### Calibrated Measure

An entire array of Measurement Tools for **high precision** and repeatable measurements without a PC!



##### Ultra-High Sensitivity

Industry leading low light sensitivity allows for crystal clear images where competitors cameras fail. **More sensitivity equals less light required...** which means less glare!

#### ADVANCED IMAGING & MEASUREMENT PC SUITE EXCLUSIVE FEATURES



##### Extended Depth of Focus

This specialized tool allows for 'stacking' of multiple image captures of tall objects taken at various focal lengths, into a single **super high clarity image**.



##### Image Stitching

Inspecting something that is just too big to view all at once? Capture multiple images of the object, then 'stitch' them together digitally to **create a single extra-large image**.

#### ProZoom® 6.5 Trinocular with Ultra-Cam II™



At the heart of every ProZoom® 6.5 trinocular system is our exclusive 5MP Hybrid HDMI/USB Camera with Onboard Image Controls. This system above includes microscope, base assembly, LED ring light, 5MP Hybrid HDMI/USB Camera as well as our **FREE HD2 Advanced Imaging & Measurement Software Suite** (a \$595 value)

#### ProZoom® 6.5 Trinocular with Ultra-Cam II™ & 22" LED Monitor



This system includes all of the features and benefits shown for the TKDPZT-LV2 system, but also includes a **22" HD LED screen**. We have matched the specifications of this screen to be the perfect companion to our 5MP Camera. Not all flat screens are created equal.

Also Available with 12" Integrated Screen! (TKPZT-HU-LV2)

## Comfort is Our Main Objective

**Ergo-Zoom® Combines Comfort with the Highest Quality Image Possible from a Microscope!**



TKEZ-850-LV2

Ergo-Zoom® microscopes set a new standard for industry, offering scientific grade **Common Main Objective (CMO)** optical design at very attractive price points. This optical design delivers **distortion free, high resolution flat field** images. If you are inspecting mission-critical parts, there is no finer solution.

Ergonomic design includes **0-35° adjustable angle eyepiece**; neck fatigue and eye strain are a thing of the past! **Wide focus, large diameter 10x eyepieces** and **1x Auxiliary lenses** are included in standard packages.

Ergo-Zoom® is a **modular** microscope line which can grow with you, and be outfitted to match your exact needs. Your custom is our standard. It is available in three standard zoom tiers (8-50x, 8-65x, and 8-80x), and features detented zoom stops for repeatable magnification location. You can configure Ergo-Zoom® to reach **up to 320x!**

The **Precision Glide ball bearing arm** gives effortless motion with 20" of horizontal movement - and rock solid stability. Built for years of perfect use. All Ergo-Zoom® microscopes are built with **ESD Safety** in mind.

- 8-50x Standard Magnification Range
- Up to 320x with Options
- Wide focus, large diameter 10x eyepieces for all-day ergonomic comfort
- 32.5-200mm Working Distances (Based on Objective Lens)
- ±5 Diopter Adjustable Eyepiece Tubes for Clarity
- Eyetube Inclination of 0-35°
- Easy 360° Main Body Rotation
- ESD Safe
- Modular Designed System for expandable performance
- 5 Year Mechanical Warranty



**Full 35° Range of Motion!**  
Even at Maximum Magnification



TKDEZT-850-LV2

**Ergo-Zoom® 8-50x Trinocular with Ultra-Cam II™**  
This specialized system includes our world renowned Ergo-Zoom® 8-50x optics, **trinocular splitter assembly**, .5x CCD adapter and our new and exclusive **5MP Hybrid HDMI/USB Camera with Onboard Image Controls**. This system also includes our **FREE HD2 Advanced Imaging & Measurement software suite** (a \$595 value).

**THE ONBOARD IMAGE CONTROLS INCLUDE:**



### Ergo-Zoom® 8-50x Trinocular with Ultra-Cam II™ & 22" LED Monitor

This system includes all of the features and benefits shown for the TKDEZT-850-LV2 system, but also includes a **22" HD LED screen**. We have matched the specifications of this screen to be the **perfect companion to our 5MP Camera**. Not all flat screens are created equal, and when pairing with the world's finest microscope optics, this is not an area where you want second-best.



TKEZT-850-LV2

### PLAN APO LENSES ARE THE KEY TO CRITICAL QUALITY INSPECTION

EZ-OB-050



EZ-OB-100



EZ-OB-200



EZ-Dual Splitter



#### Ergo-Zoom® EZ-850 Technical Data

Eyepiece	EZ-OB-050A (.5x Achromatic)	EZ-OB-050 (.5x Plan APO)	EZ-OB-100 (1x Std. in Kit)	EZ-OB-200 (2x Plan APO)
<b>10X</b>	MAG: 4-25X FOV: 60-9.6mm	4-25X 60-9.6mm	8-50X 30-4.8mm	16-100X 15-2.4mm
<b>15X</b>	MAG: 6-37.5X FOV: 40-6.4mm	6-37.5X 40-6.4mm	12-75X 20-3.2mm	24-150X 10-1.6mm
<b>20X</b>	MAG: 8-50X FOV: 30-4.8mm	8-50X 30-4.8mm	16-100X 15-2.4mm	32-200X 7.5-1.2mm
<b>Working Distance</b>	<b>200 mm</b>	<b>126 mm</b>	<b>78 mm</b>	<b>32.5 mm</b>

#### THERE'S MORE ONLINE!

For complete optical data on all three Ergo-Zoom® microscope models including accessories, please visit:

[www.ocwhite.com](http://www.ocwhite.com)

## Comfort is Our Main Objective

**Ergo-Zoom® Combines Comfort with the Highest Quality Image Possible from a Microscope!**



Ergo-Zoom® microscopes set a new standard for industry, offering scientific grade **Common Main Objective (CMO)** optical design at very attractive price points. This optical design delivers **distortion free, high resolution flat field** images. If you are inspecting mission-critical parts, there is no finer solution.

Ergonomic design includes **0-35° adjustable angle eyepiece**; neck fatigue and eye strain are a thing of the past! **Wide focus, large diameter 10x eyepieces** and **1x Auxiliary lenses** are included in standard packages.

Ergo-Zoom® is a **modular** microscope line which can grow with you, and be outfitted to match your exact needs. Your custom is our standard. It is available in three standard zoom tiers (8-50x, 8-65x, and 8-80x), and features detented zoom stops for repeatable magnification location. You can configure Ergo-Zoom® to reach **up to 320x!**

The **Precision Glide ball bearing arm** gives effortless motion with 20" of horizontal movement - and rock solid stability. Built for years of perfect use. All Ergo-Zoom® microscopes are built with **ESD Safety** in mind.

- 8-50x Standard Magnification Range
- Up to 320x with Options
- Wide focus, large diameter 10x eyepieces for all-day ergonomic comfort
- 32.5-200mm Working Distances (Based on Objective Lens)
- ±5 Diopter Adjustable Eyepiece Tubes for Clarity
- Eyetube Inclination of 45°
- Easy 360° Main Body Rotation
- ESD Safe
- Modular Designed System for expandable performance
- 5 Year Mechanical Warranty



**Ergo-Zoom® 8-50x Trinocular with Ultra-Cam II™**  
This specialized system includes our world renowned Ergo-Zoom® 8-50x optics, **trinocular splitter assembly**, .5x CCD adapter and our new and exclusive **5MP Hybrid HDMI/USB Camera with Onboard Image Controls**. This system also includes our **FREE HD2 Advanced Imaging & Measurement software suite** (a \$595 value).

**THE ONBOARD IMAGE CONTROLS INCLUDE:**



### Ergo-Zoom® 8-50x Trinocular with Ultra-Cam II™ & 22" LED Monitor

This system includes all of the features and benefits shown for the TKDEZT-850-LV2 system, but also includes a **22" HD LED screen**. We have matched the specifications of this screen to be the **perfect companion to our 5MP Camera**. Not all flat screens are created equal, and when pairing with the world's finest microscope optics, this is not an area where you want second-best.

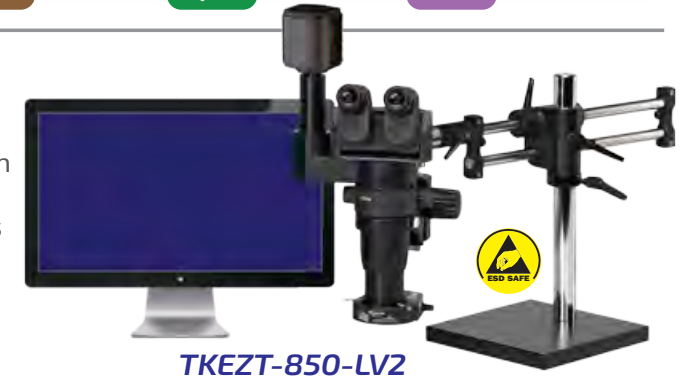

### PLAN APO LENSES ARE THE KEY TO CRITICAL QUALITY INSPECTION

**EZ-OB-050**

**EZ-OB-100**

**EZ-OB-200**

**EZ-Dual Splitter**



#### Ergo-Zoom® EZ-850 Technical Data

Eyepiece	EZ-OB-050A (.5x Achromatic)	EZ-OB-050 (.5x Plan APO)	EZ-OB-100 (1x Std. in Kit)	EZ-OB-200 (2x Plan APO)
<b>10X</b>	MAG: 4-25X FOV: 60-9.6mm	4-25X 60-9.6mm	8-50X 30-4.8mm	16-100X 15-2.4mm
<b>15X</b>	MAG: 6-37.5X FOV: 40-6.4mm	6-37.5X 40-6.4mm	12-75X 20-3.2mm	24-150X 10-1.6mm
<b>20X</b>	MAG: 8-50X FOV: 30-4.8mm	8-50X 30-4.8mm	16-100X 15-2.4mm	32-200X 7.5-1.2mm
<b>Working Distance</b>	<b>200 mm</b>	<b>126 mm</b>	<b>78 mm</b>	<b>32.5 mm</b>

#### THERE'S MORE ONLINE!

For complete optical data on all three Ergo-Zoom® microscope models including accessories, please visit:

[www.ocwhite.com](http://www.ocwhite.com)

# LED Microscope Lighting for Worldwide Use

## Micro-Lite® Illuminators Repel Static Charges, Surpassing the Most Stringent ESD Specifications!

Featuring a long life span, low operating costs and high output, our LV2000 solves the three key problems in microscope illumination. It's ESD safe construction contains new surface mounted LED technology providing dimmable 5700K light with no hotspots, low power consumption, "instant-on" startup and zero desktop footprint. This is the world's best LED illuminator.

- Special ANTI-STATIC polymer repels any static build up.
- 2.35" (60mm) mounting ring diameter, with optional 66mm now available
- 9 LED surface mount array with exclusive thermal management system
- 5700K Color Temperature Standard
- New Optional 3500K Color Temperature Available (LV3500 and LV3500-B)
- Brighter than a 150w Halogen above 6" height
- Exclusive larger and more even illuminated area - no hotspots from change in working distance
- Dimmable, flicker-free light from 100-5%
- No bulky desktop controller box
- 100-240v (50/60hz) auto switchable power supply with worldwide approvals
- Fits most microscopes with optional adapters
- 5 Year/50,000 Hour warranty

Perfect, Dimmable White Light  
Adjustable 100-5% of ideal 5700K light!

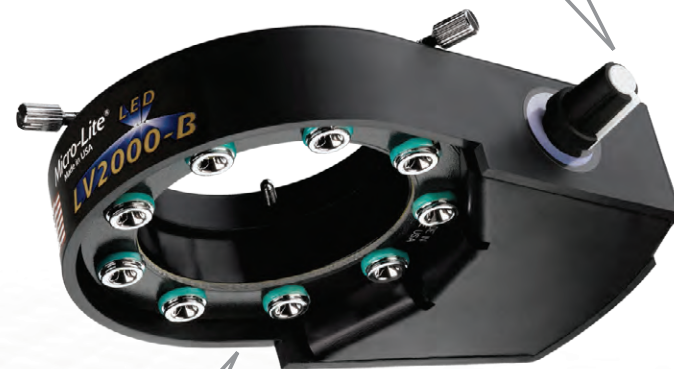

LV2000-B

No Hotspots  
Produces even lighting at any working distance!



Fits Most Popular Microscopes on the Market Today!!



## Micro-Lite® High Intensity 5700k LED Ring Illuminator

LV2000-B



Micro-Lite® High Intensity 5700k LED Ring Illuminator with 9 Extreme Output LEDs. This LED Illuminator is the brightest on the market, and rivals 150w Halogen illuminators! Energy Efficient with 5700K Color Temperature. Total Energy consumption of this unit is a scant 8w! Features a 100-240V (50/60Hz) Auto Switchable Transformer design. Available in black or white molded shades. ESD Safe.

## Micro-Lite® High Intensity 3500k LED Ring Illuminator

LV3500



Micro-Lite® High Intensity LED Ring Illuminator with 3500K color temperature. This LED Illuminator is the brightest on the market, and rivals 150w Halogen illuminators in it's specific yellow hue. An excellent choice for medical device manufacturers. Total Energy consumption of this unit is a scant 8w! Features a 100-240V (50/60Hz) Auto Switchable Transformer design. Available in black or white molded shades. ESD Safe.

## SPECIALIZED ULTRAVIOLET LED LIGHTING

### Micro-Lite® Ultraviolet (395nm) LED Ring Illuminator

Micro-Lite® High Intensity Black Ultraviolet LED Ring Illuminator with 9 Extreme Output LEDs. At Home in Many Industries, Our UV2000-B Features 395nm Ultraviolet Light (365nm available).

Specialized Market Applications Include:

- Conformal Coating
- Dye Penetrant Inspection
- Forgery Analysis
- Mineral & Gemstone Inspection
- Crime Scene Forensics
- Homeland Security



UV2000-B

# LED Microscope Lighting for Worldwide Use

## Micro-Lite® Illuminators Repel Static Charges, Surpassing the Most Stringent ESD Specifications!

Featuring a long life span, low operating costs and high output, our LV2000 solves the three key problems in microscope illumination. It's ESD safe construction contains new surface mounted LED technology providing dimmable 5700K light with no hotspots, low power consumption, "instant-on" startup and zero desktop footprint. This is the world's best LED illuminator.

- Special ANTI-STATIC polymer repels any static build up.
- 2.35" (60mm) mounting ring diameter, with optional 66mm now available
- 9 LED surface mount array with exclusive thermal management system
- 5700K Color Temperature Standard
- New Optional 3500K Color Temperature Available (LV3500 and LV3500-B)
- Brighter than a 150w Halogen above 6" height
- Exclusive larger and more even illuminated area - no hotspots from change in working distance
- Dimmable, flicker-free light from 100-5%
- No bulky desktop controller box
- 100-240v (50/60hz) auto switchable power supply with worldwide approvals
- Fits most microscopes with optional adapters
- 5 Year/50,000 Hour warranty

Perfect, Dimmable White Light  
Adjustable 100-5% of ideal 5700K light!

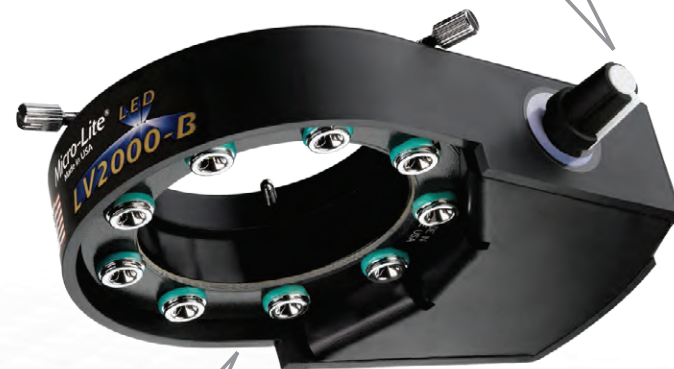

LV2000-B

No Hotspots  
Produces even lighting at any working distance!



Fits Most Popular Microscopes on the Market Today!!



## Micro-Lite® High Intensity 5700k LED Ring Illuminator

LV2000-B



Micro-Lite® High Intensity 5700k LED Ring Illuminator with 9 Extreme Output LEDs. This LED Illuminator is the brightest on the market, and rivals 150w Halogen illuminators! Energy Efficient with 5700K Color Temperature. Total Energy consumption of this unit is a scant 8w! Features a 100-240V (50/60Hz) Auto Switchable Transformer design. Available in black or white molded shades. ESD Safe.

## Micro-Lite® High Intensity 3500k LED Ring Illuminator

LV3500



Micro-Lite® High Intensity LED Ring Illuminator with 3500K color temperature. This LED Illuminator is the brightest on the market, and rivals 150w Halogen illuminators in it's specific yellow hue. An excellent choice for medical device manufacturers. Total Energy consumption of this unit is a scant 8w! Features a 100-240V (50/60Hz) Auto Switchable Transformer design. Available in black or white molded shades. ESD Safe.

## SPECIALIZED ULTRAVIOLET LED LIGHTING

### Micro-Lite® Ultraviolet (395nm) LED Ring Illuminator

Micro-Lite® High Intensity Black Ultraviolet LED Ring Illuminator with 9 Extreme Output LEDs. At Home in Many Industries, Our UV2000-B Features 395nm Ultraviolet Light (365nm available).

Specialized Market Applications Include:

- Conformal Coating
- Dye Penetrant Inspection
- Forgery Analysis
- Mineral & Gemstone Inspection
- Crime Scene Forensics
- Homeland Security



UV2000-B

## Flicker-Free Fluorescent

Patented Ballast Technology Can Even Be Used with Cameras – No Rolling Image!

### Micro-Lite® High/Low Ring Illuminator

FL1000



Micro-Lite® High/Low Fluorescent Ring Illuminator is the highest quality fluorescent ring on the market. The exclusive 'flicker-free' design makes for fatigue free usage. Our specialized ballast technology eliminates flickering that can cause eye fatigue, and allows for more lumen output per watt used. This is in a class all its own. 60mm ID (66mm available), with a whole host of adapters available. **ESD Safe**

### Micro-Lite® Fully Variable Ring Illuminator

FV1000

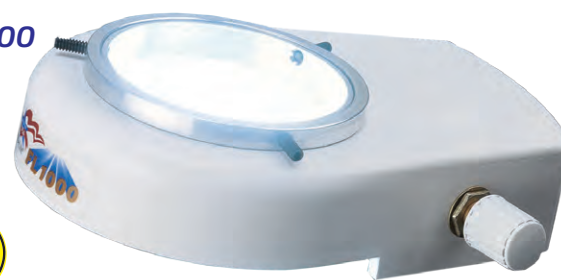

Micro-Lite® Fully Variable Fluorescent Ring Illuminator offers exclusive dimming control, as well as flicker-free performance. Dimming range from 100-20%. The same ballast technology as our FL1000, zero flicker and highest lumen output per watt in the industry, this illuminator can work with almost any microscope on the market today. 60mm ID (66mm available). **ESD Safe**

### MICRO-LITE® HIGH QUALITY REPLACEMENT BULBS

FL150

Deluxe White



FL200

Ultraviolet (365nm)



FL320

3200° Kelvin



FL400

150w EKE



FL500

Deep Red (658nm)



FL700

Deep Green (544nm)



FL600

Deep Tri-Band Blue (450nm)



16517

Replaces Stocker & Yale #973-510B



### MICRO-LITE® 150W FIBER OPTIC ILLUMINATORS

FL3000-A



We offer three distinct fiber optic styles; annular ring, dual gooseneck, and new backlit stage. We offer numerous annular ring sizes, for lighting of various diameter lens systems.

The key to our success with the FL3000 series is not singular... the devil is in the details. Included standard on all Micro-Lite® Fiber Optic illuminators is an internal IR filter. This retains all heat to the power box, and allows cool, bright light to enter the fiber optic cable. The solid state design of the FL3000 series also provides up to **45% more light** than the competition.

The FL3000 is overbuilt, to stand up to years of use and abuse. Our annular ring light guides are machined for an **extremely slim profile**, to allow for maximum working distance when mounted underneath a microscope.

FL3000-D



One of the unique features of the FL3000 series is our Fully Variable Intensity Control. Our specialized circuitry features a 'rolling start' transformer. What this means, is that instead of being able to turn the light onto high intensity from the start, which greatly degrades the bulb and component life, the FL3000 circuits have a millisecond voltage ramp up, which **greatly extends the life** of the components and bulbs.

- ESD Safe and RoHS Compliant
- Many Different Nosepiece Diameters Available (.192" - .998")
- Intense, cool, bright light due to the internal IR filter
- Cool, solid state design with 45% more light
- Extremely slim profile of annular light guide for maximum working distance
- Dual Gooseneck Includes (2) Focusable Lenses
- Aluminum and Steel Construction for Years of Use and Abuse
- Silent fan provides quiet, vibration free operation
- Solid State Operation - no rheostats to heat up and fail
- Optional color filter kit (#CFK-3)
- 1 Year Electrical Warranty

FL3000-BL



## Flicker-Free Fluorescent

Patented Ballast Technology Can Even Be Used with Cameras – No Rolling Image!

### Micro-Lite® High/Low Ring Illuminator

FL1000



Micro-Lite® High/Low Fluorescent Ring Illuminator is the highest quality fluorescent ring on the market. The exclusive 'flicker-free' design makes for fatigue free usage. Our specialized ballast technology eliminates flickering that can cause eye fatigue, and allows for more lumen output per watt used. This is in a class all its own. 60mm ID (66mm available), with a whole host of adapters available. **ESD Safe**

### Micro-Lite® Fully Variable Ring Illuminator

FV1000



Micro-Lite® Fully Variable Fluorescent Ring Illuminator offers exclusive dimming control, as well as flicker-free performance. Dimming range from 100-20%. The same ballast technology as our FL1000, zero flicker and highest lumen output per watt in the industry, this illuminator can work with almost any microscope on the market today. 60mm ID (66mm available). **ESD Safe**

### MICRO-LITE® HIGH QUALITY REPLACEMENT BULBS



### MICRO-LITE® 150W FIBER OPTIC ILLUMINATORS

FL3000-A



We offer three distinct fiber optic styles; annular ring, dual gooseneck, and new backlit stage. We offer numerous annular ring sizes, for lighting of various diameter lens systems.

The key to our success with the FL3000 series is not singular... the devil is in the details. Included standard on all Micro-Lite® Fiber Optic illuminators is an internal IR filter. This retains all heat to the power box, and allows cool, bright light to enter the fiber optic cable. The solid state design of the FL3000 series also provides up to **45% more light** than the competition.

The FL3000 is overbuilt, to stand up to years of use and abuse. Our annular ring light guides are machined for an **extremely slim profile**, to allow for maximum working distance when mounted underneath a microscope.

FL3000-D



One of the unique features of the FL3000 series is our Fully Variable Intensity Control. Our specialized circuitry features a 'rolling start' transformer. What this means, is that instead of being able to turn the light onto high intensity from the start, which greatly degrades the bulb and component life, the FL3000 circuits have a millisecond voltage ramp up, which **greatly extends the life** of the components and bulbs.

- ESD Safe and RoHS Compliant
- Many Different Nosepiece Diameters Available (.192" - .998")
- Intense, cool, bright light due to the internal IR filter
- Cool, solid state design with 45% more light
- Extremely slim profile of annular light guide for maximum working distance
- Dual Gooseneck Includes (2) Focusable Lenses
- Aluminum and Steel Construction for Years of Use and Abuse
- Silent fan provides quiet, vibration free operation
- Solid State Operation - no rheostats to heat up and fail
- Optional color filter kit (#CFK-3)
- 1 Year Electrical Warranty



FL3000-BL











## Looking for pricing, stock, or lifecycle information?

Click below to explore more details on WIN SOURCE:

-  [View FL1000 on WIN SOURCE](#)
-  [O.C. White Co. Information](#)

## Optimize Your Supply Chain with WIN SOURCE Solutions

-  Global Sourcing Solution
-  Obsolete Management
-  Cost Control Management
-  Shortage Management
-  Alternative Solution
-  Excess Inventory Management