



**THE DATASHEET OF
TXS0104EQRUTRQ1**



TXS0104E-Q1 Automotive 4-Bit Bidirectional Voltage-Level Translator for Open-Drain and Push-Pull Applications

1 Features

- Qualified for automotive applications
- AEC-Q100 qualified with the following results:
 - Device temperature grade 1: -40°C to $+125^{\circ}\text{C}$ ambient operating temperature range
 - Device HBM ESD Classification Level 2
 - Device CDM ESD Classification Level C6
- No direction-control signal required
- Maximum data rates:
 - 24 Mbps maximum (push pull)
 - 2 Mbps (open drain)
- 1.65 V to 3.6 V on A port and 2.3 V to 5.5 V on B port ($V_{CCA} \leq V_{CCB}$)
- No power-supply sequencing required— V_{CCA} or V_{CCB} can be ramped first
- ESD protection exceeds JESD 22:
 - A Port
 - 2000-V Human-Body Model (A114-B)
 - 1000-V Charged-Device Model (C101)
 - B Port
 - 15-kV Human-Body Model (A114-B)
 - 1000-V Charged-Device Model (C101)
- IEC 61000-4-2 ESD (B port)
 - ± 8 -kV Contact Discharge
 - ± 10 -kV Air-Gap Discharge

2 Applications

- [Automotive infotainment, advance driver assistance systems \(ADAS\)](#)
- Isolates and level translates between main processor and peripheral modules
- I²C or 1-wire voltage-level translation

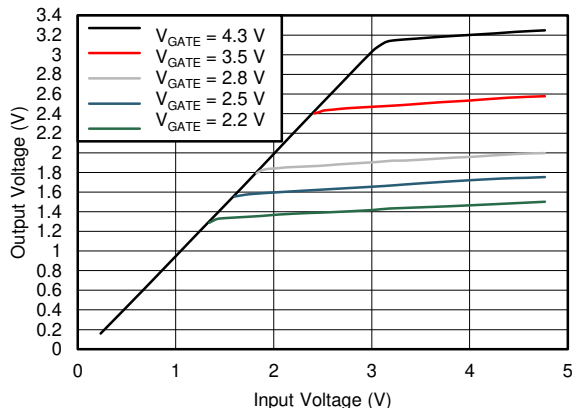

Transfer Characteristics of an N-Channel Transistor

3 Description

The TXS0104E-Q1 device connects an incompatible logic communication from chip-to-chip due to voltage mismatch. This auto-direction translator can be conveniently used to bridge the gap without the need of direction control from the host. Each channel can be mixed and matched with different output types (open-drain or push-pull) and mixed data flows (transmit or receive) without intervention from the host. This 4-bit noninverting translator uses two separate configurable power-supply rails. The A and B ports are designed to track V_{CCA} and V_{CCB} respectively. The V_{CCB} pin accepts any supply voltage from 2.3 V to 5.5 V while the V_{CCA} pin accepts any supply voltage from 1.65 V to 3.6 V such that V_{CCA} is less than or equal to V_{CCB} . This tracking allows for low-voltage bidirectional translation between any of the 1.8-V, 2.5-V, 3.3-V, and 5-V voltage nodes.

When the output-enable (OE) input is low, all outputs are placed in the high-impedance state.

The TXS0104E-Q1 device is designed so that the OE input circuit is supplied by V_{CCA} .

To be in the high-impedance state during power up or power down, the OE pin must be tied to the GND pin through a pull down resistor; the minimum value of the resistor is determined by the current-sourcing capability of the driver.

Package Information

PART NUMBER	PACKAGE ⁽¹⁾	PACKAGE SIZE ⁽²⁾
TXS0104E-Q1	PW (TSSOP, 14)	5 mm × 6.4 mm
	BQA (WQFN, 14)	3 mm × 2.5 mm
	RUT (UQFN, 12)	2 mm × 1.7 mm

- (1) For all available packages, see the orderable addendum at the end of the data sheet.
- (2) The package size (length × width) is a nominal value and includes pins, where applicable.



Table of Contents

1 Features	1	7 Detailed Description	16
2 Applications	1	7.1 Overview.....	16
3 Description	1	7.2 Functional Block Diagram.....	16
4 Pin Configuration and Functions	3	7.3 Feature Description.....	17
5 Specifications	5	7.4 Device Functional Modes.....	17
5.1 Absolute Maximum Ratings.....	5	8 Application and Implementation	18
5.2 ESD Ratings.....	5	8.1 Application Information.....	18
5.3 Recommended Operating Conditions.....	5	8.2 Typical Application.....	18
5.4 Thermal Information.....	6	8.3 Power Supply Recommendations.....	19
5.5 Electrical Characteristics.....	6	8.4 Layout.....	20
5.6 Timing Requirements— $V_{CCA} = 1.8\text{ V} \pm 0.15\text{ V}$	7	9 Device and Documentation Support	21
5.7 Timing Requirements— $V_{CCA} = 2.5\text{ V} \pm 0.2\text{ V}$	7	9.1 Documentation Support.....	21
5.8 Timing Requirements— $V_{CCA} = 3.3\text{ V} \pm 0.3\text{ V}$	7	9.2 Receiving Notification of Documentation Updates.....	21
5.9 Switching Characteristics— $V_{CCA} = 1.8\text{ V} \pm 0.15\text{ V}$	8	9.3 Support Resources.....	21
5.10 Switching Characteristics— $V_{CCA} = 2.5\text{ V} \pm 0.2\text{ V}$...	10	9.4 Trademarks.....	21
5.11 Switching Characteristics— $V_{CCA} = 3.3\text{ V} \pm 0.3\text{ V}$...	12	10 Electrostatic Discharge Caution	21
5.12 Typical Characteristics.....	13	11 Glossary	21
6 Parameter Measurement Information	14	12 Revision History	21
6.1 Load Circuits.....	14	13 Mechanical, Packaging, and Orderable Information	22
6.2 Voltage Waveforms.....	15		

4 Pin Configuration and Functions

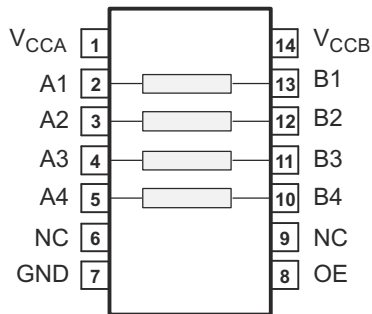

NC - No internal connection

Figure 4-1. PW Package, 14-Pin TSSOP (Top View)

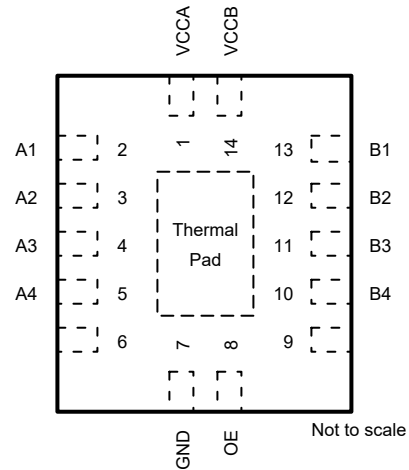

NC - No internal connection

Figure 4-2. BQA Package, 14-Pin WQFN (Top View)

Table 4-1. Pin Functions

PIN		TYPE ⁽¹⁾	DESCRIPTION
NAME	NO.		
A1	2	I/O	Input-output 1 for the A port. This pin is referenced to V_{CCA} .
A2	3	I/O	Input-output 2 for the A port. This pin is referenced to V_{CCA} .
A3	4	I/O	Input-output 3 for the A port. This pin is referenced to V_{CCA} .
A4	5	I/O	Input-output 4 for the A port. This pin is referenced to V_{CCA} .
B1	13	I/O	Input-output 1 for the B port. This pin is referenced to V_{CCB} .
B2	12	I/O	Input-output 2 for the B port. This pin is referenced to V_{CCB} .
B3	11	I/O	Input-output 3 for the B port. This pin is referenced to V_{CCB} .
B4	10	I/O	Input-output 4 for the B port. This pin is referenced to V_{CCB} .
GND	7	—	Ground
NC	6	—	No connection
	9		
OE	8	I	Tri-state output-mode enable. Pull the OE pin low to place all outputs in tri-state mode. This pin is referenced to V_{CCA} .
V_{CCA}	1	I	A-port supply voltage. $1.65\text{ V} \leq V_{CCA} \leq 3.6\text{ V}$ and $V_{CCA} \leq V_{CCB}$.
V_{CCB}	14	I	B-port supply voltage. $2.3\text{ V} \leq V_{CCB} \leq 5.5\text{ V}$.

(1) I = input, O = output

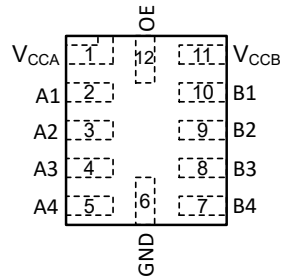

Figure 4-3. RUT Package, 12-Pin UQFN (Transparent Top View)

Table 4-2. Pin Functions: RUT

PIN		TYPE ⁽¹⁾	DESCRIPTION
NAME	NO.		
A1	2	I/O	Input/output A1. Referenced to V_{CCA} .
A2	3	I/O	Input/output A2. Referenced to V_{CCA} .
A3	4	I/O	Input/output A3. Referenced to V_{CCA} .
A4	5	I/O	Input/output A4. Referenced to V_{CCA} .
B1	10	I/O	Input/output B1. Referenced to V_{CCB} .
B2	9	I/O	Input/output B2. Referenced to V_{CCB} .
B3	8	I/O	Input/output B3. Referenced to V_{CCB} .
B4	7	I/O	Input/output B4. Referenced to V_{CCB} .
GND	6	—	Ground
OE	12	I	3-state output-mode enable. Pull OE low to place all outputs in 3-state mode. Referenced to V_{CCA} .
V_{CCA}	1	—	A-port supply voltage. $1.65\text{ V} \leq V_{CCA} \leq 3.6\text{ V}$ and $V_{CCA} \leq V_{CCB}$.
V_{CCB}	11	—	A-port supply voltage. $1.65\text{ V} \leq V_{CCA} \leq 3.6\text{ V}$ and $V_{CCA} \leq V_{CCB}$.

(1) I = input, O = output

5 Specifications

5.1 Absolute Maximum Ratings

over operating free-air temperature range (unless otherwise noted)⁽¹⁾

			MIN	MAX	UNIT	
Supply voltage	V_{CCA}		-0.5	4.6	V	
	V_{CCB}		-0.5	6.5		
Input-output pin voltage, V_{IO} ⁽²⁾	A1, A2, A3, A4	A port	-0.5	4.6	V	
	B1, B2, B3, B4	B port	-0.5	6.5		
Output voltage, V_O	Voltage range applied to any output in the high-impedance or power-off state ⁽²⁾	A port	-0.5	4.6	V	
		B port	-0.5	6.5		
	Voltage range applied to any output in the high or low state ^{(2) (3)}	A port	-0.5	$V_{CCA} + 0.5$	V	
		B port	-0.5	$V_{CCB} + 0.5$		
Input clamp current, I_{IK}		$V_I < 0$		-50	mA	
Output clamp current, I_{OK}		$V_O < 0$		-50	mA	
Continuous output current, I_O				±50	mA	
Continuous current through each V_{CCA} , V_{CCB} , or GND				±100	mA	
Storage temperature range, T_{stg}				-65	150	°C

- (1) Stresses beyond those listed under *absolute maximum ratings* may cause permanent damage to the device. These are stress ratings only, and functional operation of the device at these or any other conditions beyond those indicated under *recommended operating conditions* is not implied. Exposure to absolute-maximum-rated conditions for extended periods may affect device reliability.
- (2) The input and output negative-voltage ratings may be exceeded if the input and output current ratings are observed.
- (3) The value of V_{CCA} and V_{CCB} are provided in the recommended operating conditions table.

5.2 ESD Ratings

		VALUE	UNIT
$V_{(ESD)}$ Electrostatic discharge	Human-body model (HBM), per AEC Q100-002 ⁽¹⁾	±2500	V
	Charged-device model (CDM), per AEC Q100-011	±1500	

- (1) AEC Q100-002 indicates that HBM stressing shall be in accordance with the ANSI/ESDA/JEDEC JS-001 specification.

5.3 Recommended Operating Conditions

over operating free-air temperature range (unless otherwise noted)

			V_{CCA}	V_{CCB}	MIN	MAX	UNIT
V_{CCA}	Supply voltage ⁽¹⁾				1.65	3.6	V
V_{CCB}	Supply voltage ⁽¹⁾				2.3	5.5	
$V_{IH(Ax)}$	High-level input voltage	A-port I/Os	1.65 to 1.95 V	2.3 to 5.5 V	$V_{CCA} - 0.2$	V_{CCA}	V
			2.3 to 3.6 V		$V_{CCA} - 0.4$	V_{CCA}	
$V_{IH(Bx)}$	High-level input voltage	B-port I/Os	1.65 to 3.6 V	2.3 to 5.5 V	$V_{CCB} - 0.4$	V_{CCB}	
$V_{IH(OE)}$	High-level input voltage	OE input			$V_{CCA} \times 0.65$	5.5	
$V_{IL(Ax)}$	Low-level input voltage	A-port I/Os	1.65 to 3.6 V	2.3 to 5.5 V	0	0.15	V
$V_{IL(Bx)}$	Low-level input voltage	B-port I/Os			0	0.15	
$V_{IL(OE)}$	Low-level input voltage	OE input			0	$V_{CCA} \times 0.35$	
$\Delta t/\Delta V_{(Ax)}$	Input transition rise or fall rate	A-port I/Os, push-pull driving			1.65 to 3.6 V	2.3 to 5.5 V	
$\Delta t/\Delta V_{(Bx)}$	Input transition rise or fall rate	B-port I/Os, push-pull driving		10			
$\Delta t/\Delta V_{(OE)}$	Input transition rise or fall rate	OE input		10			
T_A	Operating free-air temperature				-40	125	°C

- (1) V_{CCA} must be less than or equal to V_{CCB} , and V_{CCA} must not exceed 3.6 V.

5.4 Thermal Information

over operating free-air temperature range (unless otherwise noted) ⁽¹⁾

THERMAL METRIC ⁽¹⁾		TXS0104E-Q1			UNIT
		PW (TSSOP)	BQA (WQFN)	RUT (UQFN)	
		14 PINS	14 PINS	12 PINS	
R _{θJA}	Junction-to-ambient thermal resistance	115.2	73.5	150.4	°C/W
R _{θJC(top)}	Junction-to-case (top) thermal resistance	46.2	76.9	68.6	°C/W
R _{θJB}	Junction-to-board thermal resistance	70.9	43.0	76.3	°C/W
ψ _{JT}	Junction-to-top characterization parameter	3.4	4.7	2.4	°C/W
ψ _{JB}	Junction-to-board characterization parameter	70.2	42.9	76.2	°C/W
R _{θJC(bot)}	Junction-to-case (bottom) thermal resistance	—	19.6	—	°C/W

(1) For more information about traditional and new thermal metrics, see the [Semiconductor and IC Package Thermal Metrics](#) application report.

5.5 Electrical Characteristics

over recommended operating free-air temperature range (unless otherwise noted) ⁽¹⁾

PARAMETER	TEST CONDITIONS	V _{CCA}	V _{CCB}	MIN	TYP	MAX	UNIT
V _{OH(Ax)}	High-level output voltage, A port I _{OH} = -20 μA, V _{I(Bx)} ≥ V _{CCB} - 0.4 V	1.65 to 3.6 V	2.3 to 5.5 V	V _{CCA} × 0.75			V
V _{OL(Ax)}	Low-level output voltage, A port I _{OL} = 1 mA, V _{I(Bx)} ≤ 0.15 V	1.65 to 3.6 V	2.3 to 5.5 V	0.4			V
V _{OH(Bx)}	High-level output voltage, B port I _{OH} = -20 μA, V _{I(Ax)} ≥ V _{CCA} - 0.2 V	1.65 to 3.6 V	2.3 to 5.5 V	V _{CCB} × 0.75			V
V _{OL(Bx)}	Low-level output voltage, B port I _{OL} = 1 mA, V _{I(Ax)} ≤ 0.15 V	1.65 to 3.6 V	2.3 to 5.5 V	0.4			V
I _{I(OE)}	V _I = V _{CCI} or GND	1.65 to 3.6 V	2.3 to 5.5 V	±2			μA
	V _I = V _{CCI} or GND, T _A = 25°C			±1			
I _{OZ}	OE = V _{IL}	1.65 to 3.6 V	2.3 to 5.5 V	±3			μA
	OE = V _{IL} , T _A = 25°C			±1			
I _{CCA}	V _I = V _O = Open, I _O = 0	1.65 to V _{CCB}	2.3 to 5.5 V	4			μA
		3.6 V	0	2.2			
		0	5.5 V	-1			
I _{CCB}	V _I = V _O = Open, I _O = 0	1.65 to V _{CCB}	2.3 to 5.5 V	21			μA
		3.6 V	0	-1			
		0	5.5 V	5			
I _{CCA} +I _{CCB}	V _I = V _O = Open, I _O = 0	1.65 V to V _{CCB}	2.3 to 5.5 V	25			μA
C _{I(OE)}	T _A = 25°C	3.3 V	3.3 V	4			pF
				2.5			
C _{IO(Ax)}	T _A = 25°C	3.3 V	3.3 V	6.5			pF
				5			
C _{IO(Bx)}	T _A = 25°C	3.3 V	3.3 V	16.5			
				12			

(1) V_{CCA} must be less than or equal to V_{CCB}, and V_{CCA} must not exceed 3.6 V.

5.6 Timing Requirements— $V_{CCA} = 1.8\text{ V} \pm 0.15\text{ V}$

over recommended operating free-air temperature range (unless otherwise noted)

			MIN	MAX	UNIT
Data rate	Push-pull driving	$V_{CCB} = 2.5\text{ V} \pm 0.2\text{ V}$		18	Mbps
		$V_{CCB} = 3.3\text{ V} \pm 0.3\text{ V}$		21	
		$V_{CCB} = 5\text{ V} \pm 0.5\text{ V}$		23	
	Open-drain driving	$V_{CCB} = 2.5\text{ V} \pm 0.2\text{ V}$		2	
		$V_{CCB} = 3.3\text{ V} \pm 0.3\text{ V}$		2	
		$V_{CCB} = 5\text{ V} \pm 0.5\text{ V}$		2	
t_w Pulse duration, data inputs See Figure 6-4	Push-pull driving	$V_{CCB} = 2.5\text{ V} \pm 0.2\text{ V}$	55		ns
		$V_{CCB} = 3.3\text{ V} \pm 0.3\text{ V}$	47		
		$V_{CCB} = 5\text{ V} \pm 0.5\text{ V}$	43		
	Open-drain driving	$V_{CCB} = 2.5\text{ V} \pm 0.2\text{ V}$	500		
		$V_{CCB} = 3.3\text{ V} \pm 0.3\text{ V}$	500		
		$V_{CCB} = 5\text{ V} \pm 0.5\text{ V}$	500		

5.7 Timing Requirements— $V_{CCA} = 2.5\text{ V} \pm 0.2\text{ V}$

over recommended operating free-air temperature range (unless otherwise noted)

			MIN	MAX	UNIT
Data rate	Push-pull driving	$V_{CCB} = 2.5\text{ V} \pm 0.2\text{ V}$		20	Mbps
		$V_{CCB} = 3.3\text{ V} \pm 0.3\text{ V}$		22	
		$V_{CCB} = 5\text{ V} \pm 0.5\text{ V}$		24	
	Open-drain driving	$V_{CCB} = 2.5\text{ V} \pm 0.2\text{ V}$		2	
		$V_{CCB} = 3.3\text{ V} \pm 0.3\text{ V}$		2	
		$V_{CCB} = 5\text{ V} \pm 0.5\text{ V}$		2	
t_w Pulse duration, data inputs See Figure 6-4	Push-pull driving	$V_{CCB} = 2.5\text{ V} \pm 0.2\text{ V}$	50		ns
		$V_{CCB} = 3.3\text{ V} \pm 0.3\text{ V}$	45		
		$V_{CCB} = 5\text{ V} \pm 0.5\text{ V}$	41		
	Open-drain driving	$V_{CCB} = 2.5\text{ V} \pm 0.2\text{ V}$	500		
		$V_{CCB} = 3.3\text{ V} \pm 0.3\text{ V}$	500		
		$V_{CCB} = 5\text{ V} \pm 0.5\text{ V}$	500		

5.8 Timing Requirements— $V_{CCA} = 3.3\text{ V} \pm 0.3\text{ V}$

over recommended operating free-air temperature range (unless otherwise noted)

			MIN	MAX	UNIT
Data rate	Push-pull driving	$V_{CCB} = 3.3\text{ V} \pm 0.3\text{ V}$		22	Mbps
		$V_{CCB} = 5\text{ V} \pm 0.5\text{ V}$		24	
	Open-drain driving	$V_{CCB} = 3.3\text{ V} \pm 0.3\text{ V}$		2	
		$V_{CCB} = 5\text{ V} \pm 0.5\text{ V}$		2	
t_w Pulse duration, Data inputs See Figure 6-4	Push-pull driving	$V_{CCB} = 3.3\text{ V} \pm 0.3\text{ V}$	45		ns
		$V_{CCB} = 5\text{ V} \pm 0.5\text{ V}$	41		
	Open-drain driving	$V_{CCB} = 3.3\text{ V} \pm 0.3\text{ V}$	500		
		$V_{CCB} = 5\text{ V} \pm 0.5\text{ V}$	500		

5.9 Switching Characteristics— $V_{CCA} = 1.8\text{ V} \pm 0.15\text{ V}$

over recommended operating free-air temperature range (unless otherwise noted)

PARAMETER		TEST CONDITIONS		MIN	MAX	UNIT
$t_{PHL(A-B)}$	Propagation delay time (high to low), from A (input) to B (output) See Figure 6-5	Push-pull driving	$V_{CCB} = 2.5\text{ V} \pm 0.2\text{ V}$		6	ns
			$V_{CCB} = 3.3\text{ V} \pm 0.3\text{ V}$		5.8	
			$V_{CCB} = 5\text{ V} \pm 0.5\text{ V}$		5.8	
		Open-drain driving	$V_{CCB} = 2.5\text{ V} \pm 0.2\text{ V}$		8.8	
			$V_{CCB} = 3.3\text{ V} \pm 0.3\text{ V}$		9.6	
			$V_{CCB} = 5\text{ V} \pm 0.5\text{ V}$		10	
$t_{PHL(B-A)}$	Propagation delay time (high to low), from B (input) to A (output) See Figure 6-5	Push-pull driving	$V_{CCB} = 2.5\text{ V} \pm 0.2\text{ V}$		4.4	ns
			$V_{CCB} = 3.3\text{ V} \pm 0.3\text{ V}$		4.5	
			$V_{CCB} = 5\text{ V} \pm 0.5\text{ V}$		4.7	
		Open-drain driving	$V_{CCB} = 2.5\text{ V} \pm 0.2\text{ V}$		5.3	
			$V_{CCB} = 3.3\text{ V} \pm 0.3\text{ V}$		4.4	
			$V_{CCB} = 5\text{ V} \pm 0.5\text{ V}$		4	
$t_{PLH(A-B)}$	Propagation delay time (low to high), from A (input) to B (output) See Figure 6-5	Push-pull driving	$V_{CCB} = 2.5\text{ V} \pm 0.2\text{ V}$		7.7	ns
			$V_{CCB} = 3.3\text{ V} \pm 0.3\text{ V}$		6.8	
			$V_{CCB} = 5\text{ V} \pm 0.5\text{ V}$		7	
		Open-drain driving	$V_{CCB} = 2.5\text{ V} \pm 0.2\text{ V}$		50	
			$V_{CCB} = 3.3\text{ V} \pm 0.3\text{ V}$		26	
			$V_{CCB} = 5\text{ V} \pm 0.5\text{ V}$		33	
$t_{PLH(B-A)}$	Propagation delay time (low to high), from B (input) to A (output) See Figure 6-5	Push-pull driving	$V_{CCB} = 2.5\text{ V} \pm 0.2\text{ V}$		5.3	ns
			$V_{CCB} = 3.3\text{ V} \pm 0.3\text{ V}$		4.5	
			$V_{CCB} = 5\text{ V} \pm 0.5\text{ V}$		0.5	
		Open-drain driving	$V_{CCB} = 2.5\text{ V} \pm 0.2\text{ V}$		36	
			$V_{CCB} = 3.3\text{ V} \pm 0.3\text{ V}$		16	
			$V_{CCB} = 5\text{ V} \pm 0.5\text{ V}$		20	
$t_{en(OE-A)}$ $t_{en(OE-B)}$	Enable time, from OE (input) to A or B (output)	$V_{CCB} = 2.5\text{ V} \pm 0.2\text{ V}$			200	ns
		$V_{CCB} = 3.3\text{ V} \pm 0.3\text{ V}$			200	
		$V_{CCB} = 5\text{ V} \pm 0.5\text{ V}$			200	
$t_{dis(OE-A)}$ $t_{dis(OE-B)}$	Disable time, from OE (input) to A or B (output)	$V_{CCB} = 2.5\text{ V} \pm 0.2\text{ V}$			200	ns
		$V_{CCB} = 3.3\text{ V} \pm 0.3\text{ V}$			200	
		$V_{CCB} = 5\text{ V} \pm 0.5\text{ V}$			200	
$t_{r(Ax)}$	Rise time, A port	Push-pull driving	$V_{CCB} = 2.5\text{ V} \pm 0.2\text{ V}$		9.5	ns
			$V_{CCB} = 3.3\text{ V} \pm 0.3\text{ V}$		9.3	
			$V_{CCB} = 5\text{ V} \pm 0.5\text{ V}$		15	
		Open-drain driving	$V_{CCB} = 2.5\text{ V} \pm 0.2\text{ V}$	38	199	
			$V_{CCB} = 3.3\text{ V} \pm 0.3\text{ V}$	30	150	
			$V_{CCB} = 5\text{ V} \pm 0.5\text{ V}$	22	109	
$t_{r(Bx)}$	Rise time, B port	Push-pull driving	$V_{CCB} = 2.5\text{ V} \pm 0.2\text{ V}$		10.8	ns
			$V_{CCB} = 3.3\text{ V} \pm 0.3\text{ V}$		9.1	
			$V_{CCB} = 5\text{ V} \pm 0.5\text{ V}$		7.6	
		Open-drain driving	$V_{CCB} = 2.5\text{ V} \pm 0.2\text{ V}$	34	186	
			$V_{CCB} = 3.3\text{ V} \pm 0.3\text{ V}$	23	112	
			$V_{CCB} = 5\text{ V} \pm 0.5\text{ V}$	10	58	

5.9 Switching Characteristics— $V_{CCA} = 1.8\text{ V} \pm 0.15\text{ V}$ (continued)

over recommended operating free-air temperature range (unless otherwise noted)

PARAMETER		TEST CONDITIONS		MIN	MAX	UNIT
$t_{f(Ax)}$	Fall time, A port	Push-pull driving	$V_{CCB} = 2.5\text{ V} \pm 0.2\text{ V}$		5.9	ns
			$V_{CCB} = 3.3\text{ V} \pm 0.3\text{ V}$		6	
			$V_{CCB} = 5\text{ V} \pm 0.5\text{ V}$		13.3	
	Open-drain driving	$V_{CCB} = 2.5\text{ V} \pm 0.2\text{ V}$		6.9		
		$V_{CCB} = 3.3\text{ V} \pm 0.3\text{ V}$		6.4		
		$V_{CCB} = 5\text{ V} \pm 0.5\text{ V}$		6.1		
$t_{f(Bx)}$	Fall time, B port	Push-pull driving	$V_{CCB} = 2.5\text{ V} \pm 0.2\text{ V}$		7.6	ns
			$V_{CCB} = 3.3\text{ V} \pm 0.3\text{ V}$		7.5	
			$V_{CCB} = 5\text{ V} \pm 0.5\text{ V}$		8.8	
	Open-drain driving	$V_{CCB} = 2.5\text{ V} \pm 0.2\text{ V}$		13.8		
		$V_{CCB} = 3.3\text{ V} \pm 0.3\text{ V}$		16.2		
		$V_{CCB} = 5\text{ V} \pm 0.5\text{ V}$		16.2		
t_{sk}	Channel-to-channel skew	$V_{CCB} = 2.5\text{ V} \pm 0.2\text{ V}$			1	ns
		$V_{CCB} = 3.3\text{ V} \pm 0.3\text{ V}$			1	
		$V_{CCB} = 5\text{ V} \pm 0.5\text{ V}$			1	
Maximum data rate	Push-pull driving	$V_{CCB} = 2.5\text{ V} \pm 0.2\text{ V}$			18	Mbps
		$V_{CCB} = 3.3\text{ V} \pm 0.3\text{ V}$			21	
		$V_{CCB} = 5\text{ V} \pm 0.5\text{ V}$			23	
	Open-drain driving	$V_{CCB} = 2.5\text{ V} \pm 0.2\text{ V}$			2	
		$V_{CCB} = 3.3\text{ V} \pm 0.3\text{ V}$			2	
		$V_{CCB} = 5\text{ V} \pm 0.5\text{ V}$			2	

5.10 Switching Characteristics— $V_{CCA} = 2.5\text{ V} \pm 0.2\text{ V}$

over recommended operating free-air temperature range (unless otherwise noted)

PARAMETER		TEST CONDITIONS		MIN	MAX	UNIT
$t_{PHL(A-B)}$	Propagation delay time (high to low), from A (input) to B (output) See Figure 6-5	Push-pull driving	$V_{CCB} = 2.5\text{ V} \pm 0.2\text{ V}$		3.2	ns
			$V_{CCB} = 3.3\text{ V} \pm 0.3\text{ V}$		3.3	
			$V_{CCB} = 5\text{ V} \pm 0.5\text{ V}$		3.4	
		Open-drain driving	$V_{CCB} = 2.5\text{ V} \pm 0.2\text{ V}$		6.3	
			$V_{CCB} = 3.3\text{ V} \pm 0.3\text{ V}$		6	
			$V_{CCB} = 5\text{ V} \pm 0.5\text{ V}$		5.8	
$t_{PHL(B-A)}$	Propagation delay time (high to low), from B (input) to A (output) See Figure 6-5	Push-pull driving	$V_{CCB} = 2.5\text{ V} \pm 0.2\text{ V}$		3	ns
			$V_{CCB} = 3.3\text{ V} \pm 0.3\text{ V}$		3.6	
			$V_{CCB} = 5\text{ V} \pm 0.5\text{ V}$		4.3	
		Open-drain driving	$V_{CCB} = 2.5\text{ V} \pm 0.2\text{ V}$		4.7	
			$V_{CCB} = 3.3\text{ V} \pm 0.3\text{ V}$		4.2	
			$V_{CCB} = 5\text{ V} \pm 0.5\text{ V}$		4	
$t_{PLH(A-B)}$	Propagation delay time (low to high), from A (input) to B (output) See Figure 6-5	Push-pull driving	$V_{CCB} = 2.5\text{ V} \pm 0.2\text{ V}$		3.5	ns
			$V_{CCB} = 3.3\text{ V} \pm 0.3\text{ V}$		4.1	
			$V_{CCB} = 5\text{ V} \pm 0.5\text{ V}$		4.4	
		Open-drain driving	$V_{CCB} = 2.5\text{ V} \pm 0.2\text{ V}$		3.5	
			$V_{CCB} = 3.3\text{ V} \pm 0.3\text{ V}$		4.1	
			$V_{CCB} = 5\text{ V} \pm 0.5\text{ V}$		4.4	
$t_{PLH(B-A)}$	Propagation delay time (low to high), from B (input) to A (output) See Figure 6-5	Push-pull driving	$V_{CCB} = 2.5\text{ V} \pm 0.2\text{ V}$		2.5	ns
			$V_{CCB} = 3.3\text{ V} \pm 0.3\text{ V}$		1.6	
			$V_{CCB} = 5\text{ V} \pm 0.5\text{ V}$		0.7	
		Open-drain driving	$V_{CCB} = 2.5\text{ V} \pm 0.2\text{ V}$		2.5	
			$V_{CCB} = 3.3\text{ V} \pm 0.3\text{ V}$		1.6	
			$V_{CCB} = 5\text{ V} \pm 0.5\text{ V}$		1	
$t_{en(OE-A)}$ $t_{en(OE-B)}$	Enable time, from OE (input) to A or B (output)	$V_{CCB} = 2.5\text{ V} \pm 0.2\text{ V}$			200	ns
		$V_{CCB} = 3.3\text{ V} \pm 0.3\text{ V}$			200	
		$V_{CCB} = 5\text{ V} \pm 0.5\text{ V}$			200	
$t_{dis(OE-A)}$ $t_{dis(OE-B)}$	Disable time, from OE (input) to A or B (output)	$V_{CCB} = 2.5\text{ V} \pm 0.2\text{ V}$			200	ns
		$V_{CCB} = 3.3\text{ V} \pm 0.3\text{ V}$			200	
		$V_{CCB} = 5\text{ V} \pm 0.5\text{ V}$			200	
$t_{r(Ax)}$	Rise time, A port	Push-pull driving	$V_{CCB} = 2.5\text{ V} \pm 0.2\text{ V}$		7.4	ns
			$V_{CCB} = 3.3\text{ V} \pm 0.3\text{ V}$		6.6	
			$V_{CCB} = 5\text{ V} \pm 0.5\text{ V}$		5.6	
		Open-drain driving	$V_{CCB} = 2.5\text{ V} \pm 0.2\text{ V}$	34	180	
			$V_{CCB} = 3.3\text{ V} \pm 0.3\text{ V}$	28	150	
			$V_{CCB} = 5\text{ V} \pm 0.5\text{ V}$	24	105	
$t_{r(Bx)}$	Rise time, B port	Push-pull driving	$V_{CCB} = 2.5\text{ V} \pm 0.2\text{ V}$		8.3	ns
			$V_{CCB} = 3.3\text{ V} \pm 0.3\text{ V}$		7.2	
			$V_{CCB} = 5\text{ V} \pm 0.5\text{ V}$		6.1	
		Open-drain driving	$V_{CCB} = 2.5\text{ V} \pm 0.2\text{ V}$	35	170	
			$V_{CCB} = 3.3\text{ V} \pm 0.3\text{ V}$	24	120	
			$V_{CCB} = 5\text{ V} \pm 0.5\text{ V}$	12	64	
$t_{f(Ax)}$	Fall time, A port	Push-pull driving	$V_{CCB} = 2.5\text{ V} \pm 0.2\text{ V}$		5.7	ns
			$V_{CCB} = 3.3\text{ V} \pm 0.3\text{ V}$		5.5	
			$V_{CCB} = 5\text{ V} \pm 0.5\text{ V}$		5.3	
		Open-drain driving	$V_{CCB} = 2.5\text{ V} \pm 0.2\text{ V}$			
			$V_{CCB} = 3.3\text{ V} \pm 0.3\text{ V}$			
			$V_{CCB} = 5\text{ V} \pm 0.5\text{ V}$		5.8	

5.10 Switching Characteristics— $V_{CCA} = 2.5\text{ V} \pm 0.2\text{ V}$ (continued)

over recommended operating free-air temperature range (unless otherwise noted)

PARAMETER		TEST CONDITIONS		MIN	MAX	UNIT
$t_{f(Bx)}$	Fall time, B port	Push-pull driving	$V_{CCB} = 2.5\text{ V} \pm 0.2\text{ V}$		7.8	ns
			$V_{CCB} = 3.3\text{ V} \pm 0.3\text{ V}$		6.7	
			$V_{CCB} = 5\text{ V} \pm 0.5\text{ V}$		6.6	
	Open-drain driving	$V_{CCB} = 2.5\text{ V} \pm 0.2\text{ V}$		8.8		
		$V_{CCB} = 3.3\text{ V} \pm 0.3\text{ V}$		9.4		
		$V_{CCB} = 5\text{ V} \pm 0.5\text{ V}$		10.4		
t_{sk}	Channel-to-channel skew	$V_{CCB} = 2.5\text{ V} \pm 0.2\text{ V}$			1	ns
		$V_{CCB} = 3.3\text{ V} \pm 0.3\text{ V}$			1	
		$V_{CCB} = 5\text{ V} \pm 0.5\text{ V}$			1	
Maximum data rate	Push-pull driving	$V_{CCB} = 2.5\text{ V} \pm 0.2\text{ V}$		20		Mbps
		$V_{CCB} = 3.3\text{ V} \pm 0.3\text{ V}$		22		
		$V_{CCB} = 5\text{ V} \pm 0.5\text{ V}$		24		
	Open-drain driving	$V_{CCB} = 2.5\text{ V} \pm 0.2\text{ V}$		2		
		$V_{CCB} = 3.3\text{ V} \pm 0.3\text{ V}$		2		
		$V_{CCB} = 5\text{ V} \pm 0.5\text{ V}$		2		

5.11 Switching Characteristics— $V_{CCA} = 3.3\text{ V} \pm 0.3\text{ V}$

over recommended operating free-air temperature range (unless otherwise noted)

PARAMETER		TEST CONDITIONS		MIN	MAX	UNIT	
$t_{PHL(A-B)}$	Propagation delay time (high to low), from A (input) to B (output) See Figure 6-5	Push-pull driving	$V_{CCB} = 3.3\text{ V} \pm 0.3\text{ V}$		2.4	ns	
			$V_{CCB} = 5\text{ V} \pm 0.5\text{ V}$		3.1		
		Open-drain driving	$V_{CCB} = 3.3\text{ V} \pm 0.3\text{ V}$		4.2		
			$V_{CCB} = 5\text{ V} \pm 0.5\text{ V}$		4.6		
$t_{PHL(B-A)}$	Propagation delay time (high to low), from B (input) to A (output) See Figure 6-5	Push-pull driving	$V_{CCB} = 3.3\text{ V} \pm 0.3\text{ V}$		2.5		
			$V_{CCB} = 5\text{ V} \pm 0.5\text{ V}$		3.3		
		Open-drain driving	$V_{CCB} = 3.3\text{ V} \pm 0.3\text{ V}$		124		
			$V_{CCB} = 5\text{ V} \pm 0.5\text{ V}$		97		
$t_{PLH(A-B)}$	Propagation delay time (low to high), from A (input) to B (output) See Figure 6-5	Push-pull driving	$V_{CCB} = 3.3\text{ V} \pm 0.3\text{ V}$		4.2	ns	
			$V_{CCB} = 5\text{ V} \pm 0.5\text{ V}$		4.4		
		Open-drain driving	$V_{CCB} = 3.3\text{ V} \pm 0.3\text{ V}$		4.2		
			$V_{CCB} = 5\text{ V} \pm 0.5\text{ V}$		4.4		
$t_{PLH(B-A)}$	Propagation delay time (low to high), from B (input) to A (output) See Figure 6-5	Push-pull driving	$V_{CCB} = 3.3\text{ V} \pm 0.3\text{ V}$		2.5		
			$V_{CCB} = 5\text{ V} \pm 0.5\text{ V}$		2.6		
		Open-drain driving	$V_{CCB} = 3.3\text{ V} \pm 0.3\text{ V}$		2.5		
			$V_{CCB} = 5\text{ V} \pm 0.5\text{ V}$		3.3		
$t_{en(OE-A)}$	Enable time, from OE (input) to A or B (output)	$V_{CCB} = 3.3\text{ V} \pm 0.3\text{ V}$			200	ns	
$t_{en(OE-B)}$		$V_{CCB} = 5\text{ V} \pm 0.5\text{ V}$			200		
$t_{dis(OE-A)}$	Disable time, from OE (input) to A or B (output)	$V_{CCB} = 3.3\text{ V} \pm 0.3\text{ V}$			200	ns	
$t_{dis(OE-B)}$		$V_{CCB} = 5\text{ V} \pm 0.5\text{ V}$			200		
$t_{r(Ax)}$	Rise time, A port	Push-pull driving	$V_{CCB} = 3.3\text{ V} \pm 0.3\text{ V}$		5.6	ns	
			$V_{CCB} = 5\text{ V} \pm 0.5\text{ V}$		5		
		Open-drain driving	$V_{CCB} = 3.3\text{ V} \pm 0.3\text{ V}$	25	140		
			$V_{CCB} = 5\text{ V} \pm 0.5\text{ V}$	19	102		
$t_{r(Bx)}$	Rise time, B port	Push-pull driving	$V_{CCB} = 3.3\text{ V} \pm 0.3\text{ V}$		6.4		ns
			$V_{CCB} = 5\text{ V} \pm 0.5\text{ V}$		7.4		
		Open-drain driving	$V_{CCB} = 3.3\text{ V} \pm 0.3\text{ V}$	26	130		
			$V_{CCB} = 5\text{ V} \pm 0.5\text{ V}$	14	75		
$t_{f(Ax)}$	Fall time, A port	Push-pull driving	$V_{CCB} = 3.3\text{ V} \pm 0.3\text{ V}$		5.4	ns	
			$V_{CCB} = 5\text{ V} \pm 0.5\text{ V}$		5		
		Open-drain driving	$V_{CCB} = 3.3\text{ V} \pm 0.3\text{ V}$		6.1		
			$V_{CCB} = 5\text{ V} \pm 0.5\text{ V}$		5.7		
$t_{f(Bx)}$	Fall time, B port	Push-pull driving	$V_{CCB} = 3.3\text{ V} \pm 0.3\text{ V}$		7.4		ns
			$V_{CCB} = 5\text{ V} \pm 0.5\text{ V}$		7.6		
		Open-drain driving	$V_{CCB} = 3.3\text{ V} \pm 0.3\text{ V}$		7.6		
			$V_{CCB} = 5\text{ V} \pm 0.5\text{ V}$		8.3		
t_{sk}	Channel-to-channel skew	$V_{CCB} = 3.3\text{ V} \pm 0.3\text{ V}$			1	ns	
		$V_{CCB} = 5\text{ V} \pm 0.5\text{ V}$			1		
Maximum data rate		Push-pull driving	$V_{CCB} = 3.3\text{ V} \pm 0.3\text{ V}$	22		Mbps	
			$V_{CCB} = 5\text{ V} \pm 0.5\text{ V}$	24			
		Open-drain driving	$V_{CCB} = 3.3\text{ V} \pm 0.3\text{ V}$	2			
			$V_{CCB} = 5\text{ V} \pm 0.5\text{ V}$	2			

5.12 Typical Characteristics

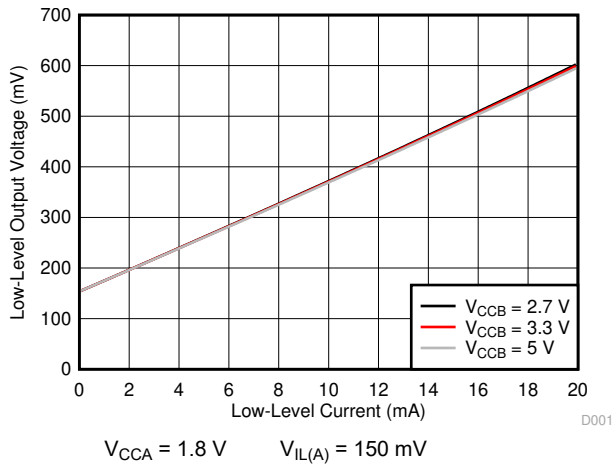

Figure 5-1. Low-Level Output Voltage ($V_{OL(Ax)}$) vs Low-Level Current ($I_{OL(Ax)}$)

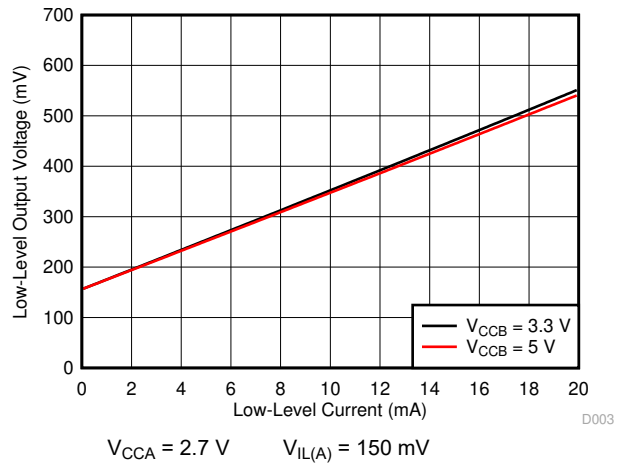

Figure 5-2. Low-Level Output Voltage ($V_{OL(Ax)}$) vs Low-Level Current ($I_{OL(Ax)}$)

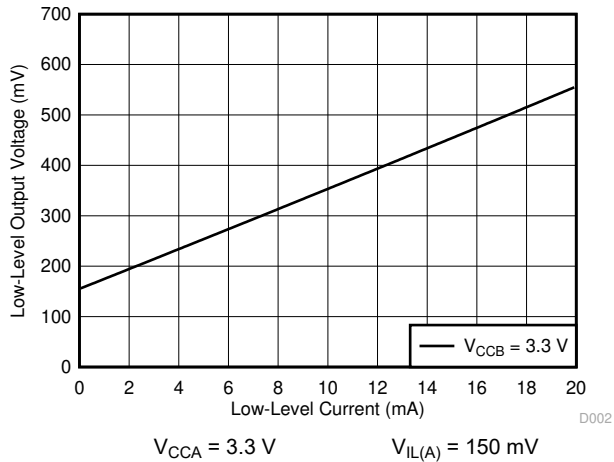

Figure 5-3. Low-Level Output Voltage ($V_{OL(Ax)}$) vs Low-Level Current ($I_{OL(Ax)}$)

6 Parameter Measurement Information

6.1 Load Circuits

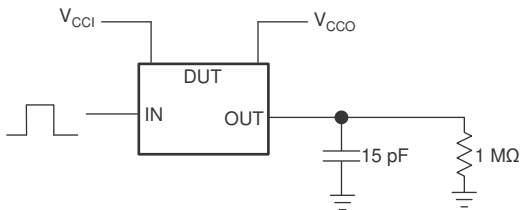

Figure 6-1. Data Rate, Pulse Duration, Propagation Delay, Output Rise-Time and Fall-Time Measurement Using a Push-Pull Driver

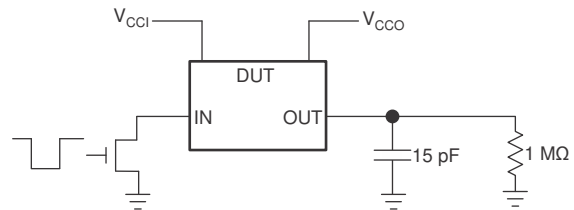
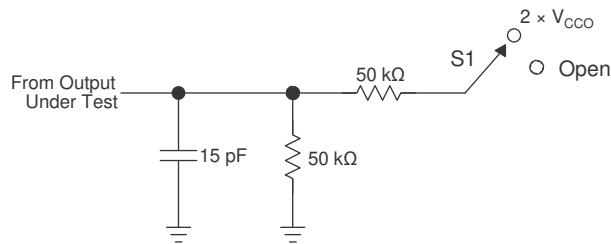

Figure 6-2. Data Rate, Pulse Duration, Propagation Delay, Output Rise-Time and Fall-Time Measurement Using an Open-Drain Driver



TEST	S1
t_{PZL} / t_{PLZ} (t_{dis})	$2 \times V_{CCO}$
t_{PHZ} / t_{PZH} (t_{en})	Open

Figure 6-3. Load Circuit for Enable-Time and Disable-Time Measurement

1. t_{PLZ} and t_{PHZ} are the same as t_{dis} .
2. t_{PZL} and t_{PZH} are the same as t_{en} .
3. V_{CCI} is the V_{CC} associated with the input port.
4. V_{CCO} is the V_{CC} associated with the output port.

6.2 Voltage Waveforms

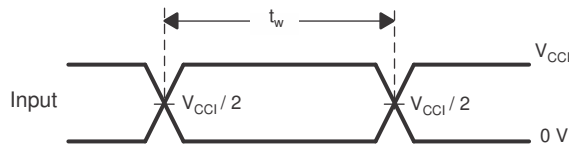

Figure 6-4. Pulse Duration

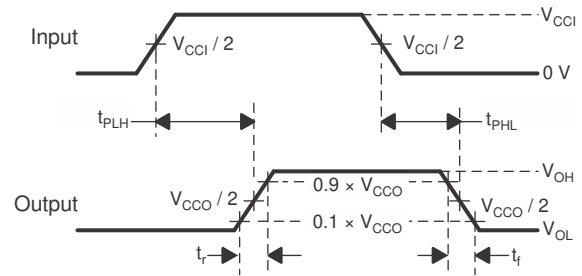
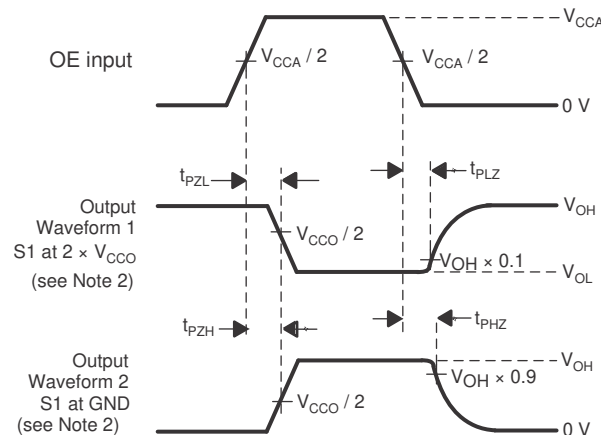

Figure 6-5. Propagation Delay Times



1. C_L includes probe and jig capacitance.
2. Waveform 1 in Figure 6-6 is for an output with internal such that the output is high, except when OE is high (see Figure 6-3). Waveform 2 in Figure 6-6 is for an output with conditions such that the output is low, except when OE is high.
3. All input pulses are supplied by generators having the following characteristics: $PRR \leq 10$ MHz, $Z_O = 50 \Omega$, $dv/dt \geq 1$ V/ns.
4. The outputs are measured one at a time, with one transition per measurement.
5. t_{PLZ} and t_{PHZ} are the same as t_{dis} .
6. t_{PZL} and t_{PZH} are the same as t_{en} .
7. t_{PLH} and t_{PHL} are the same as t_{pd} .
8. V_{CCI} is the V_{CC} associated with the input port.
9. V_{CCO} is the V_{CC} associated with the output port.

Figure 6-6. Enable and Disable Times

7 Detailed Description

7.1 Overview

The TXS0104E-Q1 device is a directionless voltage-level translator specifically designed for translating logic voltage levels. The A port is able to accept I/O voltages ranging from 1.65 V to 3.6 V, while the B port can accept I/O voltages from 2.3 V to 5.5 V. The device is a pass gate architecture with edge rate accelerators (one shots) to improve the overall data rate. 10-k Ω pullup resistors, commonly used in open drain applications, have been conveniently integrated so that an external resistor is not needed. While this device is designed for open drain applications, the device can also translate push-pull CMOS logic outputs.

7.2 Functional Block Diagram

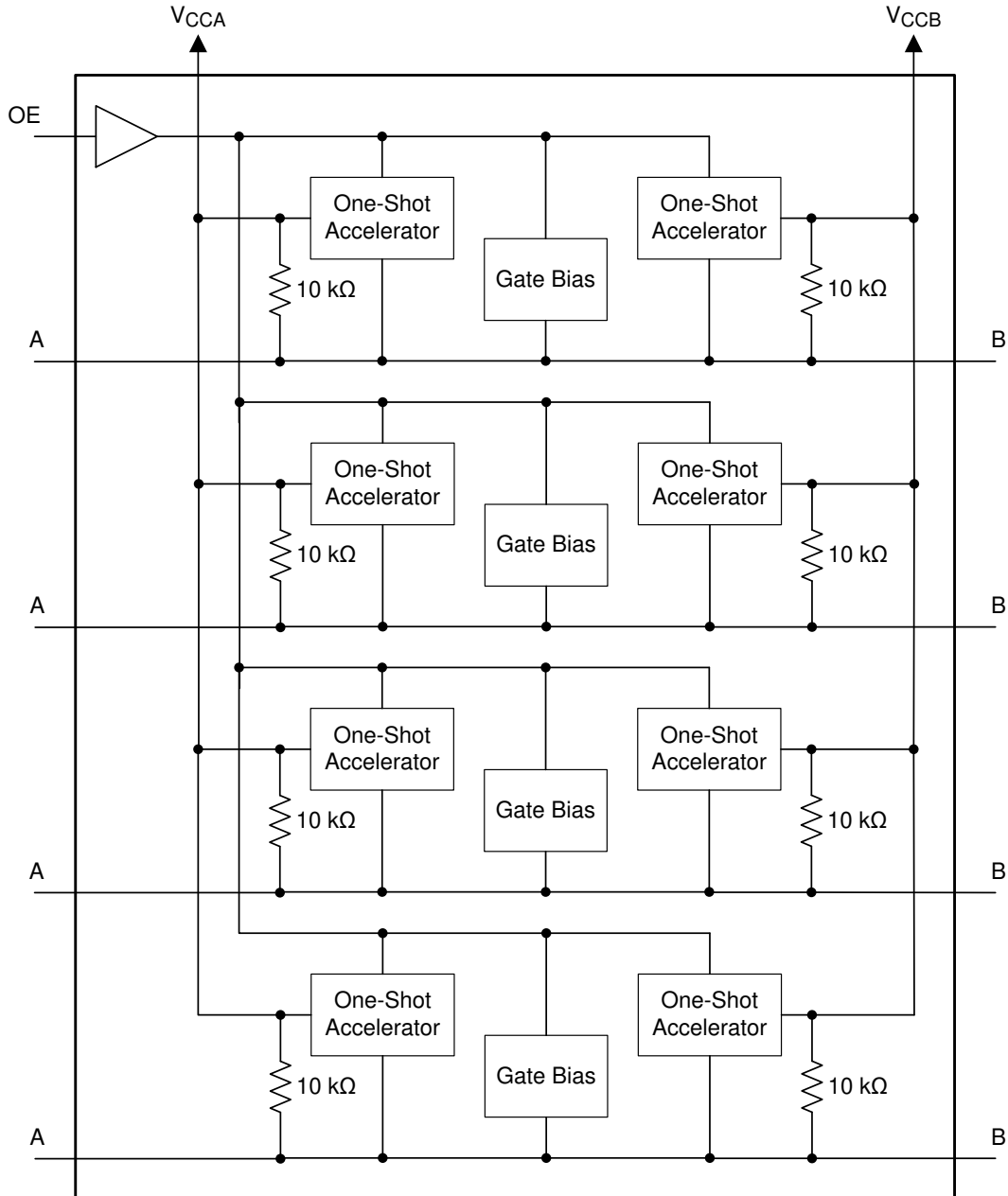

Copyright © 2016, Texas Instruments Incorporated

7.3 Feature Description

7.3.1 Architecture

The TXS0104E-Q1 architecture (see [Figure 7-1](#)) does not require a direction-control signal in order to control the direction of data flow from A to B or from B to A.

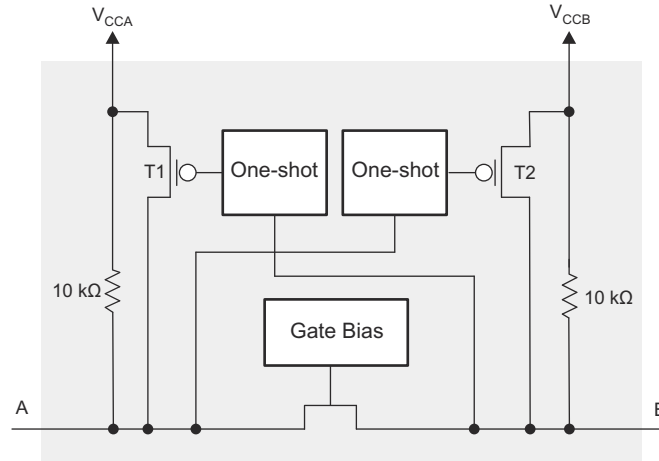

Figure 7-1. Architecture of a TXS01xx Cell

Each A-port I/O has an internal 10-k Ω pullup resistor to V_{CCA} , and each B-port I/O has an internal 10-k Ω pullup resistor to V_{CCB} . The output one-shots detect rising edges on the A or B ports. During a rising edge, the one-shot turns on the PMOS transistors (T1, T2) for a short duration which speeds up the low-to-high transition.

7.3.2 Input Driver Requirements

The fall time (t_{fA} , t_{fB}) of a signal depends on the output impedance of the external device driving the data I/Os of the TXS0104E-Q1 device. Similarly, the t_{PHL} and maximum data rates also depend on the output impedance of the external driver. The values for t_{fA} , t_{fB} , t_{PHL} , and maximum data rates in the data sheet assume that the output impedance of the external driver is less than 50 Ω .

7.3.3 Power Up

During operation, ensure that $V_{CCA} \leq V_{CCB}$ at all times. During power-up sequencing, $V_{CCA} \geq V_{CCB}$ does not damage the device, so any power supply can be ramped up first.

7.3.4 Enable and Disable

The TXS0104E-Q1 device has an OE input that disables the device by setting OE low, which places all I/Os in the high-impedance state. The disable time (t_{dis}) indicates the delay between the time when the OE pin goes low and when the outputs actually enter the high-impedance state. The enable time (t_{en}) indicates the amount of time the user must allow for the one-shot circuitry to become operational after the OE pin is taken high.

7.3.5 Pull Up and Pull Down Resistors on I/O Lines

Each A-port I/O has an internal 10-k Ω pullup resistor to V_{CCA} , and each B-port I/O has an internal 10-k Ω pullup resistor to V_{CCB} . If a smaller value of pullup resistor is required, an external resistor must be added from the I/O to V_{CCA} or V_{CCB} (in parallel with the internal 10-k Ω resistors).

7.4 Device Functional Modes

The TXS0104E-Q1 device has two functional modes, enabled and disabled. To disable the device set the OE input low, which places all I/Os in a high impedance state. Setting the OE input high will enable the device.

8 Application and Implementation

Note

Information in the following applications sections is not part of the TI component specification, and TI does not warrant its accuracy or completeness. TI's customers are responsible for determining suitability of components for their purposes, as well as validating and testing their design implementation to confirm system functionality.

8.1 Application Information

The TXS0104E-Q1 device can be used in level-translation applications for interfacing devices or systems operating at different interface voltages with one another. The TXS0104E-Q1 device is optimal for use in applications where an open-drain driver is connected to the data I/Os. The TXS0104E-Q1 device can also be used in applications where a push-pull driver is connected to the data I/Os, but the TXB0104-Q1 device might be a better option for such push-pull applications.

8.2 Typical Application

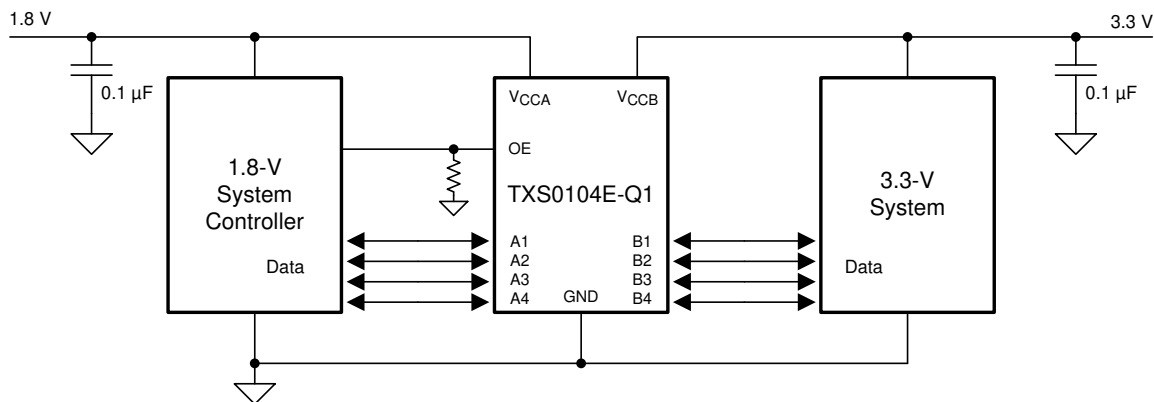

Copyright © 2016, Texas Instruments Incorporated

Figure 8-1. Application Schematic

8.2.1 Design Requirements

For this design example, use the parameters listed in [Table 8-1](#).

Table 8-1. Design Parameters

DESIGN PARAMETER	EXAMPLE VALUE
Input voltage range	1.65 to 3.6 V
Output voltage range	2.3 to 5.5 V

8.2.2 Detailed Design Procedure

To begin the design process, determine the following:

- Input voltage range
 - Use the supply voltage of the device that is driving the TXS0104E-Q1 device to determine the input voltage range. For a valid logic high the value must exceed the V_{IH} of the input port. For a valid logic low the value must be less than the V_{IL} of the input port.
- Output voltage range
 - Use the supply voltage of the device that the TXS0104E-Q1 device is driving to determine the output voltage range.
 - The TXS0104E-Q1 device has 10-k Ω internal pullup resistors. External pullup resistors can be added to reduce the total RC of a signal trace if necessary.

- An external pull down resistor decreases the output V_{OH} and V_{OL} . Use [Equation 1](#) to calculate the V_{OH} as a result of an external pull down resistor.

$$V_{OH} = V_{CCx} \times R_{PD} / (R_{PD} + 10\text{ k}\Omega) \quad (1)$$

where

- V_{CCx} is the supply voltage on either V_{CCA} or V_{CCB}
- R_{PD} is the value of the external pull down resistor

8.2.3 Application Curve

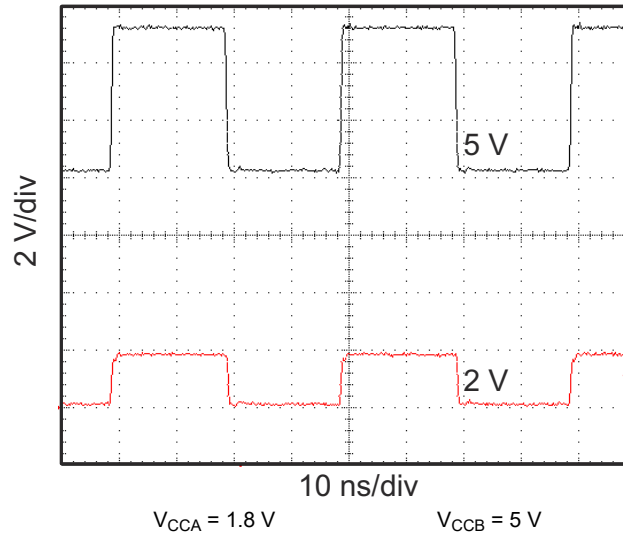

Figure 8-2. Level-Translation of a 2.5-MHz Signal

8.3 Power Supply Recommendations

The TXS0104E-Q1 device uses two separate configurable power-supply rails, V_{CCA} and V_{CCB} . V_{CCB} accepts any supply voltage from 2.3 V to 5.5 V and V_{CCA} accepts any supply voltage from 1.65 V to 3.6 V as long as V_S is less than or equal to V_{CCB} . The A port and B port are designed to track V_{CCA} and V_{CCB} respectively allowing for low-voltage bidirectional translation between any of the 1.8-V, 2.5-V, 3.3-V, and 5-V voltage nodes.

The TXS0104E-Q1 device does not require power sequencing between V_{CCA} and V_{CCB} during power-up so the power-supply rails can be ramped in any order. A V_{CCA} value greater than or equal to V_{CCB} ($V_{CCA} \geq V_{CCB}$) does not damage the device, but during operation, V_{CCA} must be less than or equal to V_{CCB} ($V_{CCA} \leq V_{CCB}$) at all times.

The output-enable (OE) input circuit is designed so that it is supplied by V_{CCA} and when the (OE) input is low, all outputs are placed in the high-impedance state. To enable the high-impedance state of the outputs during power up or power down, the OE input pin must be tied to GND through a pull down resistor and must not be enabled until V_{CCA} and V_{CCB} are fully ramped and stable. The minimum value of the pull down resistor to ground is determined by the current-sourcing capability of the driver.

8.4 Layout

8.4.1 Layout Guidelines

For reliability of the device, following common printed-circuit board layout guidelines is recommended.

- Bypass capacitors should be used on power supplies.
- Short trace lengths should be used to avoid excessive loading.
- PCB signal trace-lengths must be kept short enough so that the round-trip delay of any reflection is less than the one shot duration, approximately 30 ns, ensuring that any reflection encounters low impedance at the source driver.
- Placing pads on the signal paths for loading capacitors or pullup resistors to help adjust rise and fall times of signals depending on the system requirements

8.4.2 Layout Example

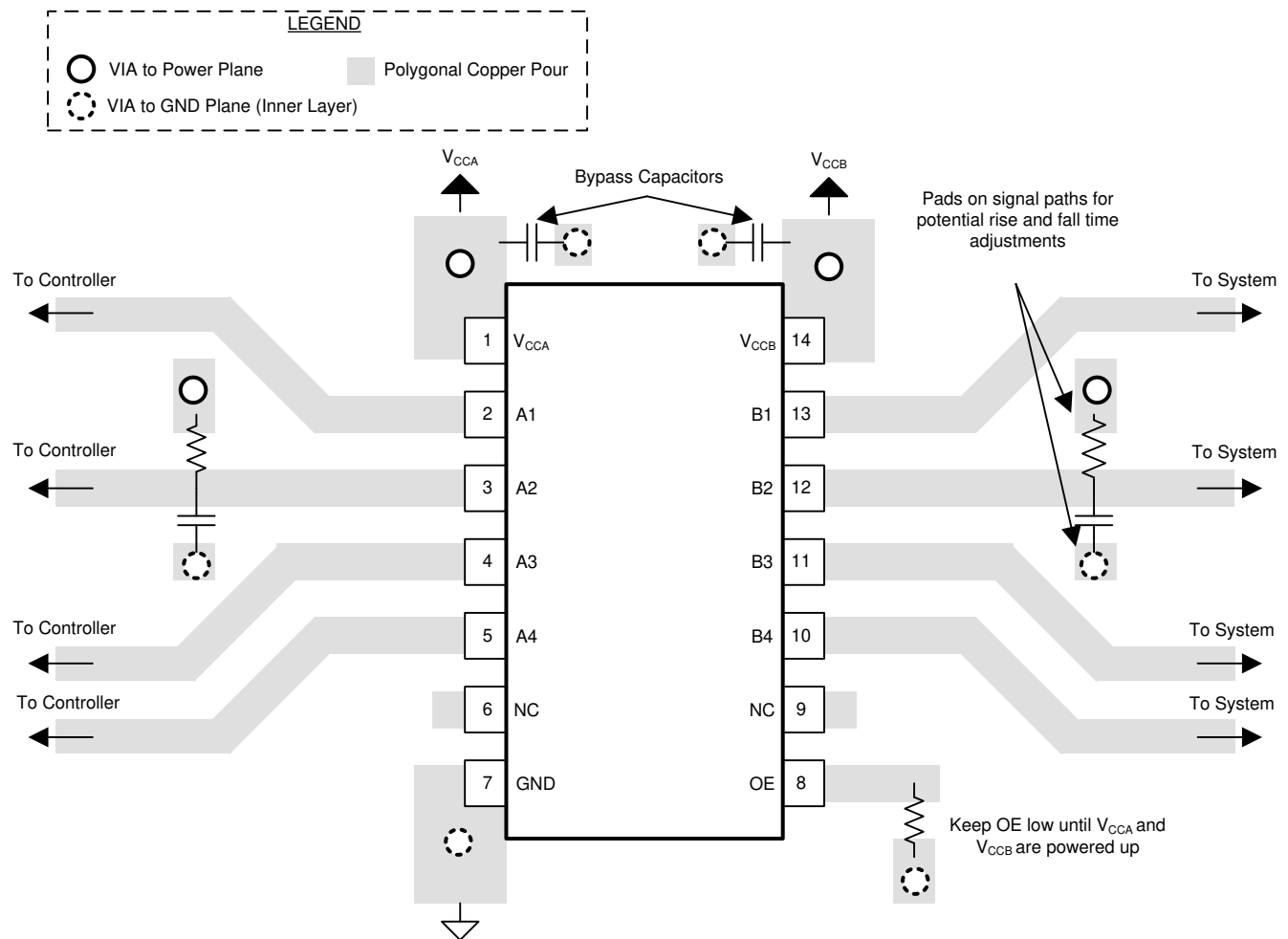

9 Device and Documentation Support

9.1 Documentation Support

9.1.1 Related Documentation

For related documentation, see the following:

- Texas Instruments, [Introduction to Logic application note](#)

9.2 Receiving Notification of Documentation Updates

To receive notification of documentation updates, navigate to the device product folder on ti.com. Click on *Notifications* to register and receive a weekly digest of any product information that has changed. For change details, review the revision history included in any revised document.

9.3 Support Resources

[TI E2E™ support forums](#) are an engineer's go-to source for fast, verified answers and design help — straight from the experts. Search existing answers or ask your own question to get the quick design help you need.

Linked content is provided "AS IS" by the respective contributors. They do not constitute TI specifications and do not necessarily reflect TI's views; see TI's [Terms of Use](#).

9.4 Trademarks

TI E2E™ is a trademark of Texas Instruments.
All trademarks are the property of their respective owners.

10 Electrostatic Discharge Caution



This integrated circuit can be damaged by ESD. Texas Instruments recommends that all integrated circuits be handled with appropriate precautions. Failure to observe proper handling and installation procedures can cause damage.

ESD damage can range from subtle performance degradation to complete device failure. Precision integrated circuits may be more susceptible to damage because very small parametric changes could cause the device not to meet its published specifications.

11 Glossary

[TI Glossary](#) This glossary lists and explains terms, acronyms, and definitions.

12 Revision History

NOTE: Page numbers for previous revisions may differ from page numbers in the current version.

Changes from Revision E (October 2023) to Revision F (October 2024)	Page
• Updated thermal values for new packages.....	6
<hr/>	
Changes from Revision D (January 2017) to Revision E (October 2023)	Page
• Added the <i>RUT</i> package information to the data sheet.....	1
<hr/>	
Changes from Revision C (January 2017) to Revision D (June 2023)	Page
• Updated the numbering format for tables, figures, and cross-references throughout the document.....	1
• Added the <i>BQA</i> package information to the data sheet.....	1

Changes from Revision B (May 2014) to Revision C (January 2017)	Page
• Changed the type of the OE pin from output (O) to input (I) in the <i>Pin Functions</i> table.....	3
• Moved T _{stg} back to the <i>Absolute Maximum Ratings</i> table and changed the <i>Handling Ratings</i> table to <i>ESD Ratings</i>	5

Changes from Revision A (April 2014) to Revision B (May 2014)	Page
• Changed device status from <i>Product Preview</i> to <i>Production Data</i>	1

13 Mechanical, Packaging, and Orderable Information

The following pages include mechanical, packaging, and orderable information. This information is the most current data available for the designated devices. This data is subject to change without notice and revision of this document. For browser-based versions of this data sheet, refer to the left-hand navigation.

PACKAGING INFORMATION

Orderable part number	Status (1)	Material type (2)	Package Pins	Package qty Carrier	RoHS (3)	Lead finish/ Ball material (4)	MSL rating/ Peak reflow (5)	Op temp (°C)	Part marking (6)
TXS0104EQPWRQ1	Active	Production	TSSOP (PW) 14	2000 LARGE T&R	Yes	NIPDAU	Level-2-260C-1 YEAR	-40 to 125	04EQ1
TXS0104EQPWRQ1.A	Active	Production	TSSOP (PW) 14	2000 LARGE T&R	Yes	NIPDAU	Level-2-260C-1 YEAR	-40 to 125	04EQ1
TXS0104EQPWRQ1.B	Active	Production	TSSOP (PW) 14	2000 LARGE T&R	Yes	NIPDAU	Level-2-260C-1 YEAR	-40 to 125	04EQ1
TXS0104EQRUTRQ1	Active	Production	UQFN (RUT) 12	3000 LARGE T&R	Yes	NIPDAU	Level-1-260C-UNLIM	-40 to 125	1RQ
TXS0104EQRUTRQ1.A	Active	Production	UQFN (RUT) 12	3000 LARGE T&R	Yes	NIPDAU	Level-1-260C-UNLIM	-40 to 125	1RQ
TXS0104EQWBQARQ1	Active	Production	WQFN (BQA) 14	3000 LARGE T&R	Yes	NIPDAU	Level-1-260C-UNLIM	-40 to 125	YF04EQ
TXS0104EQWBQARQ1.A	Active	Production	WQFN (BQA) 14	3000 LARGE T&R	Yes	NIPDAU	Level-1-260C-UNLIM	-40 to 125	YF04EQ

(1) **Status:** For more details on status, see our [product life cycle](#).

(2) **Material type:** When designated, preproduction parts are prototypes/experimental devices, and are not yet approved or released for full production. Testing and final process, including without limitation quality assurance, reliability performance testing, and/or process qualification, may not yet be complete, and this item is subject to further changes or possible discontinuation. If available for ordering, purchases will be subject to an additional waiver at checkout, and are intended for early internal evaluation purposes only. These items are sold without warranties of any kind.

(3) **RoHS values:** Yes, No, RoHS Exempt. See the [TI RoHS Statement](#) for additional information and value definition.

(4) **Lead finish/Ball material:** Parts may have multiple material finish options. Finish options are separated by a vertical ruled line. Lead finish/Ball material values may wrap to two lines if the finish value exceeds the maximum column width.

(5) **MSL rating/Peak reflow:** The moisture sensitivity level ratings and peak solder (reflow) temperatures. In the event that a part has multiple moisture sensitivity ratings, only the lowest level per JEDEC standards is shown. Refer to the shipping label for the actual reflow temperature that will be used to mount the part to the printed circuit board.

(6) **Part marking:** There may be an additional marking, which relates to the logo, the lot trace code information, or the environmental category of the part.

Multiple part markings will be inside parentheses. Only one part marking contained in parentheses and separated by a "-" will appear on a part. If a line is indented then it is a continuation of the previous line and the two combined represent the entire part marking for that device.

Important Information and Disclaimer: The information provided on this page represents TI's knowledge and belief as of the date that it is provided. TI bases its knowledge and belief on information provided by third parties, and makes no representation or warranty as to the accuracy of such information. Efforts are underway to better integrate information from third parties. TI has taken and continues to take reasonable steps to provide representative and accurate information but may not have conducted destructive testing or chemical analysis on incoming materials and chemicals. TI and TI suppliers consider certain information to be proprietary, and thus CAS numbers and other limited information may not be available for release.

In no event shall TI's liability arising out of such information exceed the total purchase price of the TI part(s) at issue in this document sold by TI to Customer on an annual basis.

OTHER QUALIFIED VERSIONS OF TXS0104E-Q1 :

- Catalog : [TXS0104E](#)

NOTE: Qualified Version Definitions:

- Catalog - TI's standard catalog product

TAPE AND REEL INFORMATION

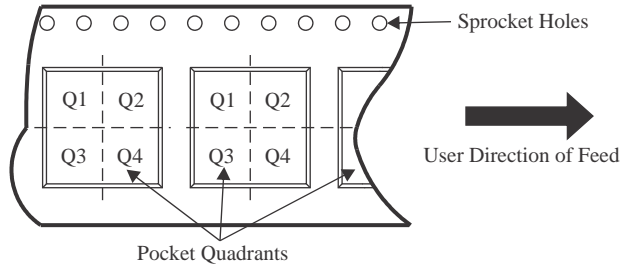
QUADRANT ASSIGNMENTS FOR PIN 1 ORIENTATION IN TAPE

*All dimensions are nominal

Device	Package Type	Package Drawing	Pins	SPQ	Reel Diameter (mm)	Reel Width W1 (mm)	A0 (mm)	B0 (mm)	K0 (mm)	P1 (mm)	W (mm)	Pin1 Quadrant
TXS0104EQPWRQ1	TSSOP	PW	14	2000	330.0	12.4	6.9	5.6	1.6	8.0	12.0	Q1
TXS0104EQRUTRQ1	UQFN	RUT	12	3000	180.0	8.4	2.0	2.3	0.75	4.0	8.0	Q1
TXS0104EQWBQARQ1	WQFN	BQA	14	3000	180.0	12.4	2.8	3.3	1.1	4.0	12.0	Q1

TAPE AND REEL BOX DIMENSIONS



*All dimensions are nominal

Device	Package Type	Package Drawing	Pins	SPQ	Length (mm)	Width (mm)	Height (mm)
TXS0104EQPWRQ1	TSSOP	PW	14	2000	353.0	353.0	32.0
TXS0104EQRUTRQ1	UQFN	RUT	12	3000	210.0	185.0	35.0
TXS0104EQWBQARQ1	WQFN	BQA	14	3000	210.0	185.0	35.0

GENERIC PACKAGE VIEW

BQA 14

WQFN - 0.8 mm max height

2.5 x 3, 0.5 mm pitch

PLASTIC QUAD FLATPACK - NO LEAD

This image is a representation of the package family, actual package may vary.
Refer to the product data sheet for package details.

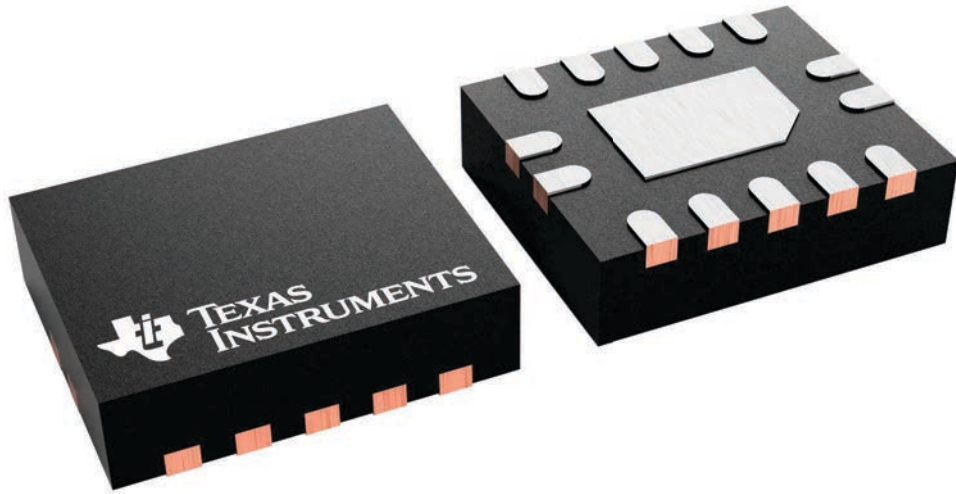

4227145/A

BQA0014B

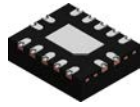

PACKAGE OUTLINE

WQFN - 0.8 mm max height

PLASTIC QUAD FLATPACK - NO LEAD

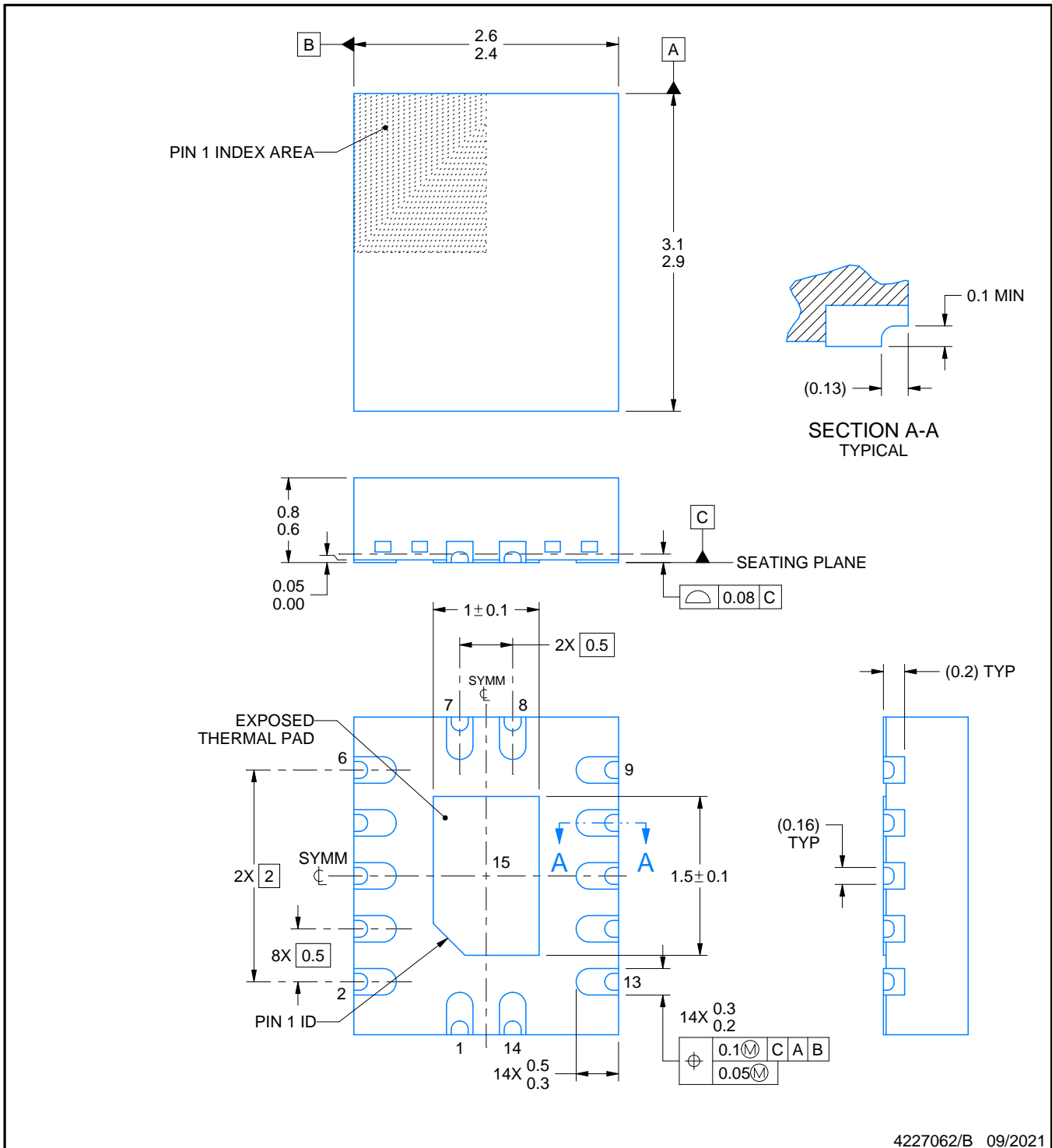

4227062/B 09/2021

NOTES:

1. All linear dimensions are in millimeters. Any dimensions in parenthesis are for reference only. Dimensioning and tolerancing per ASME Y14.5M.
2. This drawing is subject to change without notice.
3. The package thermal pad must be soldered to the printed circuit board for thermal and mechanical performance.

EXAMPLE BOARD LAYOUT

BQA0014B

WQFN - 0.8 mm max height

PLASTIC QUAD FLATPACK - NO LEAD

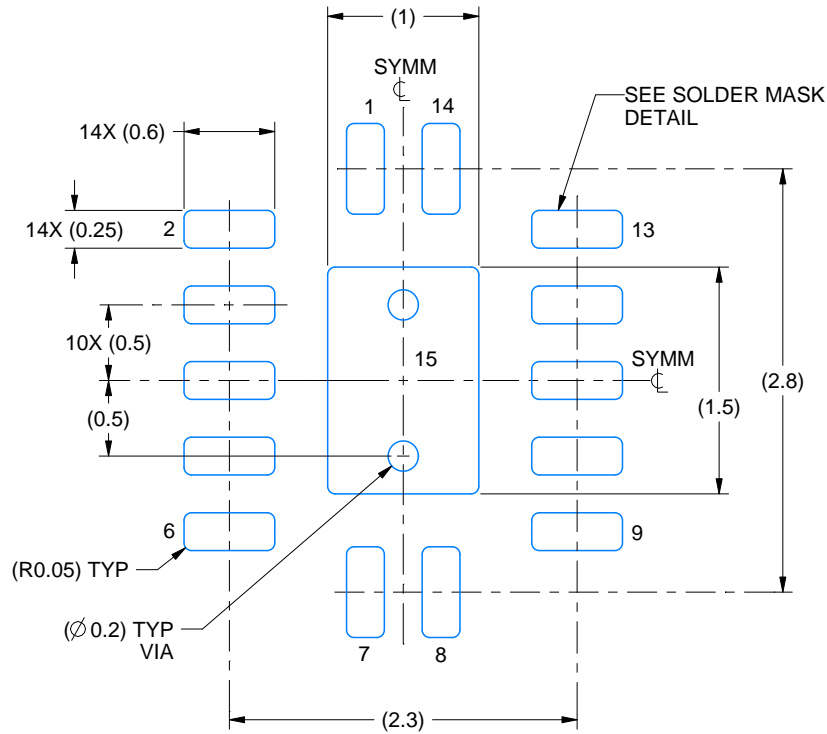

LAND PATTERN EXAMPLE
EXPOSED METAL SHOWN
SCALE: 20X

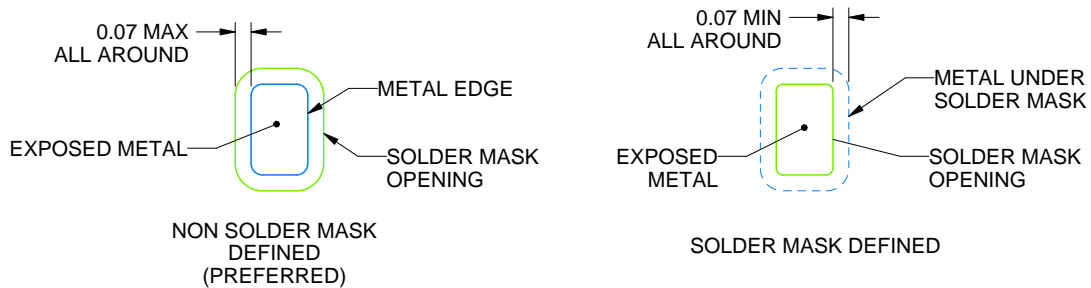

SOLDER MASK DETAILS

4227062/B 09/2021

NOTES: (continued)

4. This package is designed to be soldered to a thermal pad on the board. For more information, see Texas Instruments literature number SLUA271 (www.ti.com/lit/sluea271).
5. Vias are optional depending on application, refer to device data sheet. If any vias are implemented, refer to their locations shown on this view. It is recommended that vias under paste be filled, plugged or tented.

EXAMPLE STENCIL DESIGN

BQA0014B

WQFN - 0.8 mm max height

PLASTIC QUAD FLATPACK - NO LEAD

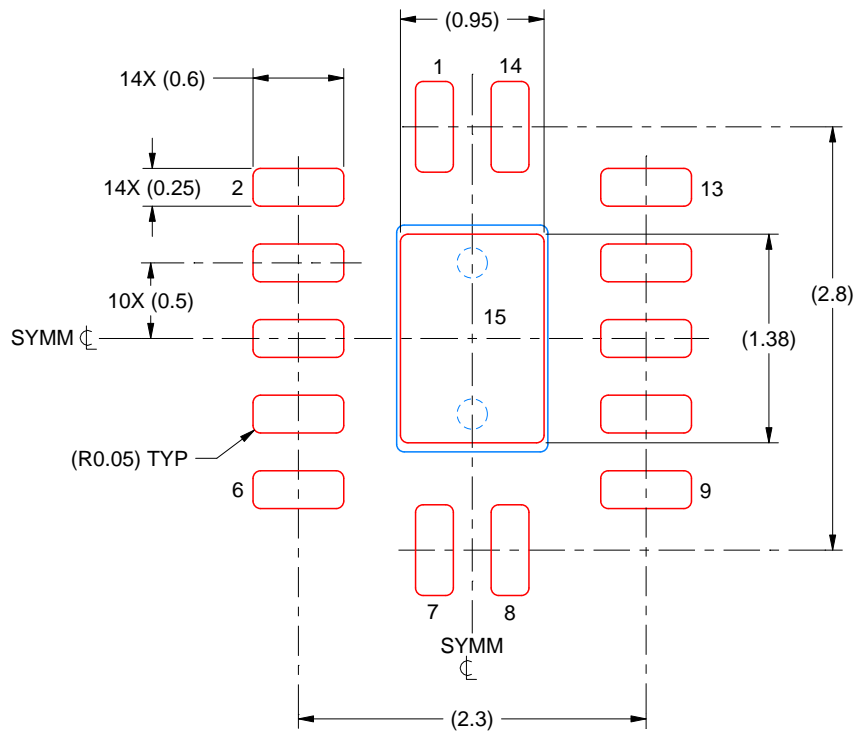

SOLDER PASTE EXAMPLE
BASED ON 0.125 MM THICK STENCIL
SCALE: 20X

EXPOSED PAD 15
87% PRINTED SOLDER COVERAGE BY AREA UNDER PACKAGE

4227062/B 09/2021

NOTES: (continued)

6. Laser cutting apertures with trapezoidal walls and rounded corners may offer better paste release. IPC-7525 may have alternate design recommendations.

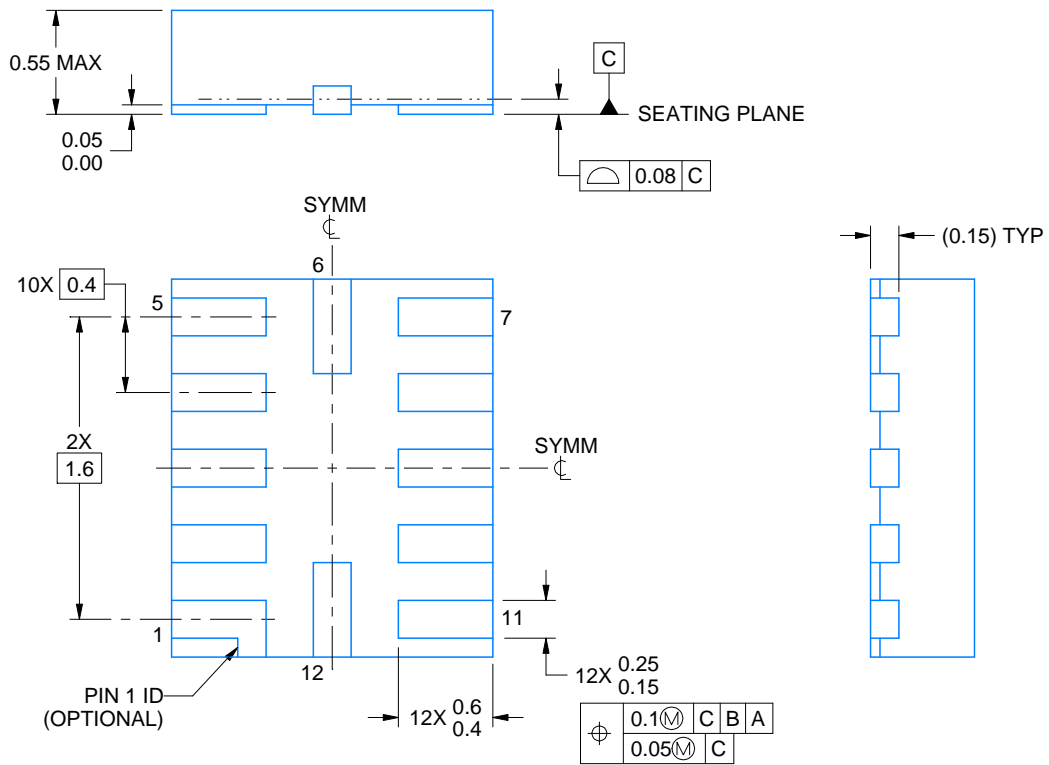
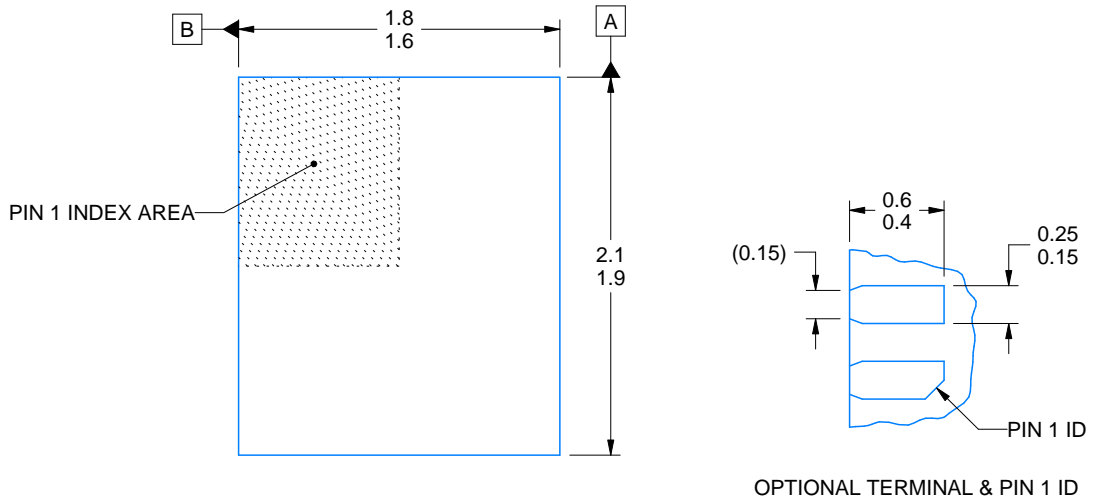
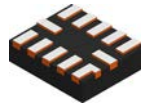

4220310/A 11/2016

NOTES:

1. All linear dimensions are in millimeters. Any dimensions in parenthesis are for reference only. Dimensioning and tolerancing per ASME Y14.5M.
2. This drawing is subject to change without notice.

EXAMPLE BOARD LAYOUT

RUT0012A

UQFN - 0.55 mm max height

PLASTIC QUAD FLATPACK - NO LEAD

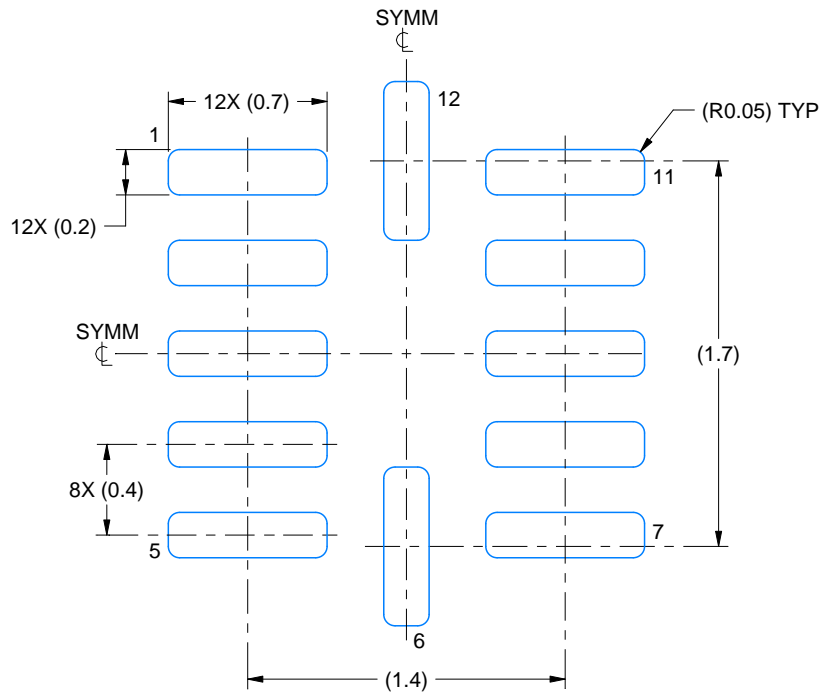

LAND PATTERN EXAMPLE
SCALE:30X

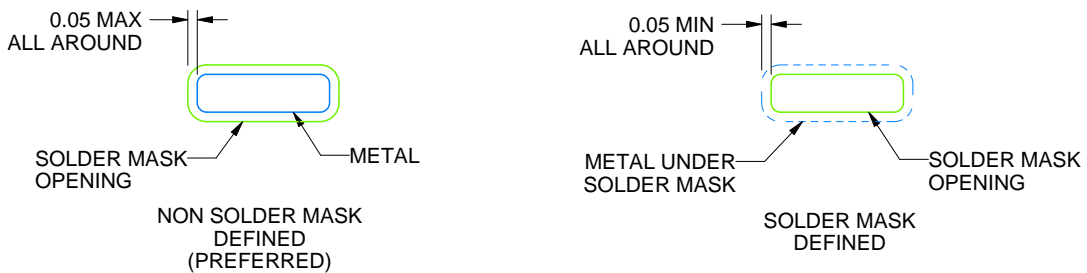

SOLDER MASK DETAILS

4220310/A 11/2016

NOTES: (continued)

3. For more information, see Texas Instruments literature number SLUA271 (www.ti.com/lit/sluea271).

EXAMPLE STENCIL DESIGN

RUT0012A

UQFN - 0.55 mm max height

PLASTIC QUAD FLATPACK - NO LEAD

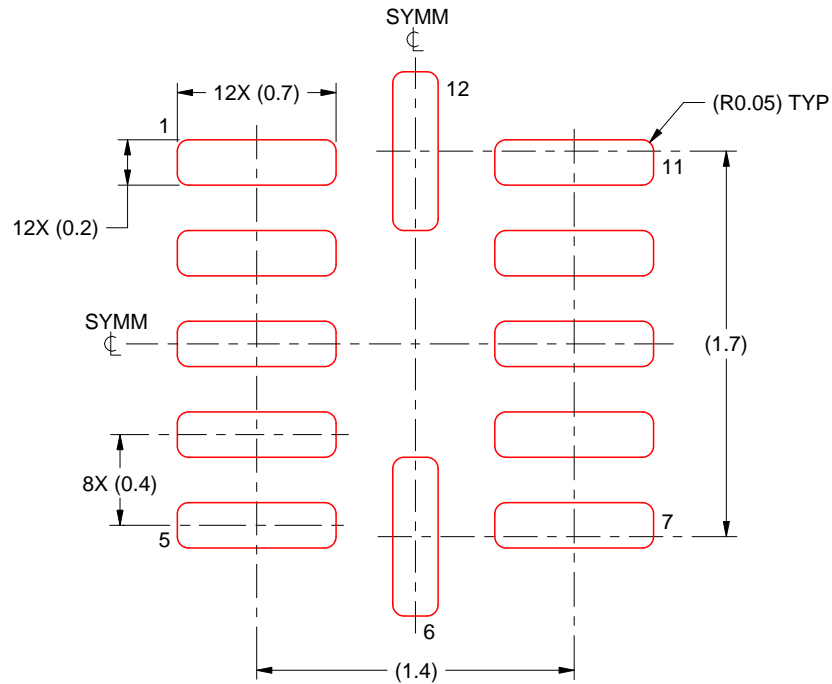

SOLDER PASTE EXAMPLE
BASED ON 0.1 mm THICK STENCIL
SCALE: 30X

4220310/A 11/2016

NOTES: (continued)

4. Laser cutting apertures with trapezoidal walls and rounded corners may offer better paste release. IPC-7525 may have alternate design recommendations.

PW0014A



PACKAGE OUTLINE
TSSOP - 1.2 mm max height

SMALL OUTLINE PACKAGE



4220202/B 12/2023

NOTES:

1. All linear dimensions are in millimeters. Any dimensions in parenthesis are for reference only. Dimensioning and tolerancing per ASME Y14.5M.
2. This drawing is subject to change without notice.
3. This dimension does not include mold flash, protrusions, or gate burrs. Mold flash, protrusions, or gate burrs shall not exceed 0.15 mm per side.
4. This dimension does not include interlead flash. Interlead flash shall not exceed 0.25 mm per side.
5. Reference JEDEC registration MO-153.

EXAMPLE BOARD LAYOUT

PW0014A

TSSOP - 1.2 mm max height

SMALL OUTLINE PACKAGE



LAND PATTERN EXAMPLE
EXPOSED METAL SHOWN
SCALE: 10X



4220202/B 12/2023

NOTES: (continued)

- 6. Publication IPC-7351 may have alternate designs.
- 7. Solder mask tolerances between and around signal pads can vary based on board fabrication site.

EXAMPLE STENCIL DESIGN

PW0014A

TSSOP - 1.2 mm max height

SMALL OUTLINE PACKAGE



SOLDER PASTE EXAMPLE
BASED ON 0.125 mm THICK STENCIL
SCALE: 10X

4220202/B 12/2023

NOTES: (continued)

8. Laser cutting apertures with trapezoidal walls and rounded corners may offer better paste release. IPC-7525 may have alternate design recommendations.
9. Board assembly site may have different recommendations for stencil design.

IMPORTANT NOTICE AND DISCLAIMER

TI PROVIDES TECHNICAL AND RELIABILITY DATA (INCLUDING DATASHEETS), DESIGN RESOURCES (INCLUDING REFERENCE DESIGNS), APPLICATION OR OTHER DESIGN ADVICE, WEB TOOLS, SAFETY INFORMATION, AND OTHER RESOURCES "AS IS" AND WITH ALL FAULTS, AND DISCLAIMS ALL WARRANTIES, EXPRESS AND IMPLIED, INCLUDING WITHOUT LIMITATION ANY IMPLIED WARRANTIES OF MERCHANTABILITY, FITNESS FOR A PARTICULAR PURPOSE OR NON-INFRINGEMENT OF THIRD PARTY INTELLECTUAL PROPERTY RIGHTS.

These resources are intended for skilled developers designing with TI products. You are solely responsible for (1) selecting the appropriate TI products for your application, (2) designing, validating and testing your application, and (3) ensuring your application meets applicable standards, and any other safety, security, regulatory or other requirements.

These resources are subject to change without notice. TI grants you permission to use these resources only for development of an application that uses the TI products described in the resource. Other reproduction and display of these resources is prohibited. No license is granted to any other TI intellectual property right or to any third party intellectual property right. TI disclaims responsibility for, and you fully indemnify TI and its representatives against any claims, damages, costs, losses, and liabilities arising out of your use of these resources.

TI's products are provided subject to [TI's Terms of Sale](#), [TI's General Quality Guidelines](#), or other applicable terms available either on [ti.com](#) or provided in conjunction with such TI products. TI's provision of these resources does not expand or otherwise alter TI's applicable warranties or warranty disclaimers for TI products. Unless TI explicitly designates a product as custom or customer-specified, TI products are standard, catalog, general purpose devices.

TI objects to and rejects any additional or different terms you may propose.

Copyright © 2025, Texas Instruments Incorporated

Last updated 10/2025

Looking for pricing, stock, or lifecycle information?

Click below to explore more details on WIN SOURCE:

 [View TXS0104EQRUTRQ1 on WIN SOURCE](#)

 [Texas Instruments](#) Information

Optimize Your Supply Chain with WIN SOURCE Solutions

-  Global Sourcing Solution
-  Obsolete Management
-  Cost Control Management
-  Shortage Management
-  Alternative Solution
-  Excess Inventory Management