

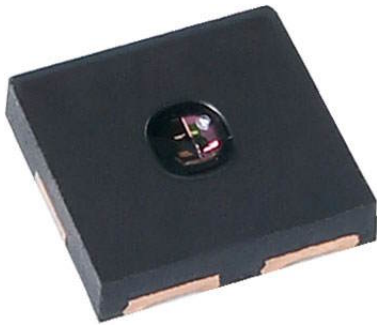

**THE DATASHEET OF
VEML6031X00**



High Accuracy Ambient Light Sensor With I²C Interface



LINKS TO ADDITIONAL RESOURCES



DESCRIPTION

VEML6031X00 is a high accuracy ambient light digital 16-bit resolution sensor in a miniature opaque 2.67 mm x 2.45 mm package. It includes a high sensitive photodiode, a low noise amplifier, a 16-bit A/D converter and supports an easy to use I²C bus communication interface and additional interrupt feature.

The ambient light result is as digital value available.

APPLICATIONS

Ambient light sensor in automotive for

- Display backlight controls
- Infotainment systems
- Rear view mirror dimming
- Interior lighting control systems
- Head-up displays

FEATURES

- Package type: surface-mount
- Dimensions (L x W x H in mm): 2.67 x 2.45 x 0.6
- AEC-Q100 qualified
- Integrated modules: ambient light sensor (ALS)
- Supply voltage range V_{DD} : 2.5 V to 3.6 V
- Communication via I²C interface
- I²C bus H-level range: 1.7 V to 3.6 V
- Floor life: 4 weeks, MSL 2a, according to J-STD-020
- Low shut down current consumption: typ. 0.5 μ A
- Material categorization: for definitions of compliance please see www.vishay.com/doc?99912

 AUTOMOTIVE
GRADE

RoHS
COMPLIANT
HALOGEN
FREE
GREEN
(5-2008)

AMBIENT LIGHT FUNCTION

- Filtron™ technology adaption: close to real human eye response
- Typical ALS output tolerance of $\leq 10\%$ under different light sources
- 16-bit dynamic range for ambient light detection from 0 lx to about 228 klx with resolution down to 0.0034 lx/ct, supports low transmittance (dark) lens design
- Excellent temperature compensation
- High dynamic detection resolution

PRODUCT SUMMARY

PART NUMBER	OPERATING VOLTAGE RANGE (V)	I ² C BUS VOLTAGE RANGE (V)	AMBIENT LIGHT RANGE (lx)	AMBIENT LIGHT RESOLUTION (lx)	OUTPUT CODE	ADC RESOLUTION PROXIMITY / AMBIENT LIGHT
VEML6031X00	2.5 to 3.6	1.7 to 3.6	0 to 228 000	0.0034	16 bit, I ² C	- / 16 bit

ORDERING INFORMATION

ORDERING CODE	PACKAGING	VOLUME ⁽¹⁾	REMARKS
VEML6031X00	Tape and reel	MOQ: 3000	2.67 mm x 2.45 mm x 0.6 mm
VEML6031X00-GS15	Tape and reel	MOQ: 10 000	2.67 mm x 2.45 mm x 0.6 mm
VEML60311X00	Tape and reel	MOQ: 3000	2.67 mm x 2.45 mm x 0.6 mm
VEML60311X00-GS15	Tape and reel	MOQ: 10 000	2.67 mm x 2.45 mm x 0.6 mm

Note

⁽¹⁾ MOQ: minimum order quantity

SLAVE ADDRESS OPTIONS	
ORDERING CODE	SLAVE ADDRESS (7 bit)
VEML6031X00	0x29
VEML60311X00	0x10

ABSOLUTE MAXIMUM RATINGS ($T_{amb} = 25\text{ }^{\circ}\text{C}$, unless otherwise specified)					
PARAMETER	TEST CONDITION	SYMBOL	MIN.	MAX.	UNIT
Supply voltage		V_{DD}	0	3.6	V
Operation temperature range		T_{amb}	-40	+110	$^{\circ}\text{C}$
Storage temperature range		T_{stg}	-40	+110	$^{\circ}\text{C}$
Total power dissipation	$T_{amb} \leq 25\text{ }^{\circ}\text{C}$	P_{tot}	-	50	mW
Junction temperature		T_j	-	110	$^{\circ}\text{C}$

BASIC CHARACTERISTICS ($T_{amb} = 25\text{ }^{\circ}\text{C}$, unless otherwise specified)						
PARAMETER	TEST CONDITION	SYMBOL	MIN.	TYP.	MAX.	UNIT
Supply voltage		V_{DD}	2.5	3.3	3.6	V
Shut down current ⁽¹⁾	$V_{DD} = V_{BUS}$	I_{sd}	-	0.5	-	μA
	$V_{DD} = V_{BUS} = 3.0\text{ V}$		-	-	1.2	
	V_{DD} is 3.6 V and $V_{BUS} = 1.7\text{ V}$		-	3.1	-	
Active mode current	V_{DD} is 3.3 V	I_{DD}	-	280	-	μA
I ² C clock rate range		f_{SCL}	10	-	400	kHz
I ² C bus input H-level range	$V_{BUS} = V_{DD}$	V_{ih}	$0.7 \times V_{DD}$	-	3.6	V
	$V_{BUS} \neq V_{DD}$	V_{ih}	$0.85 \times V_{BUS}$	-	3.6	V
I ² C bus input L-level range	$V_{BUS} = V_{DD}$	V_{il}	-0.3	-	$0.3 \times V_{DD}$	V
	$V_{BUS} \neq V_{DD}$	V_{il}	-0.3	-	$0.2 \times V_{BUS}$	V
Digital current out (low, current sink)		I_{ol}	3	-	-	mA
Digital resolution (LSB count) ⁽²⁾	With ALS_GAIN = x 2, ALS_IT = 400 ms, PD_DIV4 = 4/4 PD		-	0.0034	-	lx/step
Detectable maximum illuminance	With ALS_GAIN = x 0.5, ALS_IT = 6.25 ms, PD_DIV4 = 1/4 PD	$E_{V\text{ max.}}$	-	228 000	-	lx
ALS dark offset ⁽¹⁾	With ALS_GAIN = x 2, IT = 200 ms, PD_DIV4 = 4/4 PD		-	4	-	step
IR dark offset ⁽¹⁾	With ALS_GAIN = x 2, IT = 200 ms, PD_DIV4 = 4/4 PD		-	4	-	step

Notes

- (1) Light conditions: dark
 (2) Light conditions: $E_v = 100\text{ lx}$ with 4300K white LED

CIRCUIT BLOCK DIAGRAM

Fig. 1 - Block Diagram

I²C TIMING CHARACTERISTICS ($T_{amb} = 25\text{ }^{\circ}\text{C}$, unless otherwise specified)						
PARAMETER	SYMBOL	STANDARD MODE ⁽¹⁾		FAST MODE ⁽¹⁾		UNIT
		MIN.	MAX.	MIN.	MAX.	
Clock frequency	$f_{(SMBCLK)}$	10	100	10	400	kHz
Bus free time between start and stop condition	$t_{(BUF)}$	4.7	-	1.3	-	μs
Hold time after (repeated) start condition; after this period, the first clock is generated	$t_{(HDSTA)}$	4.0	-	0.6	-	μs
Repeated start condition setup time	$t_{(SUSTA)}$	4.7	-	0.6	-	μs
Stop condition setup time	$t_{(SUSTO)}$	4.0	-	0.6	-	μs
Data hold time	$t_{(HDDAT)}$	0	3450	0	900	ns
Data setup time	$t_{(SUDAT)}$	250	-	100	-	ns
I ² C clock (SCK) low period	$t_{(LOW)}$	4.7	-	1.3	-	μs
I ² C clock (SCK) high period	$t_{(HIGH)}$	4.0	-	0.6	-	μs
Detect clock / data low timeout	$t_{(TIMEOUT)}$	25	35	-	-	ms
Clock / data fall time	$t_{(F)}$	-	300	-	300	ns
Clock / data rise time	$t_{(R)}$	-	1000	-	300	ns

Note

(1) Data based on standard I²C protocol requirement, not tested in production

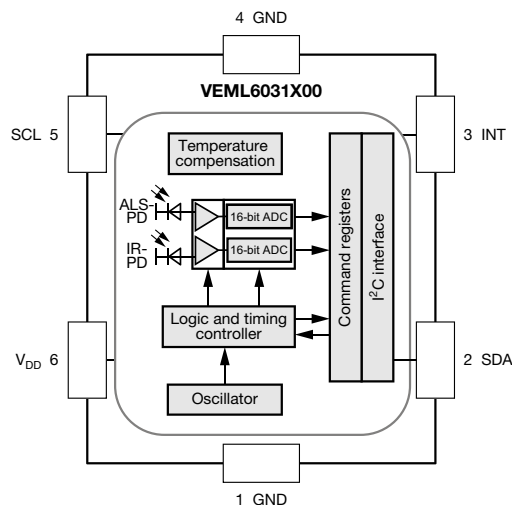
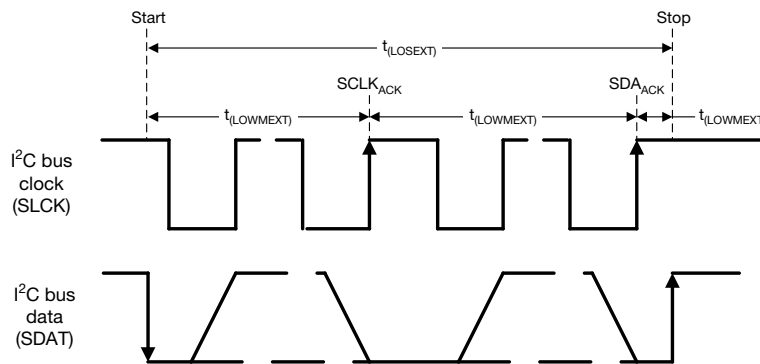
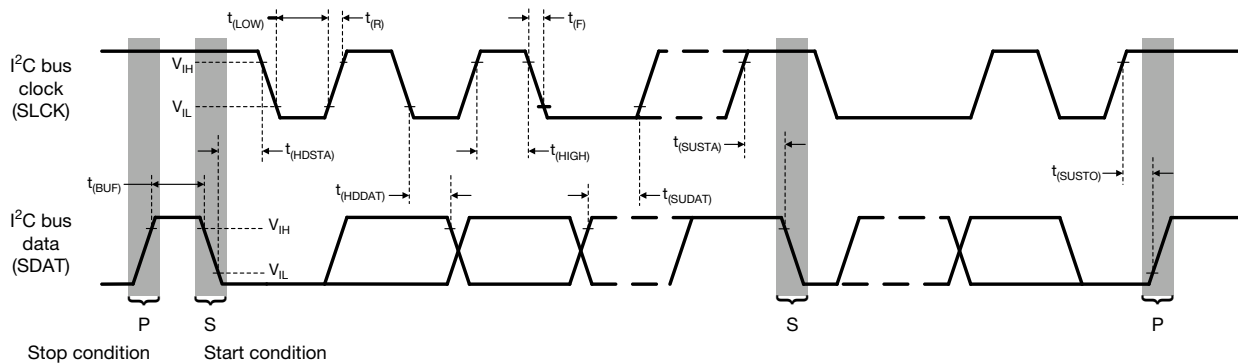

Fig. 2 - I²C Timing Diagram

PARAMETER TIMING INFORMATION

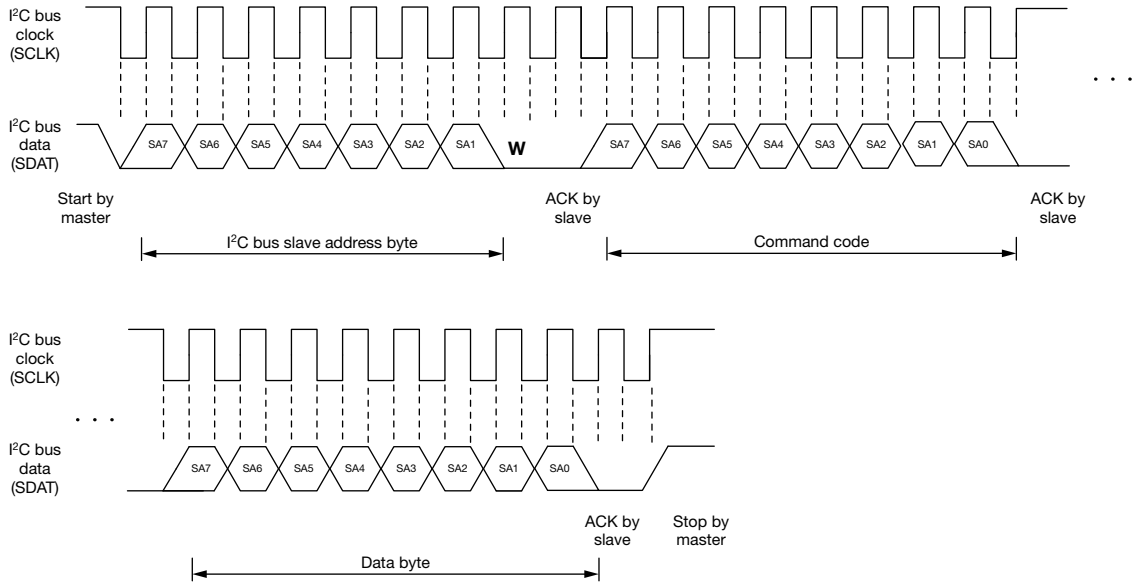

Fig. 3 - I²C Bus Timing for Sending Word Command Format

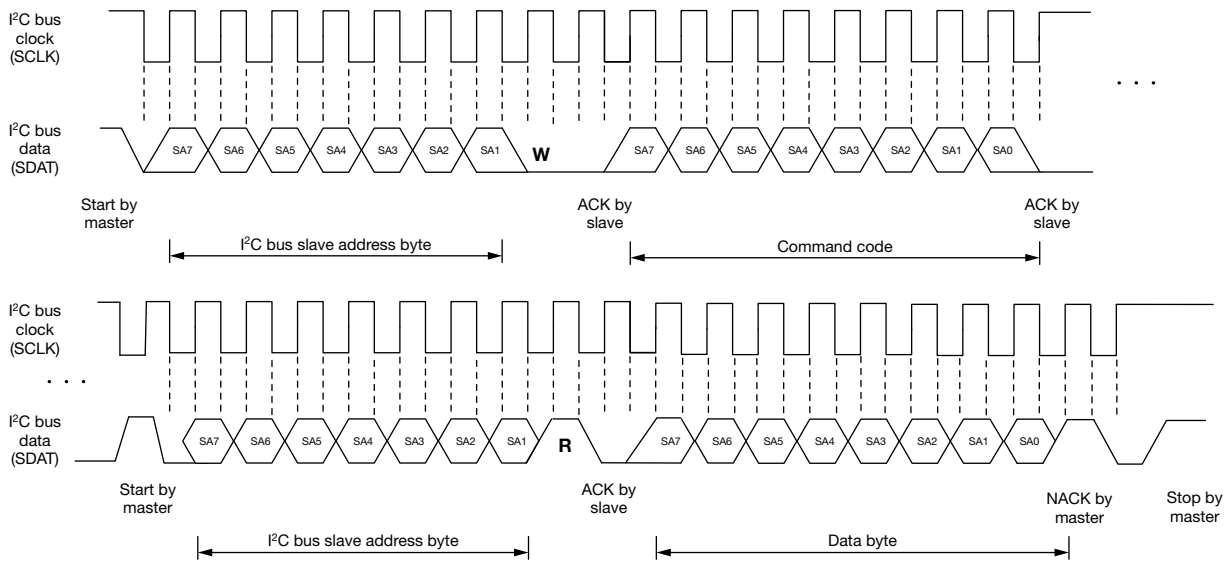

Fig. 4 - I²C Bus Timing for Receive Word Command Format

BASIC CHARACTERISTICS ($T_{amb} = 25\text{ }^{\circ}\text{C}$, unless otherwise specified)

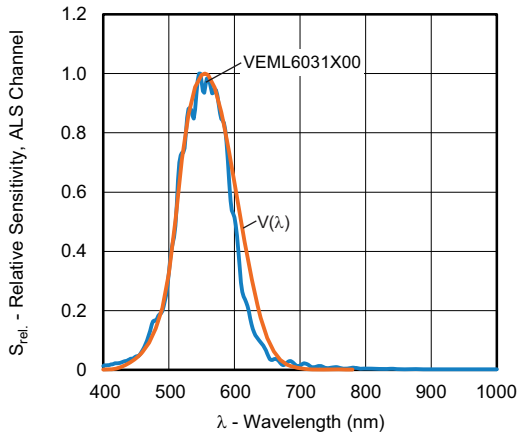

Fig. 5 - Relative Sensitivity, ALS Channel vs. Wavelength

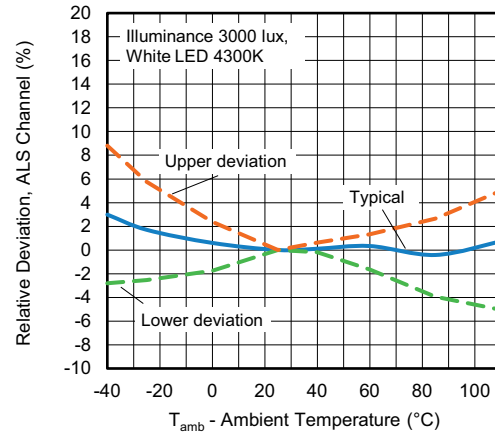

Fig. 8 - Relative Deviation, ALS Channel vs. Temperature (at lux levels lower than ~200 lux, dark current effects should be taken into account, ref. Fig. 9)

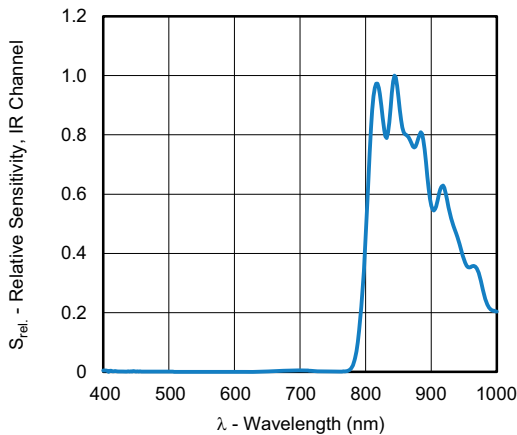

Fig. 6 - Relative Sensitivity, IR Channel vs. Wavelength

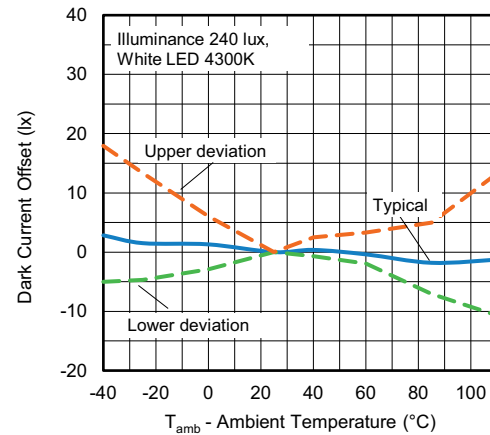

Fig. 9 - Dark Current Offset vs. Ambient Temperature

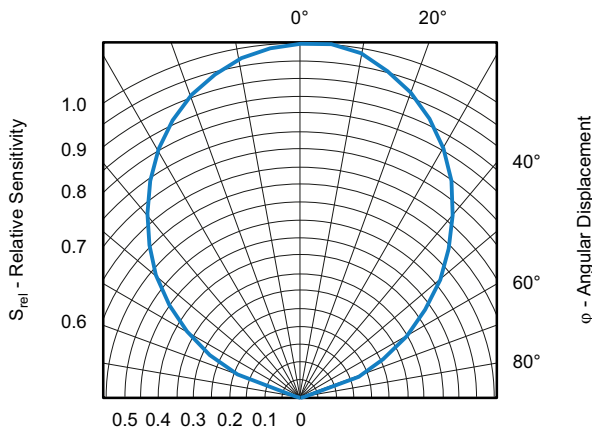

Fig. 7 - Relative Sensitivity vs. Angular Displacement

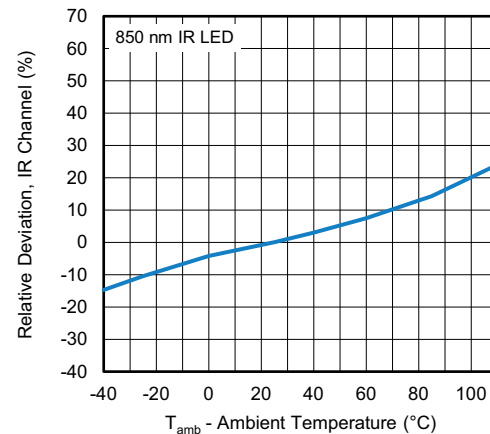

Fig. 10 - Relative Deviation IR Channel vs. Ambient Temperature

APPLICATION INFORMATION

Special care must be taken into consideration when handling the VEML6031X00. VEML6031X00 is sensitive to dust and scratches, proper optical device handling procedures are recommended.

The optical surface of the device must be kept clean for optimal performance in both prototyping with the device and mass production manufacturing procedures. Tweezers with plastic or rubber contact surfaces are recommended to avoid scratches on the optical surface. Avoid manipulation with metal tools when possible. The optical surface must be kept clean of fingerprints, dust, and other optical-inhibiting contaminants.

If the device optical surface requires cleaning, the use of isopropyl alcohol is recommended. A few gentle brushes with a soft swab are appropriate. Avoid potentially abrasive cleaning and manipulating tools and excessive force that can scratch the optical surface.

If the VEML6031X00 performs less than optimally, inspect the optical surface for dirt, scratches, or other optical artifacts.

VEML6031X00 is a cost effective solution of ambient light sensor with I²C bus interface. The standard serial digital interface is easy to access “Ambient Light Signal” without complex calculation and programming by external controller. Beside the digital output also a flexible programmable interrupt pin is available.

1. Application Circuit

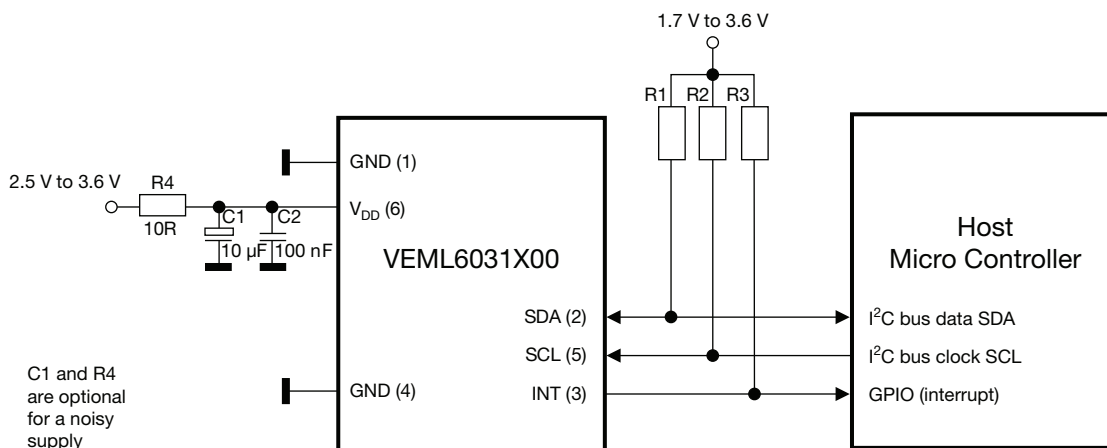

Fig. 11 - Application Circuit
(x) = Pin Number

Notes

- The interrupt pin is an open drain output. Proposed values for the pull-up resistors should be > 1 k Ω , e.g. 2.2 k Ω to 4.7 k Ω for the R1 and R2 (at SDA and SCL) and 10 k Ω to 100 k Ω for R3 (at interrupt).

Normally just one decoupling capacitor is needed. This should be \geq 100 nF and placed close to the V_{DD} pin.

For detailed description about set-up and use of the interrupt as well as more application related information see AN: “Designing VEML6031X00 into an Application”.

2. I²C Interface

The VEML6031X00 has eighteen register addresses responsible for operation control, parameter setup and result buffering. All registers are accessible via I²C communication. Fig. 9 shows the basic I²C communication with VEML6031X00.

The built in I²C interface is compatible with I²C modes “standard” and “fast”: 10 kHz to 400 kHz.

Please refer to the I²C specification from NXP for details.

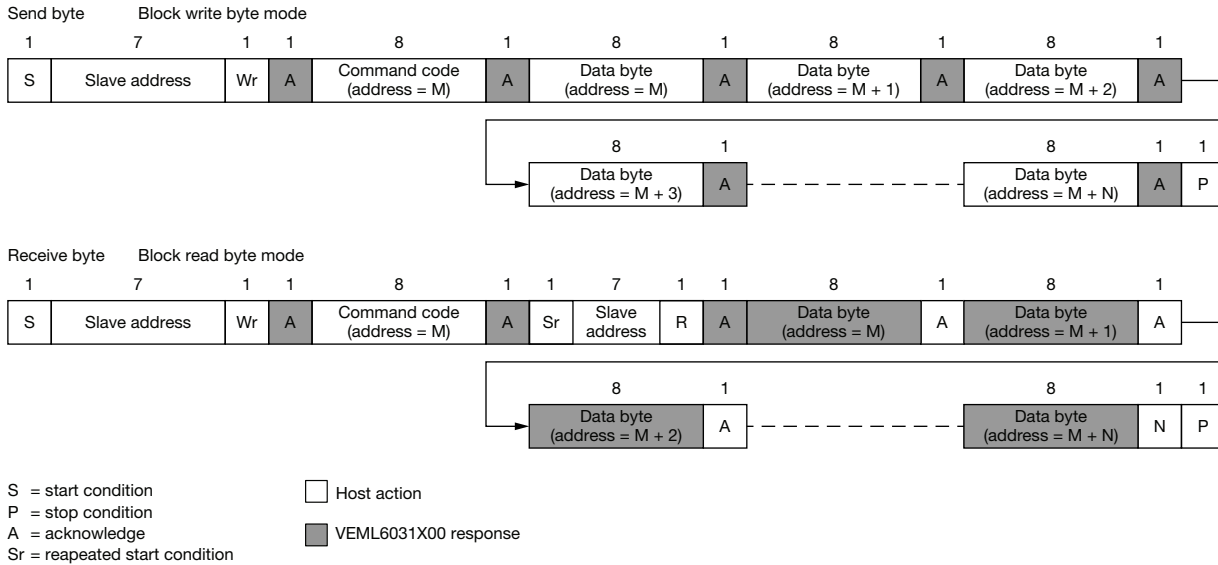

Fig. 12 - Send Byte / Receive Byte Protocol

Device Address

The VEML6031X00 is available in two different pre-configured slave addresses.

For one version the predefined 7 bit I²C bus address is set to 0101001 = 0x29. The least significant bit (LSB) defines read or write mode. Accordingly the bus address is set to 0101 0010 = 0x52 for write and 0101 0011 = 0x53 for read. The second version comes with predefined 7 bit I²C bus address of 0010000 = 0x10, so, here the write address is 0010 0000 = 0x20 for write and 0010 0001 = 0x21 for read.

Register Addresses

The VEML6031X00 has eighteen registers, accessible through their respective 8-bit command codes.

The registers are 0x00 to 0x17 (0x02 and 0x03, 0x08 to 0x0F and 0x16 are not defined / reserved). Note that due to the location of the two shutdown bits (SD and ALS_IR_SD), one in register 0x00 and the other in 0x01, it is necessary to always write to both registers at once when configuring the device.

Auto-Memorization

The VEML6031X00 stores the last measured ambient data before the device is shutdown, keeping the data accessible. When VEML6031X00 is in shutdown mode, the host can freely read this data via read command directly.



COMMAND REGISTER FORMAT					
COMMAND CODE	REGISTER NAME	BIT	DEFAULT VALUE	FUNCTION / DESCRIPTION	R / W
0x00	ALS_CONF 0	0 : 7	0x01	ALS integration time, measurement mode, shutdown	R/W
0x01	ALS_CONF 1	0 : 7	0x00	ALS and IR shutdown, ALS gain, interrupt persistence	R/W
0x04	ALS_WH_L	0 : 7	0x00	ALS high threshold window setting (LSB)	R/W
0x05	ALS_WH_H	0 : 7	0x00	ALS high threshold window setting (MSB)	R/W
0x06	ALS_WL_L	0 : 7	0x00	ALS low threshold window setting (LSB)	R/W
0x07	ALS_WL_H	0 : 7	0x00	ALS low threshold window setting (MSB)	R/W
0x10	ALS_DATA_L	0 : 7	0x00	Low byte of 16-bit ALS result DATA	R
0x11	ALS_DATA_H	0 : 7	0x00	High byte of 16-bit ALS result DATA	R
0x12	IR_DATA_L	0 : 7	0x00	Low byte of 16-bit IR result DATA	R
0x13	IR_DATA_H	0 : 7	0x00	High byte of 16-bit IR result DATA	R
0x14	ID_L	0 : 7	0x01	ID code	R
0x15	ID_H	0 : 7	0x00	Package and version code	R
0x17	ALS_INT	0 : 7	0x00	ALS INT trigger event	R

Notes

- Command code 0x00 default value is 0x01 = device is shutdown
- Command 0x00 and command 0x01 must be executed together, they cannot be executed independently

TABLE 1 - REGISTER: ALS_CONF_0 - 0x00			
REGISTER NAME	BIT	FUNCTION / DESCRIPTION	R / W
Reserved	7	Must be set to "0"	R / W
ALS_IT	6 : 4	ALS integration time setting 000 = 3.125 ms 001 = 6.25 ms 010 = 12.5 ms 011 = 25 ms 100 = 50 ms 101 = 100 ms 110 = 200 ms 111 = 400 ms	R / W
ALS_AF	3	Active force mode enable setting 0 = AF disable 1 = AF enable Once enabled, a single measurement can be triggered with the "ALS_TRIG" bit	R / W
ALS_TRIG	2	ALS active force trigger setting 0 = no active force mode trigger 1 = trigger active force mode This bit resets to "0" automatically after every trigger	R / W
ALS_INT_EN	1	ALS interrupt setting 0 = interrupt disable 1 = interrupt enable	R / W
SD	0	Band gap and LDO shutdown setting 0 = band gap and LDO on 1 = band gap and LDO shutdown (default)	R / W

Note

- Command code 0x00 default value is 0x01 = device is shutdown

**TABLE 2 - REGISTER: ALS_CONF_1 - 0x01**

REGISTER NAME	BIT	FUNCTION / DESCRIPTION	R / W
ALS_IR_SD	7	ALS and IR channel shutdown setting 0 = ALS and IR channels on 1 = ALS and IR channels shutdown	R / W
PD_DIV4	6	Effective photodiode size ALS and IR 0 = 4/4 PD used 1 = 1/4 PD used	R / W
Reserved	5	Reserved	R / W
ALS_GAIN	4 : 3	Gain selection 00 = ALS gain x1 01 = ALS gain x2 10 = ALS gain x 0.66 11 = ALS gain x 0.5	R / W
ALS_PERS	2 : 1	ALS persistence protect number setting Number of persistent measurements above threshold to trigger the interrupt 00 = 1 01 = 2 10 = 4 11 = 8	R / W
ALS_CAL	0	Must be set to "1" when power on ready	R / W

TABLE 3 - REGISTER: ALS_WH - 0x04, 0x05

COMMAND CODE	REGISTER NAME	BIT	FUNCTION / DESCRIPTION	R / W
0x04	ALS_WH_L	7 : 0	ALS high threshold window setting (data byte low)	R / W
0x05	ALS_WH_H	7 : 0	ALS high threshold window setting (data byte high)	R / W

TABLE 4 - REGISTER: ALS_WL - 0x06, 0x07

COMMAND CODE	REGISTER NAME	BIT	FUNCTION / DESCRIPTION	R / W
0x06	ALS_WL_L	7 : 0	ALS low threshold window setting (data byte low)	R / W
0x07	ALS_WL_H	7 : 0	ALS low threshold window setting (data byte high)	R / W

TABLE 5 - REGISTER: ALS_DATA - 0x10, 0x11

COMMAND CODE	REGISTER NAME	BIT	FUNCTION / DESCRIPTION	R / W
0x10	ALS_DATA_L	7 : 0	ALS result channel (data byte low)	R
0x11	ALS_DATA_H	7 : 0	ALS result channel (data byte high)	R

TABLE 6 - REGISTER: IR_DATA - 0x12, 0x13

COMMAND CODE	REGISTER NAME	BIT	FUNCTION / DESCRIPTION	R / W
0x12	IR_DATA_L	7 : 0	IR result channel (data byte low)	R
0x13	IR_DATA_H	7 : 0	IR result channel (data byte high)	R

TABLE 7 - REGISTER: ID - 0x14, 0x15

COMMAND CODE	REGISTER NAME	BIT	FUNCTION / DESCRIPTION	R / W
0x14	ID_L	7 : 0	ID code: 0x01	R
0x15	ID_H	7 : 6 5 : 4 3 : 0	Package code: 00 Slave address: 00 = 0x29; 01 = 0x10 Version code: 0000 = A01	R

**TABLE 8 - REGISTER: ALS_INT - 0x17**

REGISTER NAME	BIT	FUNCTION / DESCRIPTION	R / W
Reserved	7 : 4	Reserved	R
ALS_AF_DATA_READY	3	ALS active force mode data ready flag	R
ALS_IF_L	2	ALS low threshold INT flag	R
ALS_IF_H	1	ALS high threshold INT flag	R
Reserved	0	Reserved	R

CALCULATING THE LUX LEVEL

Command code 0x10 and 0x11 contain the results of the ALS measurement. This 16-bit code needs to be converted to a decimal value to determine the corresponding lux value. The calculation of the corresponding lux level is dependent on the programmed gain setting and the chosen integration time.

The component is most sensitive with ALS_GAIN = x2, PD_DIV4 = 4/4 and an integration time of 400 ms, specified to 0.0034 lx/step.

Every time the integration time is halved, the resolution is doubled but also the possible detection range is doubled.

The same principle is valid for the gain setting. For ALS_GAIN = x1 it is doubled. For PD_DIV4 = 1/4 the size of the photodiode is just 1/4, so, also the sensitivity is just 1/4, resolution and max. possible detection range is times 4, to allow for higher illuminations up to about 228 klx.

TABLE 9 - RESOLUTION AND MAXIMUM DETECTION RANGE AT PD_DIV4 = 0 (= x 4/4)

IT (ms)	GAIN x 2	GAIN x 1	GAIN x 0.66	GAIN x 0.5		GAIN x 2	GAIN x 1	GAIN x 0.66	GAIN x 0.5
	TYPICAL RESOLUTION (lx/cnt)					MAXIMUM POSSIBLE ILLUMINATION (lx)			
400	0.0034	0.0068	0.0103	0.0136		223	446	675	891
200	0.0068	0.0136	0.0206	0.0272		446	891	1350	1783
100	0.0136	0.0272	0.0412	0.0544		891	1783	2701	3565
50	0.0272	0.0544	0.0824	0.1088		1783	3565	5402	7130
25	0.0544	0.1088	0.1648	0.2176		3565	7130	10803	14260
12.5	0.1088	0.2176	0.3297	0.4352		7130	14260	21607	28521
6.25	0.2176	0.4352	0.6594	0.8704		14260	28521	43213	57042
3.125	0.4352	0.8704	1.3188	1.7408		(-) ⁽¹⁾	(-) ⁽¹⁾	(-) ⁽¹⁾	(-) ⁽¹⁾

TABLE 10 - RESOLUTION AND MAXIMUM DETECTION RANGE AT PD_DIV4 = 1 (= x 1/4)

IT (ms)	GAIN x 2	GAIN x 1	GAIN x 0.66	GAIN x 0.5		GAIN x 2	GAIN x 1	GAIN x 0.66	GAIN x 0.5
	TYPICAL RESOLUTION (lx/cnt)					MAXIMUM POSSIBLE ILLUMINATION (lx)			
400	0.0136	0.0272	0.0412	0.0544		891	1783	2701	3565
200	0.0272	0.0544	0.0824	0.1088		1783	3565	5402	7130
100	0.0544	0.1088	0.1648	0.2176		3565	7130	10803	14260
50	0.1088	0.2176	0.3297	0.4352		7130	14260	21607	28521
25	0.2176	0.4352	0.6594	0.8704		14260	28521	43213	57042
12.5	0.4352	0.8704	1.3188	1.7408		28521	57042	86427	114083
6.25	0.8704	1.7408	2.6376	3.4816		57042	114083	172854	228167
3.125	1.7408	3.4816	5.2752	6.9632		(-) ⁽¹⁾	(-) ⁽¹⁾	(-) ⁽¹⁾	(-) ⁽¹⁾

Note

⁽¹⁾ For integration time of 3.125 ms the maximum count level is no longer 16 bit, so, half the integration time no longer leads to double the max. lux level

Example:

If the 16-bit word of the ALS data shows: 0000 0101 1100 1000 = 1480 (dec.), the programmed ALS_GAIN = x1, PD_DIV4 = 4/4 (= x1) and ALS_IT = 100 ms, the corresponding lux level is: light level (lx) = 1480 x 0.0272 = 40.256 lx.

PACKAGE DIMENSIONS in millimeters

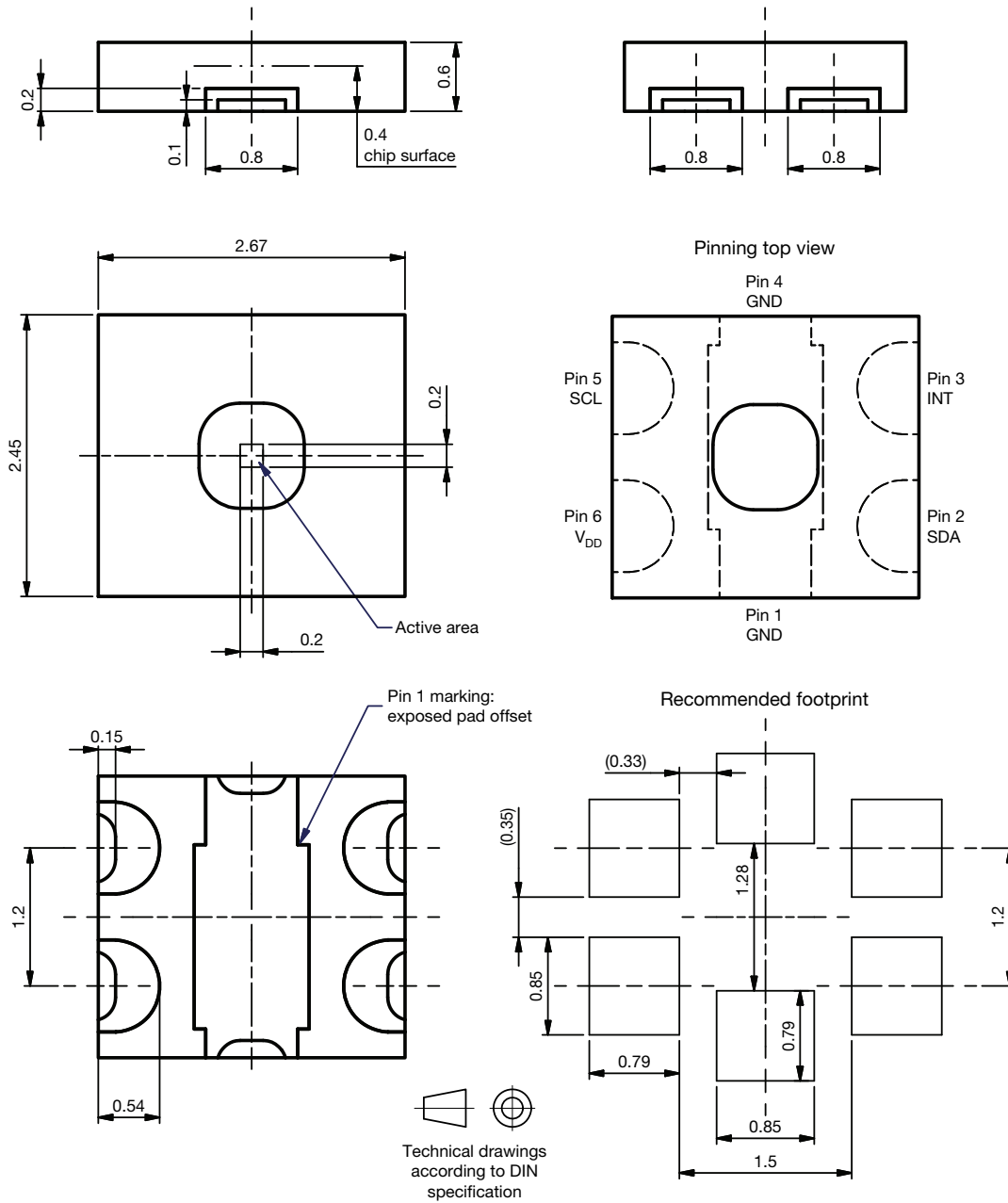

Drawing No.: 6.550-5357.01-4
Issue: 1; 14.04.2021

All dimensions in mm incl. burrs
Not indicated tolerances ± 0.1

MARKING AND PIN 1 IDENTIFICATION

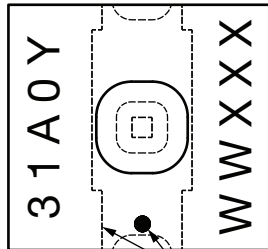

31: device type
 A: address option (0, 1)
 0: qualification (0 = AEC-Q100)
 Y: year
 WW: week
 XXX: lot number

Pin 1 marking
 dot marking on top side
 elongated feature on bottom side

TAPE AND REEL DIMENSIONS in millimeters

Reel size:
 VEML6031: \varnothing 180 mm \pm 2 mm = 3000 pcs.
 VEML6031-GS 15: \varnothing 330 mm \pm 2 mm = 10 000 pcs.
 Reel design is representative for different types.

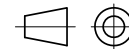

Technical drawings
 according to DIN
 specification

Not indicated tolerances \pm 0.1

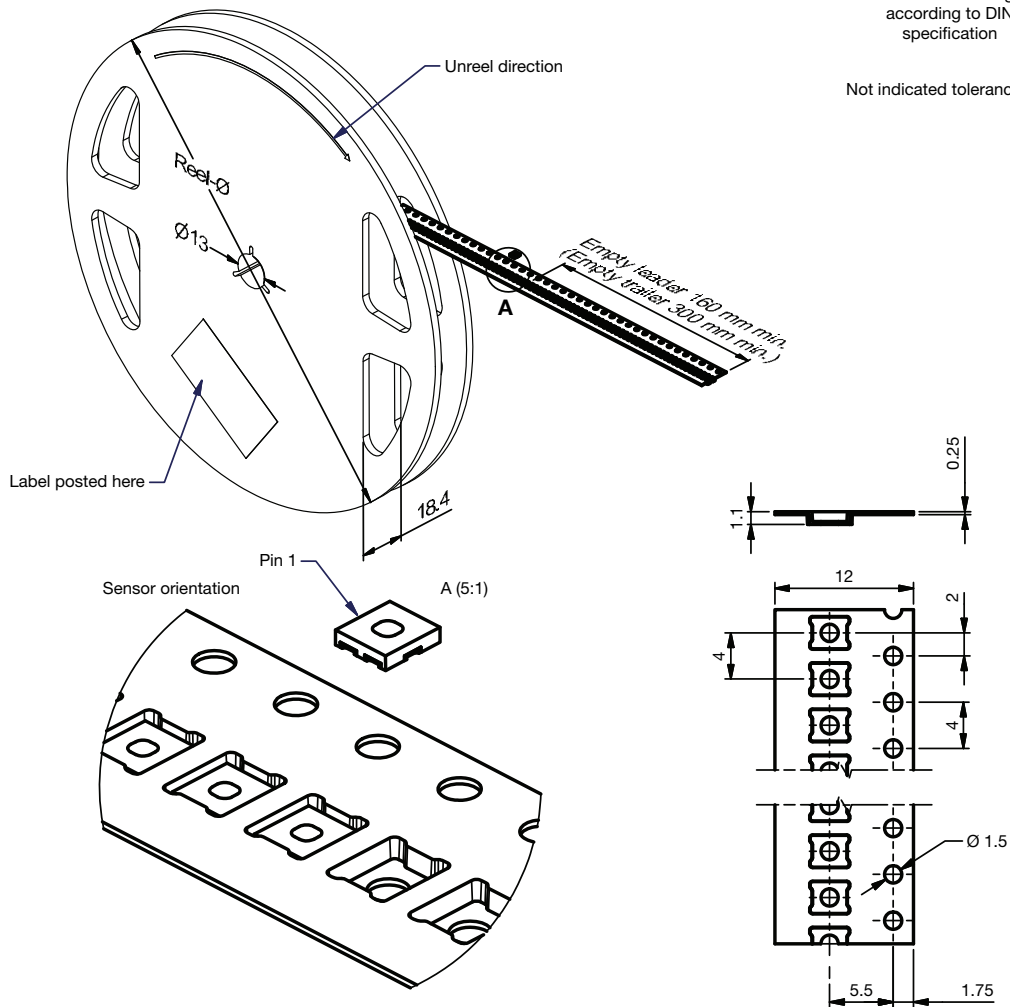

Drawing No.: 9.800-5148.01-4
 Issue: preliminary; 16.10.19



DRYPACK

Devices are packed in moisture barrier bags (MBB) to prevent the products from moisture absorption during transportation and storage. Each bag contains a desiccant.

FLOOR LIFE

Floor life (time between soldering and removing from MBB) must not exceed the time indicated on MBB label:

Floor life: 4 weeks

Conditions: $T_{amb} < 30\text{ }^{\circ}\text{C}$, RH < 60 %

Moisture sensitivity level 2a, according to J-STD-020.

DRYING

In case of moisture absorption devices should be baked before soldering. Conditions see J-STD-020 or label. Devices taped on reel dry using recommended conditions 192 h at 40 °C (+ 5 °C), RH < 5 %.

REFLOW SOLDER PROFILE

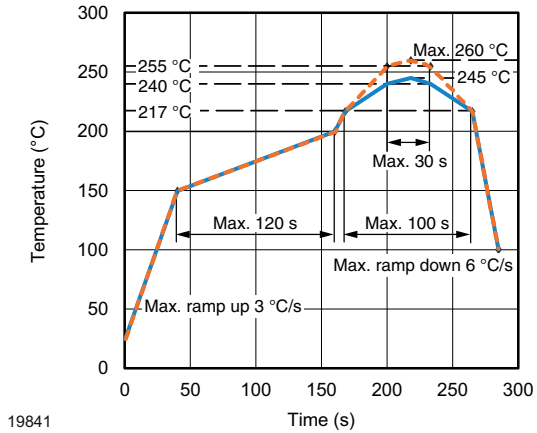

Fig. 13 - Lead (Pb)-free Reflow Solder Profile According to J-STD-020



Disclaimer

ALL PRODUCT, PRODUCT SPECIFICATIONS AND DATA ARE SUBJECT TO CHANGE WITHOUT NOTICE TO IMPROVE RELIABILITY, FUNCTION OR DESIGN OR OTHERWISE.

Vishay Intertechnology, Inc., its affiliates, agents, and employees, and all persons acting on its or their behalf (collectively, "Vishay"), disclaim any and all liability for any errors, inaccuracies or incompleteness contained in any datasheet or in any other disclosure relating to any product.

Vishay makes no warranty, representation or guarantee regarding the suitability of the products for any particular purpose or the continuing production of any product. To the maximum extent permitted by applicable law, Vishay disclaims (i) any and all liability arising out of the application or use of any product, (ii) any and all liability, including without limitation special, consequential or incidental damages, and (iii) any and all implied warranties, including warranties of fitness for particular purpose, non-infringement and merchantability.

Statements regarding the suitability of products for certain types of applications are based on Vishay's knowledge of typical requirements that are often placed on Vishay products in generic applications. Such statements are not binding statements about the suitability of products for a particular application. It is the customer's responsibility to validate that a particular product with the properties described in the product specification is suitable for use in a particular application. Parameters provided in datasheets and / or specifications may vary in different applications and performance may vary over time. All operating parameters, including typical parameters, must be validated for each customer application by the customer's technical experts. Product specifications do not expand or otherwise modify Vishay's terms and conditions of purchase, including but not limited to the warranty expressed therein.

Hyperlinks included in this datasheet may direct users to third-party websites. These links are provided as a convenience and for informational purposes only. Inclusion of these hyperlinks does not constitute an endorsement or an approval by Vishay of any of the products, services or opinions of the corporation, organization or individual associated with the third-party website. Vishay disclaims any and all liability and bears no responsibility for the accuracy, legality or content of the third-party website or for that of subsequent links.

Vishay products are not designed for use in life-saving or life-sustaining applications or any application in which the failure of the Vishay product could result in personal injury or death unless specifically qualified in writing by Vishay. Customers using or selling Vishay products not expressly indicated for use in such applications do so at their own risk. Please contact authorized Vishay personnel to obtain written terms and conditions regarding products designed for such applications.

No license, express or implied, by estoppel or otherwise, to any intellectual property rights is granted by this document or by any conduct of Vishay. Product names and markings noted herein may be trademarks of their respective owners.

Looking for pricing, stock, or lifecycle information?

Click below to explore more details on WIN SOURCE:

 [View VEMML6031X00 on WIN SOURCE](#)

 [Vishay Information](#)

Optimize Your Supply Chain with WIN SOURCE Solutions

-  Global Sourcing Solution
-  Obsolete Management
-  Cost Control Management
-  Shortage Management
-  Alternative Solution
-  Excess Inventory Management