



**THE DATASHEET OF
TPA3137D2PWP**



TPA3137D2 6-W Inductor Free Stereo (BTL) Class-D Audio Amplifier with Ultra Low EMI

1 Features

- 2 × 6 W/ch into 6-Ω loads at 10% THD+N from a 12-V supply
- 2 × 6 W/ch into 8-Ω loads at 10% THD+N from a 13-V supply
- Up to 90% Efficient class-D operation (8 Ω) eliminates need for heat sinks
- <0.05% THD+N at 1 W/4 Ω/1 kHz
- Wide supply voltage range allows operation from 4.5 V to 14.4 V
- Inductor-free operation
- Enhanced EMI performance with spread spectrum
- SpeakerGuard™ speaker protection includes power limiter and DC protection
- Robust pin-to-pin, pin-to-ground, and pin-to-power short circuit protection and thermal protection
- 26-dB Fixed gain
- Single-ended or differential analog inputs
- Click and pop free startup

2 Applications

- [Televisions](#)
- [Bluetooth, wireless speakers](#)
- [Mini speakers](#)
- [USB speakers](#)
- [Consumer audio equipment](#)

3 Description

The TPA3137D2 device is an efficient, Class-D audio power amplifier for driving bridged-tied stereo speakers at up to 6 W, 6 Ω, or 8 Ω (per channel).

Advanced EMI Suppression Technology with Spread Spectrum Control scheme enables the use of inexpensive ferrite bead filters at the outputs while meeting EMC requirements for system cost reduction. The TPA3137D2 device is not only fully protected against shorts and overload, the SpeakerGuard™ speaker protection circuitry includes a power limiter and a DC detection circuit for protection of the connected speakers. The DC detect and Pin-to-Pin, Pin-to-Ground, and Pin-to-Power Short Circuit protection circuit protect the speakers from output DC and pin shorts caused in production. The outputs are also fully protected against shorts to GND, PVCC, and output-to-output. The short-circuit protection and thermal protection includes an auto recovery feature.

The TPA3137D2 device can drive stereo speakers with as low as 4-Ω impedance. The high efficiency of the TPA3137D2, 90% with an 8-Ω load, eliminates the need for an external heat sink, and TPA3137D2 will be able to output full power on a 2-layer PCB.

Device Information⁽¹⁾

PART NUMBER	PACKAGE	BODY SIZE (NOM)
TPA3137D2	HTSSOP (28)	9.70 mm × 4.40 mm

(1) For all available packages, see the orderable addendum at the end of the datasheet.

Simplified Schematic

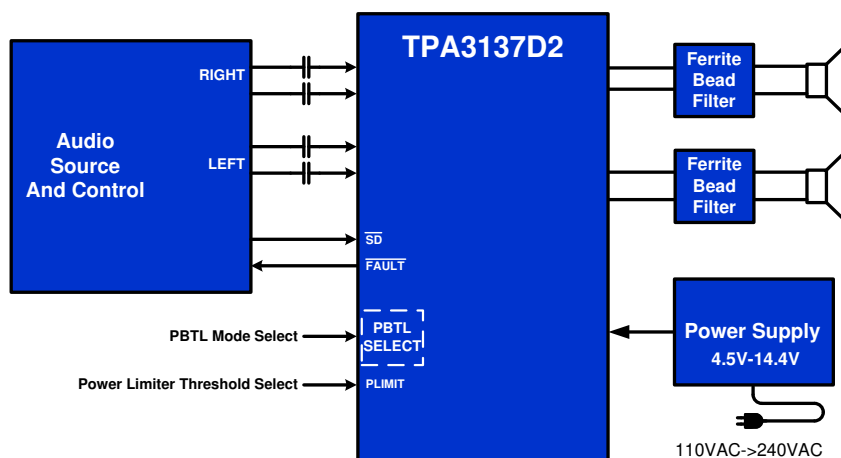

Table of Contents

1 Features	1	9.4 Device Functional Modes.....	15
2 Applications	1	10 Application and Implementation	16
3 Description	1	10.1 Application Information.....	16
4 Revision History	2	10.2 Typical Applications	16
5 Device Comparison Table	3	11 Power Supply Recommendations	23
6 Pin Configuration and Functions	3	11.1 Power Supply Decoupling, C _S	23
7 Specifications	5	12 Layout	24
7.1 Absolute Maximum Ratings	5	12.1 Layout Guidelines	24
7.2 ESD Ratings	5	12.2 Layout Example	25
7.3 Recommended Operating Conditions.....	5	13 Device and Documentation Support	26
7.4 Thermal Information	6	13.1 Device Support	26
7.5 Electrical Characteristics.....	6	13.2 Documentation Support	26
7.6 Switching Characteristics	6	13.3 Related Links	26
7.7 Typical Characteristics	7	13.4 Receiving Notification of Documentation Updates	26
8 Parameter Measurement Information	9	13.5 Support Resources	26
9 Detailed Description	10	13.6 Trademarks	26
9.1 Overview	10	13.7 Electrostatic Discharge Caution.....	26
9.2 Functional Block Diagram	11	13.8 Glossary	26
9.3 Feature Description.....	12	14 Mechanical, Packaging, and Orderable Information	27

4 Revision History

NOTE: Page numbers for previous revisions may differ from page numbers in the current version.

Changes from Revision B (December 2017) to Revision C	Page
• Changed the <i>Functional Block Diagram</i> , missing and unconnected lines	11

Changes from Revision A (June 2016) to Revision B	Page
• Changed the Supply Voltage (AVCC to GND, PVCC to GND) MAX value From: 16 V To: 20 V in the <i>Absolute Maximum Ratings</i>	5

Changes from Original (June 2016) to Revision A	Page
• Changed '2 × 8 W/ch' to '2 × 6 W/ch' for 6-Ω load in Features.....	1
• Changed 8 W to 6 W in Description.	1
• Updated Thermal Characteristics	6

5 Device Comparison Table

DEVICE NAME	DESCRIPTION
TPA3113D2	6-W Filter-Free Class-D Stereo Amplifier with SpeakerGuard™
TPA3144D2	6-W Inductor-Free Class-D Stereo Amplifier with Ultra Low EMI and AGL

6 Pin Configuration and Functions

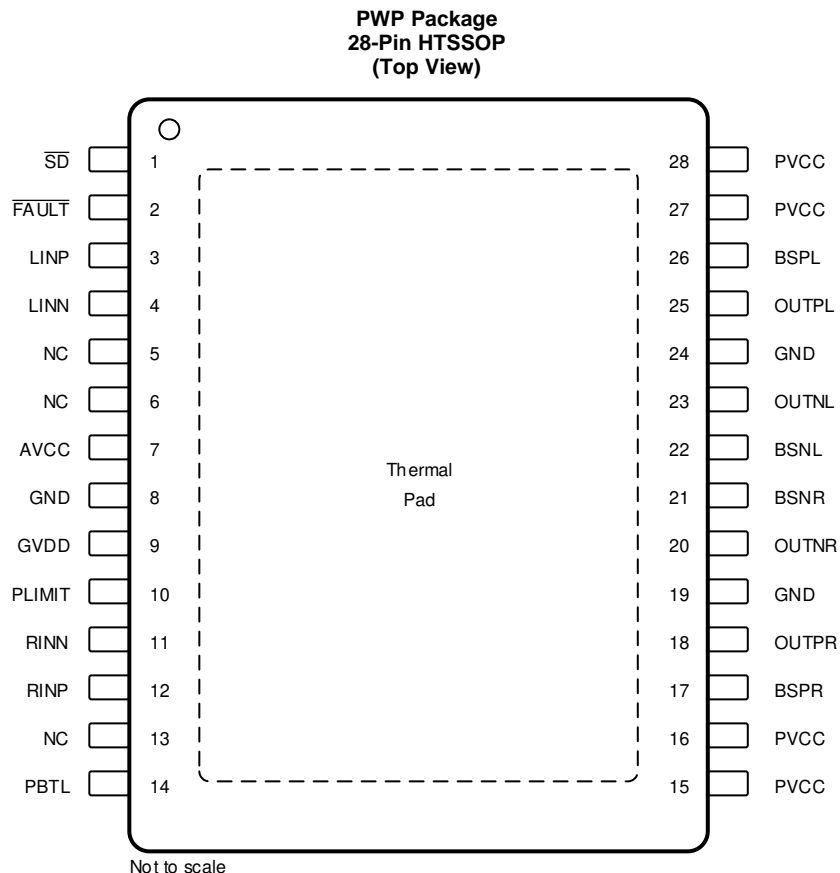

Pin Functions

PIN		I/O/P ⁽¹⁾	DESCRIPTION
NAME	NUMBER		
\overline{SD}	1	I	Shutdown logic input for audio amp (LOW = outputs Hi-Z, HIGH = outputs enabled). TTL logic levels with compliance to AVCC.
\overline{FAULT}	2	O	Open drain output used to display short circuit or dc detect fault status. Voltage compliant to AVCC. Short circuit faults can be set to auto-recovery by connecting FAULT pin to SD pin. Otherwise, both short circuit faults and dc detect faults must be reset by cycling PVCC.
LINP	3	I	Positive audio input for left channel. Biased at 3 V.
LINN	4	I	Negative audio input for left channel. Biased at 3 V.
NC	5, 6, 13	I	No Connect Pin. Can be shorted to PVCC or shorted to GND or left open.
AVCC	7	P	Analog supply
GND	8	P	Analog signal ground.

(1) I = Input, O = Output, P = Power

Pin Functions (continued)

PIN		I/O/P ⁽¹⁾	DESCRIPTION
NAME	NUMBER		
GVDD	9	O	High-side FET gate drive supply. Nominal voltage is 7 V.
PLIMIT	10	I	Power Limiter Control pin
RINN	11	I	Negative audio input for right channel. Biased at 3 V.
RINP	12	I	Positive audio input for right channel. Biased at 3 V.
PBTL	14	I	Parallel BTL mode select pin. L=Stereo BTL mode, H=Mono PBTL mode
PVCC	15, 16	P	Power supply for right channel H-bridge. Right channel and left channel power supply inputs are connected internally.
BSPR	17	I	Bootstrap I/O for right channel, positive high-side FET.
OUTPR	18	O	Class-D H-bridge positive output for right channel.
GND	19	P	Power ground for the H-bridges.
OUTNR	20	O	Class-D H-bridge negative output for right channel.
BSNR	21	I	Bootstrap I/O for right channel, negative high-side FET.
BSNL	22	I	Bootstrap I/O for left channel, negative high-side FET.
OUTNL	23	O	Class-D H-bridge negative output for left channel.
GND	24	P	Power ground for the H-bridges.
OUTPL	25	O	Class-D H-bridge positive output for left channel.
BSPL	26	I	Bootstrap I/O for left channel, positive high-side FET.
PVCC	27, 28	P	Power supply for left channel H-bridge. Right channel and left channel power supply inputs are connected internally.
Thermal Pad		P	Connect to GND for best thermal and electrical performance.

7 Specifications

7.1 Absolute Maximum Ratings

over operating free-air temperature range (unless otherwise noted)⁽¹⁾

		MIN	MAX	UNIT
Supply voltage	AVCC to GND, PVCC to GND	-0.3	20	V
Input current	To any pin except supply pins		10	mA
Voltage	\overline{SD} , \overline{FAULT} to GND ⁽²⁾	-0.3	AVCC + 0.3	V
			10	V/ms
Voltage	RINN, RINP, LINN, LINP	-0.3	6.3	V
Minimum load resistance, R_L	BTL, PVCC > 12 V	4.8		Ω
	BTL, PVCC \leq 12 V	3.2		
	PBTL, PVCC > 12 V	2.5		
	PBTL, PVCC \leq 12 V	1.8		
Continuous total power dissipation		See the Thermal Information Table		
Operating free-air temperature range, T_A ⁽³⁾		-40	85	$^{\circ}\text{C}$
Temperature range		-65	150	$^{\circ}\text{C}$
Storage temperature range, T_{stg}		-65	150	$^{\circ}\text{C}$

- (1) Stresses beyond those listed under *Absolute Maximum Ratings* may cause permanent damage to the device. These are stress ratings only, which do not imply functional operation of the device at these or any other conditions beyond those indicated under *Recommended Operating Conditions*. Exposure to absolute-maximum-rated conditions for extended periods may affect device reliability.
- (2) The voltage slew rate of these pins must be restricted to no more than 10 V/ms. For higher slew rates, use a 100 k Ω resistor in series with the pins.
- (3) The TPA3137D2 incorporates an exposed thermal pad on the underside of the chip. This acts as a heatsink, and it must be connected to a thermally dissipating plane for proper power dissipation. Failure to do so may result in the device going into thermal protection shutdown. See TI Technical Briefs [SLMA002](#) for more information about using the TSSOP thermal pad.

7.2 ESD Ratings

		VALUE	UNIT
$V_{(ESD)}$ Electrostatic discharge	Human body model (HBM), per ANSI/ESDA/JEDEC JS-001 ⁽¹⁾	± 1000	V
	Charged device model (CDM), per JEDEC specification JESD22-C101 ⁽²⁾	± 250	

- (1) JEDEC document JEP155 states that 500-V HBM allows safe manufacturing with a standard ESD control process.
- (2) JEDEC document JEP157 states that 250-V CDM allows safe manufacturing with a standard ESD control process.

7.3 Recommended Operating Conditions

over operating free-air temperature range (unless otherwise noted)

PARAMETER	TEST CONDITIONS	MIN	MAX	UNIT
V_{CC} Supply voltage	PVCC, AVCC	4.5	14.4	V
V_{IH} High-level input voltage	\overline{SD} , PBTL	2	AVCC	V
V_{IL} Low-level input voltage	\overline{SD} , PBTL		0.8	V
V_{OL} Low-level output voltage	\overline{FAULT} , $R_{PULL-UP}=100\text{ k}$, PVCC=14.4 V		0.8	V
I_{IH} High-level input current	\overline{SD} , PBTL, $V_I = 2\text{ V}$, AVCC = 12 V		50	μA
I_{IL} Low-level input current	\overline{SD} , PBTL, $V_I = 0.8\text{ V}$, AVCC = 12 V		5	μA
T_A Operating free-air temperature ⁽¹⁾		-40	85	$^{\circ}\text{C}$
T_J Operating junction temperature ⁽¹⁾		-40	150	$^{\circ}\text{C}$

- (1) The TPA3137D2 incorporates an exposed thermal pad on the underside of the chip. This acts as a heatsink, and it must be connected to a thermally dissipating plane for proper power dissipation. Failure to do so may result in the device going into thermal protection shutdown. See TI Technical Briefs [SLMA002](#) for more information about using the TSSOP thermal pad.

7.4 Thermal Information

THERMAL METRIC ⁽¹⁾		TPA3137D2	UNIT
		PWP (HTSSOP)	
		28 PINS	
$R_{\theta JA}$	Junction-to-ambient thermal resistance	30.3	°C/W
$R_{\theta JC(top)}$	Junction-to-case (top) thermal resistance	33.5	°C/W
$R_{\theta JB}$	Junction-to-board thermal resistance	17.5	°C/W
ψ_{JT}	Junction-to-top characterization parameter	0.9	°C/W
ψ_{JB}	Junction-to-board characterization parameter	7.2	°C/W
$R_{\theta JC(bot)}$	Junction-to-case (bottom) thermal resistance	0.9	°C/W

(1) For more information about traditional and new thermal metrics, see the [Semiconductor and IC Package Thermal Metrics](#) application report.

7.5 Electrical Characteristics

$T_A = 25^\circ\text{C}$, $AV_{CC} = PV_{CC} = 12\text{ V}$, $R_L = 6\ \Omega$ (unless otherwise noted).⁽¹⁾ Over operating free-air temperature range (unless otherwise noted)

PARAMETER		TEST CONDITIONS	MIN	TYP	MAX	UNIT
DC CHARACTERISTICS						
$ V_{OS} $	Class-D output offset voltage (measured differentially)	$V_I = 0\text{ V}$, Gain = 26 dB		1.5	15	mV
I_{CC}	Quiescent supply current	$\overline{SD} = 2\text{ V}$, no load, 300 ohm Ferrite Bead + 1nF Output Filter		35	40	mA
$I_{CC(SD)}$	Quiescent supply current in shutdown mode	$\overline{SD} = 0.8\text{ V}$, no load		40	60	μA
$r_{DS(on)}$	Drain-source on-state resistance	$I_O = 500\text{ mA}$, $T_J = 25^\circ\text{C}$ Excluding Metal and Bond Wire Resistance				m Ω
		High Side		240		
		Low side		240		
G	Gain		25	26	27	dB
t_{on}	Turn-on time	$\overline{SD} = 2\text{ V}$		14		ms
t_{OFF}	Turn-off time	$\overline{SD} = 0.8\text{ V}$		2.5		μs
GVDD	Gate drive supply	$I_{GVDD} = 2\text{ mA}$	6.4	6.9	7.4	V
t_{DCDET}	DC detect time	$V_{RINN} = 3.1\text{ V}$ and $V_{RINN} = 2.9\text{ V}$, or $V_{RINN} = 2.9\text{ V}$ and $V_{RINN} = 3.1\text{ V}$		950		ms
AC CHARACTERISTICS						
PSRR	Power supply ripple rejection	200-mV _{PP} ripple at 1 kHz, Gain = 26 dB, Inputs ac-coupled to GND		-65		dB
P_O	Continuous output power	THD+N = 10%, $f = 1\text{ kHz}$		6		W
P_O	Continuous output power	THD+N = 10%, $f = 1\text{ kHz}$, $PV_{CC} = 13\text{ V}$, $R_L = 8\ \Omega$		6		W
P_O	Continuous output power, PBTL (mono)	THD+N = 10%, $f = 1\text{ kHz}$, $PV_{CC} = 13\text{ V}$, $R_L = 4\ \Omega$		12		W
THD+N	Total harmonic distortion + noise	$f = 1\text{ kHz}$, $P_O = 5\text{ W}$ (half-power)		0.06%		
V_n	Output integrated noise	20 Hz to 22 kHz, A-weighted filter, Gain = 26 dB		91		μV
	Crosstalk	$V_O = 1\text{ V}_{rms}$, Gain = 26 dB, $f = 1\text{ kHz}$		-81		dBV
				-75		dB
SNR	Signal-to-noise ratio	Maximum output at THD+N < 1%, $f = 1\text{ kHz}$, Gain = 26 dB, A-weighted		102		dB
OTE	Thermal trip point			150		°C
	Thermal hysteresis			15		°C

(1) Using the TPA3137D2 EVM (SLOU444), unless otherwise noted.

7.6 Switching Characteristics

over operating free-air temperature range (unless otherwise noted)

PARAMETER		MIN	NOM	MAX	UNIT
$f_{OSC, SS}$	Oscillator frequency, Spread Spectrum ON	255	315	355	kHz

7.7 Typical Characteristics

All Measurements taken at 26dB closed loop gain, 1-kHz audio, $T_A = 25^\circ\text{C}$ unless otherwise noted. Measurements were made with AES17 filter using the TPA3137D2 EVM, which is available at ti.com.

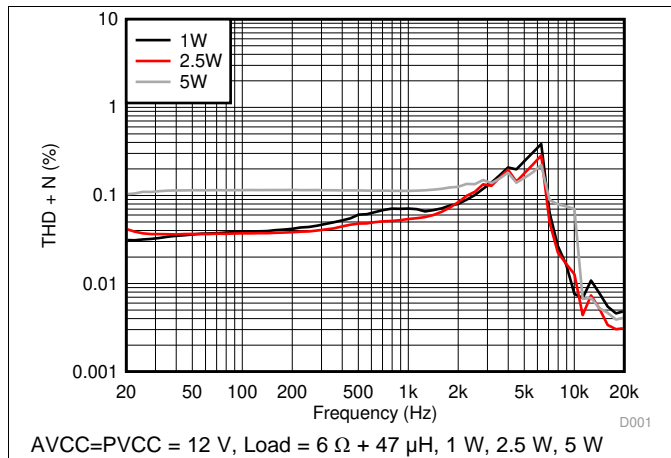

Figure 1. Total Harmonic Distortion vs Frequency (BTL)

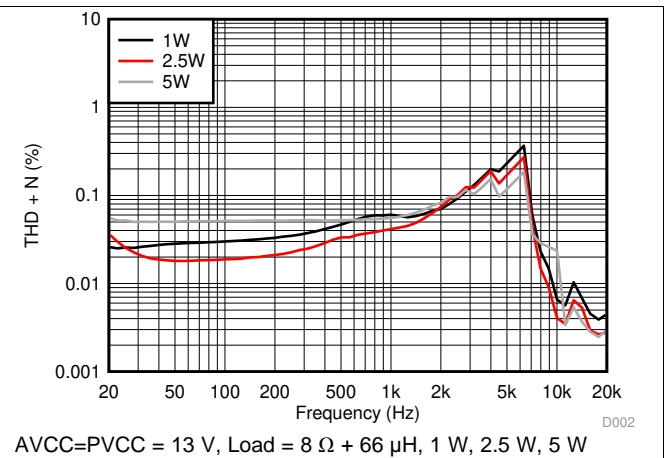

Figure 2. Total Harmonic Distortion vs Frequency (BTL)

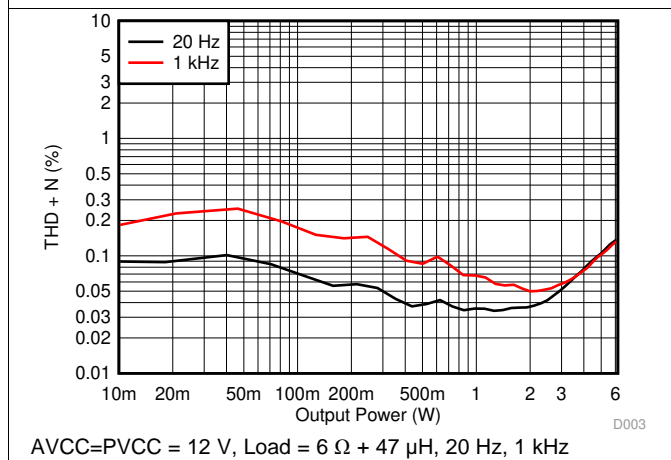

Figure 3. Total Harmonic Distortion + Noise vs Output Power (BTL)

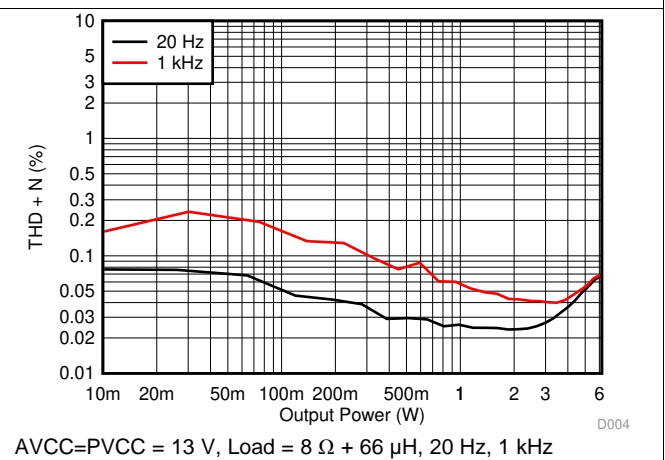

Figure 4. Total Harmonic Distortion + Noise vs Output Power (BTL)

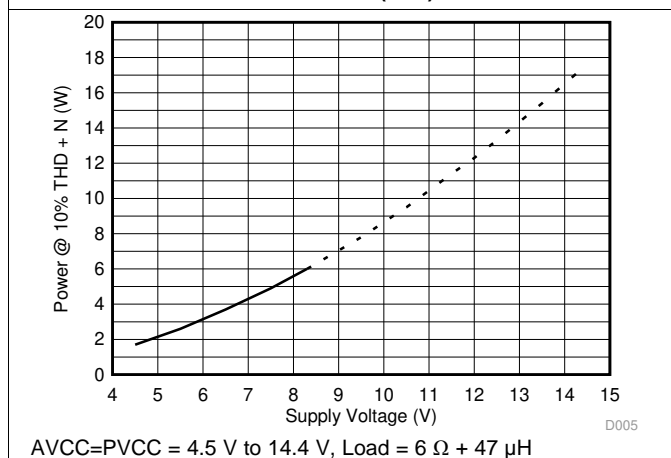

Figure 5. Output Power vs Supply Voltage (BTL)

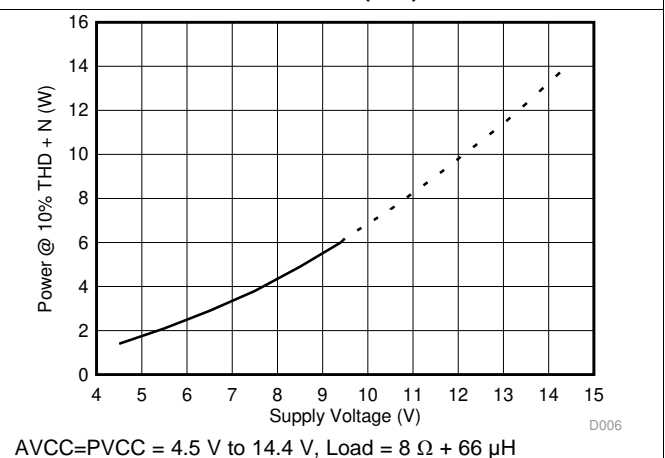

Figure 6. Output Power vs Supply Voltage (BTL)

Typical Characteristics (continued)

All Measurements taken at 26dB closed loop gain, 1-kHz audio, $T_A = 25^\circ\text{C}$ unless otherwise noted. Measurements were made with AES17 filter using the TPA3137D2 EVM, which is available at ti.com.

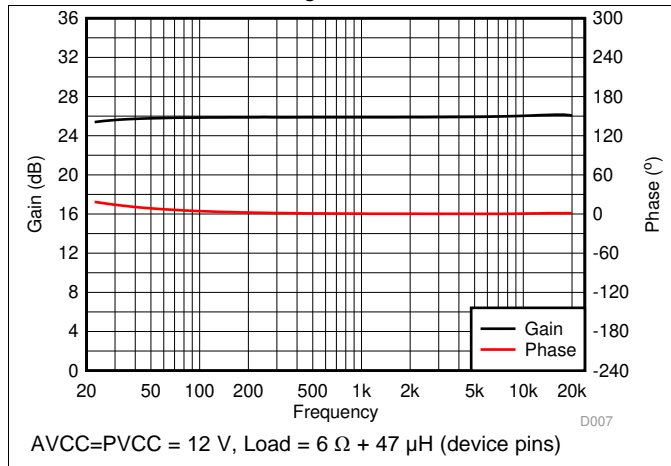

Figure 7. Gain/Phase vs Frequency (BTL)

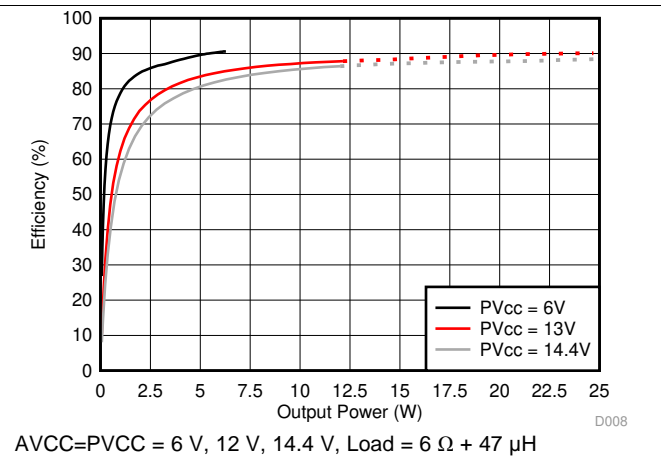

Figure 8. Efficiency vs Output Power (BTL)

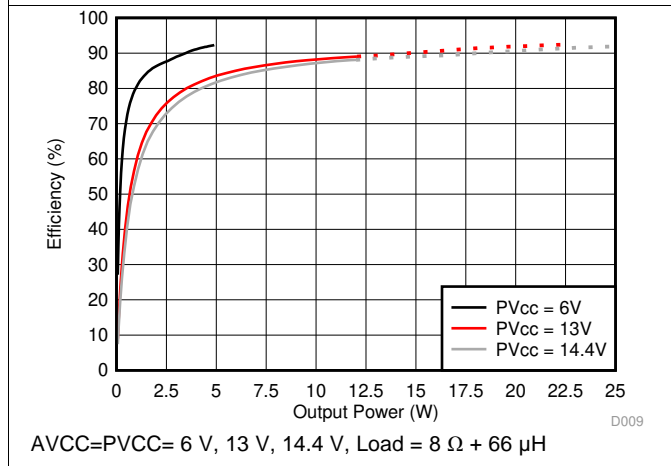

Figure 9. Efficiency vs Output Power (BTL)

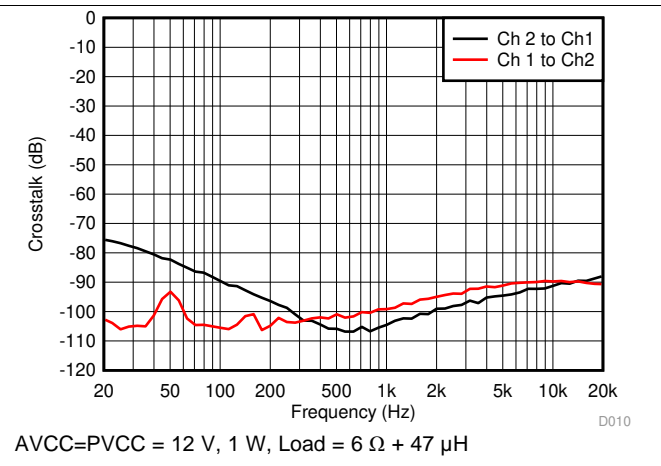

Figure 10. Crosstalk vs Frequency (BTL)

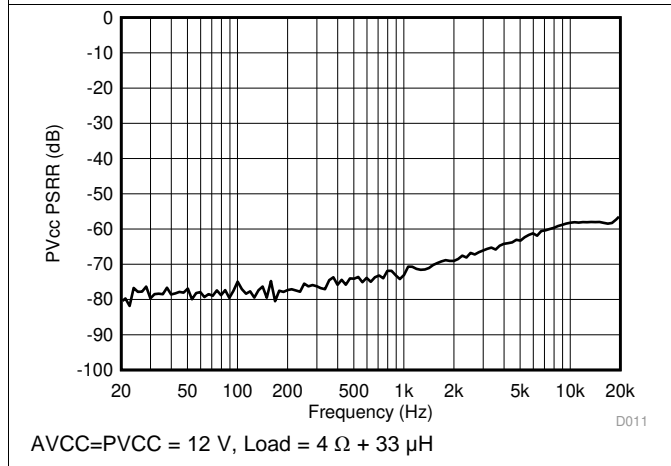

Figure 11. Supply Ripple Rejection Ratio vs Frequency (BTL)

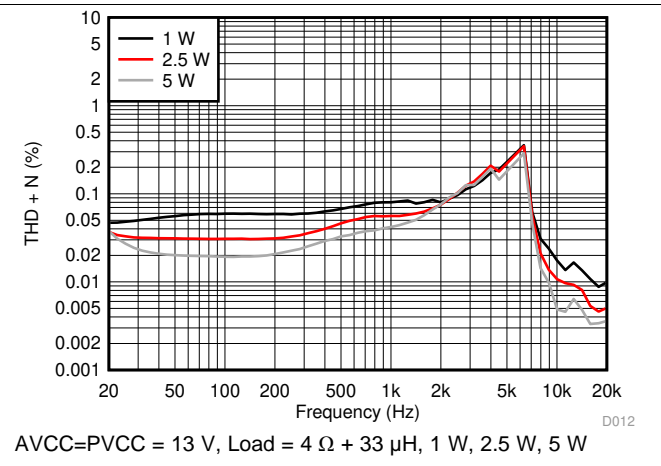
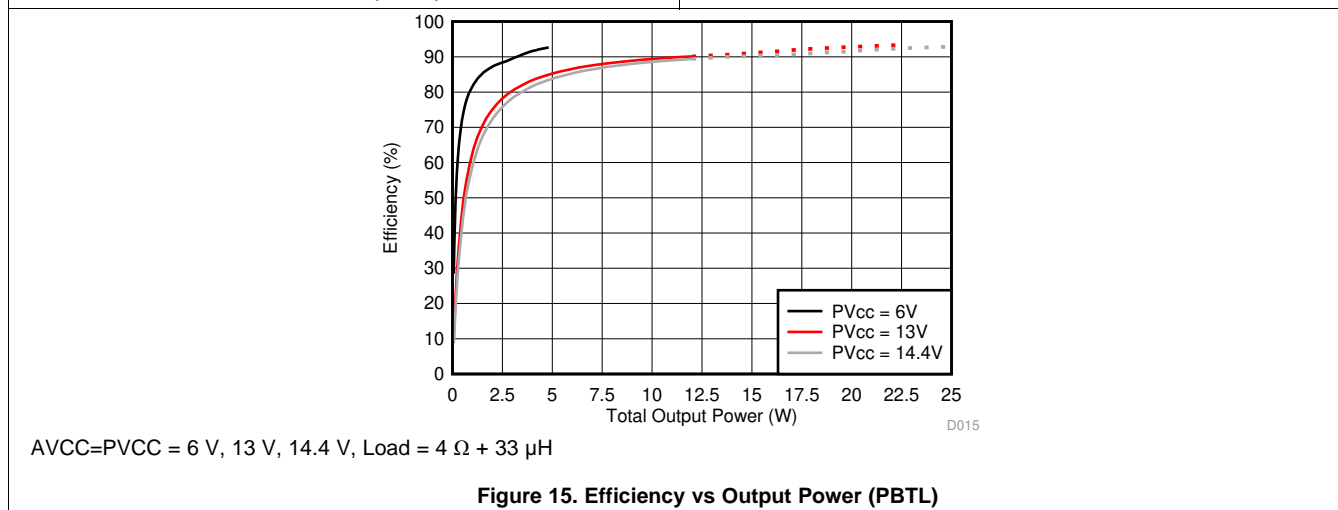
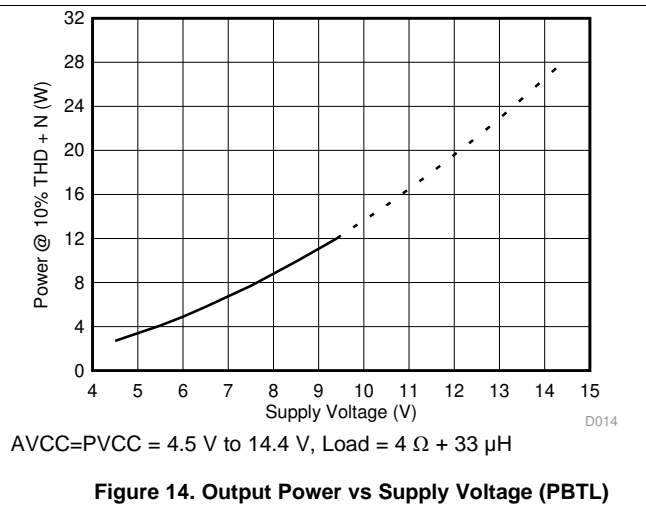
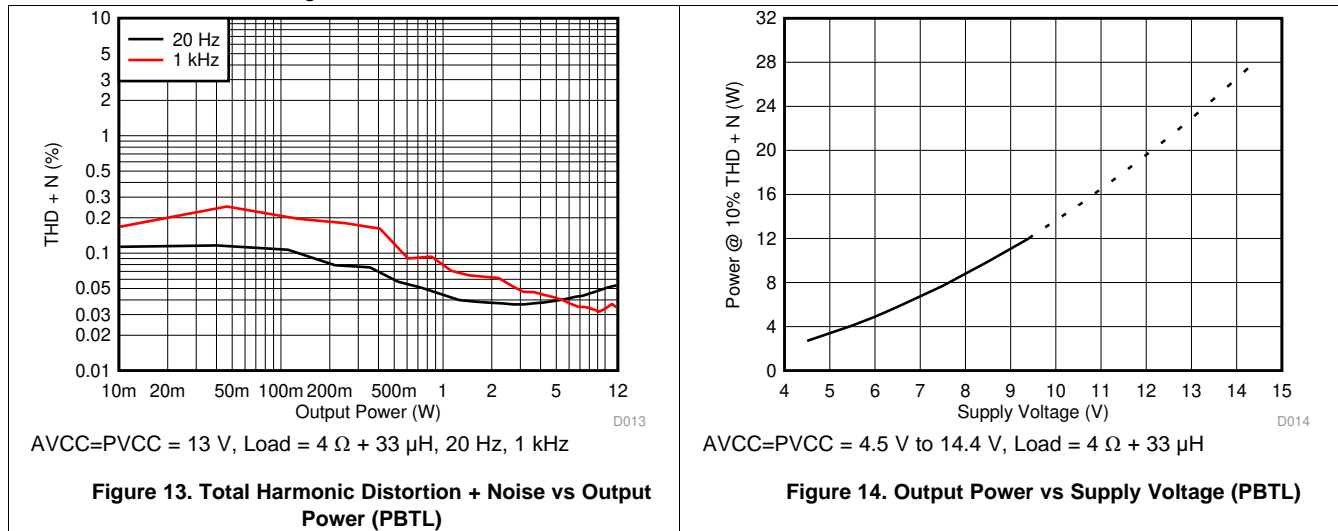

Figure 12. Total Harmonic Distortion + Noise vs Frequency (PBTL)

Typical Characteristics (continued)

All Measurements taken at 26dB closed loop gain, 1-kHz audio, $T_A = 25^\circ\text{C}$ unless otherwise noted. Measurements were made with AES17 filter using the TPA3137D2 EVM, which is available at ti.com.



8 Parameter Measurement Information

All parameters are measured according to the conditions described in the [Specifications](#) section.

Most audio analyzers will not give correct readings of Class-D amplifiers' performance due to their sensitivity to out of band noise present at the amplifier output. An AES-17 pre analyzer filter is recommended to use for Class-D amplifier measurements. In absence of such filter, a 30-kHz low-pass filter (10 Ω + 47 nF) can be used to reduce the out of band noise remaining on the amplifier outputs.

9 Detailed Description

9.1 Overview

To facilitate system design, the TPA3137D2 needs only a single power supply between 4.5 V and 14.4 V for operation. An internal voltage regulator provides suitable voltage levels for the gate driver, digital, and low-voltage analog circuitry. Additionally, all circuitry requiring a floating voltage supply, as in the high-side gate drive, is accommodated by built-in bootstrap circuitry with integrated boot strap diodes requiring only an external capacitor for each half-bridge.

The audio signal path, including the gate drive and output stage, is designed as identical, independent full-bridges. All decoupling capacitors should be placed as close to their associated pins as possible. In general, the physical loop with the power supply pins, decoupling capacitors and GND return path to the device pins must be kept as short as possible and with as little area as possible to minimize induction (see reference board documentation for additional information).

For a properly functioning bootstrap circuit, a small ceramic capacitor must be connected from each bootstrap pin (BSXX) to the power-stage output pin (OUTXX). When the power-stage output is low, the bootstrap capacitor is charged through an internal diode connected between the gate-drive power-supply pin (GVDD) and the bootstrap pins. When the power-stage output is high, the bootstrap capacitor potential is shifted above the output potential and thus provides a suitable voltage supply for the high-side gate driver. In an application with PWM switching frequencies in the range of 315 kHz, use ceramic capacitors with at least 220-nF capacitance, size 0603 or 0805, for the bootstrap supply. These capacitors ensure sufficient energy storage, even during clipped low frequency audio signals, to keep the high-side power stage FET (LDMOS) fully turned on during the remaining part of its ON cycle.

Special attention should be paid to the power-stage power supply; this includes component selection, PCB placement, and routing. For optimal electrical performance, EMI compliance, and system reliability, each PVCC pin should be decoupled with ceramic capacitors that are placed as close as possible to each supply pin. It is recommended to follow the PCB layout of the TPA3137D2 reference design. For additional information on recommended power supply and required components, see the application diagrams in this data sheet.

The PVCC power supply should have low output impedance and low noise. The power-supply ramp and \overline{SD} release sequence is not critical for device reliability as facilitated by the internal power-on-reset circuit, but it is recommended to release \overline{SD} after the power supply is settled for minimum turn on audible artifacts.

9.2 Functional Block Diagram

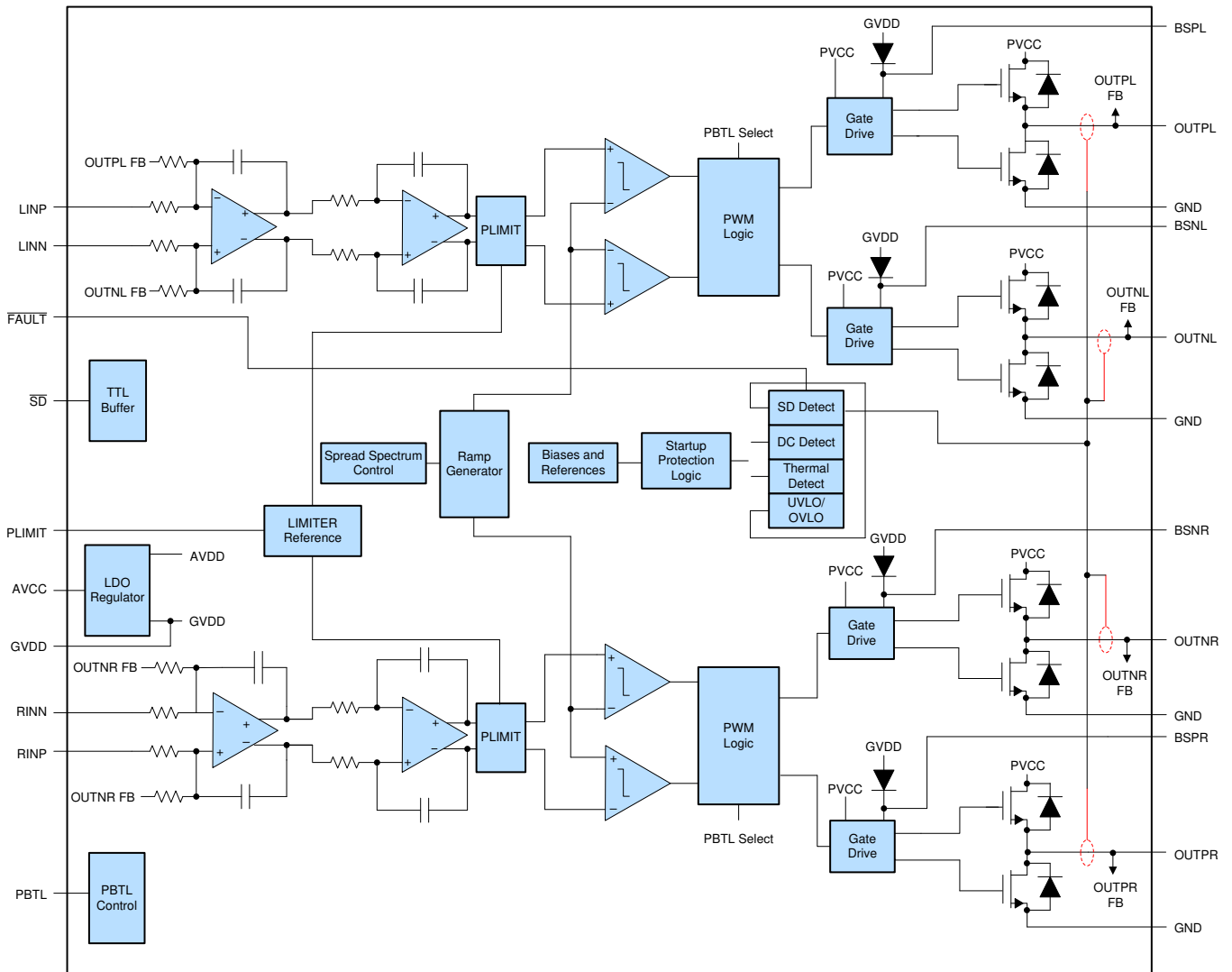

9.3 Feature Description

9.3.1 Fixed Analog Gain

The analog gain of the TPA3137D2 is fixed to 26 dB.

9.3.2 \overline{SD} Operation

The TPA3137D2 device employs a shutdown mode of operation designed to reduce supply current (I_{CC}) to the absolute minimum level during periods of nonuse for power conservation. The \overline{SD} input pin should be held high (see specification table for trip point) during normal operation when the amplifier is in use. Pulling \overline{SD} low causes the outputs to mute and the amplifier to enter a low-current state. Never leave \overline{SD} unconnected, because amplifier operation would be unpredictable.

For the best power-off pop performance, place the amplifier in the shutdown mode prior to removing the power supply voltage.

9.3.3 PLIMIT

The PLIMIT operation will, if selected, limit the output voltage level to a voltage level below the supply rail. In this case, the amplifier operates as if it was powered by a lower supply voltage, and thereby limiting the output power by voltage clipping. PLIMIT threshold is set by the PLIMIT pin voltage.

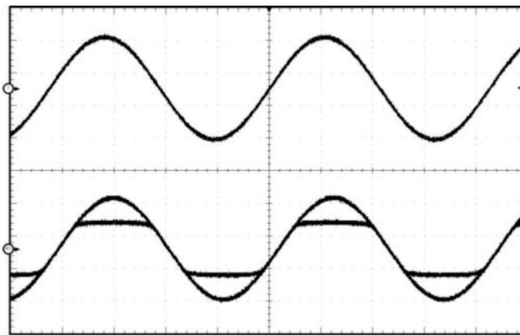

Figure 16. PLIMIT Circuit Operation

The PLIMIT circuit sets a limit on the output peak-to-peak voltage. The limiting is done by limiting the duty cycle to a fixed maximum value. The limit can be thought of as a "virtual" voltage rail which is lower than the supply connected to PVCC. The "virtual" rail is approximately four times the voltage at the PLIMIT pin. The output voltage can be used to calculate the maximum output power for a given maximum input voltage and speaker impedance.

Feature Description (continued)

$$P_{OUT} = \frac{\left(\left(\frac{R_L}{R_L + 2 \times R_S} \right) \times V_P \right)^2}{2 \times R_L} \quad \text{for unclipped power}$$

where

- $P_{OUT} (10\%THD) = 1.25 \times P_{OUT} (\text{unclipped})$
- R_L is the load resistance.
- R_S is the total series resistance including $R_{DS(on)}$, and output filter resistance.
- V_P is the peak amplitude, which is limited by "virtual" voltage rail. (1)

9.3.4 Spread Spectrum and De-Phase Control

The TPA3137D2 device has built-in spread spectrum control of the oscillator frequency and de-phase of the PWM outputs to improve EMI performance. The spread spectrum schemes is internally fixed is always turned on.

De-phase inverts the phase of the output PWM such that the idle output PWM waveforms of the two audio channels are inverted. De-phase does not affect the audio signal, or its polarity.

9.3.5 GVDD Supply

The GVDD Supply is used to power the gates of the output full bridge transistors. Add a 1- μ F capacitor to ground at this pin.

9.3.6 DC Detect

The TPA3137D2 device has circuitry which will protect the speakers from DC current which might occur due to defective capacitors on the input or shorts on the printed circuit board at the inputs. A DC detect fault will be reported on the \overline{FAULT} pin as a low state. The DC Detect fault will also cause the amplifier to shutdown by changing the state of the outputs to Hi-Z.

A DC Detect Fault is issued when the output differential duty-cycle of either channel exceeds 14% (for example, +57%, -43%) for more than 950 msec at the same polarity. This feature protects the speaker from large DC currents or AC currents less than 2 Hz. To avoid nuisance faults due to the DC detect circuit, hold the \overline{SD} pin low at power-up until the signals at the inputs are stable. Also, take care to match the impedance seen at the positive and negative inputs to avoid nuisance DC detect faults.

The minimum differential input voltage required to trigger the DC detect is 130 mV. The inputs must remain at or above the voltage listed in the table for more than 950 msec to trigger the DC detect.

9.3.7 PBTL Select

The TPA3137D2 device offers the feature of parallel BTL operation with two outputs of each channel connected directly. If the PBTL (pin 14) is tied high, the positive and negative outputs of each channel (left and right) are synchronized and in phase. To operate in this PBTL (mono) mode, tie PBTL pin to VCC and apply the input signal to the RINP and RINN inputs and place the speaker between the LEFT and RIGHT outputs with OUTPL connected to OUTNL and OUTPR connected to OUTNR to parallel the output half bridges for highest power efficiency. For an example of the PBTL connection, see the schematic in the [Typical Applications](#) section.

9.3.8 Short-Circuit Protection and Automatic Recovery Feature

The TPA3137D2 device has protection from overcurrent conditions caused by a short circuit on the output stage. The short circuit protection fault is reported on the \overline{FAULT} pin as a low state. The amplifier outputs are switched to a Hi-Z state when the short circuit protection latch is engaged. The latch can be cleared by cycling the \overline{SD} pin through the low state.

If automatic recovery from the short circuit protection latch is desired, connect the \overline{FAULT} pin directly to the \overline{SD} pin. This allows the \overline{FAULT} pin function to automatically drive the \overline{SD} pin low which clears the short-circuit protection latch.

Feature Description (continued)

9.3.9 Thermal Protection

Thermal protection on the TPA3137D2 device prevents damage to the device when the internal die temperature exceeds 150°C. There is a $\pm 15^\circ\text{C}$ tolerance on this trip point from device to device. Once the die temperature exceeds the thermal trip point, the device enters into the shutdown state and the outputs are disabled. This is a latched fault.

Thermal protection faults are reported on the $\overline{\text{FAULT}}$ pin.

If automatic recovery from the thermal protection latch is desired, connect the $\overline{\text{FAULT}}$ pin directly to the $\overline{\text{SD}}$ pin. This allows the $\overline{\text{FAULT}}$ pin function to automatically drive the $\overline{\text{SD}}$ pin low which clears the thermal protection latch.

9.4 Device Functional Modes

The TPA3137D2 device is running in **BD-modulation**.

This is a modulation scheme that allows operation without the classic LC reconstruction filter when the amp is driving an inductive load with short speaker wires. Each output is switching from 0 volts to the supply voltage. The OUTPx and OUTNx are in phase with each other with no input so that there is little or no current in the speaker. The duty cycle of OUTPx is greater than 50% and OUTNx is less than 50% for positive output voltages. The duty cycle of OUTPx is less than 50% and OUTNx is greater than 50% for negative output voltages. The voltage across the load sits at 0 V throughout most of the switching period, reducing the switching current, which reduces any I²R losses in the load.

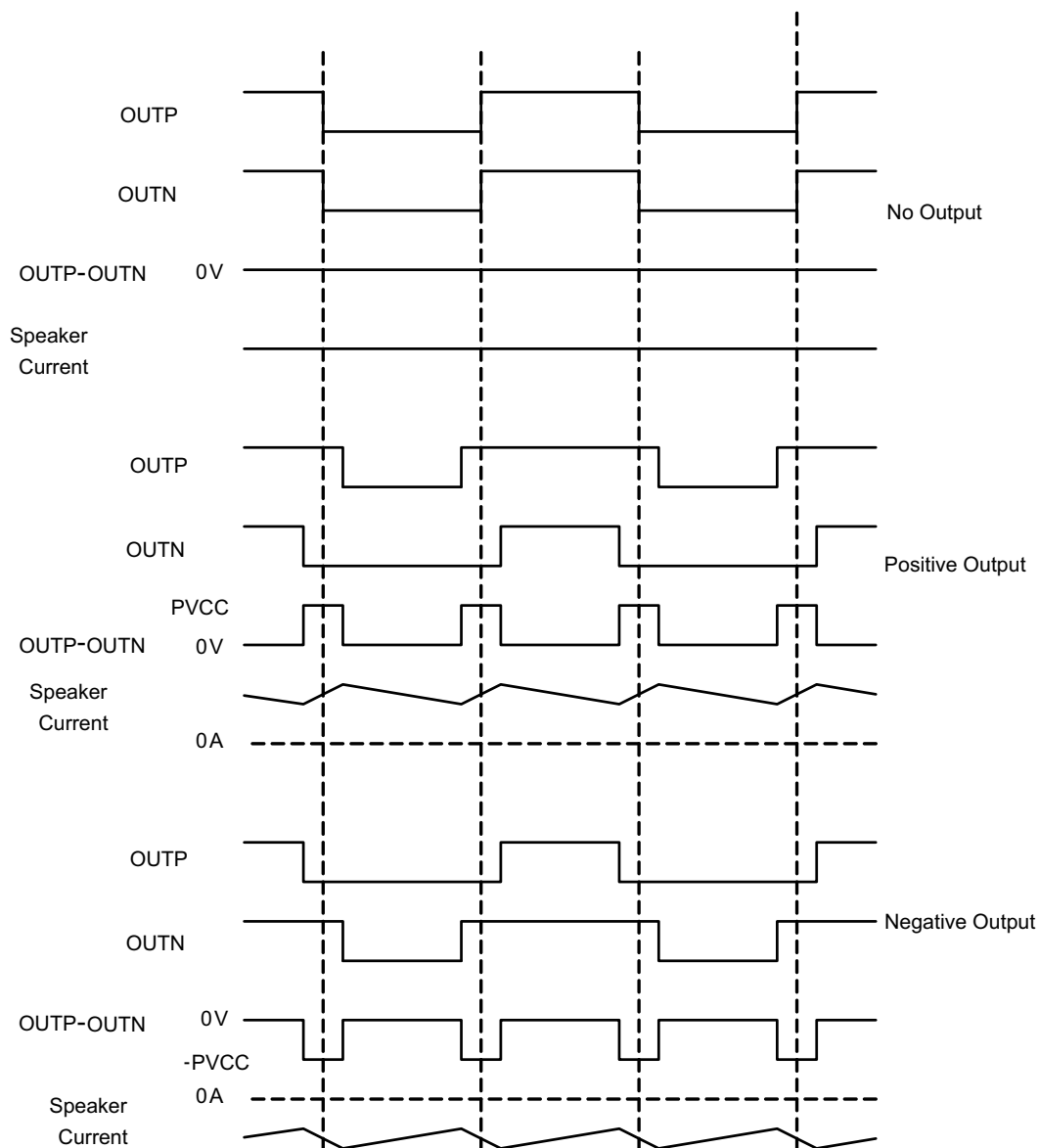

Figure 17. BD Mode Modulation

10 Application and Implementation

NOTE

Information in the following applications sections is not part of the TI component specification, and TI does not warrant its accuracy or completeness. TI's customers are responsible for determining suitability of components for their purposes. Customers should validate and test their design implementation to confirm system functionality.

10.1 Application Information

The TPA3137D2 device is designed for use in inductor free applications with limited distance wire length) between amplifier and speakers like in TV sets, sound docks and Bluetooth speakers. The TPA3137D2 device can either be configured in stereo or mono mode, depending on output power conditions. Depending on output power requirements and necessity for (speaker) load protection, the built in PLIMIT circuit can be used to control system power, see functional description of these features.

10.2 Typical Applications

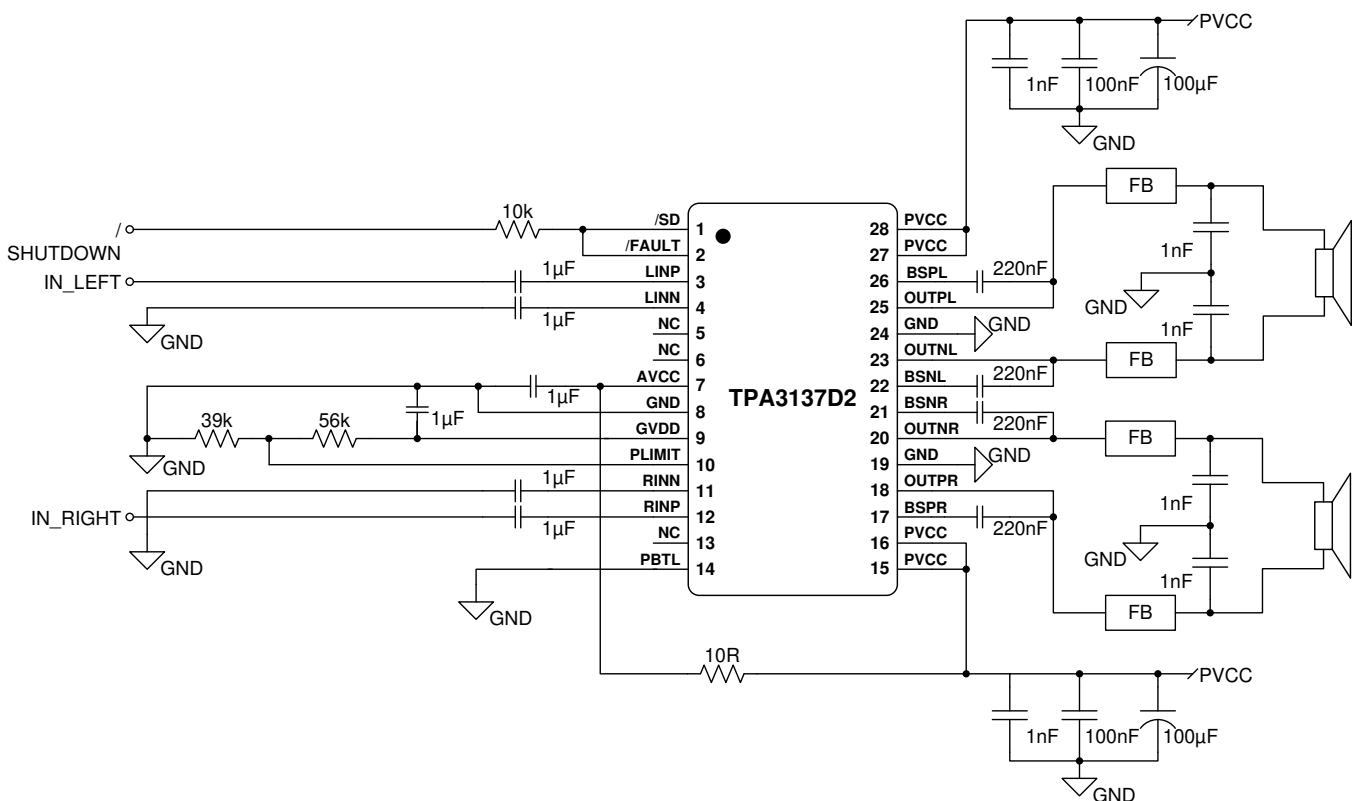

Figure 18. Stereo Class-D Amplifier with BTL Output and Single-Ended Inputs with Spread Spectrum Modulation

Typical Applications (continued)

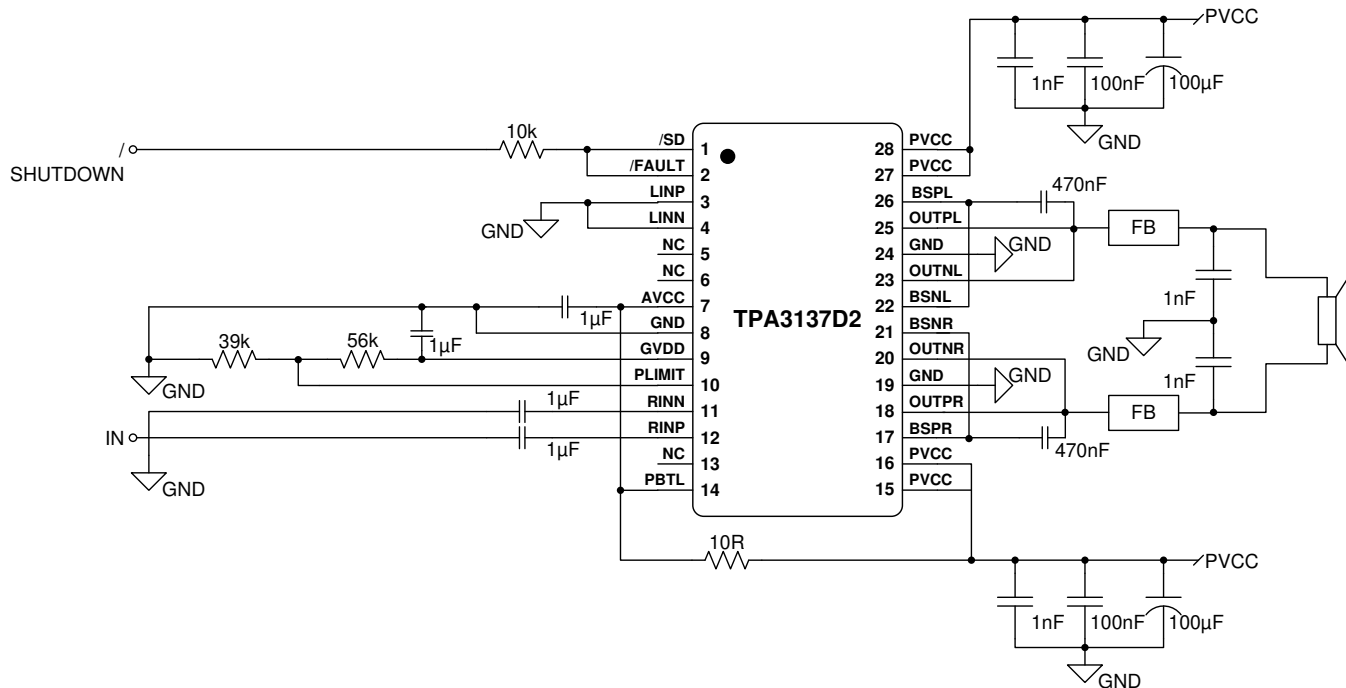

Figure 19. Stereo Class-D Amplifier with PBTl Output and Single-Ended Input with Spread Spectrum Modulation

10.2.1 Design Requirements

10.2.1.1 PCB Material Recommendation

FR-4 Glass Epoxy material with 1 oz. (35 µm) is recommended for use with the TPA3137D2. The use of this material can provide for higher power output, improved thermal performance, and better EMI margin (due to lower PCB trace inductance). It is recommended to use several GND underneath the device thermal pad for thermal coupling to a bottom side copper GND plane for best thermal performance.

10.2.1.2 PVCC Capacitor Recommendation

The large capacitors used in conjunction with each full-bridge, are referred to as the PVCC Capacitors. These capacitors should be selected for proper voltage margin and adequate capacitance to support the power requirements. In practice, with a well designed system power supply, 100 µF, 16 V will support most applications with 12-V power supply. 25-V capacitor rating is recommended for power supply voltage higher than 12 V. For The PVCC capacitors should be low ESR type because they are used in a circuit associated with high-speed switching.

10.2.1.3 Decoupling Capacitor Recommendations

In order to design an amplifier that has robust performance, passes regulatory requirements, and exhibits good audio performance, good quality decoupling capacitors should be used. In practice, X7R should be used in this application.

The voltage of the decoupling capacitors should be selected in accordance with good design practices. Temperature, ripple current, and voltage overshoot must be considered. This fact is particularly true in the selection of the ceramic capacitors that are placed on the power supply to each full-bridge. They must withstand the voltage overshoot of the PWM switching, the heat generated by the amplifier during high power output, and the ripple current created by high power output. A minimum voltage rating of 16 V is required for use with a 12-V power supply.

Typical Applications (continued)

10.2.2 Detailed Design Procedure

A rising-edge transition on \overline{SD} input allows the device to start switching. It is recommended to ramp the PVCC voltage to its desired value before releasing \overline{SD} for minimum audible artifacts.

The device is non-inverting the audio signal from input to output.

The GVDD pin is not recommended to be used as a voltage source for external circuitry.

10.2.2.1 Ferrite Bead Filter Considerations

Using the Advanced Emissions Suppression Technology in the TPA3137D2 amplifier it is possible to design a high efficiency Class-D audio amplifier while minimizing interference to surrounding circuits. It is also possible to accomplish this with only a low-cost ferrite bead filter. In this case it is necessary to carefully select the ferrite bead used in the filter.

One important aspect of the ferrite bead selection is the type of material used in the ferrite bead. Not all ferrite material is alike, so it is important to select a material that is effective in the 10 to 100 MHz range which is key to the operation of the Class-D amplifier. Many of the specifications regulating consumer electronics have emissions limits as low as 30 MHz. It is important to use the ferrite bead filter to block radiation in the 30-MHz and above range from appearing on the speaker wires and the power supply lines which are good antennas for these signals. The impedance of the ferrite bead can be used along with a small capacitor with a value in the range of 1000 pF to reduce the frequency spectrum of the signal to an acceptable level. For best performance, the resonant frequency of the ferrite bead/ capacitor filter should be less than 10 MHz.

Also, it is important that the ferrite bead is large enough to maintain its impedance at the peak currents expected for the amplifier. Some ferrite bead manufacturers specify the bead impedance at a variety of current levels. In this case it is possible to make sure the ferrite bead maintains an adequate amount of impedance at the peak current the amplifier will see. If these specifications are not available, it is also possible to estimate the bead's current handling capability by measuring the resonant frequency of the filter output at low power and at maximum power. A change of resonant frequency of less than fifty percent under this condition is desirable. Examples of ferrite beads which have been tested and work well with the TPA3137D2 device include NFZ2MSM series from Murata.

A high quality ceramic capacitor is also needed for the ferrite bead filter. A low ESR capacitor with good temperature and voltage characteristics will work best.

Additional EMC improvements may be obtained by adding snubber networks from each of the class-D outputs to ground. Suggested values for a simple RC series snubber network would be 68 Ω in series with a 100-pF capacitor although design of the snubber network is specific to every application and must be designed taking into account the parasitic reactance of the printed circuit board as well as the audio amp. Take care to evaluate the stress on the component in the snubber network especially if the amp is running at high PVCC. Also, make sure the layout of the snubber network is tight and returns directly to the GND or the thermal pad beneath the chip.

10.2.2.2 Efficiency: LC Filter Required with the Traditional Class-D Modulation Scheme

The main reason that the traditional class-D amplifier needs an output filter is that the switching waveform results in maximum current flow. This causes more loss in the load, which causes lower efficiency. The ripple current is large for the traditional modulation scheme, because the ripple current is proportional to voltage multiplied by the time at that voltage. The differential voltage swing is $2 \times V_{CC}$, and the time at each voltage is half the period for the traditional modulation scheme. An ideal LC filter is needed to store the ripple current from each half cycle for the next half cycle, while any resistance causes power dissipation. The speaker is both resistive and reactive, whereas an LC filter is almost purely reactive.

The TPA3137D2 modulation scheme has little loss in the load without a filter because the pulses are short and the change in voltage is V_{CC} instead of $2 \times V_{CC}$. As the output power increases, the pulses widen, making the ripple current larger. Ripple current could be filtered with an LC filter for increased efficiency, but for most applications the filter is not needed.

An LC filter with a cutoff frequency less than the class-D switching frequency allows the switching current to flow through the filter instead of the load. The filter has less resistance but higher impedance at the switching frequency than the speaker, which results in less power dissipation, therefore increasing efficiency.

Typical Applications (continued)

10.2.2.3 When to Use an Output Filter for EMI Suppression

The TPA3137D2 device has been tested with a simple ferrite bead filter for a variety of applications including long speaker wires up to 100 cm and high power. The TPA3137D2 EVM passes FCC Class B specifications under these conditions using twisted speaker wires. The size and type of ferrite bead can be selected to meet application requirements. Also, the filter capacitor can be increased if necessary with some impact on efficiency.

There may be a few circuit instances where it is necessary to add a complete LC reconstruction filter. These circumstances might occur if there are nearby circuits which are sensitive to noise. In these cases, a classic second order Butterworth filter similar to those shown in the following figures can be used.

Some systems have little power supply decoupling from the AC line, but are also subject to line conducted interference (LCI) regulations. These include systems powered by "wall warts" and "power bricks." In these cases, LC reconstruction filters can be the lowest cost means to pass LCI tests. Common mode chokes using low frequency ferrite material can also be effective at preventing line conducted interference.

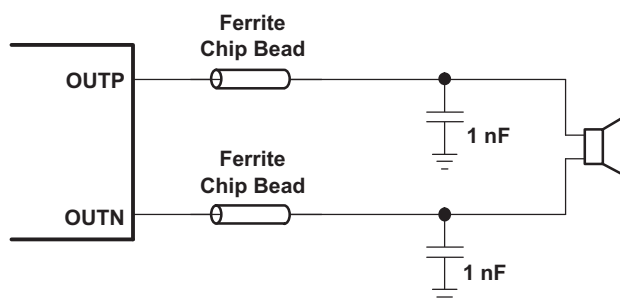

Figure 20. Typical Ferrite Chip Bead Filter (Chip Bead Example: NFZ2MSM series from Murata)

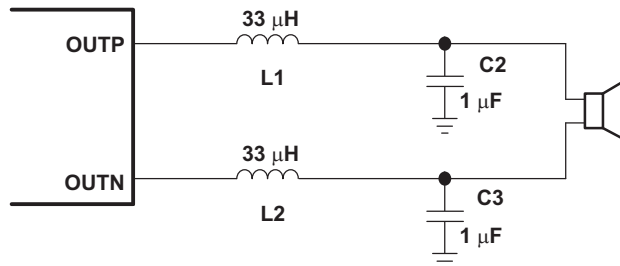

Figure 21. Typical LC Output Filter, Cutoff Frequency of 27 kHz, Speaker Impedance = 8 Ω

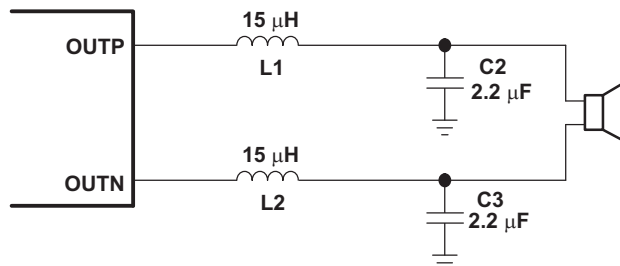
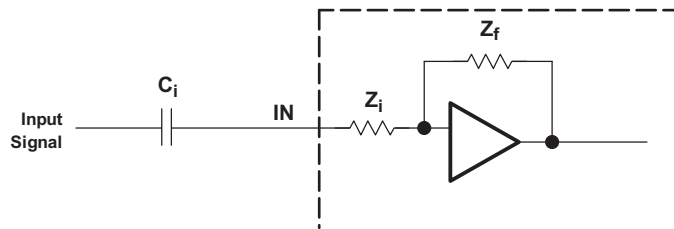

Figure 22. Typical LC Output Filter, Cutoff Frequency of 27 kHz, Speaker Impedance = 6 Ω

10.2.2.4 Input Resistance

The typical input resistance of the amplifier is fixed to 30 kΩ ±20%.

Typical Applications (continued)



10.2.2.5 Input Capacitor, C_i

In the typical application, an input capacitor (C_i) is required to allow the amplifier to bias the input signal to the proper dc level for optimum operation. In this case, C_i and the input impedance of the amplifier (Z_i) form a high-pass filter with the corner frequency determined in [Equation 2](#).

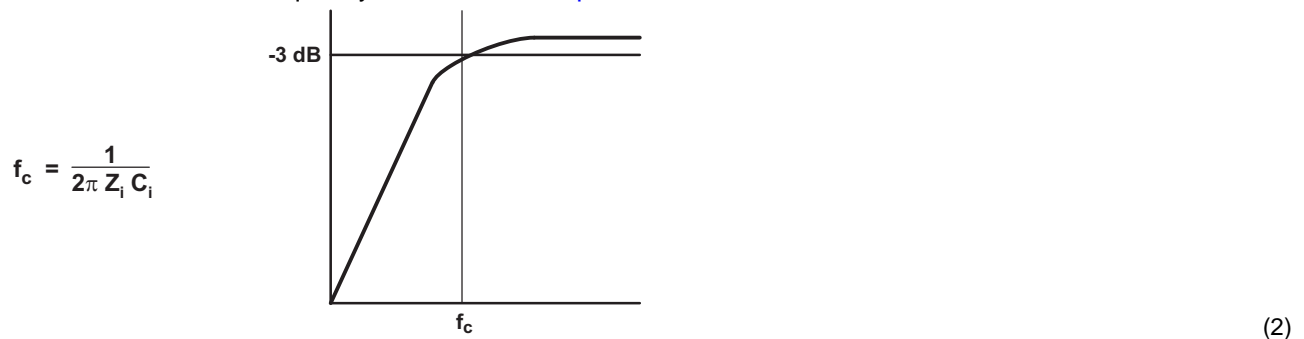

The value of C_i is important, as it directly affects the bass (low-frequency) performance of the circuit. Consider the example where Z_i is 30 k Ω and the specification calls for a flat bass response down to 20 Hz. [Equation 2](#) is reconfigured as [Equation 3](#).

$$C_i = \frac{1}{2\pi Z_i f_c} \quad (3)$$

In this example, C_i is 0.27 μF ; so, one would likely choose a value of 0.33 μF as this value is commonly used. A further consideration for this capacitor is the leakage path from the input source through the input network (C_i) and the feedback network to the load. This leakage current creates a dc offset voltage at the input to the amplifier that reduces useful headroom. For this reason, a low-leakage tantalum or ceramic capacitor is the best choice. When polarized capacitors are used, the positive side of the capacitor should face the amplifier input in most applications as the dc level there is held at 3 V, which is likely higher than the source dc level. Note that it is important to confirm the capacitor polarity in the application. Additionally, lead-free solder can create dc offset voltages and it is important to ensure that boards are cleaned properly.

10.2.2.6 BSN and BSP Capacitors

The full H-bridge output stages use only NMOS transistors. Therefore, they require bootstrap capacitors for the high side of each output to turn on correctly. A 0.22- μF ceramic capacitor, rated for at least 25 V, must be connected from each output to its corresponding bootstrap input. Specifically, one 0.22- μF capacitor must be connected from OUPx to BSPx, and one 0.22- μF capacitor must be connected from OUTNx to BSNx. (See the application circuit diagram in [Figure 18](#).)

The bootstrap capacitors connected between the BSxx pins and corresponding output function as a floating power supply for the high-side N-channel power MOSFET gate drive circuitry. During each high-side switching cycle, the bootstrap capacitors hold the gate-to-source voltage high enough to keep the high-side MOSFETs turned on.

Typical Applications (continued)

10.2.2.7 Differential Inputs

The differential input stage of the amplifier cancels any noise that appears on both input lines of the channel. To use the TPA3137D2 device with a differential source, connect the positive lead of the audio source to the INP input and the negative lead from the audio source to the INN input. To use the TPA3137D2 with a single-ended source, ac ground the INP or INN input through a capacitor equal in value to the input capacitor on INN or INP and apply the audio source to either input. In a single-ended input application, the unused input should be ac grounded at the audio source instead of at the device input for best noise performance. For good transient performance, the impedance seen at each of the two differential inputs should be the same.

The impedance seen at the inputs should be limited to an RC time constant of 1 ms or less if possible. This is to allow the input dc blocking capacitors to become completely charged during the 14-ms power-up time. If the input capacitors are not allowed to completely charge, there is some additional sensitivity to component matching which can result in pop if the input components are not well matched.

10.2.2.8 Using Low-ESR Capacitors

Low-ESR capacitors are recommended throughout this application section. A real (as opposed to ideal) capacitor can be modeled simply as a resistor in series with an ideal capacitor. The voltage drop across this resistor minimizes the beneficial effects of the capacitor in the circuit. The lower the equivalent value of this resistance, the more the real capacitor behaves like an ideal capacitor.

Typical Applications (continued)

10.2.3 Application Performance Curves

10.2.3.1 EN55013 Radiated Emissions Results

TPA3137D2 EVM, PVCC = 12 V, 8-Ω speakers, P_O = 4 W

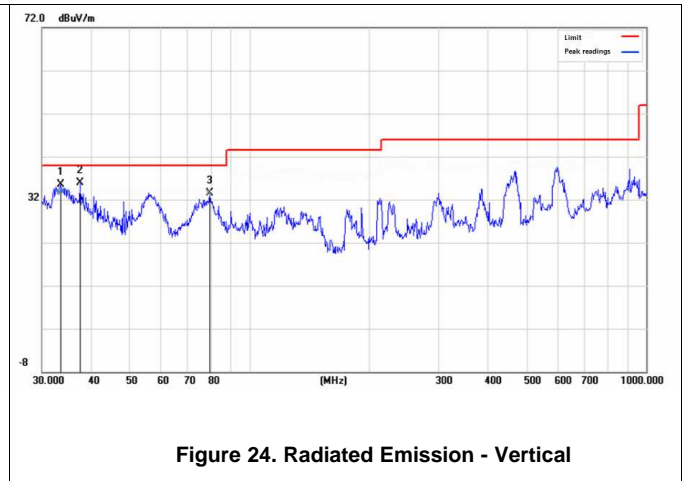
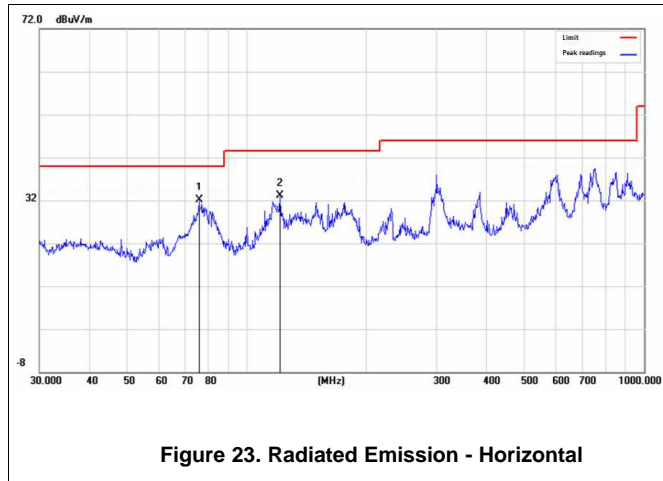

10.2.3.2 EN55022 Conducted Emissions Results

TPA3137D2 EVM, PVCC = 12 V, 8-Ω speakers, P_O = 4 W

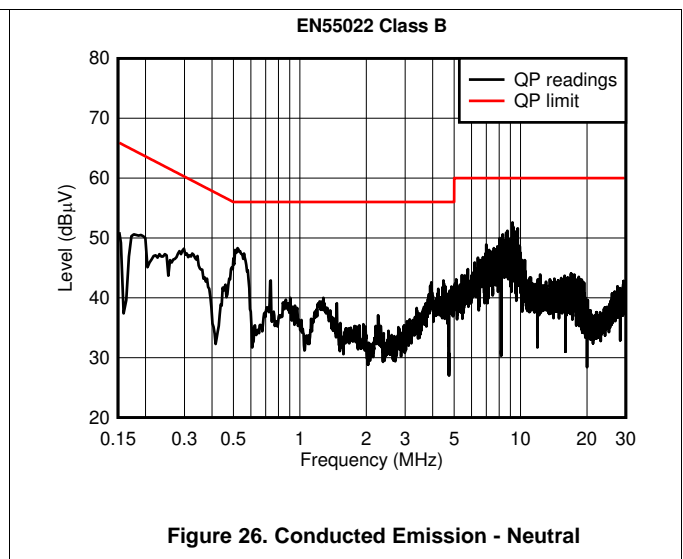
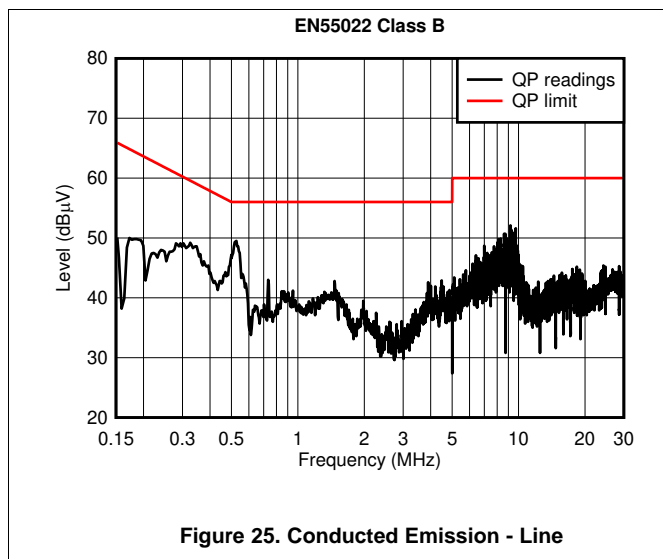

11 Power Supply Recommendations

11.1 Power Supply Decoupling, C_s

The TPA3137D2 device is a high-performance CMOS audio amplifier that requires adequate power supply decoupling to ensure that the output total harmonic distortion (THD) is as low as possible. Power supply decoupling also prevents oscillations for long lead lengths between the amplifier and the speaker. Optimum decoupling is achieved by using a network of capacitors of different types that target specific types of noise on the power supply leads. For higher frequency transients due to parasitic circuit elements such as bond wire and copper trace inductances as well as lead frame capacitance, a good quality low equivalent-series-resistance (ESR) ceramic capacitor of value between 220 pF and 1000 pF works well. This capacitor should be placed as close to the device PVCC pins and system ground (either GND pins or thermal pad) as possible. For mid-frequency noise due to filter resonances or PWM switching transients as well as digital hash on the line, another good quality capacitor typically 0.1 μ F to 1 μ F placed as close as possible to the device PVCC leads works best. For filtering lower frequency noise signals, a larger aluminum electrolytic capacitor of 100 μ F or greater placed near the audio power amplifier is recommended. The 100- μ F capacitor also serves as a local storage capacitor for supplying current during large signal transients on the amplifier outputs. The PVCC pins provide the power to the output transistors, so a 100- μ F or larger capacitor should be placed on each PVCC pin. A 1- μ F capacitor on the AVCC pin is adequate. Also, a small decoupling resistor between AVCC and PVCC can be used to keep high frequency class-D noise from entering the linear input amplifiers.

12 Layout

12.1 Layout Guidelines

The TPA3137D2 device can be used with a small, inexpensive ferrite bead output filter for most applications. However, since the Class-D switching edges are fast, it is necessary to take care when planning the layout of the printed circuit board. The following suggestions will help to meet EMC requirements.

- Decoupling capacitors—The high-frequency decoupling capacitors should be placed as close to the PVCC and AVCC pins as possible. Large (100- μ F or greater) bulk power supply decoupling capacitors should be placed near the TPA3137D2 device on the PVCC supplies. Local, high-frequency bypass capacitors should be placed as close to the PVCC pins as possible. These caps can be connected to the thermal pad directly for an excellent ground connection. Consider adding a small, good quality low ESR ceramic capacitor between 220 pF and 1000 pF and a larger mid-frequency cap of value between 0.1 μ F and 1 μ F also of good quality to the PVCC connections at each end of the chip.
- Keep the current loop from each of the outputs through the ferrite bead and the small filter cap and back to GND as small and tight as possible. The size of this current loop determines its effectiveness as an antenna.
- Grounding—The AVCC (pin 14) decoupling capacitor should be connected to ground (GND). The PVCC decoupling capacitors should connect to GND. Analog ground and power ground should be connected at the thermal pad, which should be used as a central ground connection or star ground for the TPA3137D2.
- Output filter—The ferrite EMI filter ([Figure 20](#)) should be placed as close to the output pins as possible for the best EMI performance. The capacitors used in the ferrite should be grounded to power ground.
- Thermal Pad—The thermal pad must be soldered to the PCB for proper thermal performance and optimal reliability. The dimensions of the thermal pad and thermal land should be 6.46 mm \times 2.35 mm. Six rows of solid vias (three vias per row, 0.3302 mm or 13 mils diameter) should be equally spaced underneath the thermal land. The vias should connect to a solid copper plane, either on an internal layer or on the bottom layer of the PCB. The vias must be solid vias, not thermal relief or webbed vias. See the TI Application Report [SLMA002](#) for more information about using the TSSOP thermal pad. For recommended PCB footprints, see figures at the end of this data sheet.

For an example layout, see the TPA3137D2 Evaluation Module (TPA3137D2EVM) User Manual. Both the EVM user manual and the thermal pad application report are available on the TI Web site at <http://www.ti.com>.

12.2 Layout Example

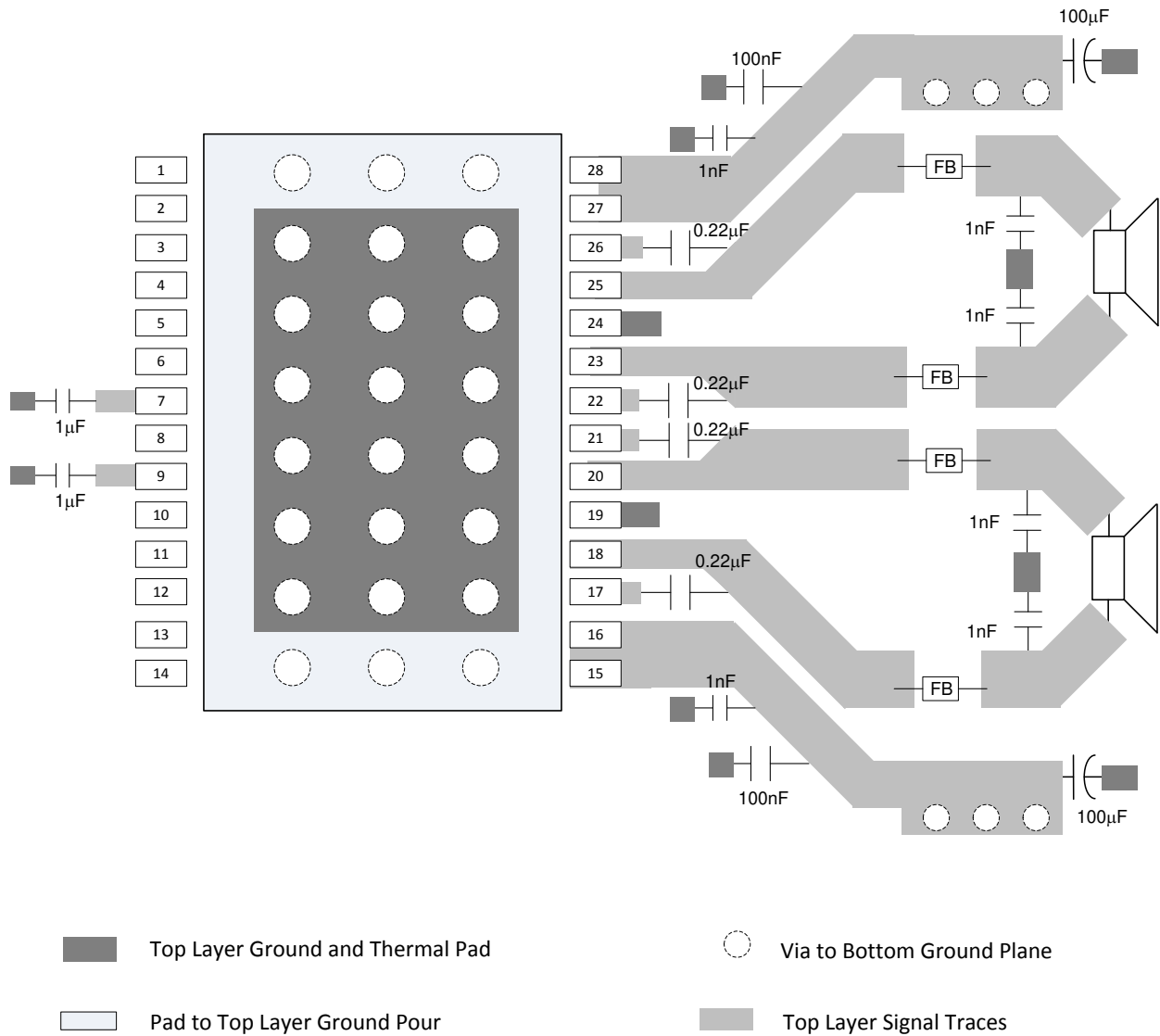

Figure 27. BTL Layout Example

13 Device and Documentation Support

13.1 Device Support

13.1.1 Third-Party Products Disclaimer

TI'S PUBLICATION OF INFORMATION REGARDING THIRD-PARTY PRODUCTS OR SERVICES DOES NOT CONSTITUTE AN ENDORSEMENT REGARDING THE SUITABILITY OF SUCH PRODUCTS OR SERVICES OR A WARRANTY, REPRESENTATION OR ENDORSEMENT OF SUCH PRODUCTS OR SERVICES, EITHER ALONE OR IN COMBINATION WITH ANY TI PRODUCT OR SERVICE.

13.2 Documentation Support

13.2.1 Related Documentation

PowerPAD™ Thermally Enhanced Package Application Report (SLMA002)

13.3 Related Links

The table below lists quick access links. Categories include technical documents, support and community resources, tools and software, and quick access to order now.

13.4 Receiving Notification of Documentation Updates

To receive notification of documentation updates, navigate to the device product folder on ti.com. In the upper right corner, click on *Alert me* to register and receive a weekly digest of any product information that has changed. For change details, review the revision history included in any revised document.

13.5 Support Resources

[TI E2E™ support forums](#) are an engineer's go-to source for fast, verified answers and design help — straight from the experts. Search existing answers or ask your own question to get the quick design help you need.

Linked content is provided "AS IS" by the respective contributors. They do not constitute TI specifications and do not necessarily reflect TI's views; see TI's [Terms of Use](#).

13.6 Trademarks

SpeakerGuard, E2E are trademarks of Texas Instruments. All other trademarks are the property of their respective owners.

13.7 Electrostatic Discharge Caution



These devices have limited built-in ESD protection. The leads should be shorted together or the device placed in conductive foam during storage or handling to prevent electrostatic damage to the MOS gates.

13.8 Glossary

[SLYZ022](#) — *TI Glossary*.

This glossary lists and explains terms, acronyms, and definitions.

14 Mechanical, Packaging, and Orderable Information

The following pages include mechanical, packaging, and orderable information. This information is the most current data available for the designated devices. This data is subject to change without notice and revision of this document. For browser-based versions of this data sheet, refer to the left-hand navigation.

PACKAGING INFORMATION

Orderable part number	Status (1)	Material type (2)	Package Pins	Package qty Carrier	RoHS (3)	Lead finish/ Ball material (4)	MSL rating/ Peak reflow (5)	Op temp (°C)	Part marking (6)
TPA3137D2PWP	Active	Production	HTSSOP (PWP) 28	50 TUBE	Yes	NIPDAU	Level-3-260C-168 HR	-40 to 85	TPA3137D2
TPA3137D2PWP.A	Active	Production	HTSSOP (PWP) 28	50 TUBE	Yes	NIPDAU	Level-3-260C-168 HR	-40 to 85	TPA3137D2
TPA3137D2PWP.B	Active	Production	HTSSOP (PWP) 28	50 TUBE	Yes	NIPDAU	Level-3-260C-168 HR	-40 to 85	TPA3137D2
TPA3137D2PWPR	Active	Production	HTSSOP (PWP) 28	2000 LARGE T&R	Yes	NIPDAU	Level-3-260C-168 HR	-40 to 85	TPA3137D2
TPA3137D2PWPR.A	Active	Production	HTSSOP (PWP) 28	2000 LARGE T&R	Yes	NIPDAU	Level-3-260C-168 HR	-40 to 85	TPA3137D2
TPA3137D2PWPR.B	Active	Production	HTSSOP (PWP) 28	2000 LARGE T&R	Yes	NIPDAU	Level-3-260C-168 HR	-40 to 85	TPA3137D2

(1) **Status:** For more details on status, see our [product life cycle](#).

(2) **Material type:** When designated, preproduction parts are prototypes/experimental devices, and are not yet approved or released for full production. Testing and final process, including without limitation quality assurance, reliability performance testing, and/or process qualification, may not yet be complete, and this item is subject to further changes or possible discontinuation. If available for ordering, purchases will be subject to an additional waiver at checkout, and are intended for early internal evaluation purposes only. These items are sold without warranties of any kind.

(3) **RoHS values:** Yes, No, RoHS Exempt. See the [TI RoHS Statement](#) for additional information and value definition.

(4) **Lead finish/Ball material:** Parts may have multiple material finish options. Finish options are separated by a vertical ruled line. Lead finish/Ball material values may wrap to two lines if the finish value exceeds the maximum column width.

(5) **MSL rating/Peak reflow:** The moisture sensitivity level ratings and peak solder (reflow) temperatures. In the event that a part has multiple moisture sensitivity ratings, only the lowest level per JEDEC standards is shown. Refer to the shipping label for the actual reflow temperature that will be used to mount the part to the printed circuit board.

(6) **Part marking:** There may be an additional marking, which relates to the logo, the lot trace code information, or the environmental category of the part.

Multiple part markings will be inside parentheses. Only one part marking contained in parentheses and separated by a "~" will appear on a part. If a line is indented then it is a continuation of the previous line and the two combined represent the entire part marking for that device.

Important Information and Disclaimer: The information provided on this page represents TI's knowledge and belief as of the date that it is provided. TI bases its knowledge and belief on information provided by third parties, and makes no representation or warranty as to the accuracy of such information. Efforts are underway to better integrate information from third parties. TI has taken and continues to take reasonable steps to provide representative and accurate information but may not have conducted destructive testing or chemical analysis on incoming materials and chemicals. TI and TI suppliers consider certain information to be proprietary, and thus CAS numbers and other limited information may not be available for release.

In no event shall TI's liability arising out of such information exceed the total purchase price of the TI part(s) at issue in this document sold by TI to Customer on an annual basis.

TAPE AND REEL INFORMATION

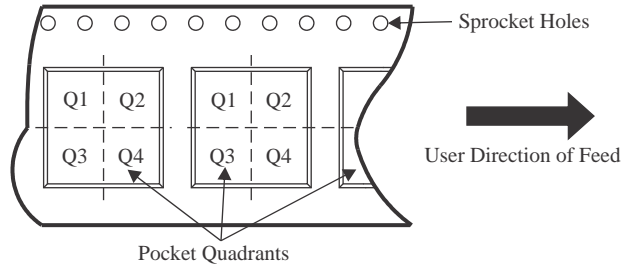
QUADRANT ASSIGNMENTS FOR PIN 1 ORIENTATION IN TAPE

*All dimensions are nominal

Device	Package Type	Package Drawing	Pins	SPQ	Reel Diameter (mm)	Reel Width W1 (mm)	A0 (mm)	B0 (mm)	K0 (mm)	P1 (mm)	W (mm)	Pin1 Quadrant
TPA3137D2PWPR	HTSSOP	PWP	28	2000	330.0	16.4	6.9	10.2	1.8	12.0	16.0	Q1

TAPE AND REEL BOX DIMENSIONS

*All dimensions are nominal

Device	Package Type	Package Drawing	Pins	SPQ	Length (mm)	Width (mm)	Height (mm)
TPA3137D2PWPR	HTSSOP	PWP	28	2000	350.0	350.0	43.0

TUBE

*All dimensions are nominal

Device	Package Name	Package Type	Pins	SPQ	L (mm)	W (mm)	T (μm)	B (mm)
TPA3137D2PWP	PWP	HTSSOP	28	50	530	10.2	3600	3.5
TPA3137D2PWP.A	PWP	HTSSOP	28	50	530	10.2	3600	3.5
TPA3137D2PWP.B	PWP	HTSSOP	28	50	530	10.2	3600	3.5

GENERIC PACKAGE VIEW

PWP 28

PowerPAD™ TSSOP - 1.2 mm max height

4.4 x 9.7, 0.65 mm pitch

SMALL OUTLINE PACKAGE

This image is a representation of the package family, actual package may vary.
Refer to the product data sheet for package details.

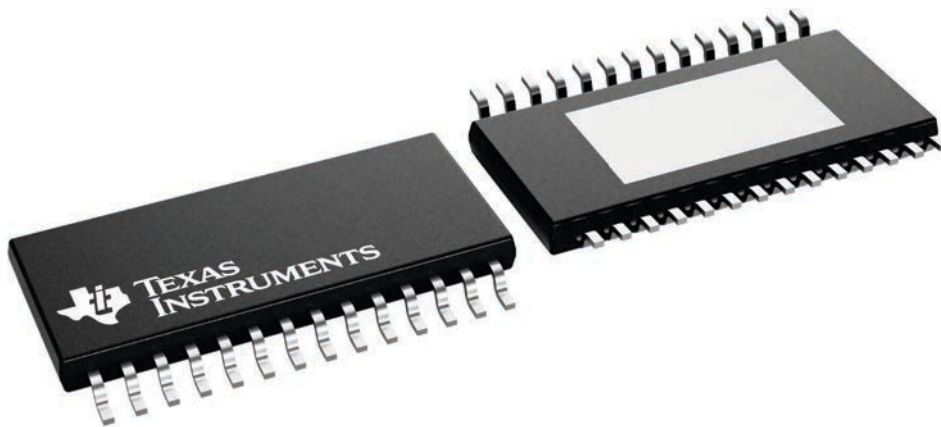

4224765/B

MECHANICAL DATA

PWP (R-PDSO-G28)

PowerPAD™ PLASTIC SMALL OUTLINE

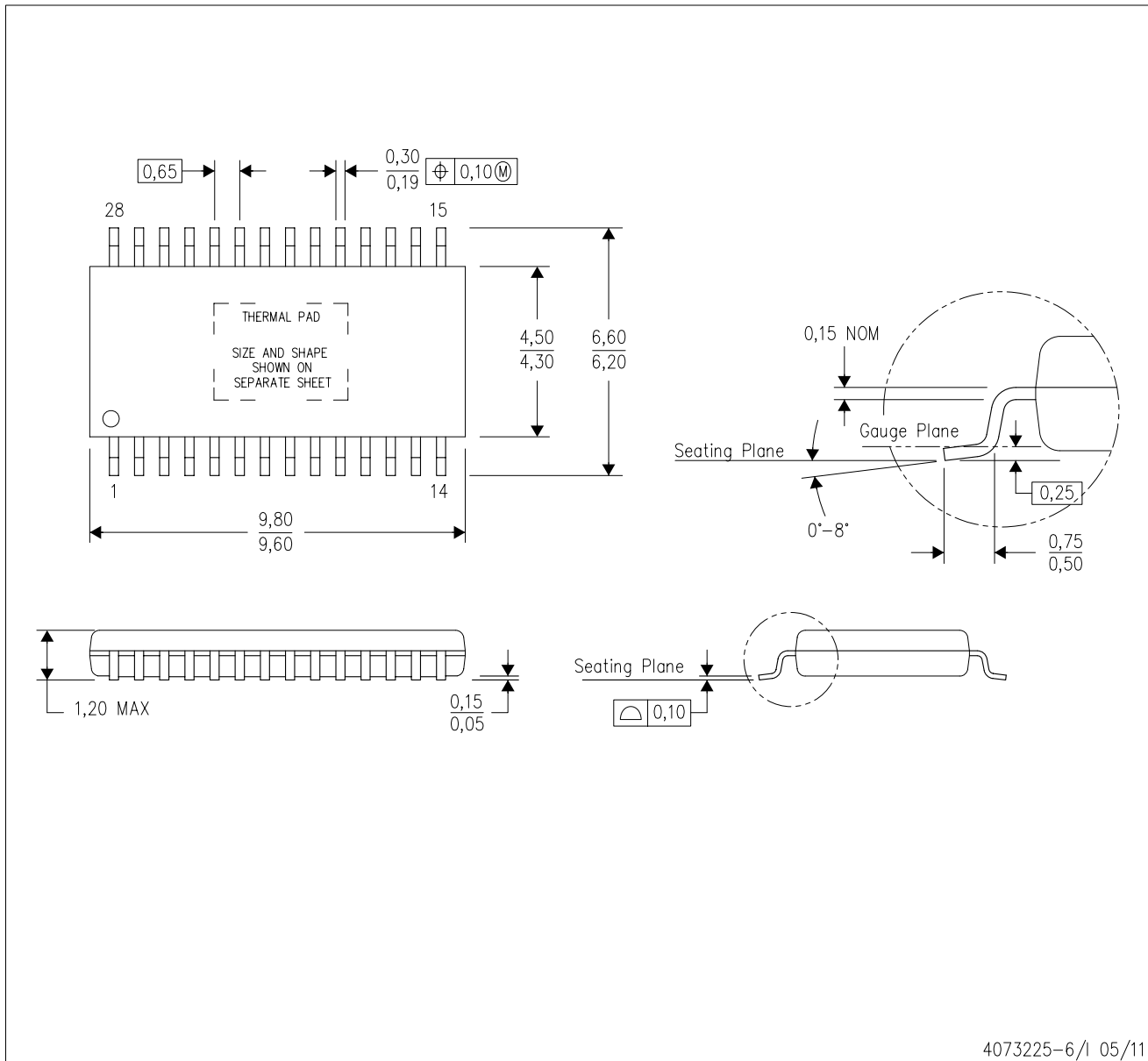

- NOTES:
- All linear dimensions are in millimeters.
 - This drawing is subject to change without notice.
 - Body dimensions do not include mold flash or protrusions. Mold flash and protrusion shall not exceed 0.15 per side.
 - This package is designed to be soldered to a thermal pad on the board. Refer to Technical Brief, PowerPad Thermally Enhanced Package, Texas Instruments Literature No. SLMA002 for information regarding recommended board layout. This document is available at www.ti.com <<http://www.ti.com>>.
 - See the additional figure in the Product Data Sheet for details regarding the exposed thermal pad features and dimensions.
 - Falls within JEDEC MO-153

PowerPAD is a trademark of Texas Instruments.

THERMAL PAD MECHANICAL DATA

PWP (R-PDSO-G28) PowerPAD™ SMALL PLASTIC OUTLINE

THERMAL INFORMATION

This PowerPAD™ package incorporates an exposed thermal pad that is designed to be attached to a printed circuit board (PCB). The thermal pad must be soldered directly to the PCB. After soldering, the PCB can be used as a heatsink. In addition, through the use of thermal vias, the thermal pad can be attached directly to the appropriate copper plane shown in the electrical schematic for the device, or alternatively, can be attached to a special heatsink structure designed into the PCB. This design optimizes the heat transfer from the integrated circuit (IC).

For additional information on the PowerPAD package and how to take advantage of its heat dissipating abilities, refer to Technical Brief, PowerPAD Thermally Enhanced Package, Texas Instruments Literature No. SLMA002 and Application Brief, PowerPAD Made Easy, Texas Instruments Literature No. SLMA004. Both documents are available at www.ti.com.

The exposed thermal pad dimensions for this package are shown in the following illustration.

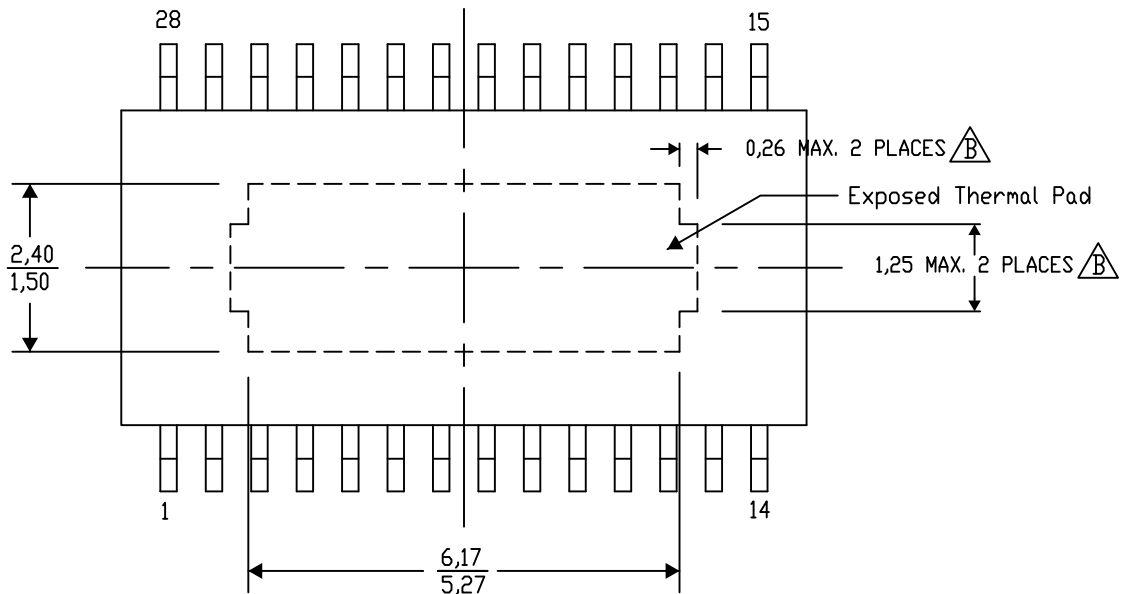

Top View

Exposed Thermal Pad Dimensions

4206332-33/AO 01/16

NOTE: A. All linear dimensions are in millimeters
B. Exposed tie strap features may not be present.

PowerPAD is a trademark of Texas Instruments

PWP (R-PDSO-G28)

PowerPAD™ PLASTIC SMALL OUTLINE

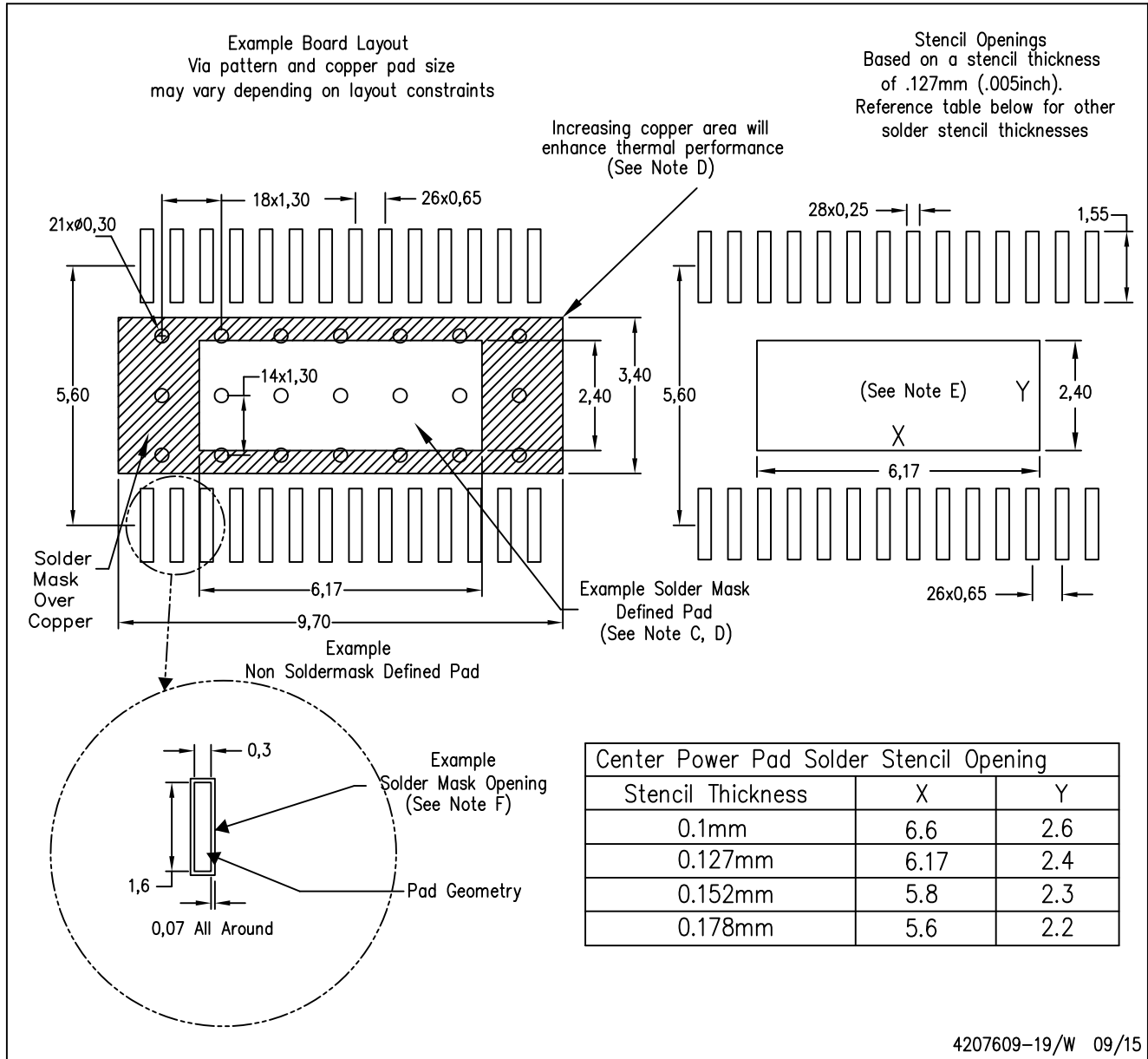

- NOTES:
- A. All linear dimensions are in millimeters.
 - B. This drawing is subject to change without notice.
 - C. Customers should place a note on the circuit board fabrication drawing not to alter the center solder mask defined pad.
 - D. This package is designed to be soldered to a thermal pad on the board. Refer to Technical Brief, PowerPad Thermally Enhanced Package, Texas Instruments Literature No. SLMA002, SLMA004, and also the Product Data Sheets.
 - E. For specific thermal information, via requirements, and recommended board layout. These documents are available at www.ti.com <<http://www.ti.com>>. Publication IPC-7351 is recommended for alternate designs. Laser cutting apertures with trapezoidal walls and also rounding corners will offer better paste release. Customers should contact their board assembly site for stencil design recommendations. Example stencil design based on a 50% volumetric metal load solder paste. Refer to IPC-7525 for other stencil
 - F. Customers should contact their board fabrication site for solder mask tolerances between and around signal pads.

IMPORTANT NOTICE AND DISCLAIMER

TI PROVIDES TECHNICAL AND RELIABILITY DATA (INCLUDING DATASHEETS), DESIGN RESOURCES (INCLUDING REFERENCE DESIGNS), APPLICATION OR OTHER DESIGN ADVICE, WEB TOOLS, SAFETY INFORMATION, AND OTHER RESOURCES "AS IS" AND WITH ALL FAULTS, AND DISCLAIMS ALL WARRANTIES, EXPRESS AND IMPLIED, INCLUDING WITHOUT LIMITATION ANY IMPLIED WARRANTIES OF MERCHANTABILITY, FITNESS FOR A PARTICULAR PURPOSE OR NON-INFRINGEMENT OF THIRD PARTY INTELLECTUAL PROPERTY RIGHTS.

These resources are intended for skilled developers designing with TI products. You are solely responsible for (1) selecting the appropriate TI products for your application, (2) designing, validating and testing your application, and (3) ensuring your application meets applicable standards, and any other safety, security, regulatory or other requirements.

These resources are subject to change without notice. TI grants you permission to use these resources only for development of an application that uses the TI products described in the resource. Other reproduction and display of these resources is prohibited. No license is granted to any other TI intellectual property right or to any third party intellectual property right. TI disclaims responsibility for, and you fully indemnify TI and its representatives against any claims, damages, costs, losses, and liabilities arising out of your use of these resources.

TI's products are provided subject to [TI's Terms of Sale](#), [TI's General Quality Guidelines](#), or other applicable terms available either on ti.com or provided in conjunction with such TI products. TI's provision of these resources does not expand or otherwise alter TI's applicable warranties or warranty disclaimers for TI products. Unless TI explicitly designates a product as custom or customer-specified, TI products are standard, catalog, general purpose devices.

TI objects to and rejects any additional or different terms you may propose.

Copyright © 2025, Texas Instruments Incorporated

Last updated 10/2025

Looking for pricing, stock, or lifecycle information?

Click below to explore more details on WIN SOURCE:

 [View TPA3137D2PWP](#) on WIN SOURCE

 [Texas Instruments](#) Information

Optimize Your Supply Chain with WIN SOURCE Solutions

-  Global Sourcing Solution
-  Obsolete Management
-  Cost Control Management
-  Shortage Management
-  Alternative Solution
-  Excess Inventory Management