



# ISO6731 General-Purpose Triple-Channel Digital Isolator with Robust EMC

## 1 Features

- 50 Mbps data rate
- Robust isolation barrier:
  - High lifetime at 1500 V<sub>RMS</sub> working voltage
  - Up to 5000 V<sub>RMS</sub> isolation rating
  - Up to 10 kV surge capability
  - ±150 kV/μs typical CMTI
- Wide supply range: 1.71 V to 1.89 V and 2.25 V to 5.5 V
- 1.71 V to 5.5 V level translation
- Default output *high* (ISO6731) and *low* (ISO6731F) options
- Wide temperature range: –40°C to 125°C
- 1.6 mA per channel typical at 1 Mbps
- Low propagation delay: 11 ns typical
- Robust electromagnetic compatibility (EMC)
  - System-level ESD, EFT, and surge immunity
  - ±8 kV IEC 61000-4-2 contact discharge protection across isolation barrier
  - Low emissions
- Wide-SOIC (DW-16) Package
- [Safety-Related Certifications](#):
  - DIN EN IEC 60747-17 (VDE 0884-17)
  - UL 1577 component recognition program
  - IEC 62368-1, IEC 61010-1, IEC 60601-1 and GB 4943.1 certifications

## 2 Applications

- [Power supplies](#)
- [Grid, Electricity meter](#)
- [Motor drives](#)
- [Factory automation](#)
- [Building automation](#)
- [Lighting](#)
- [Appliances](#)

## 3 Description

The ISO6731 device is a high-performance, triple-channel digital isolators ideal for cost-sensitive applications requiring up to 5000 V<sub>RMS</sub> isolation ratings per UL 1577. This device is also certified by VDE, TUV, CSA, and CQC.

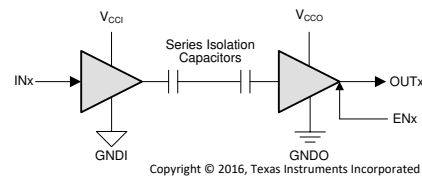
The ISO6731 devices provides high electromagnetic immunity and low emissions at low power consumption, while isolating CMOS or LVCMOS digital I/Os. Each isolation channel has a logic input and output buffer separated by TI's double capacitive silicon dioxide (SiO<sub>2</sub>) insulation barrier. This device comes with enable pins which can be used to put the respective outputs in high impedance for multi-master driving applications. The ISO6731 device has two forward and one reverse-direction channels. In the event of input power or signal loss, the default output is *high* for the device without suffix F and *low* for the device with suffix F. See [Device Functional Modes](#) section for further details.

Used in conjunction with isolated power supplies, this device helps prevent noise currents on data buses, such as UART, SPI, RS-485, RS-232, and CAN from damaging sensitive circuitry. Through innovative chip design and layout techniques, the electromagnetic compatibility of the ISO6731 device has been significantly enhanced to ease system-level ESD, EFT, surge, and emissions compliance. The ISO6731 device is available in a 16-pin SOIC wide-body (DW) package and is a pin-to-pin upgrade to the older generations.

### Device Information

PART NUMBER (1)	PACKAGE	BODY SIZE (NOM)
ISO6731, ISO6731F	SOIC (DW)	10.30 mm × 7.50 mm

- (1) For all available packages, see the orderable addendum at the end of the data sheet.



V<sub>CCI</sub>=Input supply, V<sub>CCO</sub>=Output supply  
 GNDI=Input ground, GNDO=Output ground

### Simplified Schematic



## Table of Contents

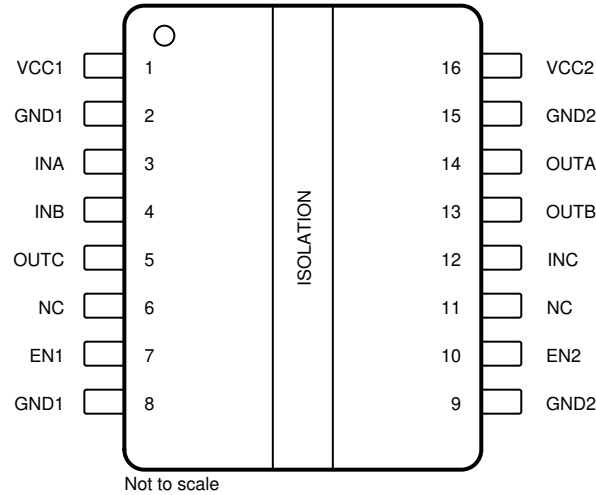
<b>1 Features</b> .....	1	6.19 Switching Characteristics—1.8-V Supply.....	16
<b>2 Applications</b> .....	1	6.20 Insulation Characteristics Curves.....	17
<b>3 Description</b> .....	1	6.21 Typical Characteristics.....	18
<b>4 Revision History</b> .....	2	<b>7 Parameter Measurement Information</b> .....	19
<b>5 Pin Configuration and Functions</b> .....	3	<b>8 Detailed Description</b> .....	21
<b>6 Specifications</b> .....	4	8.1 Overview.....	21
6.1 Absolute Maximum Ratings.....	4	8.2 Functional Block Diagram.....	21
6.2 ESD Ratings.....	4	8.3 Feature Description.....	22
6.3 Recommended Operating Conditions.....	5	8.4 Device Functional Modes.....	23
6.4 Thermal Information.....	6	<b>9 Application and Implementation</b> .....	24
6.5 Power Ratings.....	6	9.1 Application Information.....	24
6.6 Insulation Specifications.....	7	9.2 Typical Application.....	24
6.7 Safety-Related Certifications.....	8	<b>10 Power Supply Recommendations</b> .....	27
6.8 Safety Limiting Values.....	8	<b>11 Layout</b> .....	28
6.9 Electrical Characteristics—5-V Supply.....	9	11.1 Layout Guidelines.....	28
6.10 Supply Current Characteristics—5-V Supply.....	9	11.2 Layout Example.....	29
6.11 Electrical Characteristics—3.3-V Supply.....	10	<b>12 Device and Documentation Support</b> .....	30
6.12 Supply Current Characteristics—3.3-V Supply.....	10	12.1 Documentation Support.....	30
6.13 Electrical Characteristics—2.5-V Supply.....	11	12.2 Receiving Notification of Documentation Updates.....	30
6.14 Supply Current Characteristics—2.5-V Supply.....	11	12.3 Support Resources.....	30
Electrical Characteristics—1.8-V Supply.....	12	12.4 Trademarks.....	30
6.15 Supply Current Characteristics—1.8-V Supply.....	12	12.5 Electrostatic Discharge Caution.....	30
6.16 Switching Characteristics—5-V Supply.....	13	12.6 Glossary.....	30
6.17 Switching Characteristics—3.3-V Supply.....	14	<b>13 Mechanical, Packaging, and Orderable Information</b> .....	30
6.18 Switching Characteristics—2.5-V Supply.....	15		

## 4 Revision History

NOTE: Page numbers for previous revisions may differ from page numbers in the current version.

Changes from Revision A (March 2021) to Revision B (February 2023)	Page
• Changed standard name From: "DIN V VDE V 0884-11:2017-01" To: "DIN EN IEC 60747-17 (VDE 0884-17)" throughout the document.....	1
• Updated CMTI From: "50 kV/us (min) and 75 kV/us (typ)" To: "100 kV/us (min) and 150 kV/us (typ)" throughout the document.....	1
• Removed references to standard IEC/EN/CSA 60950-1 throughout the document.....	1
• Removed standard revision and year references as well as "certification pending" references from all standard names throughout the document.....	1
• Changed test conditions and value of Maximum surge isolation voltage ( $V_{IOSM}$ ) From: "6250 $V_{PK}$ " To: "10000 $V_{PK}$ " throughout document as per DIN EN IEC 60747-17 (VDE 0884-17).....	1
• Updated $V_{IORM}$ From: "1500 $V_{PK}$ " To: "2121 $V_{PK}$ " to match VDE certificate.....	7
• Updated $V_{IOWM}$ From: "1060 $V_{RMS}$ " To: "1500 $V_{RMS}$ " and From: "1500 $V_{DC}$ " To: "2121 $V_{DC}$ " throughout the document.....	7
• Added Maximum impulse voltage ( $V_{IMP}$ ) specification in Insulation Specifications per DIN EN IEC 60747-17 (VDE 0884-17).....	7
• Clarified method b test conditions of Apparent charge ( $q_{PD}$ ) in Insulation Specification.....	7
• Changed working voltage lifetime margin From: "87.5%" To: "50%", minimum required insulation lifetime From: "37.5 years" To: "30 years" and insulation lifetime per TDDb From: "220 years" To: "36 years" in <a href="#">Section 9.2.3.1</a> per DIN EN IEC 60747-17 (VDE 0884-17).....	26
• Changed <a href="#">Figure 9-8</a> per DIN EN IEC 60747-17 (VDE 0884-17).....	26
<b>Changes from Revision * (January 2021) to Revision A (March 2021)</b>	<b>Page</b>
• RTM release.....	1

## 5 Pin Configuration and Functions



**Figure 5-1. ISO6731 DW Package 16-Pin SOIC-WB Top View**

**Table 5-1. Pin Functions**

PIN		I/O	DESCRIPTION
NAME	ISO6731		
EN1	7	I	Output enable 1. Output pins on side 1 are enabled when EN1 is high or open and in high-impedance state when EN1 is low.
EN2	10	I	Output enable 2. Output pins on side 2 are enabled when EN2 is high or open and in high-impedance state when EN2 is low.
GND1	2, 8	—	Ground connection for $V_{CC1}$
GND2	9, 15	—	Ground connection for $V_{CC2}$
INA	3	I	Input, channel A
INB	4	I	Input, channel B
INC	12	I	Input, channel C
NC	6, 11		Not connected
OUTA	14	O	Output, channel A
OUTB	13	O	Output, channel B
OUTC	5	O	Output, channel C
$V_{CC1}$	1	—	Power supply, side 1
$V_{CC2}$	16	—	Power supply, side 2

## 6 Specifications

### 6.1 Absolute Maximum Ratings

See<sup>(1)</sup>

		MIN	MAX	UNIT
Supply voltage <sup>(2)</sup>	V <sub>CC1</sub> to GND1	-0.5	6	V
	V <sub>CC2</sub> to GND2	-0.5	6	
Input/Output Voltage	IN <sub>x</sub> to GND <sub>x</sub>	-0.5	V <sub>CCX</sub> + 0.5 <sup>(3)</sup>	V
	OUT <sub>x</sub> to GND <sub>x</sub>	-0.5	V <sub>CCX</sub> + 0.5 <sup>(3)</sup>	
Output current	I <sub>o</sub>	-15	15	mA
Temperature	Operating junction temperature, T <sub>J</sub>		150	°C
	Storage temperature, T <sub>stg</sub>	-65	150	°C

- (1) Stresses beyond those listed under Absolute Maximum Ratings may cause permanent damage to the device. These are stress ratings only, which do not imply functional operation of the device at these or any other conditions beyond those indicated under Recommended Operating Conditions. Exposure to absolute-maximum-rated conditions for extended periods may affect device reliability.
- (2) All voltage values except differential I/O bus voltages are with respect to the local ground terminal (GND1 or GND2) and are peak voltage values
- (3) Maximum voltage must not exceed 6 V.

### 6.2 ESD Ratings

			VALUE	UNIT
V <sub>(ESD)</sub>	Electrostatic discharge	Human body model (HBM), per ANSI/ESDA/JEDEC JS-001, all pins <sup>(1)</sup>	±6000	V
		Charged device model (CDM), per JEDEC specification JESD22-C101, all pins <sup>(2)</sup>	±1500	
		Contact discharge per IEC 61000-4-2; Isolation barrier withstand test <sup>(3) (4)</sup>	±8000	

- (1) JEDEC document JEP155 states that 500-V HBM allows safe manufacturing with a standard ESD control process.
- (2) JEDEC document JEP157 states that 250-V CDM allows safe manufacturing with a standard ESD control process.
- (3) IEC ESD strike is applied across the barrier with all pins on each side tied together creating a two-terminal device.
- (4) Testing is carried out in air or oil to determine the intrinsic contact discharge capability of the device.

### 6.3 Recommended Operating Conditions

over operating free-air temperature range (unless otherwise noted)

			MIN	NOM	MAX	UNIT
$V_{CC1}$ <sup>(1)</sup>	Supply Voltage Side 1	$V_{CC} = 1.8\text{ V}$	1.71		1.89	V
$V_{CC1}$ <sup>(1)</sup>	Supply Voltage Side 1	$V_{CC} = 2.5\text{ V to }5\text{ V}$	2.25		5.5	V
$V_{CC2}$ <sup>(1)</sup>	Supply Voltage Side 2	$V_{CC} = 1.8\text{ V}$	1.71		1.89	V
$V_{CC2}$ <sup>(1)</sup>	Supply Voltage Side 2	$V_{CC} = 2.5\text{ V to }5\text{ V}$	2.25		5.5	V
$V_{CC}$ (UVLO+)	UVLO threshold when supply voltage is rising			1.53	1.71	V
$V_{CC}$ (UVLO-)	UVLO threshold when supply voltage is falling		1.1	1.41		V
$V_{hys}$ (UVLO)	Supply voltage UVLO hysteresis		0.08	0.13		V
$V_{IH}$	High level Input voltage		$0.7 \times V_{CC1}$ <sup>(2)</sup>		$V_{CC1}$	V
$V_{IL}$	Low level Input voltage		0	$0.3 \times V_{CC1}$		V
$I_{OH}$	High level output current	$V_{CCO} = 5\text{ V}$ <sup>(2)</sup>	-4			mA
		$V_{CCO} = 3.3\text{ V}$	-2			mA
		$V_{CCO} = 2.5\text{ V}$	-1			mA
		$V_{CCO} = 1.8\text{ V}$	-1			mA
$I_{OL}$	Low level output current	$V_{CCO} = 5\text{ V}$			4	mA
		$V_{CCO} = 3.3\text{ V}$			2	mA
		$V_{CCO} = 2.5\text{ V}$			1	mA
		$V_{CCO} = 1.8\text{ V}$			1	mA
DR	Data Rate		0		50	Mbps
$T_A$	Ambient temperature		-40	25	125	°C

(1)  $V_{CC1}$  and  $V_{CC2}$  can be set independent of one another

(2)  $V_{CC1}$  = Input-side  $V_{CC}$ ;  $V_{CCO}$  = Output-side  $V_{CC}$

## 6.4 Thermal Information

THERMAL METRIC <sup>(1)</sup>		ISO673x	UNIT
		DW (SOIC)	
		16 PINS	
$R_{\theta JA}$	Junction-to-ambient thermal resistance	73	°C/W
$R_{\theta JC(top)}$	Junction-to-case (top) thermal resistance	36.1	°C/W
$R_{\theta JB}$	Junction-to-board thermal resistance	40.4	°C/W
$\Psi_{JT}$	Junction-to-top characterization parameter	17	°C/W
$\Psi_{JB}$	Junction-to-board characterization parameter	39.9	°C/W
$R_{\theta JC(bot)}$	Junction-to-case (bottom) thermal resistance	—	°C/W

(1) For more information about traditional and new thermal metrics, see the [Semiconductor and IC Package Thermal Metrics application report](#).

## 6.5 Power Ratings

PARAMETER		TEST CONDITIONS	MIN	TYP	MAX	UNIT
<b>ISO6731</b>						
$P_D$	Maximum power dissipation (both sides)	$V_{CC1} = V_{CC2} = 5.5\text{ V}$ , $T_J = 150^\circ\text{C}$ , $C_L = 15\text{ pF}$ , Input a 25-MHz 50% duty cycle square wave			117.5	mW
$P_{D1}$	Maximum power dissipation (side-1)				47.7	mW
$P_{D2}$	Maximum power dissipation (side-2)				69.8	mW

## 6.6 Insulation Specifications

PARAMETER		TEST CONDITIONS	VALUE	UNIT
			DW-16	
CLR	External clearance <sup>(1)</sup>	Shortest terminal-to-terminal distance through air	>8	mm
CPG	External creepage <sup>(1)</sup>	Shortest terminal-to-terminal distance across the package surface	>8	mm
DTI	Distance through the insulation	Minimum internal gap (internal clearance)	>17	µm
CTI	Comparative tracking index	DIN EN 60112 (VDE 0303-11); IEC 60112	>600	V
	Material group	According to IEC 60664-1	I	
	Overvoltage category per IEC 60664-1	Rated mains voltage ≤ 600 V <sub>RMS</sub>	I-IV	
		Rated mains voltage ≤ 1000 V <sub>RMS</sub>	I-III	
<b>DIN EN IEC 60747-17 (VDE 0884-17) <sup>(2)</sup></b>				
V <sub>IORM</sub>	Maximum repetitive peak isolation voltage	AC voltage (bipolar)	2121	V <sub>PK</sub>
V <sub>IOWM</sub>	Maximum working isolation voltage	AC voltage; Time dependent dielectric breakdown (TDDDB) Test; See <a href="#">Figure 9-8</a>	1500	V <sub>RMS</sub>
		DC voltage	2121	V <sub>DC</sub>
V <sub>IOTM</sub>	Maximum transient isolation voltage	V <sub>TEST</sub> = V <sub>IOTM</sub> , t = 60 s (qualification); V <sub>TEST</sub> = 1.2 x V <sub>IOTM</sub> , t = 1 s (100% production)	7071	V <sub>PK</sub>
V <sub>IMP</sub>	Maximum impulse voltage <sup>(3)</sup>	Tested in air, 1.2/50-µs waveform per IEC 62368-1	7692	V <sub>PK</sub>
V <sub>IOSM</sub>	Maximum surge isolation voltage <sup>(4)</sup>	V <sub>IOSM</sub> ≥ 1.3 x V <sub>IMP</sub> ; tested in oil (qualification test), 1.2/50-µs waveform per IEC 62368-1	10000	V <sub>PK</sub>
q <sub>pd</sub>	Apparent charge <sup>(5)</sup>	Method a, After Input-output safety test subgroup 2/3, V <sub>ini</sub> = V <sub>IOTM</sub> , t <sub>ini</sub> = 60 s; V <sub>pd(m)</sub> = 1.2 x V <sub>IORM</sub> , t <sub>m</sub> = 10 s	≤5	pC
		Method a, After environmental tests subgroup 1, V <sub>ini</sub> = V <sub>IOTM</sub> , t <sub>ini</sub> = 60 s; V <sub>pd(m)</sub> = 1.6 x V <sub>IORM</sub> , t <sub>m</sub> = 10 s	≤5	
		Method b: At routine test (100% production) and preconditioning (type test); V <sub>ini</sub> = 1.2 x V <sub>IOTM</sub> , t <sub>ini</sub> = 1 s; V <sub>pd(m)</sub> = 1.875 x V <sub>IORM</sub> , t <sub>m</sub> = 1 s (method b1) or V <sub>pd(m)</sub> = V <sub>ini</sub> , t <sub>m</sub> = t <sub>ini</sub> (method b2)	≤5	
C <sub>IO</sub>	Barrier capacitance, input to output <sup>(6)</sup>	V <sub>IO</sub> = 0.4 x sin(2πft), f = 1 MHz	~1	pF
R <sub>IO</sub>	Isolation resistance <sup>(6)</sup>	V <sub>IO</sub> = 500 V, T <sub>A</sub> = 25°C	>10 <sup>12</sup>	Ω
		V <sub>IO</sub> = 500 V, 100°C ≤ T <sub>A</sub> ≤ 125°C	>10 <sup>11</sup>	
		V <sub>IO</sub> = 500 V at T <sub>S</sub> = 150°C	>10 <sup>9</sup>	
	Pollution degree		2	
	Climatic category		40/125/21	
<b>UL 1577</b>				
V <sub>ISO</sub>	Maximum withstanding isolation voltage	V <sub>TEST</sub> = V <sub>ISO</sub> , t = 60 s (qualification), V <sub>TEST</sub> = 1.2 x V <sub>ISO</sub> , t = 1 s (100% production)	5000	V <sub>RMS</sub>

- (1) Creepage and clearance requirements should be applied according to the specific equipment isolation standards of an application. Care should be taken to maintain the creepage and clearance distance of a board design to ensure that the mounting pads of the isolator on the printed-circuit board do not reduce this distance. Creepage and clearance on a printed-circuit board become equal in certain cases. Techniques such as inserting grooves and/or ribs on a printed-circuit board are used to help increase these specifications.
- (2) This coupler is suitable for *safe electrical insulation* only within the safety ratings. Compliance with the safety ratings shall be ensured by means of suitable protective circuits.
- (3) Testing is carried out in air to determine the surge immunity of the package.
- (4) Testing is carried out in oil to determine the intrinsic surge immunity of the isolation barrier.
- (5) Apparent charge is electrical discharge caused by a partial discharge (pd).
- (6) All pins on each side of the barrier tied together creating a two-terminal device.

## 6.7 Safety-Related Certifications

VDE	CSA	UL	CQC	TUV
Certified according to DIN EN IEC 60747-17 (VDE 0884-17)	Certified according to IEC 62368-1, IEC 61010-1 and IEC 60601	Certified according to UL 1577 Component Recognition Program	Certified according to GB 4943.1	Certified according to EN 61010-1 and EN 62368-1
Maximum transient isolation voltage, 7071 V <sub>PK</sub> ; Maximum repetitive peak isolation voltage, 2121 V <sub>PK</sub> ; Maximum surge isolation voltage, 10000 V <sub>PK</sub>	5000 V <sub>RMS</sub> insulation per CSA 62368-1, IEC 62368-1, CSA 61010-1 and IEC 61010-1, 1000 V <sub>RMS</sub> basic and 600 V <sub>RMS</sub> reinforced working voltage (pollution degree 2, material group I); 5000 V <sub>RMS</sub> insulation per CSA 60601-1 and IEC 60601-1, 2 MOPP for 250 V <sub>RMS</sub>	Single protection, 5000 V <sub>RMS</sub>	Reinforced insulation, Altitude ≤ 5000 m, Tropical Climate, 700 V <sub>RMS</sub> maximum working voltage	5000 V <sub>RMS</sub> reinforced insulation per EN 61010-1 and EN 62368-1 up to working voltage of 600 V <sub>RMS</sub>
Certificate number: 40040142	Master contract number: 220991	File number: E181974	Certificate number: CQC21001304083	Client ID number: 077311

## 6.8 Safety Limiting Values

Safety limiting<sup>(1)</sup> intends to minimize potential damage to the isolation barrier upon failure of input or output circuitry.

PARAMETER		TEST CONDITIONS	MIN	TYP	MAX	UNIT
<b>DW-16 PACKAGE</b>						
I <sub>S</sub>	Safety input, output, or supply current	R <sub>θJA</sub> = 73°C/W, V <sub>I</sub> = 5.5 V, T <sub>J</sub> = 150°C, T <sub>A</sub> = 25°C See <a href="#">Figure 6-1</a>			311.4	mA
		R <sub>θJA</sub> = 73°C/W, V <sub>I</sub> = 3.6 V, T <sub>J</sub> = 150°C, T <sub>A</sub> = 25°C See <a href="#">Figure 6-1</a>			475.7	mA
		R <sub>θJA</sub> = 73°C/W, V <sub>I</sub> = 2.75 V, T <sub>J</sub> = 150°C, T <sub>A</sub> = 25°C See <a href="#">Figure 6-1</a>			622	
		R <sub>θJA</sub> = 73°C/W, V <sub>I</sub> = 1.89 V, T <sub>J</sub> = 150°C, T <sub>A</sub> = 25°C See <a href="#">Figure 6-1</a>			905.1	mA
P <sub>S</sub>	Safety input, output, or total power	R <sub>θJA</sub> = 73°C/W, T <sub>J</sub> = 150°C, T <sub>A</sub> = 25°C See <a href="#">Figure 6-2</a>			1712.4	mW
T <sub>S</sub>	Maximum safety temperature				150	°C

- (1) The maximum safety temperature, T<sub>S</sub>, has the same value as the maximum junction temperature, T<sub>J</sub>, specified for the device. The I<sub>S</sub> and P<sub>S</sub> parameters represent the safety current and safety power respectively. The maximum limits of I<sub>S</sub> and P<sub>S</sub> should not be exceeded. These limits vary with the ambient temperature, T<sub>A</sub>.  
The junction-to-air thermal resistance, R<sub>θJA</sub>, in the table is that of a device installed on a high-K test board for leaded surface-mount packages. Use these equations to calculate the value for each parameter:  
T<sub>J</sub> = T<sub>A</sub> + R<sub>θJA</sub> × P, where P is the power dissipated in the device.  
T<sub>J(max)</sub> = T<sub>S</sub> = T<sub>A</sub> + R<sub>θJA</sub> × P<sub>S</sub>, where T<sub>J(max)</sub> is the maximum allowed junction temperature.  
P<sub>S</sub> = I<sub>S</sub> × V<sub>I</sub>, where V<sub>I</sub> is the maximum input voltage.

## 6.9 Electrical Characteristics—5-V Supply

$V_{CC1} = V_{CC2} = 5\text{ V} \pm 10\%$  (over recommended operating conditions unless otherwise noted)

PARAMETER		TEST CONDITIONS	MIN	TYP	MAX	UNIT
$V_{OH}$	High-level output voltage	$I_{OH} = -4\text{ mA}$ ; See <a href="#">Figure 7-1</a>	$V_{CCO} - 0.4$ <sup>(1)</sup>			V
$V_{OL}$	Low-level output voltage	$I_{OL} = 4\text{ mA}$ ; See <a href="#">Figure 7-1</a>			0.4	V
$V_{IT+(IN)}$	Rising input switching threshold			$0.7 \times V_{CCI}$ <sup>(1)</sup>		V
$V_{IT-(IN)}$	Falling input switching threshold		$0.3 \times V_{CCI}$			V
$V_{I(HYS)}$	Input threshold voltage hysteresis		$0.1 \times V_{CCI}$			V
$I_{IH}$	High-level input current	$V_{IH} = V_{CCI}$ <sup>(1)</sup> at INx			10	$\mu\text{A}$
$I_{IL}$	Low-level input current	$V_{IL} = 0\text{ V}$ at INx	-10			$\mu\text{A}$
$I_{IH}$	High-level input current	$V_{IH} = V_{CCI}$ <sup>(1)</sup> at ENx			28	$\mu\text{A}$
$I_{IL}$	Low-level input current	$V_{IL} = 0\text{ V}$ at ENx	-28			$\mu\text{A}$
CMTI	Common mode transient immunity	$V_I = V_{CC}$ or $0\text{ V}$ , $V_{CM} = 1200\text{ V}$ ; See <a href="#">Figure 7-1</a>	100	150		kV/us
$C_i$	Input Capacitance <sup>(2)</sup>	$V_I = V_{CC}/2 + 0.4 \times \sin(2\pi ft)$ , $f = 2\text{ MHz}$ , $V_{CC} = 5\text{ V}$		2.8		pF

(1)  $V_{CCI}$  = Input-side  $V_{CC}$ ;  $V_{CCO}$  = Output-side  $V_{CC}$

(2) Measured from input pin to same side ground.

## 6.10 Supply Current Characteristics—5-V Supply

$V_{CC1} = V_{CC2} = 5\text{ V} \pm 10\%$  (over recommended operating conditions unless otherwise noted)

PARAMETER	TEST CONDITIONS	SUPPLY CURRENT	MIN	TYP	MAX	UNIT	
<b>ISO6731</b>							
Supply current - DC signal <sup>(2)</sup>	$V_I = V_{CCI}$ <sup>(1)</sup> (ISO6731); $V_I = 0\text{ V}$ (ISO6731 with F suffix)	$I_{CC1}$		1.9	2.8	mA	
		$I_{CC2}$		2.2	3.5		
	$V_I = 0\text{ V}$ (ISO6731); $V_I = V_{CC1}$ (ISO6731 with F suffix)	$I_{CC1}$		4.1	5.8		
		$I_{CC2}$		3.5	5.3		
Supply current - AC signal <sup>(3)</sup>	All channels switching with square wave clock input; $C_L = 15\text{ pF}$	1 Mbps	$I_{CC1}$		2.9		4.2
			$I_{CC2}$		3.0		4.8
		10 Mbps	$I_{CC1}$		3.4		4.8
			$I_{CC2}$		4.2		6.1
		50 Mbps	$I_{CC1}$		6.1	7.9	
			$I_{CC2}$		9.4	11.9	

(1)  $V_{CCI}$  = Input-side  $V_{CC}$

(2) Supply current valid for ENx =  $V_{CCx}$  and ENx = 0V

(3) Supply current valid for ENx =  $V_{CCx}$

## 6.11 Electrical Characteristics—3.3-V Supply

 $V_{CC1} = V_{CC2} = 3.3\text{ V} \pm 10\%$  (over recommended operating conditions unless otherwise noted)

PARAMETER		TEST CONDITIONS	MIN	TYP	MAX	UNIT
$V_{OH}$	High-level output voltage	$I_{OH} = -2\text{mA}$ ; See <a href="#">Figure 7-1</a>	$V_{CCO} - 0.2$ <sup>(1)</sup>			V
$V_{OL}$	Low-level output voltage	$I_{OL} = 2\text{mA}$ ; See <a href="#">Figure 7-1</a>			0.2	V
$V_{IT+(IN)}$	Rising input switching threshold			$0.7 \times V_{CCI}$ <sup>(1)</sup>		V
$V_{IT-(IN)}$	Falling input switching threshold		$0.3 \times V_{CCI}$			V
$V_{I(HYS)}$	Input threshold voltage hysteresis		$0.1 \times V_{CCI}$			V
$I_{IH}$	High-level input current	$V_{IH} = V_{CCI}$ <sup>(1)</sup> at INx			10	$\mu\text{A}$
$I_{IL}$	Low-level input current	$V_{IL} = 0\text{ V}$ at INx	-10			$\mu\text{A}$
$I_{IH}$	High-level input current	$V_{IH} = V_{CCI}$ <sup>(1)</sup> at ENx			30	$\mu\text{A}$
$I_{IL}$	Low-level input current	$V_{IL} = 0\text{ V}$ at ENx	-30			$\mu\text{A}$
CMTI	Common mode transient immunity	$V_I = V_{CC}$ or $0\text{ V}$ , $V_{CM} = 1200\text{ V}$ ; See <a href="#">Figure 7-1</a>	100	150		kV/us
$C_i$	Input Capacitance <sup>(2)</sup>	$V_I = V_{CC}/2 + 0.4 \times \sin(2\pi ft)$ , $f = 2\text{ MHz}$ , $V_{CC} = 3.3\text{ V}$		2.8		pF

(1)  $V_{CCI}$  = Input-side  $V_{CC}$ ;  $V_{CCO}$  = Output-side  $V_{CC}$

(2) Measured from input pin to same side ground.

## 6.12 Supply Current Characteristics—3.3-V Supply

 $V_{CC1} = V_{CC2} = 3.3\text{ V} \pm 10\%$  (over recommended operating conditions unless otherwise noted)

PARAMETER	TEST CONDITIONS	SUPPLY CURRENT	MIN	TYP	MAX	UNIT	
<b>ISO6731</b>							
Supply current - DC signal <sup>(2)</sup>	$V_I = V_{CCI}$ <sup>(1)</sup> (ISO6731); $V_I = 0\text{ V}$ (ISO6731 with F suffix)	$I_{CC1}$		1.9	2.7	mA	
		$I_{CC2}$		2.2	3.4		
	$V_I = 0\text{ V}$ (ISO6731); $V_I = V_{CC1}$ (ISO6731 with F suffix)	$I_{CC1}$		4.0	5.8		
		$I_{CC2}$		3.5	5.3		
Supply current - AC signal <sup>(3)</sup>	All channels switching with square wave clock input; $C_L = 15\text{ pF}$	1 Mbps	$I_{CC1}$		2.8		4.1
			$I_{CC2}$		3.0		4.7
		10 Mbps	$I_{CC1}$		3.2		4.6
			$I_{CC2}$		3.8		5.7
		50 Mbps	$I_{CC1}$		5.1	6.8	
			$I_{CC2}$		7.5	9.9	

(1)  $V_{CCI}$  = Input-side  $V_{CC}$

(2) Supply current valid for ENx =  $V_{CCx}$  and ENx = 0V

(3) Supply current valid for ENx =  $V_{CCx}$

### 6.13 Electrical Characteristics—2.5-V Supply

$V_{CC1} = V_{CC2} = 2.5\text{ V} \pm 10\%$  (over recommended operating conditions unless otherwise noted)

PARAMETER		TEST CONDITIONS	MIN	TYP	MAX	UNIT
$V_{OH}$	High-level output voltage	$I_{OH} = -1\text{mA}$ ; See <a href="#">Figure 7-1</a>	$V_{CCO} - 0.1$ <sup>(1)</sup>			V
$V_{OL}$	Low-level output voltage	$I_{OL} = 1\text{mA}$ ; See <a href="#">Figure 7-1</a>			0.1	V
$V_{IT+(IN)}$	Rising input switching threshold			$0.7 \times V_{CCI}$ <sup>(1)</sup>		V
$V_{IT-(IN)}$	Falling input switching threshold		$0.3 \times V_{CCI}$			V
$V_{I(HYS)}$	Input threshold voltage hysteresis		$0.1 \times V_{CCI}$			V
$I_{IH}$	High-level input current	$V_{IH} = V_{CCI}$ <sup>(1)</sup> at INx			10	$\mu\text{A}$
$I_{IL}$	Low-level input current	$V_{IL} = 0\text{ V}$ at INx	-10			$\mu\text{A}$
$I_{IH}$	High-level input current	$V_{IH} = V_{CCI}$ <sup>(1)</sup> at ENx			30	$\mu\text{A}$
$I_{IL}$	Low-level input current	$V_{IL} = 0\text{ V}$ at ENx	-30			$\mu\text{A}$
CMTI	Common mode transient immunity	$V_I = V_{CC}$ or $0\text{ V}$ , $V_{CM} = 1200\text{ V}$ ; See <a href="#">Figure 7-1</a>	100	150		kV/us
$C_i$	Input Capacitance <sup>(2)</sup>	$V_I = V_{CC}/2 + 0.4 \times \sin(2\pi f t)$ , $f = 2\text{ MHz}$ , $V_{CC} = 2.5\text{ V}$		2.8		pF

- (1)  $V_{CCI}$  = Input-side  $V_{CC}$ ;  $V_{CCO}$  = Output-side  $V_{CC}$   
(2) Measured from input pin to same side ground.

### 6.14 Supply Current Characteristics—2.5-V Supply

$V_{CC1} = V_{CC2} = 2.5\text{ V} \pm 10\%$  (over recommended operating conditions unless otherwise noted)

PARAMETER	TEST CONDITIONS	SUPPLY CURRENT	MIN	TYP	MAX	UNIT	
<b>ISO6731</b>							
Supply current - DC signal <sup>(2)</sup>	$V_I = V_{CCI}$ <sup>(1)</sup> (ISO6731); $V_I = 0\text{ V}$ (ISO6731 with F suffix)	$I_{CC1}$		1.9	2.7	mA	
		$I_{CC2}$		2.2	3.4		
	$V_I = 0\text{ V}$ (ISO6731); $V_I = V_{CC1}$ (ISO6731 with F suffix)	$I_{CC1}$		4.0	5.7		
		$I_{CC2}$		3.5	5.3		
Supply current - AC signal <sup>(3)</sup>	All channels switching with square wave clock input; $C_L = 15\text{ pF}$	1 Mbps	$I_{CC1}$		2.8		4.1
			$I_{CC2}$		3.0		4.7
		10 Mbps	$I_{CC1}$		3.1		4.5
			$I_{CC2}$		3.6		5.4
		50 Mbps	$I_{CC1}$		4.5	6.2	
			$I_{CC2}$		6.4	8.7	

- (1)  $V_{CCI}$  = Input-side  $V_{CC}$   
(2) Supply current valid for ENx =  $V_{CCx}$  and ENx =  $0\text{V}$   
(3) Supply current valid for ENx =  $V_{CCx}$

## Electrical Characteristics—1.8-V Supply

$V_{CC1} = V_{CC2} = 1.8 \text{ V} \pm 5\%$  (over recommended operating conditions unless otherwise noted)

PARAMETER		TEST CONDITIONS	MIN	TYP	MAX	UNIT
$V_{OH}$	High-level output voltage	$I_{OH} = -1 \text{ mA}$ ; See <a href="#">Figure 7-1</a>	$V_{CCO} - 0.1$ <sup>(1)</sup>			V
$V_{OL}$	Low-level output voltage	$I_{OL} = 1 \text{ mA}$ ; See <a href="#">Figure 7-1</a>			0.1	V
$V_{IT+(IN)}$	Rising input switching threshold			$0.7 \times V_{CCI}$ <sup>(1)</sup>		V
$V_{IT-(IN)}$	Falling input switching threshold		$0.3 \times V_{CCI}$			V
$V_{I(HYS)}$	Input threshold voltage hysteresis		$0.1 \times V_{CCI}$			V
$I_{IH}$	High-level input current	$V_{IH} = V_{CCI}$ <sup>(1)</sup> at INx			10	$\mu\text{A}$
$I_{IL}$	Low-level input current	$V_{IL} = 0 \text{ V}$ at INx	-10			$\mu\text{A}$
$I_{IH}$	High-level input current	$V_{IH} = V_{CCI}$ <sup>(1)</sup> at ENx			30	$\mu\text{A}$
$I_{IL}$	Low-level input current	$V_{IL} = 0 \text{ V}$ at ENx	-30			$\mu\text{A}$
CMTI	Common mode transient immunity	$V_I = V_{CC}$ or $0 \text{ V}$ , $V_{CM} = 1200 \text{ V}$ ; See <a href="#">Figure 7-1</a>	100	150		kV/us
$C_i$	Input Capacitance <sup>(2)</sup>	$V_I = V_{CC}/2 + 0.4 \times \sin(2\pi ft)$ , $f = 2 \text{ MHz}$ , $V_{CC} = 1.8 \text{ V}$		2.8		pF

(1)  $V_{CCI}$  = Input-side  $V_{CC}$ ;  $V_{CCO}$  = Output-side  $V_{CC}$

(2) Measured from input pin to same side ground.

## 6.15 Supply Current Characteristics—1.8-V Supply

$V_{CC1} = V_{CC2} = 1.8 \text{ V} \pm 5\%$  (over recommended operating conditions unless otherwise noted)

PARAMETER	TEST CONDITIONS	SUPPLY CURRENT	MIN	TYP	MAX	UNIT	
<b>ISO6731</b>							
Supply current - DC signal <sup>(2)</sup>	$V_I = V_{CCI}$ <sup>(1)</sup> (ISO6731); $V_I = 0 \text{ V}$ (ISO6731 with F suffix)	$I_{CC1}$		1.5	2.4	mA	
		$I_{CC2}$		2	3.4		
	$V_I = 0 \text{ V}$ (ISO6731); $V_I = V_{CC1}$ (ISO6731 with F suffix)	$I_{CC1}$		3.4	5.4		
		$I_{CC2}$		3.2	5.3		
Supply current - AC signal <sup>(3)</sup>	All channels switching with square wave clock input; $C_L = 15 \text{ pF}$	1 Mbps	$I_{CC1}$		2.4		3.8
			$I_{CC2}$		2.7		4.6
		10 Mbps	$I_{CC1}$		2.6		4.1
			$I_{CC2}$		3.2		5.1
		50 Mbps	$I_{CC1}$		3.7	5.3	
			$I_{CC2}$		5.2	7.4	

(1)  $V_{CCI}$  = Input-side  $V_{CC}$

(2) Supply current valid for ENx =  $V_{CCx}$  and ENx = 0V

(3) Supply current valid for ENx =  $V_{CCx}$

## 6.16 Switching Characteristics—5-V Supply

$V_{CC1} = V_{CC2} = 5\text{ V} \pm 10\%$  (over recommended operating conditions unless otherwise noted)

PARAMETER		TEST CONDITIONS	MIN	TYP	MAX	UNIT
$t_{PLH}$ , $t_{PHL}$	Propagation delay time	@ 100 kbps See <a href="#">Figure 7-1</a>		11	18	ns
PWD	Pulse width distortion <sup>(1)</sup> $ t_{PHL} - t_{PLH} $			0.2	7	ns
$t_{sk(o)}$	Channel-to-channel output skew time <sup>(2)</sup>	Same-direction channels			6	ns
$t_{sk(pp)}$	Part-to-part skew time <sup>(3)</sup>				6	ns
$t_r$	Output signal rise time	See <a href="#">Figure 7-1</a>		2.6	4.5	ns
$t_f$	Output signal fall time			2.6	4.5	ns
$t_{PHZ}$	Disable propagation delay, high-to-high impedance output	See <a href="#">Figure 7-2</a>		18.6	25.8	ns
$t_{PLZ}$	Disable propagation delay, low-to-high impedance output			18.6	25.8	ns
$t_{PZH}$	Enable propagation delay, high impedance-to-high output for ISO673x			14.2	21.1	ns
$t_{PZL}$	Enable propagation delay, high impedance-to-low output for ISO673x			14.2	21.1	ns
$t_{PU}$	Time from UVLO to valid output data				300	$\mu$ s
$t_{DO}$	Default output delay time from input power loss	Measured from the time VCC goes below 1.2 V. See <a href="#">Figure 7-3</a>		0.1	0.3	$\mu$ s
$t_{ie}$	Time interval error	$2^{16} - 1$ PRBS data at 50 Mbps		1		ns

- (1) Also known as pulse skew.
- (2)  $t_{sk(o)}$  is the skew between outputs of a single device with all driving inputs connected together and the outputs switching in the same direction while driving identical loads.
- (3)  $t_{sk(pp)}$  is the magnitude of the difference in propagation delay times between any terminals of different devices switching in the same direction while operating at identical supply voltages, temperature, input signals and loads.

## 6.17 Switching Characteristics—3.3-V Supply

 $V_{CC1} = V_{CC2} = 3.3\text{ V} \pm 10\%$  (over recommended operating conditions unless otherwise noted)

PARAMETER		TEST CONDITIONS	MIN	TYP	MAX	UNIT
$t_{PLH}$ , $t_{PHL}$	Propagation delay time	@100kbps See <a href="#">Figure 7-1</a>		11	18	ns
PWD	Pulse width distortion <sup>(1)</sup> $ t_{PHL} - t_{PLH} $			0.5	7	ns
$t_{sk(o)}$	Channel-to-channel output skew time <sup>(2)</sup>	Same-direction channels			6	ns
$t_{sk(pp)}$	Part-to-part skew time <sup>(3)</sup>				7	ns
$t_r$	Output signal rise time	See <a href="#">Figure 7-1</a>		1.6	3.2	ns
$t_f$	Output signal fall time			1.6	3.2	ns
$t_{PHZ}$	Disable propagation delay, high-to-high impedance output	See <a href="#">Figure 7-2</a>		23.2	34.4	ns
$t_{PLZ}$	Disable propagation delay, low-to-high impedance output			23.2	34.4	ns
$t_{PZH}$	Enable propagation delay, high impedance-to-high output for ISO673x			16.6	23	ns
$t_{PZL}$	Enable propagation delay, high impedance-to-low output for ISO673x			16.6	23	ns
$t_{PU}$	Time from UVLO to valid output data				300	$\mu$ s
$t_{DO}$	Default output delay time from input power loss	Measured from the time VCC goes below 1.2V. See <a href="#">Figure 7-3</a>		0.1	0.3	$\mu$ s
$t_{ie}$	Time interval error	$2^{16} - 1$ PRBS data at 50 Mbps		1		ns

- (1) Also known as pulse skew.
- (2)  $t_{sk(o)}$  is the skew between outputs of a single device with all driving inputs connected together and the outputs switching in the same direction while driving identical loads.
- (3)  $t_{sk(pp)}$  is the magnitude of the difference in propagation delay times between any terminals of different devices switching in the same direction while operating at identical supply voltages, temperature, input signals and loads.

## 6.18 Switching Characteristics—2.5-V Supply

$V_{CC1} = V_{CC2} = 2.5\text{ V} \pm 10\%$  (over recommended operating conditions unless otherwise noted)

PARAMETER		TEST CONDITIONS	MIN	TYP	MAX	UNIT
$t_{PLH}$ , $t_{PHL}$	Propagation delay time	@100kbps See <a href="#">Figure 7-1</a>		12	20.5	ns
PWD	Pulse width distortion <sup>(1)</sup> $ t_{PHL} - t_{PLH} $			0.6	7.1	ns
$t_{sk(o)}$	Channel-to-channel output skew time <sup>(2)</sup>	Same-direction channels			6	ns
$t_{sk(pp)}$	Part-to-part skew time <sup>(3)</sup>				7	ns
$t_r$	Output signal rise time	See <a href="#">Figure 7-1</a>		2	4	ns
$t_f$	Output signal fall time			2	4	ns
$t_{PHZ}$	Disable propagation delay, high-to-high impedance output	See <a href="#">Figure 7-2</a>		28.1	43	ns
$t_{PLZ}$	Disable propagation delay, low-to-high impedance output			28.1	43	ns
$t_{PZH}$	Enable propagation delay, high impedance-to-high output for ISO673x			20.4	36.3	ns
$t_{PZL}$	Enable propagation delay, high impedance-to-low output for ISO673x			20.4	36.3	ns
$t_{PU}$	Time from UVLO to valid output data				300	$\mu$ s
$t_{DO}$	Default output delay time from input power loss	Measured from the time VCC goes below 1.2V. See <a href="#">Figure 7-3</a>		0.1	0.3	$\mu$ s
$t_{ie}$	Time interval error	$2^{16} - 1$ PRBS data at 50 Mbps		1		ns

- (1) Also known as pulse skew.
- (2)  $t_{sk(o)}$  is the skew between outputs of a single device with all driving inputs connected together and the outputs switching in the same direction while driving identical loads.
- (3)  $t_{sk(pp)}$  is the magnitude of the difference in propagation delay times between any terminals of different devices switching in the same direction while operating at identical supply voltages, temperature, input signals and loads.

## 6.19 Switching Characteristics—1.8-V Supply

 $V_{CC1} = V_{CC2} = 1.8\text{ V} \pm 5\%$  (over recommended operating conditions unless otherwise noted)

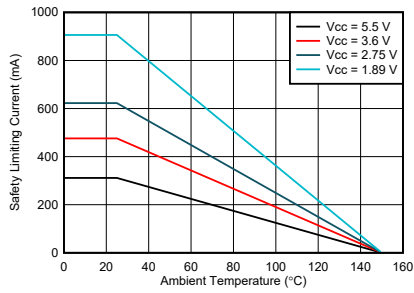
PARAMETER		TEST CONDITIONS	MIN	TYP	MAX	UNIT
$t_{PLH}$ , $t_{PHL}$	Propagation delay time	@100kbps See <a href="#">Figure 7-1</a>		15	24	ns
PWD	Pulse width distortion <sup>(1)</sup> $ t_{PHL} - t_{PLH} $			0.7	8.2	ns
$t_{sk(o)}$	Channel-to-channel output skew time <sup>(2)</sup>	Same-direction channels			6	ns
$t_{sk(pp)}$	Part-to-part skew time <sup>(3)</sup>				8.8	ns
$t_r$	Output signal rise time	See <a href="#">Figure 7-1</a>		2.7	5.3	ns
$t_f$	Output signal fall time			2.7	5.3	ns
$t_{PHZ}$	Disable propagation delay, high-to-high impedance output	See <a href="#">Figure 7-2</a>		40.3	63	ns
$t_{PLZ}$	Disable propagation delay, low-to-high impedance output			40.3	63	ns
$t_{PZH}$	Enable propagation delay, high impedance-to-high output for ISO673x			31	51.4	ns
$t_{PZL}$	Enable propagation delay, high impedance-to-low output for ISO673x			31	51.4	ns
$t_{PU}$	Time from UVLO to valid output data				300	$\mu$ s
$t_{DO}$	Default output delay time from input power loss	Measured from the time VCC goes below 1.2V. See <a href="#">Figure 7-3</a>		0.1	0.3	$\mu$ s
$t_{ie}$	Time interval error	$2^{16} - 1$ PRBS data at 50 Mbps		1		ns

(1) Also known as pulse skew.

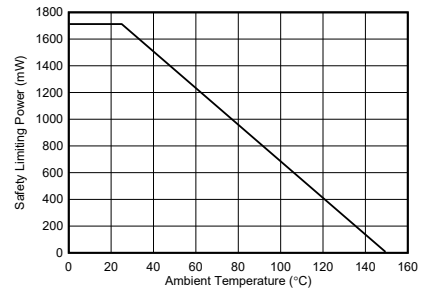
(2)  $t_{sk(o)}$  is the skew between outputs of a single device with all driving inputs connected together and the outputs switching in the same direction while driving identical loads.

(3)  $t_{sk(pp)}$  is the magnitude of the difference in propagation delay times between any terminals of different devices switching in the same direction while operating at identical supply voltages, temperature, input signals and loads.

## 6.20 Insulation Characteristics Curves

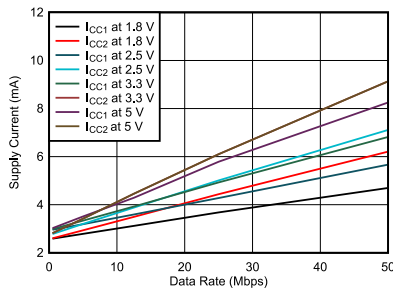


**Figure 6-1. Thermal Derating Curve for Safety Limiting Current for DW-16 Package**



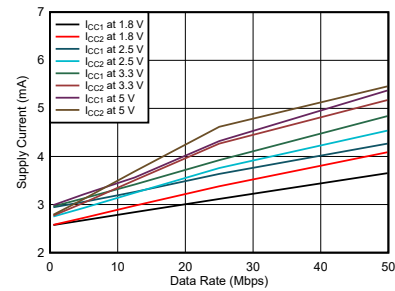
**Figure 6-2. Thermal Derating Curve for Safety Limiting Power for DW-16 Package**

## 6.21 Typical Characteristics



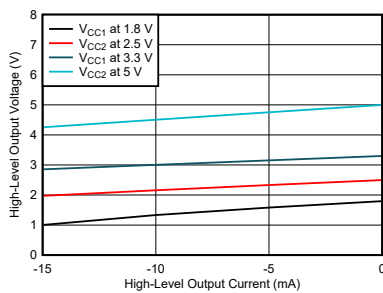
$T_A = 25^\circ\text{C}$   $C_L = 15\text{ pF}$

**Figure 6-3. ISO6731 Supply Current vs Data Rate (With 15-pF Load)**



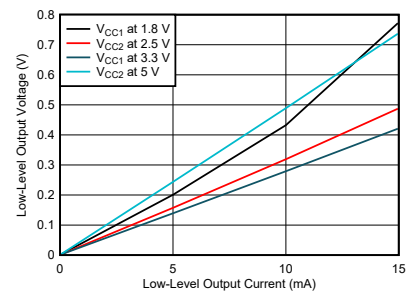
$T_A = 25^\circ\text{C}$   $C_L = \text{No Load}$

**Figure 6-4. ISO6731 Supply Current vs Data Rate (With No Load)**



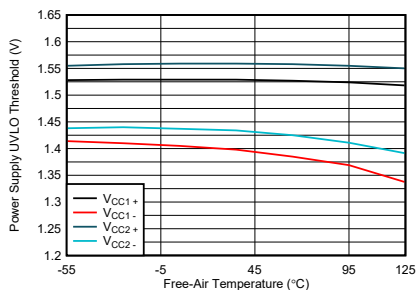
$T_A = 25^\circ\text{C}$

**Figure 6-5. High-Level Output Voltage vs High-level Output Current**

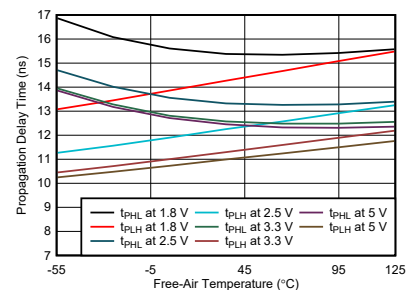


$T_A = 25^\circ\text{C}$

**Figure 6-6. Low-Level Output Voltage vs Low-Level Output Current**

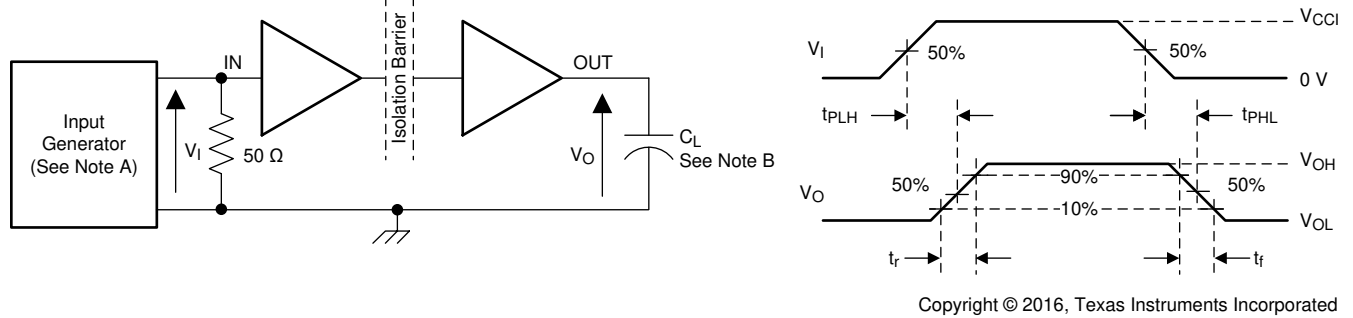


**Figure 6-7. Power Supply Undervoltage Threshold vs Free-Air Temperature**



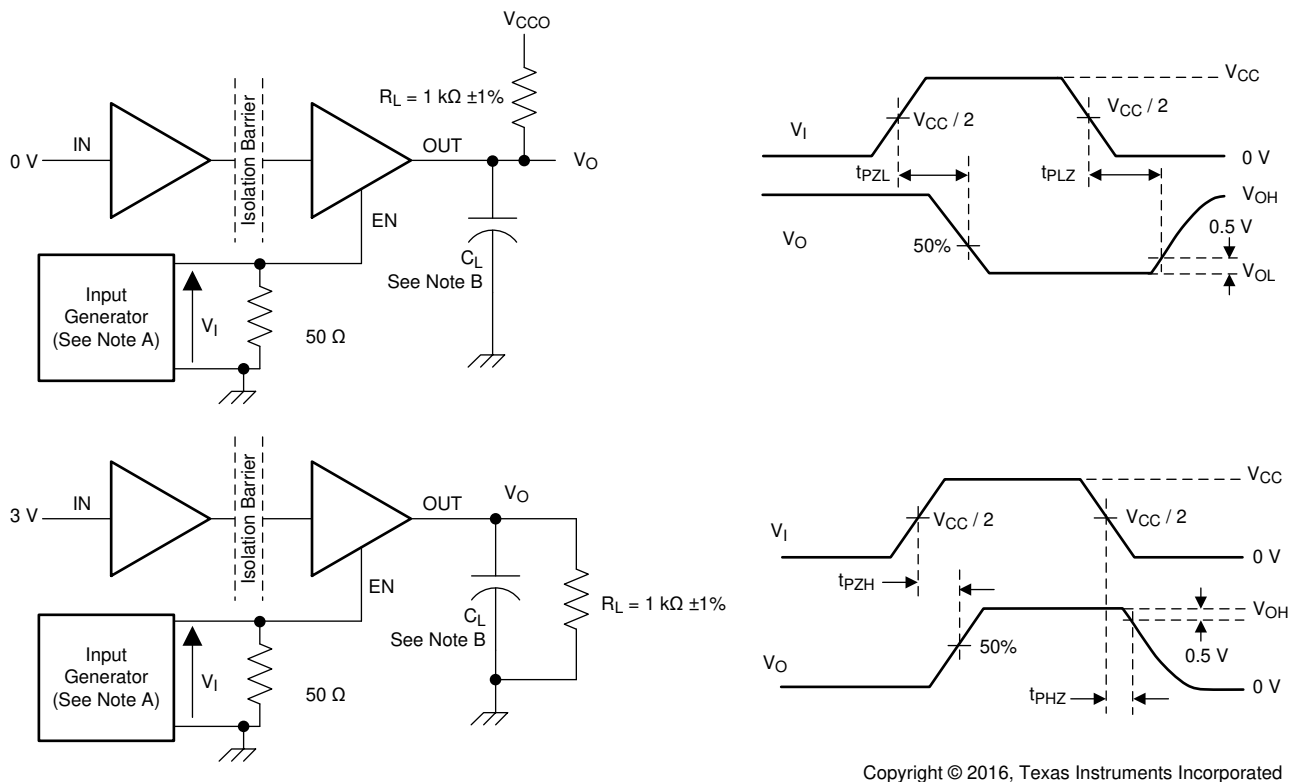
**Figure 6-8. Propagation Delay Time vs Free-Air Temperature**

## 7 Parameter Measurement Information



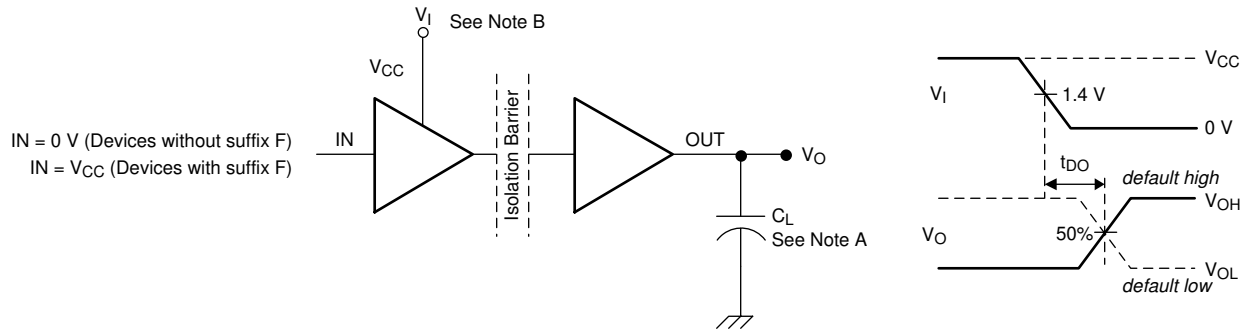
- A. The input pulse is supplied by a generator having the following characteristics: PRR  $\leq$  50 kHz, 50% duty cycle,  $t_r \leq$  3 ns,  $t_f \leq$  3 ns,  $Z_O =$  50  $\Omega$ . At the input, 50  $\Omega$  resistor is required to terminate Input Generator signal. It is not needed in actual application.
- B.  $C_L =$  15 pF and includes instrumentation and fixture capacitance within  $\pm 20\%$ .

**Figure 7-1. Switching Characteristics Test Circuit and Voltage Waveforms**



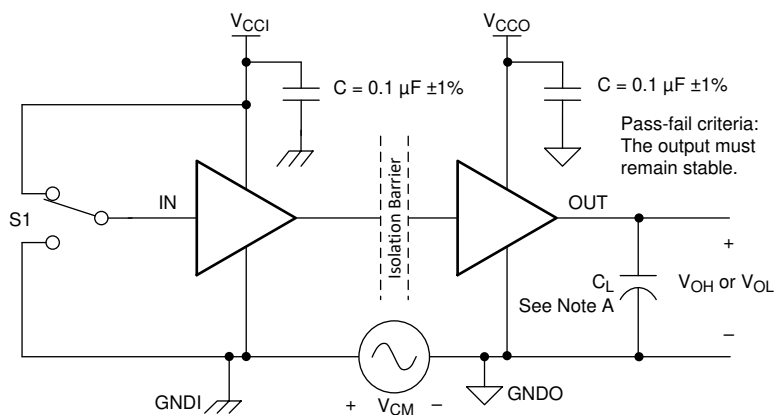
- A. The input pulse is supplied by a generator having the following characteristics: PRR  $\leq$  10 kHz, 50% duty cycle,  $t_r \leq$  3 ns,  $t_f \leq$  3 ns,  $Z_O =$  50  $\Omega$ .
- B.  $C_L =$  15 pF and includes instrumentation and fixture capacitance within  $\pm 20\%$ .

**Figure 7-2. Enable/Disable Propagation Delay Time Test Circuit and Waveform**



- A. C<sub>L</sub> = 15 pF and includes instrumentation and fixture capacitance within ±20%.
- B. Power Supply Ramp Rate = 10 mV/ns

**Figure 7-3. Default Output Delay Time Test Circuit and Voltage Waveforms**



- A. C<sub>L</sub> = 15 pF and includes instrumentation and fixture capacitance within ±20%.

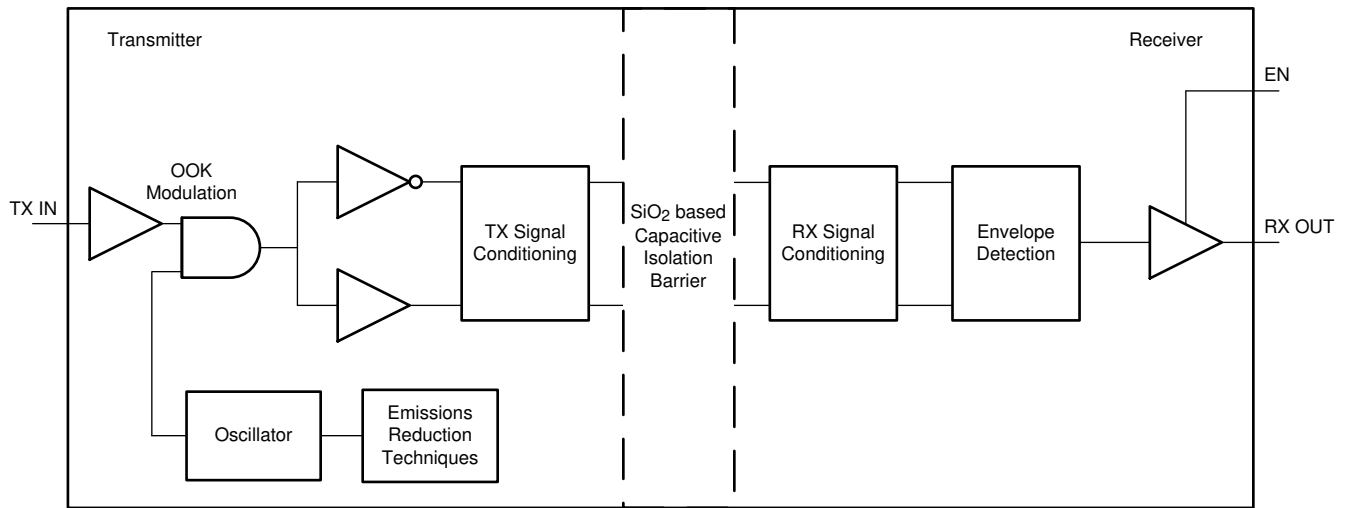
**Figure 7-4. Common-Mode Transient Immunity Test Circuit**

## 8 Detailed Description

### 8.1 Overview

The ISO6731 device has an ON-OFF keying (OOK) modulation scheme to transmit the digital data across a silicon dioxide based isolation barrier. The transmitter sends a high frequency carrier across the barrier to represent one digital state and sends no signal to represent the other digital state. The receiver demodulates the signal after advanced signal conditioning and produces the output through a buffer stage. If the ENx pin is low then the output goes to high impedance. The ISO6731 device also incorporate advanced circuit techniques to maximize the CMTI performance and minimize the radiated emissions due to the high frequency carrier and IO buffer switching. The conceptual block diagram of a digital capacitive isolator, [Figure 8-1](#), shows a functional block diagram of a typical channel.

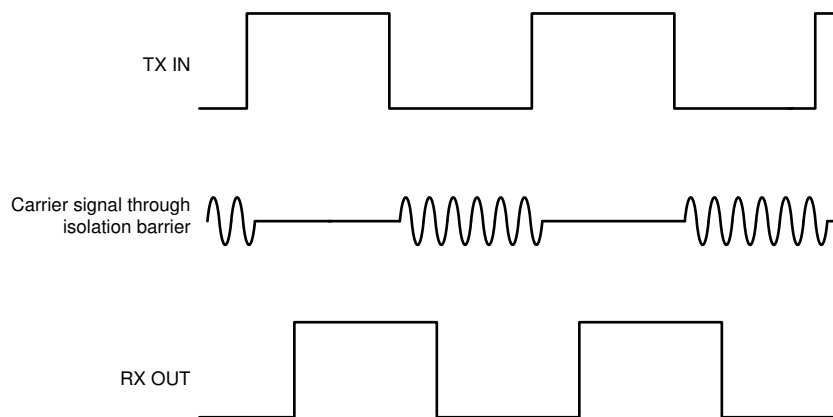
### 8.2 Functional Block Diagram



Copyright © 2016, Texas Instruments Incorporated

**Figure 8-1. Conceptual Block Diagram of a Digital Capacitive Isolator**

[Figure 8-2](#) shows a conceptual detail of how the ON-OFF keying scheme works.



**Figure 8-2. On-Off Keying (OOK) Based Modulation Scheme**

### 8.3 Feature Description

Table 8-1 provides an overview of the device features.

**Table 8-1. Device Features**

PART NUMBER	CHANNEL DIRECTION	MAXIMUM DATA RATE	DEFAULT OUTPUT	PACKAGE	RATED ISOLATION <sup>(1)</sup>
ISO6731	2 Forward, 1 Reverse	50 Mbps	High	DW-16	5000 V <sub>RMS</sub> / 8000 V <sub>PK</sub>
ISO6731F	2 Forward, 1 Reverse	50 Mbps	Low	DW-16	5000 V <sub>RMS</sub> / 8000 V <sub>PK</sub>

(1) See for detailed isolation ratings.

#### 8.3.1 Electromagnetic Compatibility (EMC) Considerations

Many applications in harsh industrial environment are sensitive to disturbances such as electrostatic discharge (ESD), electrical fast transient (EFT), surge and electromagnetic emissions. These electromagnetic disturbances are regulated by international standards such as IEC 61000-4-x and CISPR 22. Although system-level performance and reliability depends, to a large extent, on the application board design and layout, the ISO6731 device incorporates many chip-level design improvements for overall system robustness. Some of these improvements include:

- Robust ESD protection cells for input and output signal pins and inter-chip bond pads.
- Low-resistance connectivity of ESD cells to supply and ground pins.
- Enhanced performance of high voltage isolation capacitor for better tolerance of ESD, EFT and surge events.
- Bigger on-chip decoupling capacitors to bypass undesirable high energy signals through a low impedance path.
- PMOS and NMOS devices isolated from each other by using guard rings to avoid triggering of parasitic SCRs.
- Reduced common mode currents across the isolation barrier by ensuring purely differential internal operation.

## 8.4 Device Functional Modes

Table 8-2 lists the functional modes for the ISO6731 device.

Table 8-2. Function Table

V <sub>CCI</sub> <sup>(1)</sup>	V <sub>CCO</sub>	INPUT (IN <sub>x</sub> ) <sup>(3)</sup>	OUTPUT ENABLE (EN <sub>x</sub> )	OUTPUT (OUT <sub>x</sub> )	COMMENTS
PU	PU	H	H or open	H	Normal Operation: A channel output assumes the logic state of its input.
		L	H or open	L	
		Open	H or open	Default	Default mode: When IN <sub>x</sub> is open, the corresponding channel output goes to its default logic state. Default is <i>High</i> for ISO6731 and <i>Low</i> for ISO6731 with F suffix.
X	PU	X	L	Z	A low value of output enable causes the outputs to be high-impedance.
PD	PU	X	H or open	Default	Default mode: When V <sub>CCI</sub> is unpowered, a channel output assumes the logic state based on the selected default option. Default is <i>High</i> for ISO6731 and <i>Low</i> for ISO6731 with F suffix. When V <sub>CCI</sub> transitions from unpowered to powered-up, a channel output assumes the logic state of the input. When V <sub>CCI</sub> transitions from powered-up to unpowered, channel output assumes the selected default state.
X	PD	X	X	Undetermined	When V <sub>CCO</sub> is unpowered, a channel output is undetermined <sup>(2)</sup> . When V <sub>CCO</sub> transitions from unpowered to powered-up, a channel output assumes the logic state of the input.

- (1) V<sub>CCI</sub> = Input-side V<sub>CC</sub>; V<sub>CCO</sub> = Output-side V<sub>CC</sub>; PU = Powered up (V<sub>CC</sub> ≥ 1.71 V); PD = Powered down (V<sub>CC</sub> ≤ 1.05 V); X = Irrelevant; H = High level; L = Low level; Z = High Impedance  
 (2) The outputs are in undetermined state when 1.89 V < V<sub>CCI</sub>, V<sub>CCO</sub> < 2.25 V and 1.05 V < V<sub>CCI</sub>, V<sub>CCO</sub> < 1.71 V  
 (3) A strongly driven input signal can weakly power the floating V<sub>CC</sub> through an internal protection diode and cause undetermined output

### 8.4.1 Device I/O Schematics

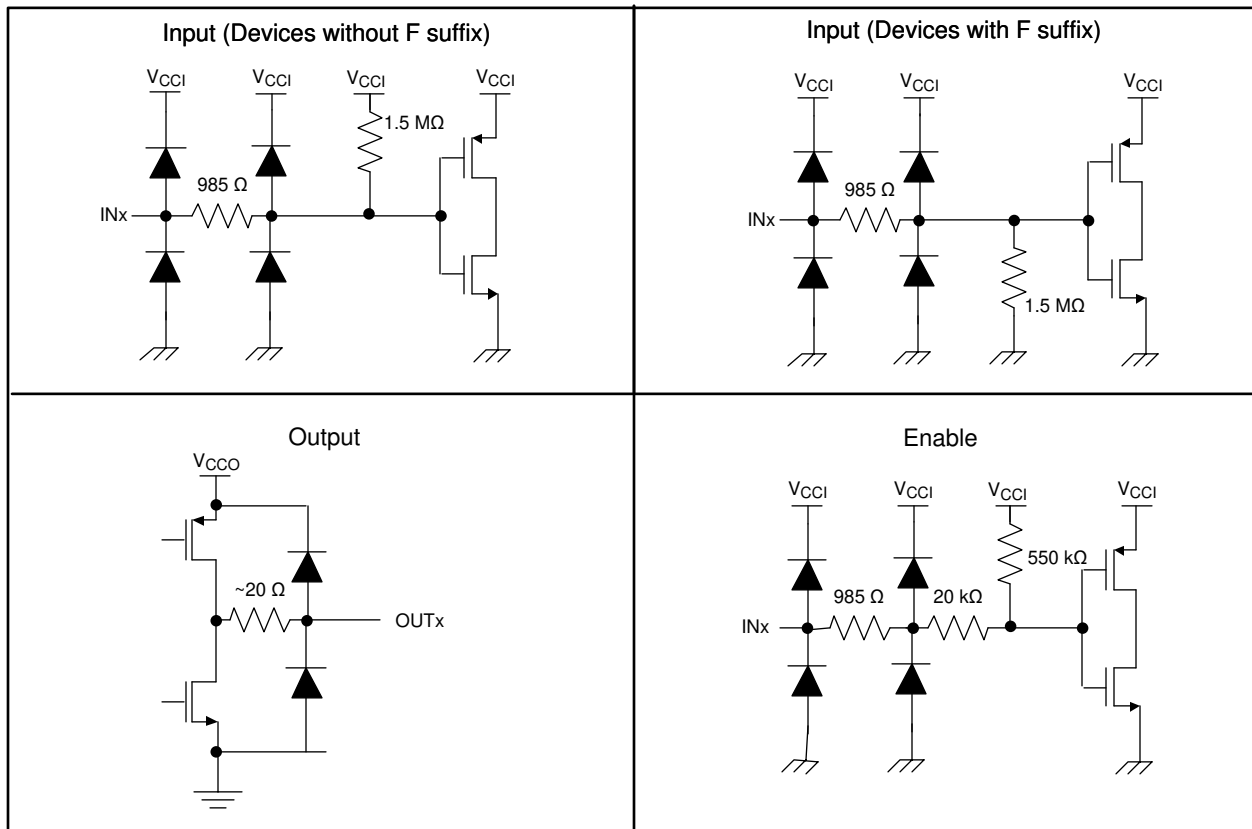


Figure 8-3. Device I/O Schematics

## 9 Application and Implementation

### Note

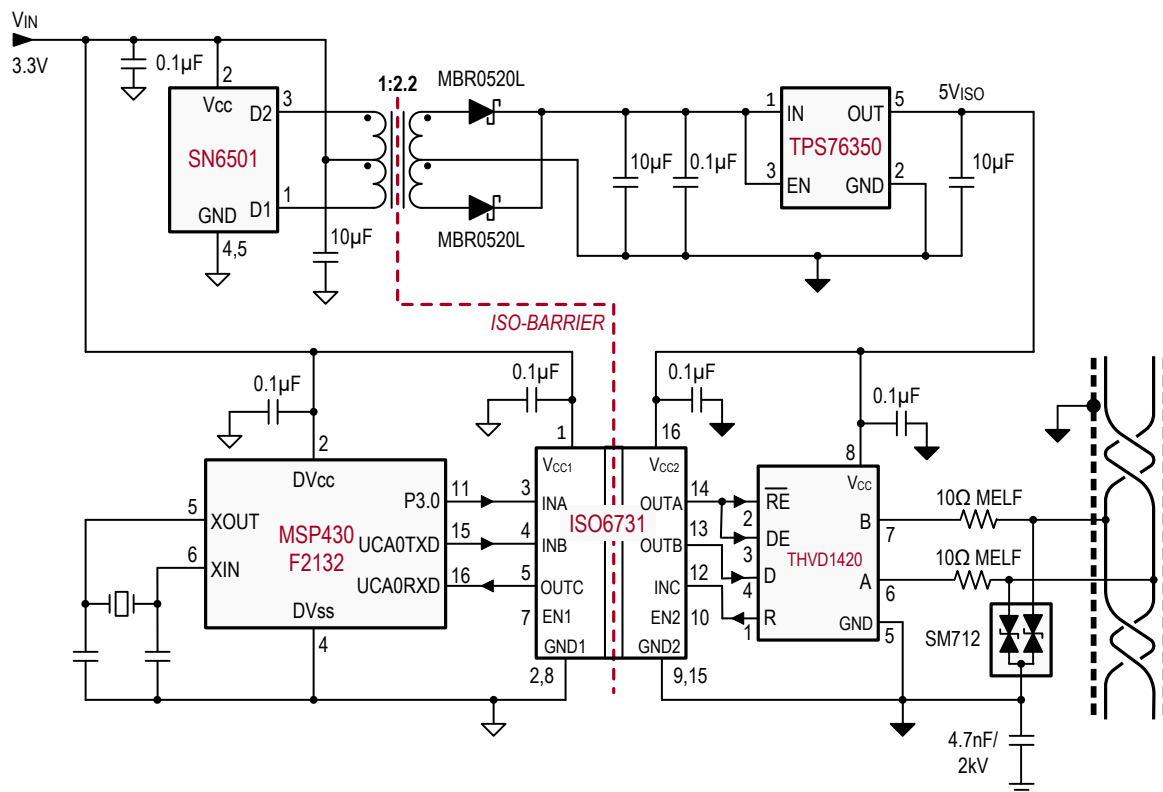
Information in the following applications sections is not part of the TI component specification, and TI does not warrant its accuracy or completeness. TI's customers are responsible for determining suitability of components for their purposes. Customers should validate and test their design implementation to confirm system functionality.

### 9.1 Application Information

The ISO6731 device is a high-performance, triple-channel digital isolators. This device comes with enable pins on each side which can be used to put the respective outputs in high impedance for multi master driving applications. The ISO6731 device uses single-ended CMOS-logic switching technology. The supply voltage range is from 1.71 V to 5.5 V for both supplies,  $V_{CC1}$  and  $V_{CC2}$ . Since an isolation barrier separates the two sides, each side can be sourced independently with any voltage within recommended operating conditions. As an example, it is possible to supply ISO6731  $V_{CC1}$  with 3.3 V (which is within 1.71 V to 5.5 V) and  $V_{CC2}$  with 5V (which is also within 1.71 V to 5.5 V). You can use the digital isolator as a logic-level translator in addition to providing isolation. When designing with digital isolators, keep in mind that because of the single-ended design structure, digital isolators do not conform to any specific interface standard and are only intended for isolating single-ended CMOS or TTL digital signal lines. The isolator is typically placed between the data controller (that is, MCU or FPGA), and a data converter or a line transceiver, regardless of the interface type or standard.

### 9.2 Typical Application

Figure 9-1 shows the ISO6731 device, combined with Texas Instruments' mixed-signal microcontroller, RS-485 transceiver, transformer driver, and voltage regulator, can create an isolated RS-485 system.



Copyright © 2020, Texas Instruments Incorporated

Figure 9-1. Isolated RS-485 Interface Circuit

### 9.2.1 Design Requirements

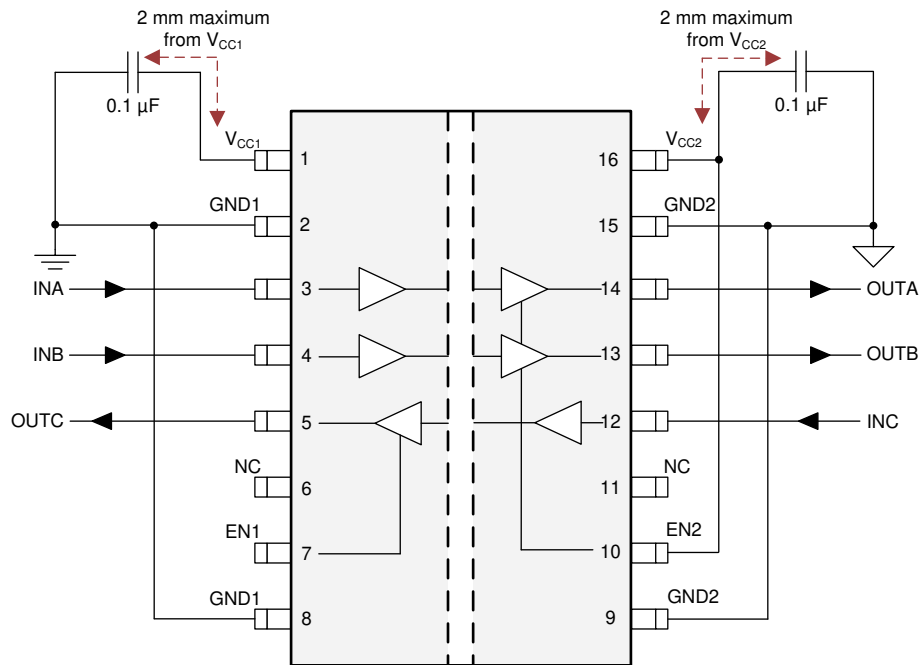
To design with this device, use the parameters listed in [Table 9-1](#).

**Table 9-1. Design Parameters**

PARAMETER	VALUE
Supply voltage, $V_{CC1}$ and $V_{CC2}$	1.71 V to 1.89 V and 2.25 V to 5.5 V
Decoupling capacitor between $V_{CC1}$ and GND1	0.1 $\mu$ F
Decoupling capacitor from $V_{CC2}$ and GND2	0.1 $\mu$ F

### 9.2.2 Detailed Design Procedure

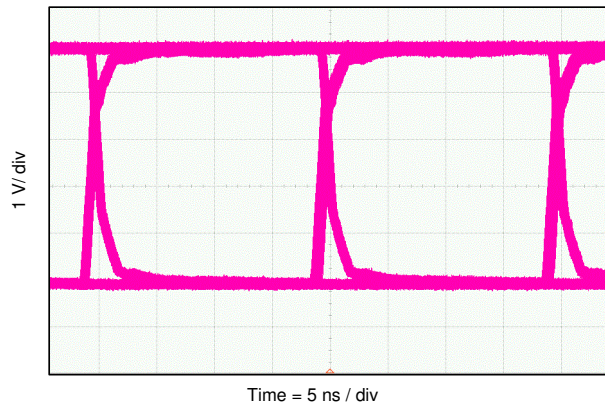
Unlike optocouplers, which require external components to improve performance, provide bias, or limit current, the ISO6731 device only requires two external bypass capacitors to operate.



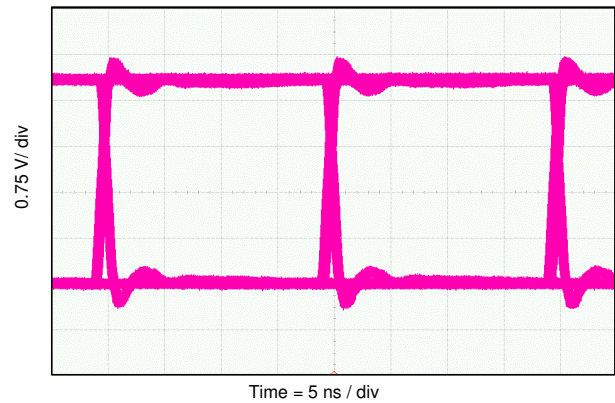
**Figure 9-2. Typical ISO6731 Circuit Hook-up**

### 9.2.3 Application Curve

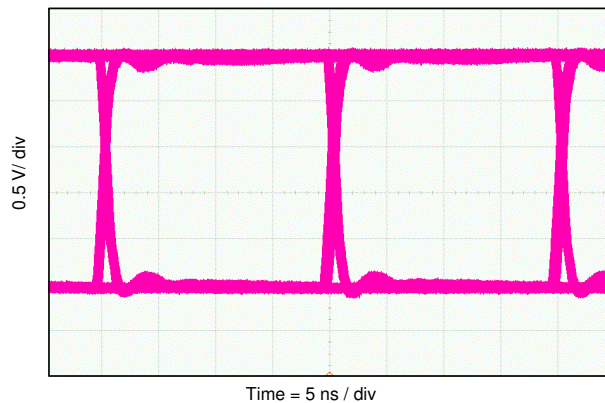
The following typical eye diagrams of the ISO6731 family of devices indicates low jitter and wide open eye at the maximum data rate of 50 Mbps.



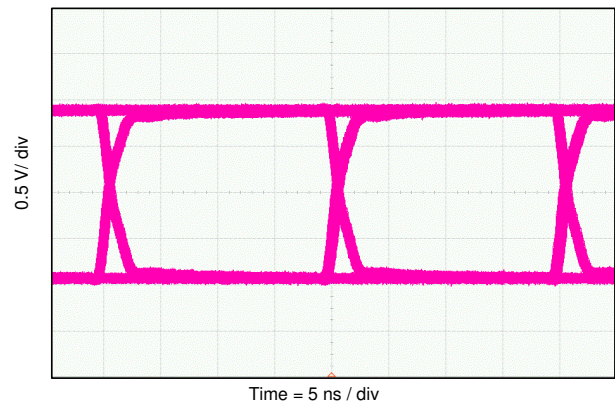
**Figure 9-3. Eye Diagram at 50 Mbps PRBS 2<sup>16</sup> – 1, 5 V and 25°C**



**Figure 9-4. Eye Diagram at 50 Mbps PRBS 2<sup>16</sup> – 1, 3.3 V and 25°C**



**Figure 9-5. Eye Diagram at 50 Mbps PRBS 2<sup>16</sup> – 1, 2.5 V and 25°C**



**Figure 9-6. Eye Diagram at 50 Mbps PRBS 2<sup>16</sup> – 1, 1.8 V and 25°C**

#### 9.2.3.1 Insulation Lifetime

Insulation lifetime projection data is collected by using industry-standard Time Dependent Dielectric Breakdown (TDDB) test method. In this test, all pins on each side of the barrier are tied together creating a two-terminal device and high voltage applied between the two sides; See [Figure 9-7](#) for TDDB test setup. The insulation breakdown data is collected at various high voltages switching at 60 Hz over temperature. For reinforced insulation, VDE standard requires the use of TDDB projection line with failure rate of less than 1 part per million (ppm). Even though the expected minimum insulation lifetime is 20 years at the specified working isolation voltage, VDE reinforced certification requires additional safety margin of 20% for working voltage and 50% for lifetime which translates into minimum required insulation lifetime of 30 years at a working voltage that's 20% higher than the specified value.

[Figure 9-8](#) shows the intrinsic capability of the isolation barrier to withstand high voltage stress over its lifetime. Based on the TDDB data, the intrinsic capability of the insulation is 1500 V<sub>RMS</sub> with a lifetime of 36 years. Other factors, such as package size, pollution degree, material group, etc. can further limit the working voltage of the component. The working voltage of DW-16 package is specified upto 1500 V<sub>RMS</sub>. At the lower working voltages, the corresponding insulation lifetime is much longer than 36 years.

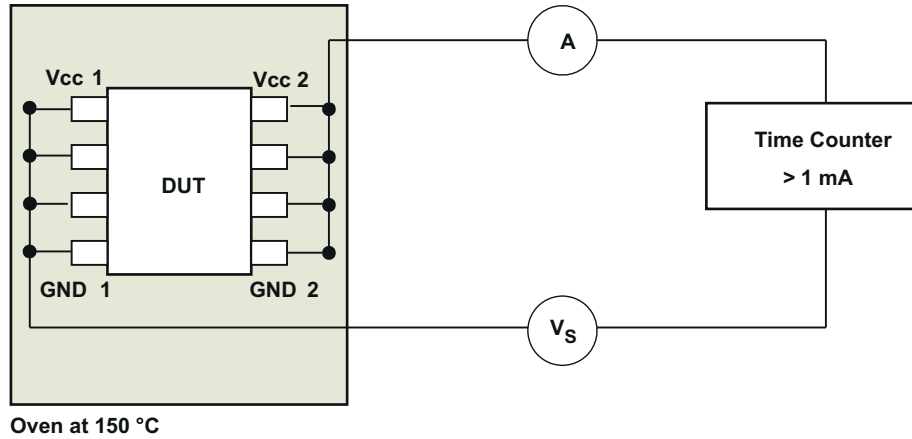


Figure 9-7. Test Setup for Insulation Lifetime Measurement

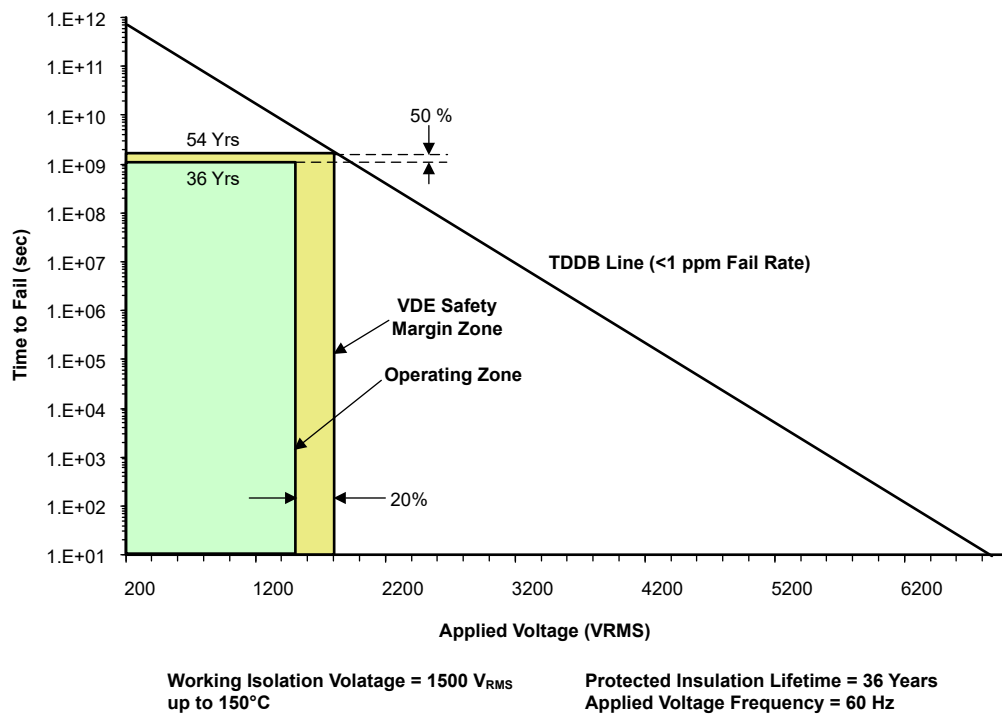


Figure 9-8. Insulation Lifetime Projection Data

## 10 Power Supply Recommendations

Power Supply Recommendation update with SN6505B (previously SN6505A)

To help ensure reliable operation at data rates and supply voltages, a 0.1- $\mu$ F bypass capacitor is recommended at the input and output supply pins ( $V_{CC1}$  and  $V_{CC2}$ ). The capacitors should be placed as close to the supply pins as possible. If only a single primary-side power supply is available in an application, isolated power can be generated for the secondary-side with the help of a transformer driver. For industrial applications, please use Texas Instruments' [SN6501](#) or [SN6505B](#). For such applications, detailed power supply design and transformer selection recommendations are available in [SN6501 Transformer Driver for Isolated Power Supplies](#) or [SN6505B-Q1 Low-noise, 1-A Transformer Drivers for Isolated Power Supplies](#)

## 11 Layout

### 11.1 Layout Guidelines

A minimum of two layers is required to accomplish a cost optimized and low EMI PCB design. To further improve EMI, a four layer board can be used (see [Figure 11-2](#)). Layer stacking should be in the following order (top-to-bottom): high-speed signal layer, ground plane, power plane and low-frequency signal layer.

- Routing the high-speed traces on the top layer avoids the use of vias (and the introduction of their inductances) and allows for clean interconnects between the isolator and the transmitter and receiver circuits of the data link.
- Placing a solid ground plane next to the high-speed signal layer establishes controlled impedance for transmission line interconnects and provides an excellent low-inductance path for the return current flow.
- Placing the power plane next to the ground plane creates additional high-frequency bypass capacitance of approximately 100 pF/inch<sup>2</sup>.
- Routing the slower speed control signals on the bottom layer allows for greater flexibility as these signal links usually have margin to tolerate discontinuities such as vias.

If an additional supply voltage plane or signal layer is needed, add a second power or ground plane system to the stack to keep it symmetrical. This makes the stack mechanically stable and prevents it from warping. Also the power and ground plane of each power system can be placed closer together, thus increasing the high-frequency bypass capacitance significantly.

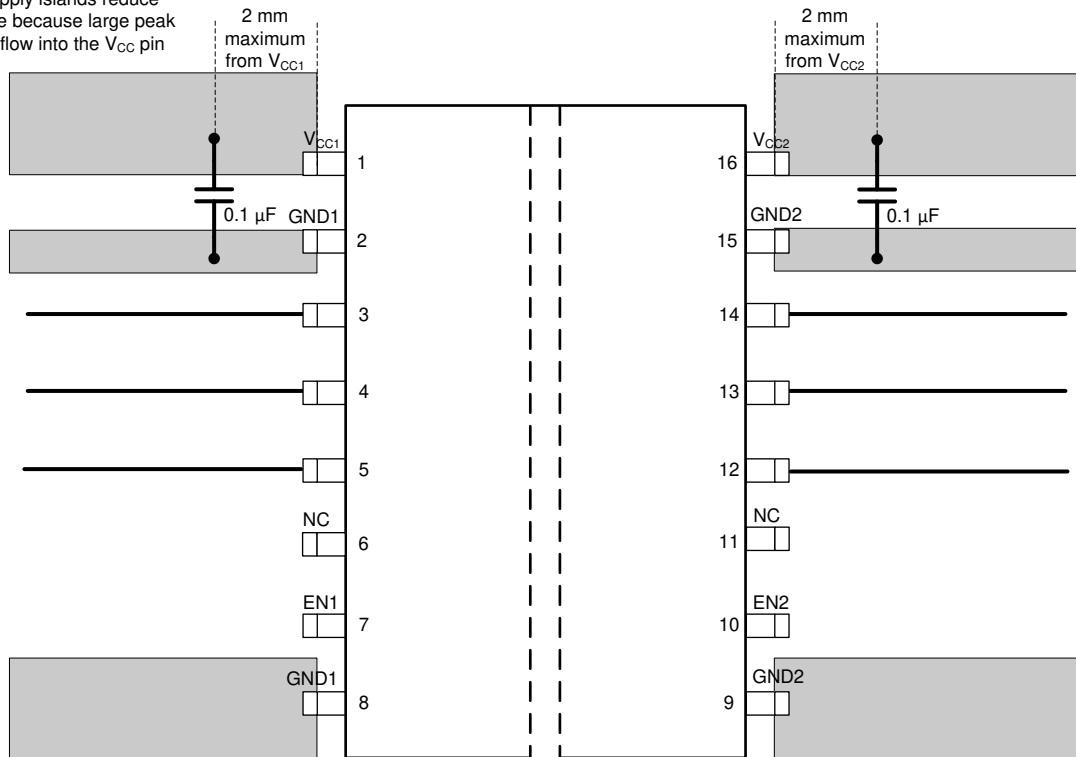
For detailed layout recommendations, refer to the [Digital Isolator Design Guide](#).

#### 11.1.1 PCB Material

For digital circuit boards operating below 150 Mbps, (or rise and fall times higher than 1 ns), and trace lengths of up to 10 inches, use standard FR-4 UL94V-0 printed circuit boards. This PCB is preferred over cheaper alternatives due to its lower dielectric losses at high frequencies, less moisture absorption, greater strength and stiffness, and self-extinguishing flammability-characteristics.

## 11.2 Layout Example

Solid supply islands reduce inductance because large peak currents flow into the  $V_{CC}$  pin



Solid ground islands help dissipate heat through PCB

Figure 11-1. Layout Example

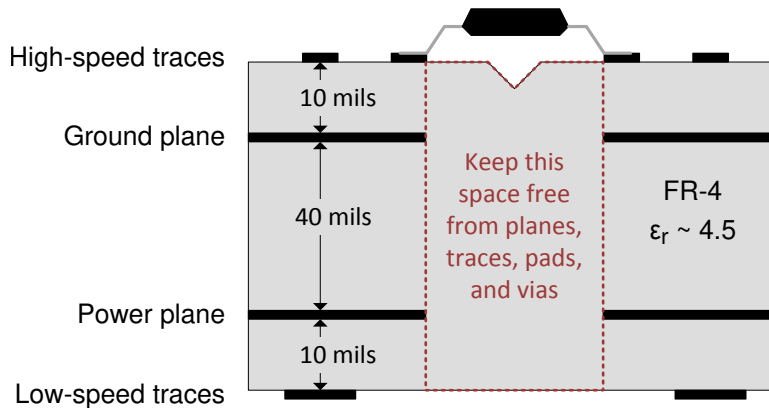


Figure 11-2. Layout Example Schematic

## 12 Device and Documentation Support

### 12.1 Documentation Support

#### 12.1.1 Related Documentation

For related documentation, see the following:

- Texas Instruments, [Digital Isolator Design Guide](#)
- Texas Instruments, [ADS79xx 12/10/8-Bit, 1 MSPS, 16/12/8/4-Channel, Single-Ended, MicroPower, Serial Interface ADCs data sheet](#)
- Texas Instruments, [Isolation Glossary](#)
- Texas Instruments, [Top 6 Design Questions about I<sup>2</sup>C isolators](#)
- Texas Instruments, [Designing a reinforced isolated I<sup>2</sup>C-Bus interface by using digital isolators](#)
- Texas Instruments, [How to isolate signal and power for I<sup>2</sup>C interfaces](#)
- Texas Instruments, [How to use isolation to improve ESD, EFT, and Surge immunity in industrial systems application report](#)
- Texas Instruments, [DAC161P997 Single-Wire 16-bit DAC for 4- to 20-mA Loops data sheet](#)
- Texas Instruments, [MSP430G2132 Mixed Signal Microcontroller data sheet](#)
- Texas Instruments, [SN6501 Transformer Driver for Isolated Power Supplies data sheet](#)
- Texas Instruments, [TPS76333 Low-Power 150-mA Low-Dropout Linear Regulators data sheet](#)

#### 12.2 Receiving Notification of Documentation Updates

To receive notification of documentation updates, navigate to the device product folder on ti.com. In the upper right corner, click on *Alert me* to register and receive a weekly digest of any product information that has changed. For change details, review the revision history included in any revised document.

#### 12.3 Support Resources

TI E2E™ [support forums](#) are an engineer's go-to source for fast, verified answers and design help — straight from the experts. Search existing answers or ask your own question to get the quick design help you need.

Linked content is provided "AS IS" by the respective contributors. They do not constitute TI specifications and do not necessarily reflect TI's views; see TI's [Terms of Use](#).

#### 12.4 Trademarks

TI E2E™ is a trademark of Texas Instruments.

All trademarks are the property of their respective owners.

#### 12.5 Electrostatic Discharge Caution



This integrated circuit can be damaged by ESD. Texas Instruments recommends that all integrated circuits be handled with appropriate precautions. Failure to observe proper handling and installation procedures can cause damage.

ESD damage can range from subtle performance degradation to complete device failure. Precision integrated circuits may be more susceptible to damage because very small parametric changes could cause the device not to meet its published specifications.

#### 12.6 Glossary

[TI Glossary](#) This glossary lists and explains terms, acronyms, and definitions.

## 13 Mechanical, Packaging, and Orderable Information

The following pages include mechanical packaging and orderable information. This information is the most current data available for the designated device. This data is subject to change without notice and revision of this document. For browser-based versions of this data sheet, refer to the left-hand navigation.

**PACKAGING INFORMATION**

Orderable part number	Status (1)	Material type (2)	Package   Pins	Package qty   Carrier	RoHS (3)	Lead finish/ Ball material (4)	MSL rating/ Peak reflow (5)	Op temp (°C)	Part marking (6)
<a href="#">ISO6731DWR</a>	Active	Production	SOIC (DW)   16	2000   LARGE T&R	Yes	NIPDAU	Level-2-260C-1 YEAR	-40 to 125	ISO6731
ISO6731DWR.A	Active	Production	SOIC (DW)   16	2000   LARGE T&R	Yes	NIPDAU	Level-2-260C-1 YEAR	-40 to 125	ISO6731
ISO6731DWR.B	Active	Production	SOIC (DW)   16	2000   LARGE T&R	-	Call TI	Call TI	-40 to 125	
<a href="#">ISO6731FDWR</a>	Active	Production	SOIC (DW)   16	2000   LARGE T&R	Yes	NIPDAU	Level-2-260C-1 YEAR	-40 to 125	ISO6731F
ISO6731FDWR.A	Active	Production	SOIC (DW)   16	2000   LARGE T&R	Yes	NIPDAU	Level-2-260C-1 YEAR	-40 to 125	ISO6731F
ISO6731FDWR.B	Active	Production	SOIC (DW)   16	2000   LARGE T&R	-	Call TI	Call TI	-40 to 125	

(1) **Status:** For more details on status, see our [product life cycle](#).

(2) **Material type:** When designated, preproduction parts are prototypes/experimental devices, and are not yet approved or released for full production. Testing and final process, including without limitation quality assurance, reliability performance testing, and/or process qualification, may not yet be complete, and this item is subject to further changes or possible discontinuation. If available for ordering, purchases will be subject to an additional waiver at checkout, and are intended for early internal evaluation purposes only. These items are sold without warranties of any kind.

(3) **RoHS values:** Yes, No, RoHS Exempt. See the [TI RoHS Statement](#) for additional information and value definition.

(4) **Lead finish/Ball material:** Parts may have multiple material finish options. Finish options are separated by a vertical ruled line. Lead finish/Ball material values may wrap to two lines if the finish value exceeds the maximum column width.

(5) **MSL rating/Peak reflow:** The moisture sensitivity level ratings and peak solder (reflow) temperatures. In the event that a part has multiple moisture sensitivity ratings, only the lowest level per JEDEC standards is shown. Refer to the shipping label for the actual reflow temperature that will be used to mount the part to the printed circuit board.

(6) **Part marking:** There may be an additional marking, which relates to the logo, the lot trace code information, or the environmental category of the part.

Multiple part markings will be inside parentheses. Only one part marking contained in parentheses and separated by a "~" will appear on a part. If a line is indented then it is a continuation of the previous line and the two combined represent the entire part marking for that device.

**Important Information and Disclaimer:**The information provided on this page represents TI's knowledge and belief as of the date that it is provided. TI bases its knowledge and belief on information provided by third parties, and makes no representation or warranty as to the accuracy of such information. Efforts are underway to better integrate information from third parties. TI has taken and continues to take reasonable steps to provide representative and accurate information but may not have conducted destructive testing or chemical analysis on incoming materials and chemicals. TI and TI suppliers consider certain information to be proprietary, and thus CAS numbers and other limited information may not be available for release.

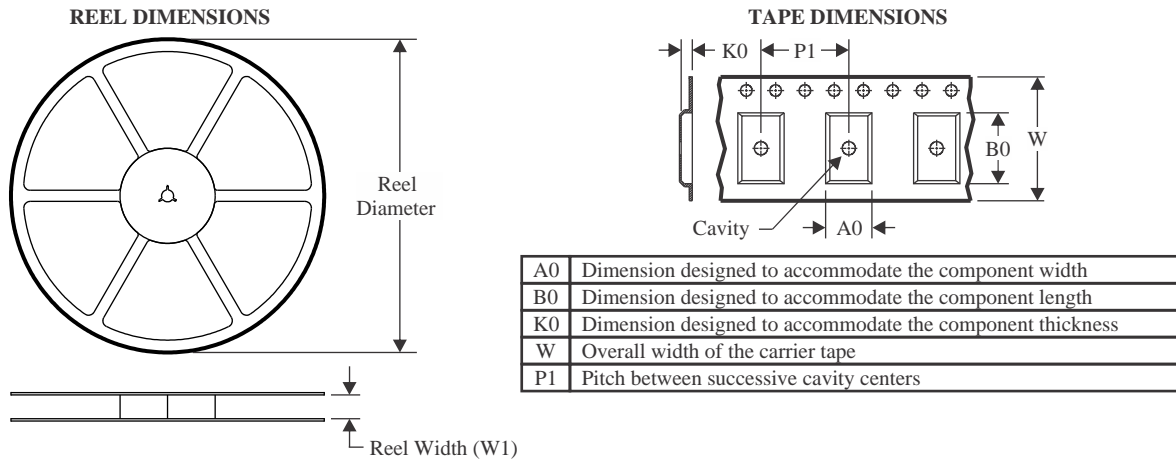
In no event shall TI's liability arising out of such information exceed the total purchase price of the TI part(s) at issue in this document sold by TI to Customer on an annual basis.

**OTHER QUALIFIED VERSIONS OF ISO6731 :**

- Automotive : [ISO6731-Q1](#)

## NOTE: Qualified Version Definitions:

- Automotive - Q100 devices qualified for high-reliability automotive applications targeting zero defects

**TAPE AND REEL INFORMATION**

**QUADRANT ASSIGNMENTS FOR PIN 1 ORIENTATION IN TAPE**


\*All dimensions are nominal

Device	Package Type	Package Drawing	Pins	SPQ	Reel Diameter (mm)	Reel Width W1 (mm)	A0 (mm)	B0 (mm)	K0 (mm)	P1 (mm)	W (mm)	Pin1 Quadrant
ISO6731DWR	SOIC	DW	16	2000	330.0	16.4	10.75	10.7	2.7	12.0	16.0	Q1
ISO6731FDWR	SOIC	DW	16	2000	330.0	16.4	10.75	10.7	2.7	12.0	16.0	Q1

**TAPE AND REEL BOX DIMENSIONS**


\*All dimensions are nominal

Device	Package Type	Package Drawing	Pins	SPQ	Length (mm)	Width (mm)	Height (mm)
ISO6731DWR	SOIC	DW	16	2000	353.0	353.0	32.0
ISO6731FDWR	SOIC	DW	16	2000	353.0	353.0	32.0

## GENERIC PACKAGE VIEW

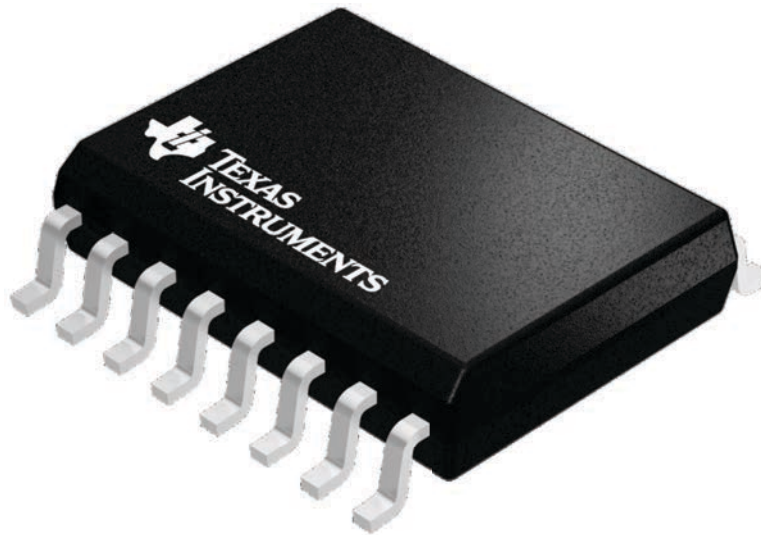
**DW 16**

**SOIC - 2.65 mm max height**

7.5 x 10.3, 1.27 mm pitch

SMALL OUTLINE INTEGRATED CIRCUIT

This image is a representation of the package family, actual package may vary.  
Refer to the product data sheet for package details.



4224780/A

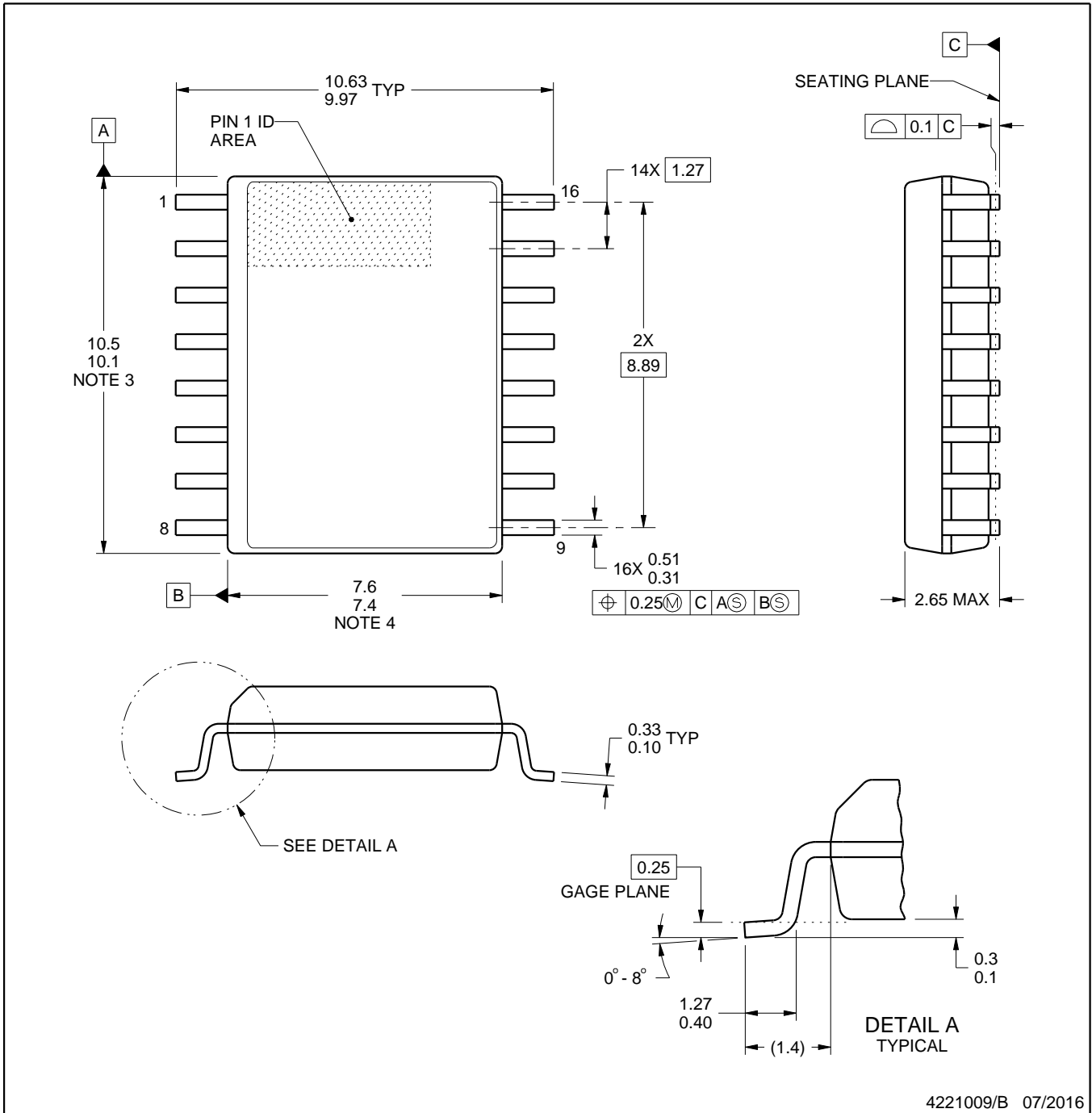


# DW0016B

# PACKAGE OUTLINE

## SOIC - 2.65 mm max height

SOIC



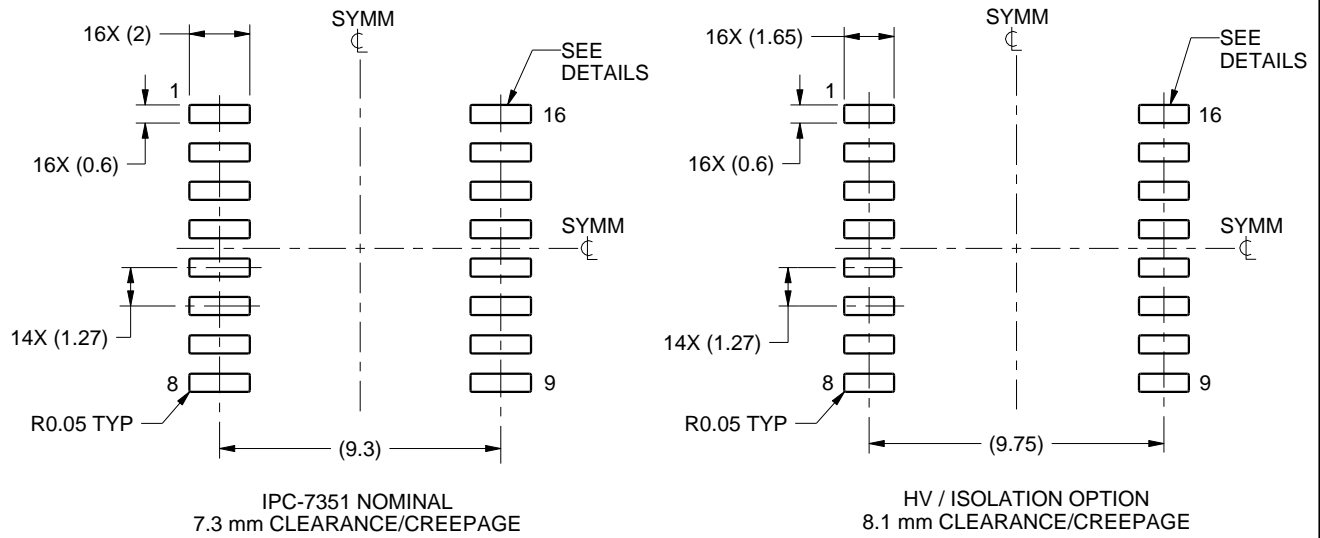
4221009/B 07/2016

# EXAMPLE BOARD LAYOUT

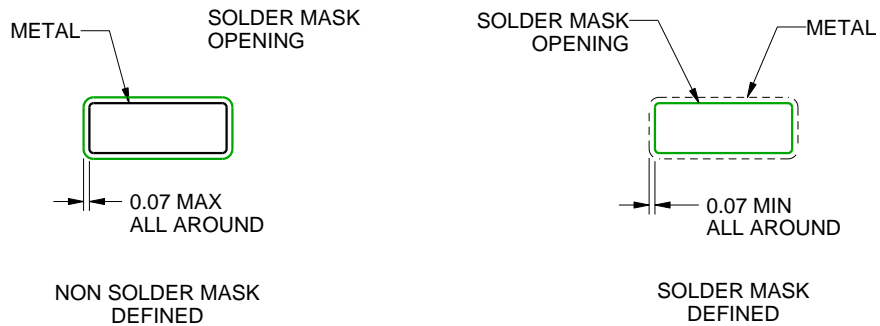
DW0016B

SOIC - 2.65 mm max height

SOIC



LAND PATTERN EXAMPLE  
SCALE:4X



SOLDER MASK DETAILS

4221009/B 07/2016

NOTES: (continued)

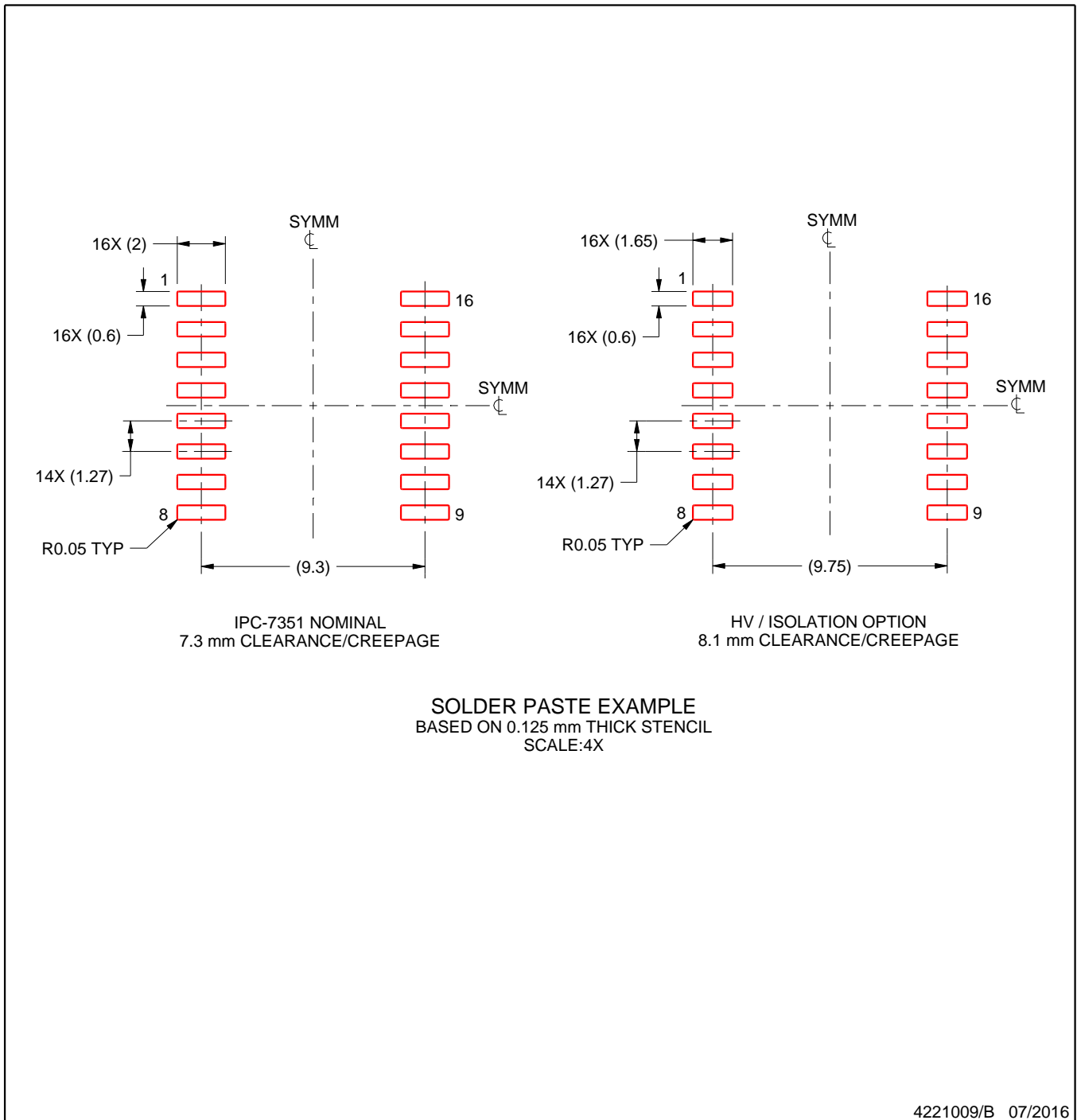
- 6. Publication IPC-7351 may have alternate designs.
- 7. Solder mask tolerances between and around signal pads can vary based on board fabrication site.

# EXAMPLE STENCIL DESIGN

DW0016B

SOIC - 2.65 mm max height

SOIC



NOTES: (continued)

8. Laser cutting apertures with trapezoidal walls and rounded corners may offer better paste release. IPC-7525 may have alternate design recommendations.
9. Board assembly site may have different recommendations for stencil design.

## IMPORTANT NOTICE AND DISCLAIMER

TI PROVIDES TECHNICAL AND RELIABILITY DATA (INCLUDING DATASHEETS), DESIGN RESOURCES (INCLUDING REFERENCE DESIGNS), APPLICATION OR OTHER DESIGN ADVICE, WEB TOOLS, SAFETY INFORMATION, AND OTHER RESOURCES "AS IS" AND WITH ALL FAULTS, AND DISCLAIMS ALL WARRANTIES, EXPRESS AND IMPLIED, INCLUDING WITHOUT LIMITATION ANY IMPLIED WARRANTIES OF MERCHANTABILITY, FITNESS FOR A PARTICULAR PURPOSE OR NON-INFRINGEMENT OF THIRD PARTY INTELLECTUAL PROPERTY RIGHTS.

These resources are intended for skilled developers designing with TI products. You are solely responsible for (1) selecting the appropriate TI products for your application, (2) designing, validating and testing your application, and (3) ensuring your application meets applicable standards, and any other safety, security, regulatory or other requirements.

These resources are subject to change without notice. TI grants you permission to use these resources only for development of an application that uses the TI products described in the resource. Other reproduction and display of these resources is prohibited. No license is granted to any other TI intellectual property right or to any third party intellectual property right. TI disclaims responsibility for, and you fully indemnify TI and its representatives against any claims, damages, costs, losses, and liabilities arising out of your use of these resources.

TI's products are provided subject to [TI's Terms of Sale](#), [TI's General Quality Guidelines](#), or other applicable terms available either on [ti.com](http://ti.com) or provided in conjunction with such TI products. TI's provision of these resources does not expand or otherwise alter TI's applicable warranties or warranty disclaimers for TI products. Unless TI explicitly designates a product as custom or customer-specified, TI products are standard, catalog, general purpose devices.

TI objects to and rejects any additional or different terms you may propose.

Copyright © 2025, Texas Instruments Incorporated

Last updated 10/2025

## Looking for pricing, stock, or lifecycle information?

Click below to explore more details on WIN SOURCE:

 [View ISO6731FDWR](#) on WIN SOURCE

 [Texas Instruments](#) Information

## Optimize Your Supply Chain with WIN SOURCE Solutions

-  Global Sourcing Solution
-  Obsolete Management
-  Cost Control Management
-  Shortage Management
-  Alternative Solution
-  Excess Inventory Management