

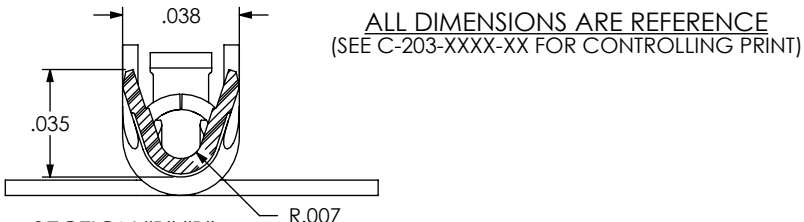

**THE DATASHEET OF
CC03R-2830-01-GF**



DO NOT SCALE FROM THIS PRINT



ALL DIMENSIONS ARE REFERENCE
(SEE C-203-XXXX-XX FOR CONTROLLING PRINT)

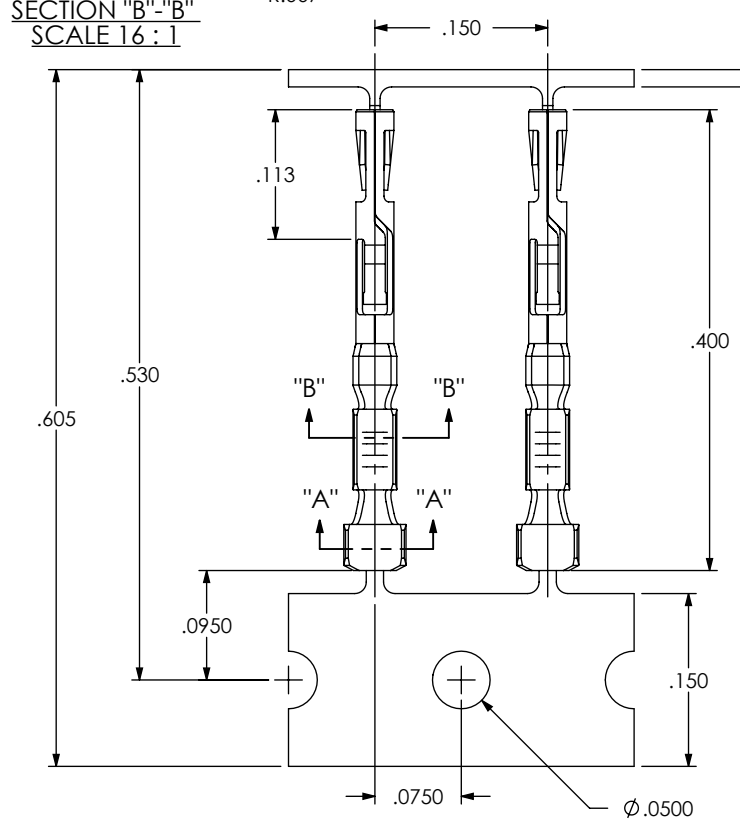

- NOTES:
1. PLATED C-203 PARTS TO BE PULLED, PLATING OPTION CONFIRMED. POSITIONED AS SHOWN ON SAMTEC REEL WITH VIEWPORTS, LABELED CC03R WITH APPROPRIATE PLATING CALLOUT AND LABEL PLACED AS SHOWN.
 2. MAXIMUM NO OF SPLICES PER REEL:
-R: 2
-M: 1
 3. SPLICES ARE NOT TO BE CONNECTED.
 4. NUMBER OF SPLICES TO BE MARKED ON EACH REEL.
 5. REELED PARTS TO BE INTERLEAVED WITH PAPER BETWEEN EACH LAYER OF PARTS.
 6. ALLOWABLE INTERLEAF SPLICES PER REEL:
-R: 3
-M: 1
 7. SECURELY CONNECT INTERLEAF SPLICE.
 8. OUTER WRAP FOR PROTECTIVE REEL BAND AS BELOW:
-R: RB-24-0.75-P
-M: CRT-016-0.018
 9. DUE TO PLATING REQUIREMENTS CONTACT SAMPLES MAY BE REMOVED INTERMITTINGLY FROM THE CARRIER RESULTING IN SMALL GAPS BUT DOES NOT AFFECT FINAL COUNT.
 10. QTY PER REEL:
-R: 35,000 +700/-0 PCS
-M: 1,000 - 5,000 +300/-0 PCS

CC03X-XXXX-01-XX

SUPPLIED
*L: LOOSE
R: REEL
M: MINI REEL (1K -5K CONTACTS)
(* =FOR EXISTING CUSTOMERS ONLY)

PLATING SPECIFICATION
-GF: 3μ" GOLD FLASH IN CONTACT AREA,
3μ" GOLD ON TAIL
-G: 10μ" LIGHT GOLD IN CONTACT AREA,
3μ" GOLD ON TAIL
-H: 30μ" HEAVY GOLD IN CONTACT AREA,
3μ" GOLD ON TAIL

LEAD STYLE
-2830: 28-30 AWG

OPTION INSULATION THICKNESS:

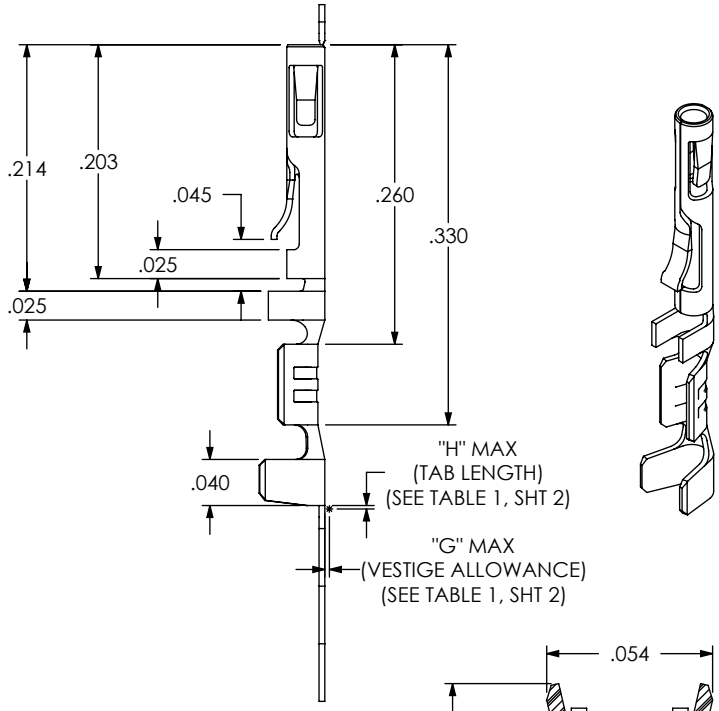
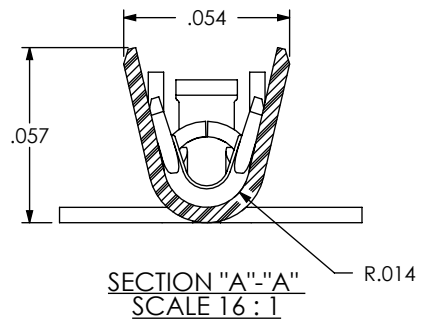
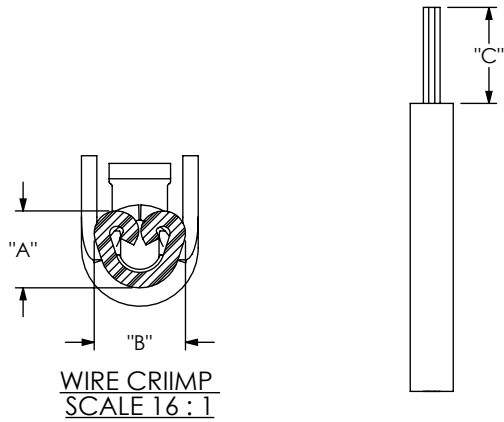

FIG 1
(CC03X-2830-01-X SHOWN)



UNLESS OTHERWISE SPECIFIED, DIMENSIONS ARE IN INCHES. TOLERANCES ARE: DECIMALS ANGLES		<p>PROPRIETARY NOTE</p> <p>* THIS DOCUMENT CONTAINS CONFIDENTIAL AND PROPRIETARY INFORMATION AND ALL DESIGN, MANUFACTURING, REPRODUCTION, USE, PATENT RIGHTS AND SALES RIGHTS ARE EXPRESSLY RESERVED BY SAMTEC, INC. THIS DOCUMENT SHALL NOT BE DISCLOSED, IN WHOLE OR PART, TO ANY UNAUTHORIZED PERSON OR ENTITY NOR REPRODUCED, TRANSFERRED OR INCORPORATED IN ANY OTHER PROJECT IN ANY MANNER WITHOUT THE EXPRESS WRITTEN CONSENT OF SAMTEC, INC.</p>	<p>520 PARK EAST BLVD. NEW ALBANY, IN 47150 PHONE: 812-944-6733 FAX: 812-948-5047 e-Mail: info@SAMTEC.com code: 55322</p>
MATERIAL: DO NOT SCALE DRAWING SHEET SCALE: 6:1	DESCRIPTION: .050" C.L. DISCRETE WIRE CONTACT	DWG. NO. CC03X-XXXX-01-XX	
THICKNESS: .0050	BY: BRATCHER 3/8/2005	SHEET 1 OF 2	



INSULATION STRIP LENGTH

P/N	AWG	STRANDS/AWG	INSULATION OD	"A"	"B"	"C"	"G" MAX (VESTIGE LENGTH)	"H" MAX (TAB LENGTH)	PULL FORCE (LBS)
CC03X-2830-01-XX	30	7/38	.0290-.0380	0.0170	0.0300	0.105	0.08	0.02	2
	28	7/36		0.0180	0.0300		0.08	0.02	1.5

FIG 2
RECOMENDED PROCESSING

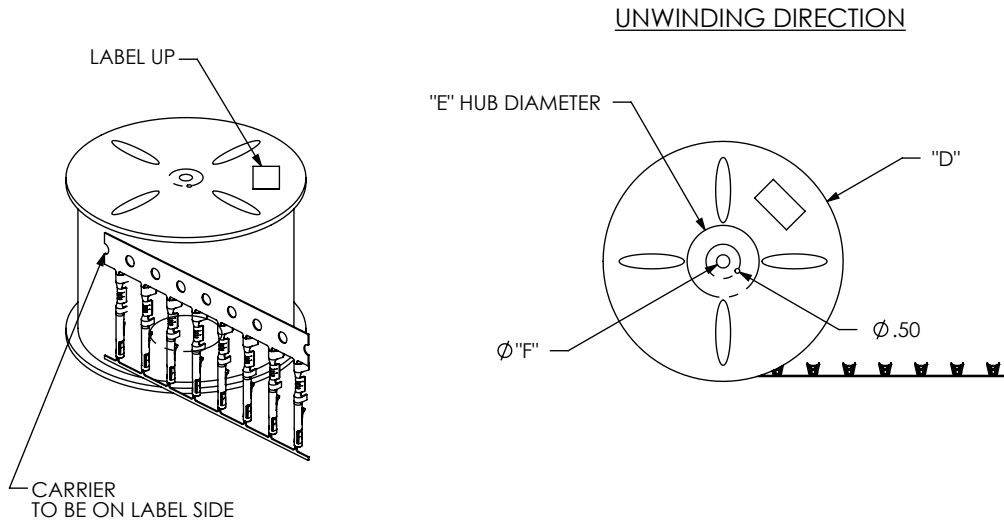



FIG 3
REEL SPECIFICATIONS

SUPPLIED	REEL PART NUMBER	"D"	"E"	"F"
-R	R-24-05.00-0.75-P	24.0	5.50	1.125
-M	MR-13.0-4.00-16	13.0	4.00	0.500

<p>PROPRIETARY NOTE</p> <p>THIS DOCUMENT CONTAINS CONFIDENTIAL AND PROPRIETARY INFORMATION AND ALL DESIGN, MANUFACTURING, REPRODUCTION, USE, PATENT RIGHTS AND SALES RIGHTS ARE EXPRESSLY RESERVED BY SAMTEC, INC. THIS DOCUMENT SHALL NOT BE DISCLOSED, IN WHOLE OR PART, TO ANY UNAUTHORIZED PERSON OR ENTITY NOR REPRODUCED, TRANSFERRED OR INCORPORATED IN ANY OTHER PROJECT IN ANY MANNER WITHOUT THE EXPRESS WRITTEN CONSENT OF SAMTEC, INC.</p> <p>DO NOT SCALE DRAWING</p> <p>SHEET SCALE: 6:1</p>		
	<p>520 PARK EAST BLVD, NEW ALBANY, IN 47150 PHONE: 812-944-6733 FAX: 812-948-5047 e-Mail: info@SAMTEC.com code: 55322</p>	
	<p>DESCRIPTION: .050" C.L. DISCRETE WIRE CONTACT</p>	
	<p>DWG. NO. CC03X-XXXX-01-XX</p>	
<p>BY: BRATCHER 3/8/2005</p>		<p>SHEET 2 OF 2</p>

Looking for pricing, stock, or lifecycle information?

Click below to explore more details on WIN SOURCE:

 [View CC03R-2830-01-GF on WIN SOURCE](#)

 [Samtec Inc. Information](#)

Optimize Your Supply Chain with WIN SOURCE Solutions

-  Global Sourcing Solution
-  Obsolete Management
-  Cost Control Management
-  Shortage Management
-  Alternative Solution
-  Excess Inventory Management