



**THE DATASHEET OF
2220YA250471KJTSYX**



AEC-Q200 MLCC Ranges

A range of dc rated multi-layer chip capacitors from 0.5pF to 4.7µF and in case sizes 0603 to 3640 in COG/NP0 and X7R dielectrics. MLC capacitors and surface mount EMI filters qualified to AEC-Q200 rev E. Approved ranges up to a voltage rating of 6kV to meet the requirements of modern automotive applications including EV and HEV. All parts can incorporate either base metal or precious metal electrodes as an option.

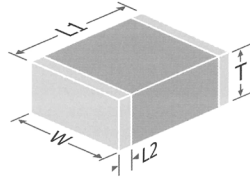

Electrical Details		
Capacitance Range	0.5pF to 4.7µF	
Temperature Coefficient of Capacitance (TCC)	COG/NP0	0 ± 30ppm/°C
	X7R	±15% from -55°C to +125°C
Dissipation Factor	COG/NP0	Cr > 50pF ≤ 0.0015 Cr ≤ 50pF = 0.0015(15÷Cr+0.7)
	Low Loss	≤ 0.001
	X7R	≤ 0.025
Insulation Resistance (IR)	100GΩ or 1000secs (whichever is the less)	
Dielectric Withstand Voltage (DWV)	Voltage applied for 5 ± 1 seconds, 50mA charging current maximum	
Ageing Rate	COG/NP0	Zero
	X7R	<2% per time decade

Range Dimensions – AEC-Q200 MLCC Ranges

Size	Length (L1) mm/inches	Width (W) mm/inches	Max. Thickness (T) mm/inches	Termination Band (L2) mm/inches	
				min	max
0402	1.0 ± 0.10 0.04 ± 0.004	0.50 ± 0.10 0.02 ± 0.004	0.6 0.024	0.10 0.004	0.40 0.016
0603	1.6 ± 0.15 0.063 ± 0.006	0.8 ± 0.15 0.032 ± 0.006	0.9 0.035	0.20 0.008	0.40 0.016
0805	2.0 ± 0.2 0.079 ± 0.008	1.25 ± 0.2 0.049 ± 0.008	1.3 0.051	0.25 0.010	0.75 0.03
1206	3.2 ± 0.2 0.126 ± 0.008	1.6 ± 0.2 0.063 ± 0.008	1.9 0.075	0.25 0.01	0.75 0.03
1210	3.2 ± 0.2 0.126 ± 0.008	2.5 ± 0.2 0.098 ± 0.008	2.8 0.11	0.25 0.01	0.75 0.03
1808	4.5 ± 0.35 0.180 ± 0.014	2.0 ± 0.3 0.08 ± 0.012	2.0 0.08	0.25 0.01	1.0 0.04
1812	4.5 ± 0.30 0.180 ± 0.012	3.2 ± 0.2 0.126 ± 0.008	3.2 0.126	0.25 0.01	1.14 0.045
1825	4.5 ± 0.30 0.180 ± 0.012	6.40 ± 0.4 0.252 ± 0.016	4.0 0.158	0.25 0.01	1.0 0.04
2220*	5.7 ± 0.40 0.225 ± 0.016	5.0 ± 0.4 0.197 ± 0.016	4.0 0.158	0.25 0.01	1.0 0.04
2225*	5.7 ± 0.4 0.225 ± 0.016	6.3 ± 0.4 0.252 ± 0.016	4.0 0.158	0.25 0.01	1.14 0.045
2720	6.86 ± 0.4 0.27 ± 0.016	5.08 ± 0.4 0.2 ± 0.016	4.2 0.165	0.25 0.01	0.80 0.031
3640	9.2 ± 0.5 0.36 ± 0.02	10.16 ± 0.5 0.4 ± 0.02	4.0 0.158	0.5 0.02	1.5 0.06

Custom chip sizes not included in the table, but larger than 2225, can be considered with minimum tooling charges. Please refer specific requests direct to the sales office. Max thickness relates to standard components and actual thickness may be considerably less. Thicker parts, or components with reduced maximum thickness, can be considered by request – please refer requests to the sales office.

* Leaded options are available on all options in case sizes 2220 and 2225, please see page 3 for more information.

* 2720 case size only available for Safety Certified Capacitors

Ordering Information – AEC-Q200 MLCC Range

1210	Y	100	0103	J	X	T	□□□
Chip Size	Termination	Voltage d.c. (marking code)	Capacitance in Pico farads (pF)	Capacitance Tolerance	Dielectric Codes	Packaging	Suffix Code
0603	Y = FlexiCap™ termination base with nickel barrier (100% matte tin plating). RoHS compliant.	010 = 10V	<1.0pF	H: ± 0.05pF	K = COG/NP0 (1B)	T = 178mm (7") reel	Used for specific customer requirements & variants
0805		016 = 16V	Insert a P for the decimal point as the first character.	(only available for values <4.7pF)		R = 330mm (13") reel	
1206		025 = 25V	e.g., P300 = 0.3pF	<10pF	S = X7R (2R1)	B = Bulk pack – tubs or trays	
1210	H = FlexiCap™ termination base with nickel barrier (tin/lead plating with min. 10% lead). Not RoHS compliant.	100 = 100V	Values in 0.1pF steps	B: ± 0.10pF	E = X7R (2R1) AEC-Q200	WR2 / WS3 = StackiCap	DR1 = Voltage de rating >105°C
1808		200 = 200V	≥1.0pF & <10pF	C: ± 0.25pF			
1812	J = Silver base with nickel barrier (100% matte tin plating). RoHS compliant	250 = 250V	Insert a P for the decimal point as the second character.	D: ± 0.5pF	A = COG/NP0 (1B/NP0) AEC-Q200	WR2/WR3 = StackiCap with a voltage de rating >105°C	
1825		500 = 500V	e.g., 8P20 = 8.2pF	F: ± 1%			
2220	A = Silver base with nickel barrier (tin/lead plating with min. 10% lead). Not RoHS compliant	630 = 630V	Values are E24 series	G: ± 2%	T =X8R with AEC-Q200 release	M01 = Open Mode	
2225		1K0 = 1kV	≥10pF	J: ± 5%			
3640	6 = Nickel Barrier, Sn/Pb Plated Solder (5-20% Lead, non RoHS)	1K2 = 1.2kV	First digit is 0.	K: ± 10%	Note: AEC-Q200 X7R is only available in Y or H termination.	T01 = Tandem	
		2K0 = 2kV	Second and third digits are significant figures of capacitance code.	M: ± 20%			
	7 = FlexiCap™ Polymer termination, Nickel barrier, Sn/Pb Plated Solder (5-20% Lead, non RoHS)	1K5 = 1.5kV	The fourth digit is the number of zeros following.			E01, E07 = 3 terminal EMI component	
		2K5 = 2.5kV	e.g., 0101 = 100 pF	Values are E12 series		E03 =X2Y Integrated pass component	

AEC-Q200 range – maximum capacitance values

Voltage	Dielectric	0603	0805	1206	1210	1808	1812	1825	2211	2215	2220*	2225*	3640
16/25V	COG/NP0	1nF	4.7nF	15nF	33nF	27nF	47nF	82nF	-	-	100nF	150nF	220nF
	X7R	-	100nF	470nF	1.0µF	470nF	680nF	680nF	-	-	1.5µF	-	-
50/63V	COG/NP0	1nF	4.7nF	15nF	33nF	27nF	47nF	68nF	-	-	100nF	150nF	220nF
	X7R	100nF	220nF	470nF	1.0µF	680nF	2.2µF	2.2µF	-	-	3.3µF	3.3µF	4.7µF
50V	X8R	-	33nF	120nF	220nF	270nF	470nF	-	-	-	680nF	1.0µF	-
100V	COG/NP0	680pF	2.2nF	8.2nF	18nF	15nF	39nF	47nF	-	-	56nF	68nF	180nF
	COG/NP0**	-	-	10nF	33nF	-	-	-	-	-	-	-	-
	X7R	47nF	100nF	220nF	680nF	560nF	1.0µF	1.5µF	-	-	1.5µF	2.2µF	3.3µF
	X8R	-	33nF	100nF	220nF	220nF	470nF	-	-	-	1.0µF	1.5µF	-
200V	COG/NP0	560pF	1.5nF	3.9nF	8.2nF	8.2nF	22nF	33nF	-	-	39nF	47nF	100nF
	COG/NP0**	-	-	10nF	33nF	-	-	-	-	-	-	-	-
	X7R	15nF	56nF	150nF	330nF	330nF	1.0µF	1.2µF	560nF	820nF	2.2µF	2.2µF	3.3µF
	X8R	-	15nF	68nF	150nF	150nF	330nF	-	-	-	680nF	1.0µF	-
250V	COG/NP0	560pF	1.5nF	3.9nF	8.2nF	8.2nF	22nF	33nF	-	-	39nF	47nF	100nF
	COG/NP0**	-	-	10nF	33nF	-	-	-	-	-	-	-	-
	X7R	15nF	56nF	150nF	330nF	270nF	1.0µF	1.2µF	560nF	820nF	1.8µF	2.2µF	3.3µF
	X8R	-	15nF	68nF	150nF	150nF	330nF	-	-	-	680nF	1.0µF	-
500V	COG/NP0	330pF	1.0nF	3.3nF	6.8nF	6.8nF	22nF	33nF	-	-	39nF	47nF	100nF
	COG/NP0**	-	-	10nF	33nF	-	-	-	-	-	-	-	-
	X7R	4.7nF	22nF	68nF	150nF	150nF	470nF	560nF	330nF	470nF	1.0µF	1.2µF	1.2µF
	X8R	-	4.7nF	22nF	47nF	47nF	120nF	-	-	-	330nF	470nF	-
630V	COG/NP0	-	820pF	2.7nF	6.8nF	6.8nF	22nF	33nF	-	-	39nF	39nF	100nF
	COG/NP0**	-	-	10nF	33nF	-	-	-	-	-	-	-	-
	X7R	-	10nF	47nF	100nF	100nF	330nF	470nF	220nF	330nF	1.0µF	1.0µF	680nF
	X8R	-	2.2nF	10nF	33nF	33nF	68nF	-	-	-	180nF	220nF	-
1kV	COG/NP0	-	330pF	2.2nF	3.9nF	3.9nF	10nF	22nF	-	-	22nF	27nF	68nF
	COG/NP0**	-	-	6.8nF	22nF	-	-	-	-	-	-	-	-
	X7R	-	10nF	12nF	47nF	47nF	180nF	180nF	82nF	120nF	470nF	220nF	1.0µF
	X8R	-	1.5nF	3.3nF	6.8nF	6.8nF	27nF	-	-	-	68nF	82nF	-
1.2kV	COG/NP0	-	180pF	820pF	1.8nF	2.2nF	8.2nF	18nF	-	-	22nF	27nF	56nF
	X7R	-	-	5.6nF	22nF	22nF	100nF	68nF	56nF	68nF	220nF	100nF	180nF
	X8R	-	-	2.2nF	5.6nF	5.6nF	15nF	-	-	-	47nF	56nF	-
1.5kV	COG/NP0	-	150pF	560pF	1.2nF	1.5nF	6.8nF	12nF	-	-	15nF	18nF	39nF
	X7R	-	-	5.6nF	18nF	18nF	56nF	68nF	39nF	56nF	150nF	100nF	100nF
	X8R	-	-	1.5nF	3.3nF	3.3nF	10nF	-	-	-	27nF	33nF	-
2kV	COG/NP0	-	100pF	390pF	560pF	1.0nF	3.3nF	5.6nF	-	-	6.8nF	8.2nF	15nF
	X7R	-	-	3.3nF	5.6nF	8.2nF	18nF	22nF	18nF	22nF	100nF	47nF	56nF
	X8R	-	-	680pF	1.5nF	1.5nF	5.6nF	-	-	-	15nF	22nF	-
2.5kV	COG/NP0	-	-	150pF	330pF	390pF	1.5nF	3.3nF	-	-	3.9nF	4.7nF	8.2nF
	X7R	-	-	2.2nF	4.7nF	4.7nF	10nF	18nF	10nF	15nF	22nF	33nF	39nF
	X8R	-	-	-	-	1.2nF	3.3nF	-	-	-	10nF	12nF	-
3kV	COG/NP0	-	-	100pF	220pF	270pF	1.0nF	2.2nF	-	-	3.3nF	3.9nF	6.8nF
	X7R	-	-	1.5nF	3.3nF	3.9nF	4.7nF	10nF	5.6nF	10nF	15nF	18nF	33nF
	X8R	-	-	-	-	820pF	2.7nF	-	-	-	5.6nF	6.8nF	-
4kV	COG/NP0	-	-	-	-	150pF	680pF	1.5nF	-	-	1.8nF	1.8nF	3.3nF
	X7R	-	-	-	-	2.2nF	2.2nF	-	3.3nF	4.7nF	6.8nF	10nF	10nF
5kV	COG/NP0	-	-	-	-	82pF	330pF	560pF	-	-	1.0nF	1.2nF	2.2nF
	X7R	-	-	-	-	680pF	1.0nF	1.8nF	1.2nF	2.2nF	2.7nF	3.9nF	6.8nF
6kV	COG/NP0	-	-	-	-	47pF	220pF	270pF	-	-	330pF	390pF	1.5nF
	X7R	-	-	-	-	390pF	820pF	1.0nF	560pF	820pF	1.0nF	1.5nF	4.7nF

*Leaded options are available on all options in case sizes 2220 and 2225, please see page 3 for more information.

** Low Loss variant of COG/NP0

X7R in 1812, 2220, 2225 & 3640 sizes include parts with Stackicap™ technology

Voltage de rating at temperature

Parts with a suffix code of DR1 / WR2 /WR3 have a voltage de rating above 105°C, see graph below for more information

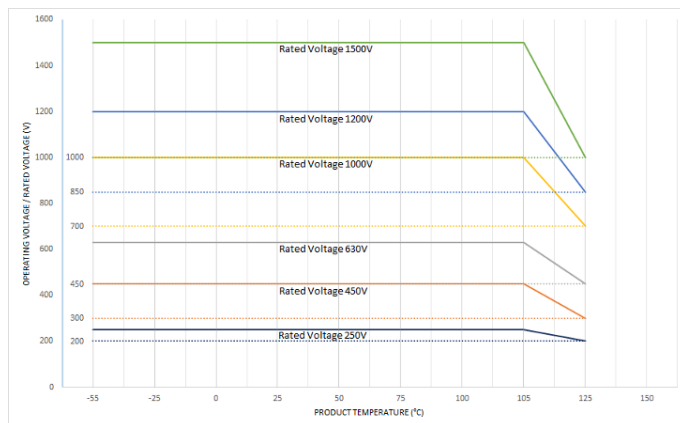

Leaded Options

Option on case sizes 2220 & 2225 for all ranges.

- Metal frame J leaded terminal
- Enhanced performance under critical testing conditions such as thermal shock and mechanical vibration
- Capable of 3000 thermal cycles with no degradation of interconnect when mounted to FR4 board
- Suitable for both industrial and automotive markets
- Offers 3kV and 4kV parts to satisfy the demands of 800V battery system DWV testing

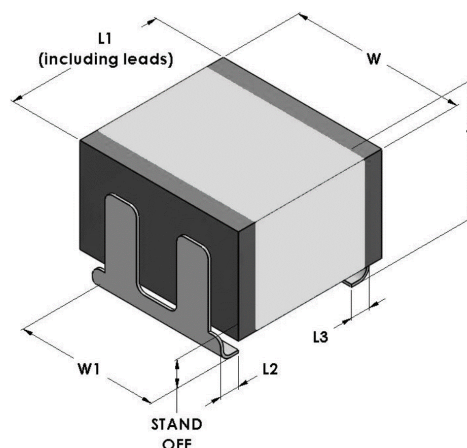

Range Dimensions – Leaded Options

Size	Length (L1) mm/inches	Width (W) mm/inches	Width (W1) mm/inches	Max. Thickness (T) mm/inches	Lead Width (L2 & L3) mm/inches		STAND OFF
					Typical		Typical
1812	5.0±0.4 0.197 ± 0.016	3.2 ± 0.4 0.126 ± 0.016	3.20 ± 0.20 0.200 ± 0.008	4.2 0.126	0.7 0.028		1.0 0.039
2220	6.0 ± 0.40 0.23 ± 0.016	5.0 ± 0.4 0.197 ± 0.016	5.10 ± 0.20 0.200 ± 0.008	5.5 0.217	0.7 0.028		1.0 0.039
2225	6.0 ± 0.4 0.23 ± 0.016	6.3 ± 0.4 0.252 ± 0.016	5.10 ± 0.20 0.200 ± 0.008	5.5 0.217	0.7 0.028		1.0 0.039

Ordering Information – AEC-Q200 MLCC Range

2220	Y	1K0	0104	J	E	T	J	□□□
Chip Size	Termination	Voltage d.c. (marking code)	Capacitance in Pico farads (pF)	Capacitance Tolerance	Dielectric Codes	Packaging	Mounting Style	Suffix Code
2220 2225	B = Uncoated	016 = 16V 025 = 25V 050 = 50V 063 = 63V 100 = 100V 200 = 200V 250 = 250V 500 = 500V 630 = 630V 1K0 = 1kV 1K2 = 1.2kV 1K5 = 1.5kV 2K0 = 2kV 2K5 = 2.5kV 3K0 = 3kV 4K0 = 4kV 5K0 = 5kV 6K0 = 6kV	<1.0pF Insert a P for the decimal point as the first character. e.g., P300 = 0.3pF Values in 0.1pF steps ≥1.0pF & <10pF Insert a P for the decimal point as the second character. e.g., 8P20 = 8.2pF Values are E24 series ≥10pF First digit is 0. Second and third digits are significant figures of capacitance code. The fourth digit is the number of zeros following. e.g., 0101 = 100 pF Values are E12 series	F: ± 1% G: ± 2% J: ± 5% K: ± 10% M: ± 20%	S = X7R (2R1) AEC-Q200 E = X7R (2R1) AEC-Q200	T = 178mm (7") reel R = 330mm (13") reel B = Bulk pack – tubs or trays	U = 'U' Leaded Assembly	Used for specific customer requirements & variants W031 = Standard Variant

3 Terminal EMI Components (Suffix E01) – AEC-Q200 range – maximum capacitance values

Voltage	Dielectric	0805	1206	1806
50V	COG/NPO	820pF	1.0nF	2.2nF
	X7R	47nF	100nF	200nF
100V	COG/NPO	560pF	1.0nF	2.2nF
	X7R	15nF	15nF	68nF

3 TERMINAL EMI CHIPS (E07) – AEC-Q200 range – maximum capacitance values

Voltage	Dielectric	0805	1206	1806	1812
25V	X7R	56nF	220nF	270nF	1.0µF
50V	COG	220pF	1.0nF	1.5nF	-
	X7R	47nF	120nF	270nF	1.0µF
100V	COG	120pF	560pF	680pF	-
	X7R	15nF	56nF	100nF	100nF
200V	X7R	-	56nF	100nF	100nF

X2Y Integrated Passive Components (Suffix E03) – AEC-Q200 ranges – min./max. capacitance values

Voltage	Dielectric	0805	1206	1410	1812
50V	COG/NPO	390pF - 470pF	1.2nF - 1.5nF	4.7nF - 5.6nF	8.2nF - 10nF
	X7R	18nF - 33nF	56nF - 150nF	180nF - 330nF	390nF - 560nF
100V	COG/NPO	10pF - 330pF	22pF - 1.0nF	100pF - 3.9nF	820pF - 6.8nF
	X7R	470pF - 15nF	1.5nF - 47nF	4.7nF - 150nF	8.2nF - 330nF

Note: For some lower capacitance parts, higher voltage parts may be supplied.

Open Mode Range (Suffix M01) AEC-Q200 range – maximum capacitance values

Voltage	Dielectric	0603	0805	1206	1210	1808	1812	1825	2220	2225
16/25V	COG/NPO	220pF	1.0nF	2.2nF	5.6nF	5.6nF	10nF	-	15nF	18nF
	X7R	22nF	100nF	220nF	470nF	-	470nF	-	560nF	-
50/63V	COG/NPO	220pF	1.0nF	2.2nF	5.6nF	5.6nF	10nF	-	15nF	18nF
	X7R	22nF	100nF	220nF	470nF	470nF	1.0µF	-	1.5µF	2.7µF
100V	COG/NPO	220pF	1.0nF	2.2nF	5.6nF	5.6nF	10nF	-	15nF	18nF
	X7R	6.8nF	27nF	100nF	220nF	270nF	680nF	-	1.0µF	1.5µF
200V	COG/NPO	150pF	680pF	1.8nF	3.9nF	3.9nF	10nF	-	15nF	18nF
	X7R	2.7nF	22nF	68nF	100nF	120nF	330nF	560nF	680nF	1.0µF
250V	COG/NPO	150pF	680pF	1.8nF	3.9nF	3.9nF	10nF	-	15nF	18nF
	X7R	2.7nF	22nF	68nF	100nF	100nF	330nF	560nF	680nF	1.0µF
500V	COG/NPO	-	470pF	1.0nF	2.2nF	2.2nF	5.6nF	-	15nF	18nF
	X7R	-	5.6nF	39nF	68nF	82nF	180nF	330nF	330nF	470nF
630V	COG/NPO	-	220pF	560pF	1.8nF	1.8nF	5.6nF	-	15nF	18nF
	X7R	-	-	22nF	33nF	47nF	100nF	220nF	180nF	330nF
1kV	COG/NPO	-	47pF	220pF	470pF	470pF	1.0nF	-	2.7nF	3.3nF
	X7R	-	-	6.8nF	15nF	18nF	47nF	100nF	100nF	150nF
1.5kV	X7R	-	-	-	-	10nF	22nF	47nF	56nF	68nF
2kV	X7R	-	-	-	-	3.3nF	8.2nF	10nF	22nF	27nF
3kV	X7R	-	-	-	-	1.5nF	1.8nF	3.9nF	5.6nF	6.8nF

Tandem Range (Suffix T01) X7R only AEC-Q200 range – maximum capacitance values

Voltage	0603	0805	1206	1210	1812
50/63V	6.8nF	33nF	100nF	180nF	390nF
100V	2.2nF	10nF	47nF	82nF	220nF
200/250V	1.0nF	4.7nF	22nF	47nF	100nF

Hiteca™ Class II High Stability AEC-Q200 range – maximum capacitance values

Voltage	1206	1210	1812	1825	2220	2225
200/250V	33nF	82nF	220nF	390nF	390nF	470nF
450V	18nF	47nF	150nF	270nF	270nF	330nF
500V	15nF	39nF	120nF	220nF	220nF	270nF
630V	10nF	22nF	68nF	150nF	150nF	180nF
1kV	3.9nF	10nF	27nF	56nF	56nF	68nF
1.2kV	2.7nF	6.8nF	18nF	39nF	39nF	47nF
1.5kV	2.2nF	4.7nF	12nF	22nF	22nF	33nF
2kV	1.0nF	2.2nF	6.8nF	12nF	12nF	18nF

Surge Protection and Safety Range – AEC-Q200 range – min./max. capacitance values

Dielectric	Approval Body	Y2/X1 SYX/UYX					Y2/X1 SYM/UYM
		1808	1812	2211	2215	2220	2220
COG	TÜV, UL	5.6pF-220pF	5.6pF-820pF	4.7pF-1nF	820pF-1.0nF	-	-
X7R	TÜV, UL	82pF-1.8nF	100pF-4.7nF	100pF-3.9nF	2.7nF-6.8nF	150pF-10nF	150pF-10nF

Dielectric	Approval Body	Y2/X1 SYS/UYS		X2 S3X/U3X	X2 S2X/U2X	
		1808	1812	2220	1808	1812
COG	TÜV, UL	5.6pF-220pF	5.6pF-680pF	-	10pF-1.0nF	10pF-1.5nF
X7R	TÜV, UL	82pF-1.8nF	100pF-3.9nF	10nF-56nF	150pF-5.6nF	150pF-10nF

Dielectric	Approval Body	Y2/X1 SYX/UYX	Y2/X1 SYM/UYM
		2720	
X7R	TÜV	1.0nF – 12nF	

Safety Certified Capacitors - AEC-Q200 ranges

Chip size	Classification		Knowles Family Code	Dielectric	Cap Range	Approval specification	Approval Body
1808	Y2 (250Vac) + X1 (305Vac)	FOWX2 + FOWX8	SYX	X7R	82pF – 1.8nF	IEC/EN60384-14:2013 +A1:2016 UL/CAN/CSA60384-14:2014	TÜV UL
				C0G	5.6pF – 220pF		
1812	Y2 (250Vac) + X1 (305Vac)	FOWX2 + FOWX8	SYX	X7R	100pF – 4.7nF	IEC/EN60384-14:2013 +A1:2016 UL/CAN/CSA60384-14:2014	TÜV UL
				C0G	5.6pF – 820pF		
2211	Y2 (250Vac) + X1 (305Vac)	FOWX2 + FOWX8	SYX	X7R	100pF – 3.9nF	IEC/EN60384-14:2013 +A1:2016 UL/CAN/CSA60384-14:2014	TÜV UL
				C0G	4.7pF – 1nF		
2215	Y2 (250Vac) + X1 (305Vac)	FOWX2 + FOWX8	SYX	X7R	2.7nF – 6.8nF	IEC/EN60384-14:2013 +A1:2016 UL/CAN/CSA60384-14:2014	TÜV UL
				C0G	820pF – 1nF		
2220	Y2 (250Vac) + X1 (305Vac)	FOWX2 + FOWX8	SYX	X7R	150pF – 10nF	IEC/EN60384-14:2013 +A1:2016 UL/CAN/CSA60384-14:2014	TÜV UL
				-	-		
2220	Y2 (250Vac) + X1 (305Vac)	FOWX2 + FOWX8	SYM	X7R	150pF – 10nF	IEC/EN60384-14:2013 +A1:2016 UL/CAN/CSA60384-14:2014	TÜV UL
				-	-		
1808	Y2 (250Vac) + X1 (305Vac)	FOWX2 + FOWX8	SYS	X7R	82pF – 1.8nF	IEC/EN60384-14:2013 +A1:2016 UL/CAN/CSA60384-14:2014	TÜV UL
				C0G	5.6pF – 220pF		
1812	Y2 (250Vac) + X1 (305Vac)	FOWX2 + FOWX8	SYS	X7R	100pF – 3.9nF	IEC/EN60384-14:2013 +A1:2016 UL/CAN/CSA60384-14:2014	TÜV UL
2220	X2 (305Vac)	FOWX2 + FOWX8	S3X	X7R	10nF – 56nF	IEC/EN60384-14:2013 +A1:2016 UL/CAN/CSA60384-14:2014	TÜV UL
				-	-		
1808	X2 (250Vac)	FOWX2 + FOWX8	S2X	X7R	150pF – 5.6nF	IEC/EN60384-14:2013 +A1:2016 UL/CAN/CSA60384-14:2014	TÜV UL
				C0G	10pF – 1.0nF		
1812	X2 (250Vac)	FOWX2 + FOWX8	S2X	X7R	150pF – 10nF	IEC/EN60384-14:2013 +A1:2016 UL/CAN/CSA60384-14:2014	TÜV UL
				C0G	10pF – 2.2nF		
2720	Y2 (310Vac) + X1 (310Vac)	-	SYX	X7R	5.6nF – 12nF	IEC/EN60384-14:2023	TÜV
2720	Y2 (440Vac) + X1 (440Vac)	-	SYX	X7R	3.9nF – 4.7nF	IEC/EN60384-14:2023	TÜV
2720	Y2 (500Vac) + X1 (500Vac)	-	SYX	X7R	1.0nF – 3.3nF	IEC/EN60384-14:2023	TÜV

Ordering Information – AEC-Q200 Safety Certified Capacitors

SYX/UYX/SYM/UYM family

1808	J	A25	0102	K	J	T	SYX
Chip Size	Termination	Rated Voltage	Capacitance in Pico farads (pF)	Capacitance Tolerance	Dielectric Codes	Packaging	Suffix code
1808 1812 2211 2215 2220	J = nickel barrier (Tin). RoHS compliant. Y = FlexiCap™ termination base with Ni barrier (100% matte tin plating). RoHS compliant.	A25 = 250Vac	First digit is 0. Second and third digits are significant figures of capacitance code. The fourth digit is number of zeros following. Example: 0102 = 1.0nF	<10pF B = ±0.10pF C = ±0.25pF D = ±0.50pF ≥ 10pF F = ±1% G = ±2% J = ±5% K = ±10% M = ±20%	G = COG/NP0 J = X7R K = COG/NP0 (1B) to AEC-Q200 S = X7R (2R1) to AEC-Q200	T = 178mm (7") reel R = 330mm (13") reel B = Bulk pack - tubs or trays	SYX/SYM = Y2 (250Vac) / X1 (305Vac) Marked + Approved UYX / UYM = Unmarked parts in accordance with above but not certified

SYX/UYX/SYM/UYM family

2720	Y	A31	0562	K	S	T	SYX
Chip Size	Termination	Rated Voltage	Capacitance in Pico farads (pF)	Capacitance Tolerance	Dielectric Codes	Packaging	Suffix code
2720	Y = FlexiCap™ termination base with Ni barrier (100% matte tin plating). RoHS compliant.	A31 = 310Vac Y2/X1 A44 = 440Vac Y2/X1 A50 = 500Vac Y2/X1	First digit is 0. Second and third digits are significant figures of capacitance code. The fourth digit is number of zeros following. Example: 0562 = 5.6nF	<10pF B = ±0.10pF C = ±0.25pF D = ±0.50pF ≥ 10pF F = ±1% G = ±2% J = ±5% K = ±10% M = ±20%	J = X7R S = X7R (2R1) to AEC-Q200	T = 178mm (7") reel R = 330mm (13") reel B = Bulk pack - tubs or trays	SYX / SYM = Y2 / X1 Marked + Approved UYX / UYM = Unmarked parts in accordance with above but not certified

*2720 case size only available with Y termination

SYS/UYX family

1808	J	A25	0102	G	J	T	SYS
Chip Size	Termination	Rated Voltage	Capacitance in Pico farads (pF)	Capacitance Tolerance	Dielectric Codes	Packaging	Suffix code
1808 1812	J = nickel barrier (Tin). RoHS compliant. Y = FlexiCap™ termination base with Ni barrier (100% matte tin plating). RoHS compliant.	A25 = 250Vac	First digit is 0. Second and third digits are significant figures of capacitance code. The fourth digit is number of zeros following. Example: 0102 = 1.0nF	<10pF B = ±0.10pF C = ±0.25pF D = ±0.50pF ≥ 10pF F = ±1% G = ±2% J = ±5% K = ±10% M = ±20%	G = COG/NP0 J = X7R	T = 178mm (7") reel R = 330mm (13") reel B = Bulk pack - tubs or trays	SYS* = Y2 (250Vac) / X1 (305Vac) Marked + Approved UYX = Unmarked parts in accordance with above but not certified

*For use in equipment within the scope of IEC 62368

S3X/U3X family

2220	Y	A30	0563	K	S	T	S3X
Chip Size	Termination	Rated Voltage	Capacitance in Pico farads (pF)	Capacitance Tolerance	Dielectric Codes	Packaging	Suffix code
2220	J = nickel barrier (Tin). RoHS compliant. Y = FlexiCap™ termination base with Ni barrier (100% matte tin plating). RoHS compliant.	A30 = 305Vac	First digit is 0. Second and third digits are significant figures of capacitance code. The fourth digit is number of zeros following. Example: 0563 = 56nF	J = ±5% K = ±10% M = ±20%	J = X7R S = X7R (2R1) to AEC-Q200	T = 178mm (7") reel R = 330mm (13") reel B = Bulk pack - tubs or trays	S3X = X2 (305Vac) Marked + Approved U3X = Unmarked parts in accordance with above but not certified

S2X/U2X family

1808	J	A25	0102	J	G	T	S2X
Chip Size	Termination	Rated Voltage	Capacitance in Pico farads (pF)	Capacitance Tolerance	Dielectric Codes	Packaging	Suffix code
1808 1812	J = nickel barrier (Tin). RoHS compliant. Y = FlexiCap™ termination base with Ni barrier (100% matte tin plating). RoHS compliant.	A25 = 250Vac	First digit is 0. Second and third digits are significant figures of capacitance code. The fourth digit is number of zeros following. Example: 0562 = 5.6nF	<10pF B = ±0.10pF C = ±0.25pF D = ±0.50pF ≥ 10pF F = ±1% G = ±2% J = ±5% K = ±10% M = ±20%	G = COG/NP0 K = COG/NP0 (1B) to AEC-Q200	T = 178mm (7") reel R = 330mm (13") reel B = Bulk pack - tubs or trays	S2X = X2 (250Vac) Marked + Approved U2X = Unmarked parts in accordance with above but not certified

Performance and Testing

	COG/NP0/X8G			X5R	X7R			X8R
	Ultra stable			Stable	Stable			Stable
IECQ-CECC	1B/CG	-	-	-	2C1	2R1	2X1	-
EIA	-	COG/NP0	-	X5R	-	X7R	-	X8R
MIL	-	-	CG (BP)	-	BZ	-	BX	-
Rated temperature range	-55°C to +125°C			-55°C to +85°C	-55°C to +125°C			-55°C to +150°C
Rated temperature range (DR1/WR2/WR3)	-			-	-55°C to +105°C/+125°C			-
Maximum capacitance change over temperature range	0 ± 30 ppm/°C			± 15%	± 20%	± 15%	± 15%	± 15%
Rated DC voltage applied				-	+20 -30%	-	+15 -25%	-
Knowles / Syfer dielectric ordering code	C			P	R	X	B	N
Tangent of loss angle (tan δ)	Cr > 50pF ≤ 0.0015 Cr ≤ 50pF = 0.0015(15 ÷ Cr + 0.7) Low Loss ≤ 0.001			≤ 0.025	≤ 0.025			≤ 0.025
Insulation resistance (Ri) OR Time constant (Ri*Cr) (whichever is the least)	100G Ω or 1000s			100G Ω or 1000s	100G Ω or 1000s			100G Ω or 1000s
Capacitance tolerance (ordering code)	Cr <4.7pF	± 0.05pF (H) ± 0.10pF (B) ± 0.25pF (C) ± 0.50pF (D)		± 5% (J) ± 10% (K) ± 20% (M)	± 5% (J) ± 10% (K) ± 20% (M)	± 5% (J) ± 10% (K) ± 20% (M)	± 5% (J) ± 10% (K) ± 20% (M)	
	Cr <10pF	± 0.10pF (B) ± 0.25pF (C) ± 0.50pF (D)						
	Cr ≥10pF	± 1% (F) ± 2% (G) ± 5% (J) ± 10% (K)						
Dielectric strength	Voltage applied for 5 seconds max. Charging current limited to 50mA maximum.							
<200V >200V to <500V 500V to <1000V >1kV to <1200V >1000V >1200V	2.5 times Rated voltage + 250V 1.5 times 1.25 times - 1.2 times			2.5 times - - - -	2.5 times Rated voltage + 250V 1.5 times 1.5 times 1.2 times -			2.5 times - - - -
Climatic category (IEC)								
Chip	55/125/56			55/85/56	55/125/56			55/150/56
Ageing characteristic (Typical)	Zero			<2% per time decade	<2% per time decade			<2% per time decade

Soldering Information

Knowles MLCCs are compatible with all recognised soldering/mounting methods for chip capacitors. A detailed application note is available at syfer.com

Reflow Soldering

Knowles recommend reflow soldering as the preferred method for mounting MLCCs. Knowles MLCCs can be reflow soldered using a reflow profile generally defined in IPC/FEDEC J-STD-020. Sn plated termination chip capacitors are compatible with both conventional and lead free soldering with peak temperatures of 260 to 270°C acceptable.

The heating ramp rate should be such that components see a temperature rise of 1.5 to 4°C per second to maintain temperature uniformity through the MLCC.

The time for which the solder is molten should be maintained at a minimum, so as to prevent solder leaching. Extended times above 230°C can cause problems with oxidation of Sn plating. Use of an inert atmosphere can help if this problem is encountered. Palladium/Silver (Pd/Ag) terminations can be particularly susceptible to leaching with free lead, tin rich solders and trials are recommended for this combination.

Cooling to ambient temperature should be allowed to occur naturally, particularly if larger chip sizes are being soldered. Natural cooling allows a gradual relaxation of thermal mismatch stresses in the solder joints. Forced cooling should be avoided as this can induce thermal breakage.

Wave Soldering

Wave soldering is generally acceptable, but the thermal stresses caused by the wave have been shown to lead to potential problems with larger or thicker chips. Particular care should be taken when soldering SM chips larger than size 1210 and with a thickness greater than 1.0mm for this reason.

Maximum permissible wave temperature is 270°C for SM chips.

The total immersion time in solder should be kept to a minimum. It is strongly recommended that Sn/Ni plated terminations are specified for wave soldering applications.

Solder Leaching

Leaching is the term for the dissolution of silver into the solder causing a failure of the termination system which causes increased ESR, tan δ and open circuit faults, including ultimately the possibility of the chip becoming detached.

Leaching occurs more readily with higher temperature solders and solders with a high tin content. Pb free solders can be very prone to leaching certain termination systems. To prevent leaching, exercise care when choosing solder allows and minimize both maximum temperature and dwell time with the molten solder.

Plated terminations with nickel or copper anti-leaching barrier layers are available in a range of top coat finishes to prevent leaching occurring. These finishes also include Knowles FlexiCap™ for improved stress resistance post soldering.

Reflow Soldering for Leaded Parts

Reflow solder in accordance with IPC-A-610. Recommended reflow profile as laid down in IPC/JEDEC J-STD-020.

Wave soldering not possible for Tab leaded stand-off parts.

Peak re-flow temperature (Tp) 250°C. Solder volume should be calculated such that the meniscus between tab and board remains under the 'cut-out' guidance edge on the tab (see diagram). Excessive solder or heat may reflow the solder between the lead and MLCC, impacting the integrity of the joint

Hand soldering of Tab leaded parts is not recommended.

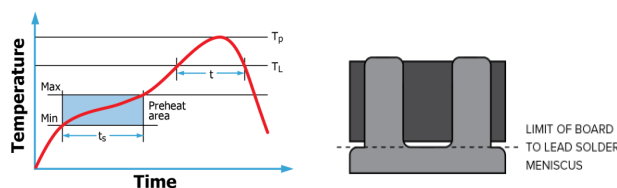

Multilayer ceramic chip with nickel or copper barrier termination

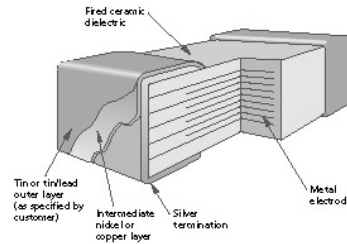

Rework of Chip Capacitors

Knowles recommend hot air/gas as the preferred method of applying heat for rework. Apply even heat surrounding the component to minimise internal thermal gradients. Soldering irons or other techniques that apply direct heat to the chip or surrounding area should not be used as these can result in micro cracks being generated.

Minimise the rework heat duration and allow components to cool naturally after soldering.

Use of Silver Loaded Epoxy Adhesives

Chip capacitors can be mounted to circuit boards using silver loaded adhesive provided the termination material of the capacitor is selected to be compatible with the adhesive. This is normally PdAg. Standard tin finishes are often not recommended for use with silver loaded epoxies as there can be electrical and mechanical issues with the joint integrity due to material mismatch.

Handling & Storage

Components should never be handled with fingers; perspiration and skin oils can inhibit solderability and will aggravate cleaning.

Chip capacitors should never be handled with metallic instruments. Metal tweezers should never be used as these can chip the product and leave abraded metal tracks on the product surface. Plastic or plastic coated metal types are readily available and recommended – these should be used with an absolute minimum of applied pressure.

Incorrect storage can lead to problems for the user. Rapid tarnishing of the terminations, with an associated degradation of solderability, will occur if the product comes into contact with industrial gases such as sulphur dioxide and chlorine. Storage in free air, particularly moist or polluted air, can result in termination oxidation.

Packaging should not be opened until the MLCs are required for use. If opened, the pack should be re-sealed as soon as practicable. Alternatively, the contents could be kept in a sealed container with an environmental control agent.

Long term storage conditions, ideally, should be temperature controlled between -5 and +40°C and humidity controlled between 40% and 60% R.H.

Taped product should be stored out of direct sunlight, which might promote deterioration in tape or adhesive performance.

Product, stored under the conditions recommended above, in its "as received" packaging, has a minimum shelf life of 2 years.

SM Pad Design

Knowles conventional 2-terminal chip capacitors can generally be mounted using pad designs in accordance with IPC-7351, Generic Requirements for Surface Mount Design and Land Pattern Standards, but there are some other factors that have been shown to reduce mechanical stress, such as reducing the pad width to less than the chip width. In addition, the position of the chip on the board should also be considered.

3-terminal components are not specifically covered by IPC-7351, but recommended pad dimensions are included in the Knowles catalogue/website for these components.

FlexiCap™ Termination

FlexiCap™ has been developed as a result of listening to customer's experiences of stress damage to MLCCs from many manufacturers, often caused by variations in production processes.

Our answer is a proprietary flexible epoxy polymer termination material, that is applied to the device under the usual nickel barrier finish. FlexiCap™ will accommodate a greater degree of board bending than conventional capacitors.

All ranges are available with FlexiCap™ termination material offering increased reliability and superior mechanical performance (board flex and temperature cycling) when compared with standard termination materials. Refer to Knowles application note reference AN0001. FlexiCap™ capacitors enable the board to be bent almost twice as much as before mechanical cracking occurs. Refer to application note AN0002.

FlexiCap™ is also suitable for space applications having passed thermal vacuum outgassing tests. Refer to Knowles application note reference AN0026.

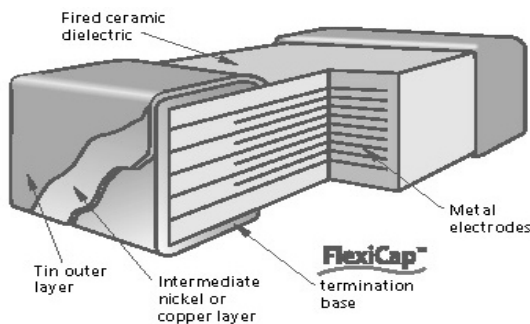

FlexiCap™ MLCC cross section

Knowles has delivered millions of FlexiCap™ components and during that time has collected substantial test and reliability data, working in partnership with customers world wide, to eliminate mechanical cracking.

An additional benefit of FlexiCap™ is that MLCCs can withstand temperature cycling from -55° to 125°C in excess of 1,000 times without cracking.

FlexiCap™ termination has no adverse effect on any electrical parameters, nor affects the operation of the MLCC in any way.

Application Notes

FlexiCap™ may be handled, stored and transported in the same manner as standard terminated capacitors. The requirements for mounting and soldering FlexiCap™ are the same as for standard SMD capacitors.

For customers currently using standard terminated capacitors there should be no requirement to change the assembly process when converting to FlexiCap™.

Based upon the board bend tests in accordance with IEC 60384-1 the amount of board bending required to mechanically crack a FlexiCap™ terminated capacitor is significantly increased compared with standard terminated capacitors.

Product: X7R	Typical bend performance under AEC-Q200 test conditions
Standard Termination	2mm to 3mm
FlexiCap™	Typically 8mm to 10mm

REACH (Registration, Evaluation, Authorisation and restriction of Chemicals) Statement

The main purpose of REACH is to improve the protection of human health and the environment from the risks arising from the use of chemicals.

Knowles monitors the REACH legislation to ensure compliance. All products made by Knowles are 'articles' under the definition of REACH and a certificate of compliance is maintained on our website www.knowlescapacitors.com/syfer.

For further information, please contact the sales office at SyferSales@knowles.com

RoHS Compliance

Knowles routinely monitors world wide material restrictions (e.g., EU/China and Korea RoHS mandates) and is actively involved in shaping future legislation.

All standard C0G/NPO, X7R, X5R and High Q Knowles MLCC products are compliant with the EU RoHS directive (see below for special exemptions) and those with plated terminations are suitable for soldering common lead free solder alloys (refer to 'Soldering Information' for more details on soldering limitations). Compliance with EU RoHS directive automatically signifies compliance with some other legislation (e.g., Korea RoHS). Please refer to the Sales Office for details of compliance with other materials legislation.

Breakdown of material content, SGS analysis reports and tin whisker test results are available on request.

Most Knowles MLCC components are available with non-RoHS compliant tin/lead (SnPb) Solderable termination finish for exempt applications and where pure tin is not acceptable. Other tin free termination finishes may also be available – please refer to the Sales Office for further details.

X8R ranges <250Vdc are not RoHS 2011/65/EU compliant.

Check the website, www.knowlescapacitors.com/syfer for latest RoHS update.

Export Controls and Dual-use Regulations

Certain Knowles catalogue components are defined as 'dual-use' items under international export controls – those that can be used for civil and military purposes which meet certain specified technical standards.

The defining criteria for a dual-use component with respect to Knowles products is one with a voltage rating of >750V and a capacitance value >250nF and a series inductance <10nH.

Components defined as 'dual-use' under the above criteria automatically require a licence for export outside the EU, and may require a licence for export with the EU.

The application for a licence is routine, but customers for these products will be asked to supply further information.

Please refer to the sales office if you require any further information on export restrictions.

Other special components may additionally need to comply with export regulations.

Ageing of Ceramic Capacitors

Capacitor ageing is a term used to describe the negative, logarithmic capacitance change which takes place in ceramic capacitors with time. The crystalline structure for barium titanate based ceramics changes on passing through its Curie temperature (known as the Curie Point) at about 125°C. The domain structure relaxes with time and in doing so, the dielectric constant reduces logarithmically; this is known as the ageing mechanism of the dielectric constant. The more stable dielectrics have the lowest ageing rates.

The ageing process is reversible and repeatable. Whenever the capacitor is heated to a temperature above the Curie Point the ageing process starts again from zero.

The ageing constant, or ageing rate, is defined as the percentage loss of capacitance due to the ageing process of the dielectric which occurs during a decade of time (a tenfold increase in age) and is expressed as percent per logarithmic decade of hours. As the law of decrease of capacitance is logarithmic, this means that a capacitor with an ageing rate of 1% per decade of time, the capacitance will decrease at a rate of:

- 1% between 1 and 10 hours
- An additional 1% between the following 10 and 100 hours
- An additional 1% between the following 100 and 1000 hours
- An additional 1% between the following 1000 and 10000 hours
- The ageing rate continues in this manner throughout the capacitor's life.

Typical values of the ageing constant for our MLCCs are

Dielectric Class	Typical Values
Ultra Stable COG/NPO	Negligible capacitance loss through ageing
Stable X7R	<2% per decade of time

Capacitance Measurements

Because of ageing it is necessary to specify an age for reference measurements at which the capacitance shall be within the prescribed tolerance. This is fixed at 1000 hours, since for all practical purposes there is not much further loss of capacitance after this time.

All capacitors shipped are within their specified tolerance at the standard reference age of 1000 hours after having cooled through their Curie temperature.

The ageing curve for any ceramic dielectric is a straight line when plotted on semi-log paper.

Capacitance vs Time

(Ageing X7R @ 1% per decade)

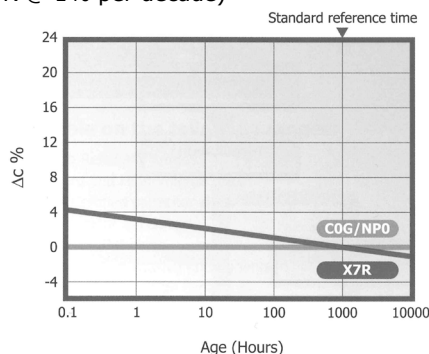

Tight Tolerance

One of the advantages of Knowles's unique 'wet process' of manufacture is the ability to offer capacitors with exceptionally tight capacitance tolerances.

The accuracy of the printing screens used in the fully automated, computer controlled manufacturing process allows for tolerance as close as ± 1% on COG/NPO parts greater than or equal to 10pF. For capacitance value less than 4.7pF tolerances can be as tight as ± 0.05pF.

Periodic Tests Conducted and Reliability Data

For standard surface mount capacitors components are randomly selected on a sample basis and the following routine tests conducted:

- Load Test. 1,000 hours @ 125°C (150oOC for X8R). Applied voltage depends on components tested
- Humidity Test. 168 hours @ 85°C/85%RH
- Board Deflection (bend test)

Test results are available on request.

Conversion Factors

From	To	Operation
FITs	MTBF (hours)	$10^9 \div \text{FITs}$
FITs	MTBF (years)	$10^9 \div (\text{FITs} \times 8760)$

FIT = Failures In Time. 1 FIT = 1 failure in 10^9 hours

MTBF = Mean Time Between Failure

Example of FIT Data Available

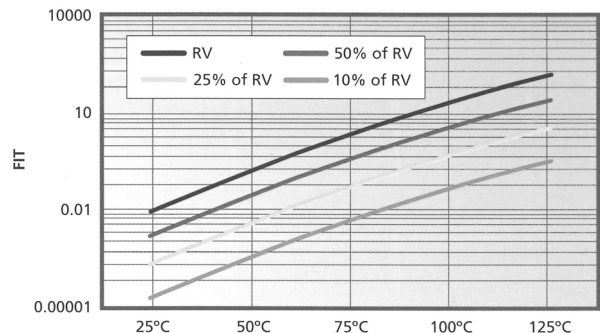

Component type: 0805 (COG/NPO and X7R)

Testing Location: Knowles reliability test department

Results based on: 16,622,000 component test hours

Packaging Information

Tape and reel packing of surface mounting chip capacitors for automatic placement are in accordance with IEC60286-3.

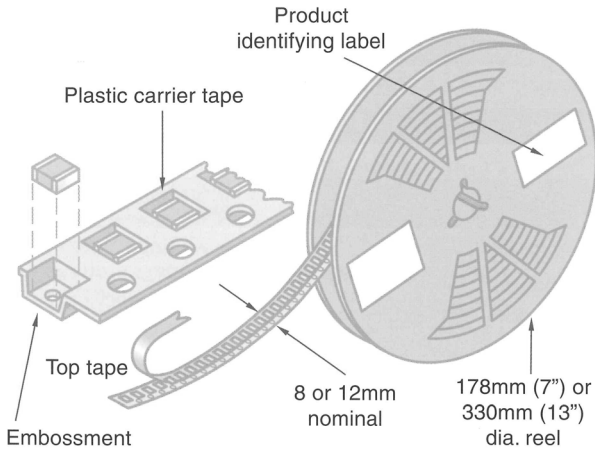

Peel Force

The peel force of the top sealing tape is between 0.2 and 1.0 Newton at 180°. The breaking force of the carrier and sealing tape in the direction of unreeling is greater than 10 Newtons.

Reel Dimensions

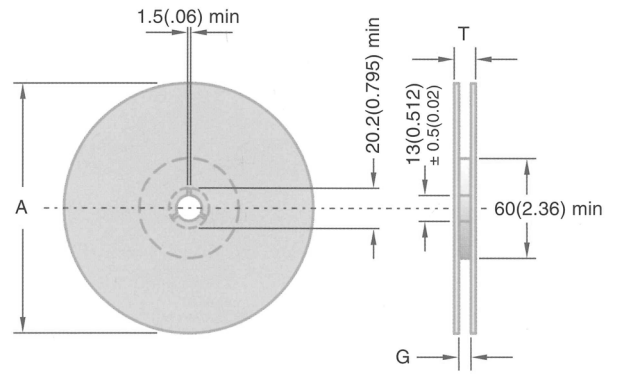

Symbol	Description	178mm Reel	330mm Reel
A	Reel diameter	178 (7)	330 (13)
G	Reel inside width	8.4 (0.33)	12.4 (0.49)
T	Reel outside width	14.4 (0.56) max	18.4 (0.72) max

Tape Dimensions

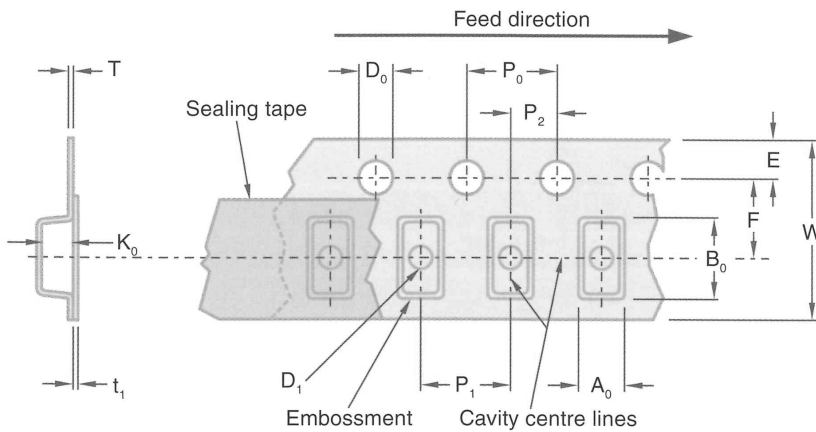

Symbol	Description	Dimensions mm (inches)	
		8mm Tape	12mm Tape
A ₀	Width of cavity	Dependent on chip size to minimize rotation	
B ₀	Length of cavity		
K ₀	Depth of cavity		
W	Width of tape	8.0 (0.315)	12.0 (0.472)
F	Distance between drive hole centres and cavity centres	3.5 (0.138)	5.5 (0.213)
E	Distance between drive hole centres and tape edge	1.75 (0.069)	
P ₁	Distance between cavity centres	4.0 (0.156)	8.0 (0.315)
P ₂	Axial distance between drive hole centres and cavity centres	2.0 (0.079)	
P ₀	Axial distance between drive hole centres	4.0 (0.156)	
D ₀	Drive hole diameter	1.5 (0.059)	
D ₁	Diameter of cavity piercing	1.0 (0.039)	1.5 (0.059)
XT	Carrier tape thickness	0.3 (0.012) ± 0.1 (0.04)	0.4 (0.016) ± 0.1 (0.04)
Xt ₁	Top tape thickness	0.1 (0.004) max	

Packing Information

Missing Components

The number of missing components in the tape may not exceed 0.25% of the total quantity with not more than three consecutive components missing. This must be followed by at least six properly placed components

Identification

Each reel is labelled with the following information: manufacturer, chip size, capacitance, tolerance, rated voltage, dielectric type, batch number, date code and quantity of components.

Component Orientation

Tape and reeling is in accordance with IEC 60286 part 3, which defines the packaging specifications for leadless components on continuous tapes.

- Notes:
- 1) IEC60286-3 states A0 < B0
 - 2) Regarding the orientation of 1825 and 2225 components, the termination bands are right to left, NOT front to back. Please see diagram.

Leader Trailer

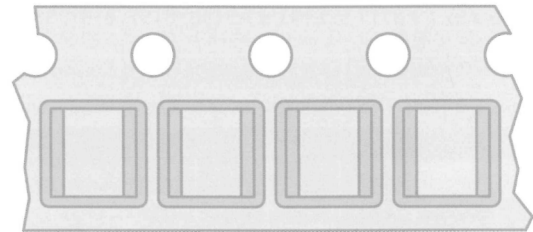
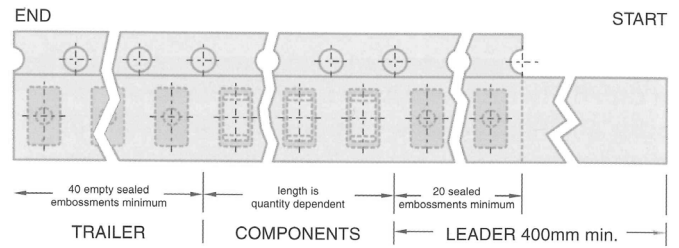

Orientation of 1825 & 2225 components

Outer Packaging

Outer carton dimensions mm (inches) max

Reel Size	No. of Reels	L	W	T
178 (7)	1	185 (7.28)	185 (7.28)	25 (0.98)
178 (7)	4	190 (7.48)	195 (7.76)	75 (2.95)
330 (13)	1	335 (13.19)	335 (13.19)	25 (0.98)

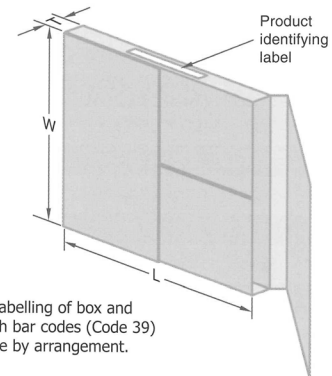

Note: Labelling of box and reel with bar codes (Code 39) available by arrangement.

Reel Quantities

Chip Size	0402	0505	0603	0805	1111	1206	1210	1410	1808	1812	1825	2211	2215	2220	2225	2720
Max. Chip Thickness	0.5mm	1.3mm	0.8mm	1.3mm	2.0mm	1.6mm	2.0mm	2.0mm	2.0mm	2.5mm	2.5mm	2.5mm	2.5mm	2.5mm	2.5mm	4.2mm
	0.02"	0.05"	0.03"	0.05"	0.08"	0.06"	0.08"	0.08"	0.08"	0.1"	0.1"	0.1"	0.1"	0.1"	0.1"	0.17"
Reel Quantities	178mm (7")	10000	2500	4000	3000	1000	2500	2000	2000	1500	500	500	750	500	500	500
	330mm (13")	15000	10000	16000	12000	5000	10000	8000	8000	6000	2000	2000	4000	4000	2000	1000

Notes:

- 1) The above quantities per reel are for the maximum manufactured chip thickness. Thinner chips can be taped in larger quantities per reel.
- 2) Where two different quantities are shown for the same case size, please contact the sales office to determine the exact quantity for any specific part number.

Bulk Packing – Tubs

Chips are supplied in rigid re-sealable plastic tubs together with impact cushioning wadding. Tubs are labelled with the details: chip size, capacitance, tolerance, rated voltage, dielectric type, batch number, date code and quantity of components.

Dimensions mm (inches)

H	60mm (2.36")
D	50mm (1.97")

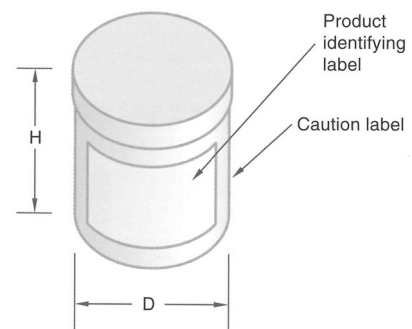

Looking for pricing, stock, or lifecycle information?

Click below to explore more details on WIN SOURCE:

 [View 2220YA250471KJTSYX on WIN SOURCE](#)

 [Knowles Syfer](#) Information

Optimize Your Supply Chain with WIN SOURCE Solutions

-  Global Sourcing Solution
-  Obsolete Management
-  Cost Control Management
-  Shortage Management
-  Alternative Solution
-  Excess Inventory Management