

Features

- Wide operating voltage (V1mA) range from 18V to 1800V
- Fast responding to transient over-voltage.
- Large absorbing transient energy capability.
- Low clamping ratio and no following-on current.



General Information

- Surge protection in consumer electronics
- Surge protection in industrial electronics
- Relay and electromagnetic valve surge absorption
- Transistor, diode, IC, thyristor or triac semiconductor protection
- Surge protection in electronic home appliances, gas and petroleum appliances
- Agency: UL(E479668),CUL(E479668), CQC(22001337353),TUV(J50541477)

General Characteristics

- Body: Nickel Plated
- Devices with No Leads: Nickel Plated
- Storage Temperature: -40 °C to +125°C
- Axial Devices: Tin Plated

Part Number Code

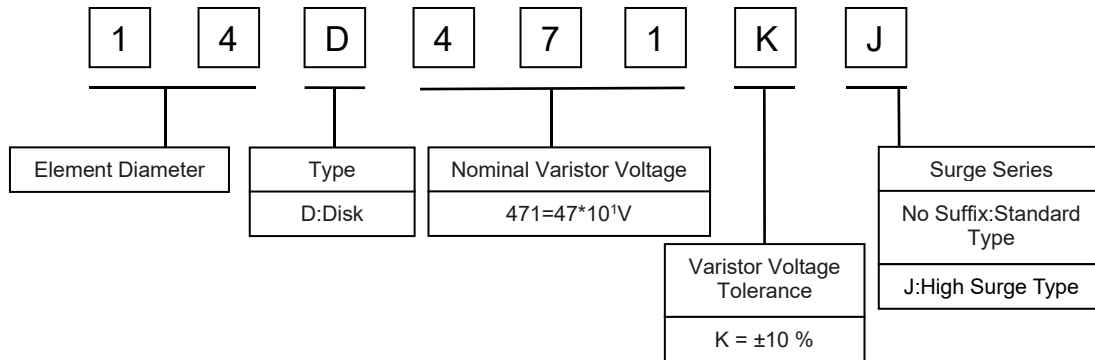

Agency Information

Agency Information		Agency File Number	Operating temperature range
	UL	E479668	- 40° C to 125° C
	CUL	E479668	- 40° C to 105° C
	CQC	22001337360	- 40° C to +125° C
	TUV	J50541477	- 40° C to +125° C

Electrical Characteristics

Type Number		Varistor Voltage	Max. Allowable Voltage		Max. Energy (10/1000 μ s)		Max. Clamping Voltage (8/20 μ s)		Withstanding Surge Current (8/20 μ s)		Rated Power	Typical Capacitance (Reference)
Standard	High Surge	V _{1mA} (V)	V _{AC} (V)	V _{DC} (V)	(J) Standard	(J) High Surge	I _p (A)	V _c (V)	I(A) Standard	I(A) High Surge	(W)	@1KHz(pf)
14D180K	/	15~22	11	14	5.7	/	10	38	1000	/	0.1	18000
14D220K	/	20~26	14	18	7.0	/	10	43	1000	/	0.1	15000
14D270K	/	24.3~31.1	17	22	8.5	/	10	53	1000	/	0.1	10000
14D330K	/	29.7~37.9	20	26	10	/	10	65	1000	/	0.1	8500
14D390K	/	35.2~44.8	25	31	12	/	10	77	1000	/	0.1	7500
14D470K	/	43~53	30	38	15	/	10	93	1000	/	0.1	6500
14D560K	/	51~63	35	45	18	/	10	110	1000	/	0.1	5600
14D680K	/	62~76	40	56	21	/	10	135	1000	/	0.1	4700
14D820K	14D820KJ	74~90	50	65	26	31	50	135	4500	6000	0.6	3900
14D101K	14D101KJ	90~110	60	85	32	38	50	165	4500	6000	0.6	3400
14D121K	14D121KJ	108~132	75	100	38	46	50	200	4500	6000	0.6	3100
14D151K	14D151KJ	135~165	95	125	47	56	50	250	4500	6000	0.6	3000
14D181K	14D181KJ	162~198	115	150	57	60	50	300	4500	6000	0.6	1030
14D201K	14D201KJ	185~225	130	170	63	82	50	340	4500	6000	0.6	970
14D221K	14D221KJ	198~242	140	180	69	90	50	360	4500	6000	0.6	840
14D241K	14D241KJ	216~264	150	200	76	98	50	395	4500	6000	0.6	710
14D271K	14D271KJ	243~297	175	225	85	116	50	455	4500	6000	0.6	650
14D301K	14D301KJ	270~330	195	250	95	128	50	505	4500	6000	0.6	600
14D331K	14D331KJ	297~363	210	275	104	140	50	550	4500	6000	0.6	550
14D361K	14D361KJ	324~396	230	300	113	158	50	595	4500	6000	0.6	500
14D391K	14D391KJ	351~429	250	320	123	170	50	650	4500	6000	0.6	480
14D431K	14D431KJ	387~473	275	350	136	185	50	710	4500	6000	0.6	440
14D471K	14D471KJ	423~517	300	385	148	205	50	775	4500	6000	0.6	420
14D511K	14D511KJ	459~561	320	418	148	220	50	842	4500	6000	0.6	390
14D561K	14D561KJ	504~616	350	460	148	240	50	920	4500	6000	0.6	360
14D621K	14D621KJ	558~682	385	505	148	250	50	1025	4500	6000	0.6	320
14D681K	14D681KJ	612~748	420	560	148	260	50	1120	4500	6000	0.6	290
14D751K	14D751KJ	675~825	460	615	158	270	50	1240	4500	6000	0.6	260
14D781K	14D781KJ	702~858	485	640	164	275	50	1290	4500	6000	0.6	230
14D821K	14D821KJ	738~902	510	670	172	280	50	1355	4500	6000	0.6	230
14D911K	14D911KJ	819~1001	550	745	191	295	50	1500	4500	6000	0.6	200
14D951K	14D951KJ	855~1045	580	780	199	305	50	1570	4500	6000	0.6	190
14D102K	14D102KJ	900~1100	625	825	210	335	50	1650	4500	6000	0.6	180
14D112K	14D112KJ	990~1210	680	895	231	360	50	1815	4500	6000	0.6	150
14D142K	14D142KJ	1260~1540	870	1150	295	370	50	2310	4500	6000	0.6	140
14D152K	14D152KJ	1350~1650	900	1220	312	375	50	2475	4500	6000	0.6	140
14D182K	14D182KJ	1620~1980	1000	1465	378	450	50	2970	4500	6000	0.6	120

Electrical Ratings

Items	Test Condition/Description	Requirement					
Varistor Voltage	The voltage between two terminals with the specified measuring current 1mA.DC applied is called Vb.						
Maximum Allowable Voltage	The recommended maximum sine wave voltage (RMS) or the Maximum DC voltage can be applied continuously.						
Maximum Clamping Voltage	<p>The maximum voltage between two terminals with the specification standard impulse current. Applied waveform: 8/20μs</p> <p style="text-align: center;"> $T_1 = 1.25 * T = 8\mu s \pm 20\%$ $T_2 = 20\mu s \pm 20\%$ </p>		To meet the Specified value				
Rated Wattage	The maximum average power that can be applied within the specified ambient temperature.						
Energy	The maximum energy within the varistor voltage change of ±10% when one impulse of 10/1000μs or 2ms is applied.						
Withstanding Surge Current	The maximum current within the varistor voltage change of ±10% with the standard impulse current (8/20μs) applied one time.						
Surge Life	<p>The change of Vb shall be measured after the impulse listed below which is applied 10,000 times continuously with the interval of ten seconds at room temperature.</p> <table border="1" style="margin-left: auto; margin-right: auto;"> <tr> <td rowspan="2" style="text-align: center;">14Φ series</td> <td style="text-align: center;">180K to 680K</td> <td style="text-align: center;">75A (8/20μs)</td> </tr> <tr> <td style="text-align: center;">820K to 182K</td> <td style="text-align: center;">150A (8/20μs)</td> </tr> </table>	14Φ series	180K to 680K	75A (8/20μs)	820K to 182K	150A (8/20μs)	$\frac{\Delta V_b}{V_b} \leq \pm 10\%$
14Φ series	180K to 680K		75A (8/20μs)				
	820K to 182K	150A (8/20μs)					

Soldering Recommendation

Wave Lead Free Soldering Recommendation



Item	Conditions
Peak Temperature	265°C
Dipping Time	10 seconds (max.)
Soldering	1 time

Recommendation Reworking Conditions with Soldering Iron

Item	Conditions
Temperature of Soldering Iron-tip	360°C (max.)
Soldering Time	3 seconds (max.)
Distance from Varistor	2mm (min.)

Dimensions



Symbol	Millimeters	Inches
H(max)	20.0	0.787
L(min)	15.0	0.591
D(max)	17.0	0.669
D1(±1.0)	7.5	0.295
K(max)	2.0	0.079
T(max)	TABLE 2	
d(±0.1)	0.8	0.031

Packaging Quantity: 250pcs/bag

TABLE 2---T(max.)

Model	Millimeters	Inches	Model	Millimeters	Inches
18V~39V	4.6	0.181	430V~560V	6.2	0.244
47V~68V	5.1	0.201	620V~780V	7.2	0.283
82V~150V	4.6	0.181	820V~1200V	8.4	0.331
180V~270V	5.1	0.201	1300V~1500V	9.5	0.374
330V~390V	5.6	0.220	1600V~1800V	11.3	0.445



系列 Series	压敏电压 Varistor Voltage	编带包装数量 Taping Packaging Quantity	
		数量 (K) /内盒 QTY (k) /Linner Box	数量 (K) /箱 QTY (k) /Carton
14D	751K~182K	0.4	3.2

安全注意事项 SAFETY PRECAUTIONS

使用压敏电阻器时，压敏电阻器周围条件（设备设计中的材料、环境、电源条件、电路条件等）发生异常时，则可能引发火灾、触电、烧伤、以及产品故障。

In case that a varistor is used, if an abnormality takes place because of peripheral conditions of the varistor(material, environments, power source conditions, circuit conditions, etc. In equipment design), fire, electric shock, burn, or product failure may be occur.

下列内容为使用时的相关注意事项，请认真确认后再行使用。如对未及事项有疑议，请速与我公司担当部门联系。

The precautions for this product are described below; understand the content thoroughly before usage. For more questions, contact us.

1 严格遵守事项

Precautions to be strictly observed

1.1 额定性能确认

Confirmation of performance ratings

请遵守压敏电阻器的最大连续工作电压，耐冲击电流、最大能量耐量、浪涌寿命、额定功率和操作温度范围等额定性能的规定，在规定的范围内使用。

Use the varistor within its rated range of performance such as the maximum continuous operating voltage, withstanding surge current, maximum energy, impulse life, rated power and operating temperature range.

超出规定范围使用，则会造成压敏电阻器性能劣化，破坏元件，严重可引起压敏电阻器冒烟或起火。

If used outside the range, the varistor can be degrade and have element fracture, which may result in smoking and ignition.

1.2 为避免意外现象发生，请采用如下对策

To avoid accidents due to unexpected phenomena, take the following measures

- 1) 压敏电阻器受损时，可能出现破碎飞散，因此要对集成产品加保护盖或外盒。

In the event of fracture of the varistor, its pieces may scatter; hence, put the case or cover of the set product in place.

- 2) 请勿安装在可燃物品（塑料电线、树脂合成物等）附近。若无法避免，请使用不燃性保护外壳。

Do not install the varistor near combustible substances (polyvinyl chloride wires, resin moldings, etc.). If it's difficult to do, install a nonflammable cover.

- 3) 线间使用

Across-the-line use

在线间使用时，将保险丝与压敏电阻器串联。

When the varistor is used across a line, put a current fuse in series with the varistor.

- 4) 线-地间使用

Use between line to ground

- a) 在线-地间使用时，压敏电阻器短路时会产生接地电阻，电流保险丝不会熔断，可能引起压敏电阻器外涂层树脂冒烟或起火。

If the case that the varistor is used between a line to the ground, the short circuit of the varistor may not blow the current fuse because of grounding resistance, which may cause smoking and ignition of the varistors exterior resin.

为避免上述情况，请在电源端安装漏电断路器。如无漏电断路器，则需将电流保险丝与温度保险丝串联使用。

As the measure against it, install an earth leakage breaker on the power supply side of the varistor position. If no earth leakage breaker is installed, use a

thermal fuse together with a current fuse in series.

- b) 在带电部件与金属部件之间使用压敏电阻器时，压敏电阻器短路时有触电危险，故请将金属部件接地或勿与人体接触。

If the case that the varistor is used between a live parts to metal case, an electric shock may develop at a shortcircuit of the varistor; hence, ground the metal case to the ground or keep it from the human body.

2 使用注意事项

Application notes

2.1 注意下列事项，可能导致压敏电阻器寿命缩短或引发故障

Pay attention to the following items to avoid the shortened life and failure of the varistor.

1) 电路条件

Circuit conditions

a) 选定的压敏电阻器的电压最大值在最大连续工作电压值之上。

Select a varistor of which the maximum voltage including fluctuations in source voltage allows for the maximum permissible circuit voltage.

b) 短间隔性地施加浪涌时（施加抗干扰模拟试验电压时），不可超过压敏电阻器的额定功率。

In cases that surges are intermittently applied at short intervals (for example, in case that the voltage of the noise simulator test is implemented etc.),

c) 选定压敏电阻器时，须按照表 1 的标准产品型号。

Select a varistor recommended in table 1.

① 线间使用

Across-the-line use

单相三线式连线时单独配线负荷导致负荷不平衡、电压线和中性线短路、中性线欠损、容量性负荷情况下开闭时的共振等，将导致电源电压的上升，可能使用表 1 中标有 * 的产品型号。

If possible, use a part no. Marked with * in case of voltage temporarily rises load unbalance of separately-wired loads, short between hot and neutral-line, open of neutral line in single-phase-three-wired system, and due to resonance at switching for a capacitive, inductive load.

② 线-地间使用

Used between line to ground

出现故障时，对地电压将上升，因此，请使用附表 1 中推荐的产品型号。

Use a different part no. From "across-the-line use" as table 1, because of raising voltage in case of "line to ground fault".

进行设备的绝缘电阻试验（DC500V）时，请使用表 1 中推荐的标有 ** 的产品型号。使用不可清除绝缘性能试验的压敏电阻电压时，在一定的电路条件下，试验时可将压敏电阻器从电路上取下。

Use a varistor marked with ** in table 1, in case of the insulation resistance test (500Vdc) for equipment. When using a part of the varistor voltage that the insulation efficiency examination can not be cleared, there is a case where the varistor can be done by removing it from the circuit depending on the circuit condition.

进行设备的耐电压试验（AC1000V 或 AC1200V）时，请使用表 1 中推荐的标有 *** 的产品型号。

Use a varistor marked with *** in table 1, in case of the withstanding voltage test (1000Vac or 1200Vac) for equipment.

d) 关于电流保险丝

Concerning current fuse

① 所用压敏电阻器与电流保险丝的额定电流，一般推荐按下表进行选定。此外，在用户端，当压敏电阻器损坏时，确认其设备是否会发生 2 次伤害。

We recommend selecting a varistor and the rated current of a current fuse as follows. Finally, please be sure that there is no danger if the varistor mounted on the equipment breaks

规格 Specs	05D	07D	10D	14D	20D
保险丝额定电压 Fuse rated current	≤2A	≤5A	≤5A	≤10A	≤10A

② 保险丝的插入部位建议按表 1 操作。

The recommended fuse position is shown in table 1.

e) 温度保险丝

Concerning thermal fuse

将压敏电阻器与温度保险丝连接时，用户端请尽量选用热结合较好的保险丝。

Set a thermal fuse to get high thermal conductivity with varistor.

表 1 – 压敏电阻器的适用范例

类别 Type	线间使用 Across-the-line use	线-地使用 Use between line to ground																														
连接范例 Connections example	<p>DC/AC 单相 DC/AC 3-phase</p> <p>Fuse MOV1</p>	<p>Fuse Thermal Fuse MOV1 MOV2</p>																														
	<p>AC 3-phase 三相</p> <p>Fuse MOV3</p>	<p>Fuse Thermal Fuse MOV3 MOV4</p>																														
压敏电阻 选型举例 Example of varistor	<table border="1"> <thead> <tr> <th>MOV</th> <th>电源电压 Source voltage</th> <th>压敏电压 Varistor</th> </tr> </thead> <tbody> <tr> <td rowspan="6">MOV1 MOV3</td> <td>AC100V</td> <td>201~361*</td> </tr> <tr> <td>AC120V</td> <td>241~431*</td> </tr> <tr> <td>AC200V</td> <td>431~561*</td> </tr> <tr> <td>AC220V</td> <td>471~621*</td> </tr> <tr> <td>AC240V</td> <td>511~621*</td> </tr> <tr> <td>AC380V</td> <td>821</td> </tr> </tbody> </table>	MOV	电源电压 Source voltage	压敏电压 Varistor	MOV1 MOV3	AC100V	201~361*	AC120V	241~431*	AC200V	431~561*	AC220V	471~621*	AC240V	511~621*	AC380V	821	<table border="1"> <thead> <tr> <th>MOV</th> <th>电源电压 Source voltage</th> <th>压敏电阻 Varistor</th> </tr> </thead> <tbody> <tr> <td rowspan="5">MOV2 MOV4</td> <td>AC100V</td> <td>471,511,621*</td> </tr> <tr> <td>AC220V</td> <td>821***, 182****</td> </tr> <tr> <td>AC230V</td> <td>511,621*</td> </tr> <tr> <td>AC240V</td> <td>821***, 182****</td> </tr> <tr> <td>AC380V</td> <td>112***, 182****</td> </tr> </tbody> </table>	MOV	电源电压 Source voltage	压敏电阻 Varistor	MOV2 MOV4	AC100V	471,511,621*	AC220V	821***, 182****	AC230V	511,621*	AC240V	821***, 182****	AC380V	112***, 182****
MOV	电源电压 Source voltage	压敏电压 Varistor																														
MOV1 MOV3	AC100V	201~361*																														
	AC120V	241~431*																														
	AC200V	431~561*																														
	AC220V	471~621*																														
	AC240V	511~621*																														
	AC380V	821																														
MOV	电源电压 Source voltage	压敏电阻 Varistor																														
MOV2 MOV4	AC100V	471,511,621*																														
	AC220V	821***, 182****																														
	AC230V	511,621*																														
	AC240V	821***, 182****																														
	AC380V	112***, 182****																														

2.2 使用环境

Operating environments

- 1) 压敏电阻器不可在室外使用。
The varistor is designed to be used indoors. Do not use it exposed outdoors.
- 2) 不可在阳光直射场所、发热源附近或温度超过使用温度范围的场所使用。
Do not use the varistor in places exposed to temperatures beyond the operating temperature range, such as places exposed to sunlight and vicinities of heating equipment.
- 3) 不可在淋雨、蒸汽、高湿度的场所使用。
Do not use the varistor in places exposed to high temperatures and high humidity, such as places exposed directly to rain, wind, dew condensation, and vapor.
- 4) 不可在粉尘或盐分较多的场所以及被腐蚀性气体污染的环境中使用。
Do not use the varistor in dusty and salty places and atmospheres polluted by corrosive gases.

2.3 加工条件

Processing conditions

- 1) 不可采用可能导致外涂层树脂劣化的溶剂（稀释剂、丙酮等）进行清洗。
Do not wash the varistor by such solvents (thinner, acetone, etc) as its exterior resin deteriorates.
- 2) 不可施加可能导致外涂层树脂或元件出现破损的冲击或撞击、压力。
Do not apply a strong vibration or shock (by falling, etc) to the varistor, cracking to its exterior resin and element may occur.
- 3) 将压敏电阻器进行树脂镀膜（含护膜塑模）时，不可使用可能导致压敏电阻器劣化的树脂。
When coating the varistor with resin (including molding), do not use such resin.
- 4) 压敏电阻器外涂层树脂附近的引线部位不可进行强烈折弯或施加外力。
Do not bend the varistor lead wires at the position close to its varistor exterior resin, or apply external force to the position.
- 5) 焊接时，请在如下条件下进行。且不可将构成压敏电阻器的焊接部位或绝缘材料熔化。
When soldering the varistor lead wires, follow the recommended conditions and do not melt the solder and insulating materials constituting the varistor.

焊接方式 Soldering method	推荐条件 Recommended condition	注意事项 Attention item
波峰焊 Flow soldering	260°C, 10 秒以内 260°C, within 10 sec	引线型不是回流焊对象产品 Lead wires type is not reflow soldering object part.
上述以外的条件下使用时，请用户端自行确认。 For use other than the above conditions, please the client to confirm. 仅限进行 1 次返工，烙铁温度 350°C 以下，时间控制在 5 秒以内。 Only 1 times rework, soldering iron temperature should not exceed 350°C and should not be applied for more than 5		

- 推荐焊接条件
Soldering temperature-time profile to recommend

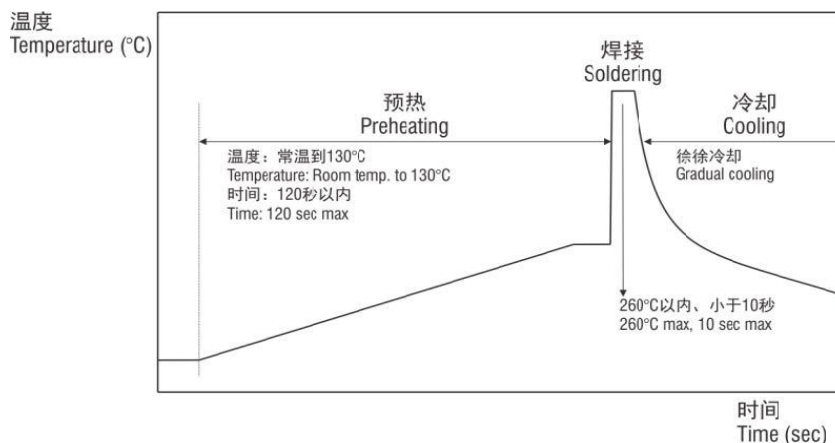

2.4. 长期保管

Long-term storage

- 1) 压敏电阻器不可保存在高温、高湿场所。保存场所室温 40 °C 以下，湿度 75%RH 以下，保存期限为 1 年。
Do not store the varistor under high temperature and high humidity. Store it at a temperature up to 40 °C and at humidity below 75% RH, and use it within 1 year.
长期期间保管（1 年以上）时，使用时请确认产品的可焊性。
Before using the varistor that has been stored for a long period (1 years or longer), confirm the solderability.
- 2) 不可保存在腐蚀性气体（硫化氢、亚硫酸、氯气、氨气等）环境中。
Avoid atmospheres full of corrosive gases (hydrogen sulfide, sulfurous acid, chlorine, ammonia, etc).
- 3) 保存场所避免阳光直射、结露等。
Avoid direct sunlight and dew condensation.

3 说明

Notices

用于可靠性要求极高的设备（航空航天设备、医疗设备等）时，请事先至本公司咨询使用型号和保护措施等相关事宜。

In cases that the varistor is used in equipment (aerospace equipment, medical equipment, etc) requiring extremely high reliability, ask us for a selection of part no., and protection coordination, etc in advance.

若未按照产品规格书记载事项进行操作，并由此导致出现异常时，本公司不负任何责任。

Note that we do not take any responsibility for faults and abnormalities resulting from the use not in conformity with the contents of entries in the delivery specification.

出现使用电路电压的异常上升、超高浪涌的侵入等不可预期因素时，可能导致压敏电阻器起火。为防止延烧到使用设备上，外部结构材料需使用阻燃材料进行多重保护。

There is a possibility that the varistor will unexpectedly cause smoke or ignite because of an abnormal rise of the circuit voltage and invasion of excessive surge. To prevent that accident from spreading over the equipment and not to expand the damage, use multiplex protection such as the adoption of flame-retardant materials for housing parts and structural parts.

Looking for pricing, stock, or lifecycle information?

Click below to explore more details on WIN SOURCE:

- [View 14D270K on WIN SOURCE](#)
- [Ruilongyuan Electronics Co.,Ltd Information](#)

Optimize Your Supply Chain with WIN SOURCE Solutions

- ✓ Global Sourcing Solution
- ✓ Obsolete Management
- ✓ Cost Control Management
- ✓ Shortage Management
- ✓ Alternative Solution
- ✓ Excess Inventory Management