



# THE DATASHEET OF FAN8024CD



# FAN8024CD

## 4-Channel Motor Driver

### Features

- 2-Channel BTL driver with current feedback
- 2-Channel BTL DC motor driver
- Built-in thermal shutdown circuit
- Built-in mute circuit
- Operating supply voltage: 4.5~13.2V

### Description

The FAN8024CD is a monolithic IC, suitable for 2-ch BTL DC motor drivers and 2-ch motor drivers with current feedback which drive the focus and tracking actuators of a CD- media system.

28-SSOPH-375



### Typical Applications

- Compact disk ROM (CD-ROM)
- Compact disk RW (CD-RW)
- Digital video disk ROM (DVD-ROM)
- Digital video disk RAM (DVD-RAM)
- Digital video disk player (DVDP)
- Other compact disk media

### Ordering Information

Device	Package	Operating Temp.
FAN8024CD	28-SSOPH-375	-25 °C ~ 85 °C
FAN8024CDTF	28-SSOPH-375	-25 °C ~ 85 °C

## Pin Assignments

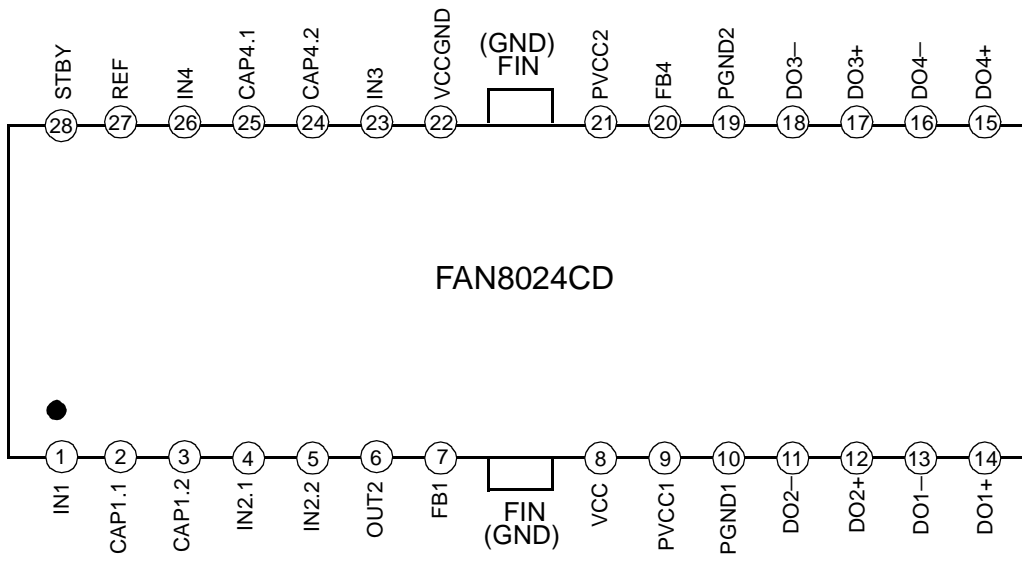

## Pin Definitions

Pin Number	Pin Name	I/O	Pin Function Description
1	IN1	I	CH1 input
2	CAP1.1	-	Connection with capacitor for CH1
3	CAP1.2	-	
4	IN2.1	I	OP-AMP CH2 input(+)
5	IN2.2	I	OP-AMP CH2 input(-)
6	OUT2	O	OP-AMP CH2 output
7	FB1	I	Feedback for CH1
8	VCC	-	Signal Vcc
9	PVCC1	-	Power Supply 1
10	PGND1	-	Power Ground 1
11	DO2-	O	Drive2 Output (-)
12	DO2+	O	Drive2 Output (+)
13	DO1-	O	Drive1 Output (-)
14	DO1+	O	Drive1 Output (+)
15	DO4+	O	Drive4 Output (+)
16	DO4-	O	Drive4 Output (-)
17	DO3+	O	Drive3 Output (+)
18	DO3-	O	Drive3 Output (-)
19	PGND2	-	Power Ground 2
20	FB4	-	Feedback for CH4
21	PVCC2	-	Power Supply 2
22	VCCGND	-	Vcc ground
23	IN3	I	CH3 input
24	CAP4.2	-	Connection with capacitor for CH4
25	CAP4.1	-	
26	IN4	I	CH4 input
27	REF	I	Bias voltage input
28	STBY	I	Stand-by input

# Internal Block Diagram

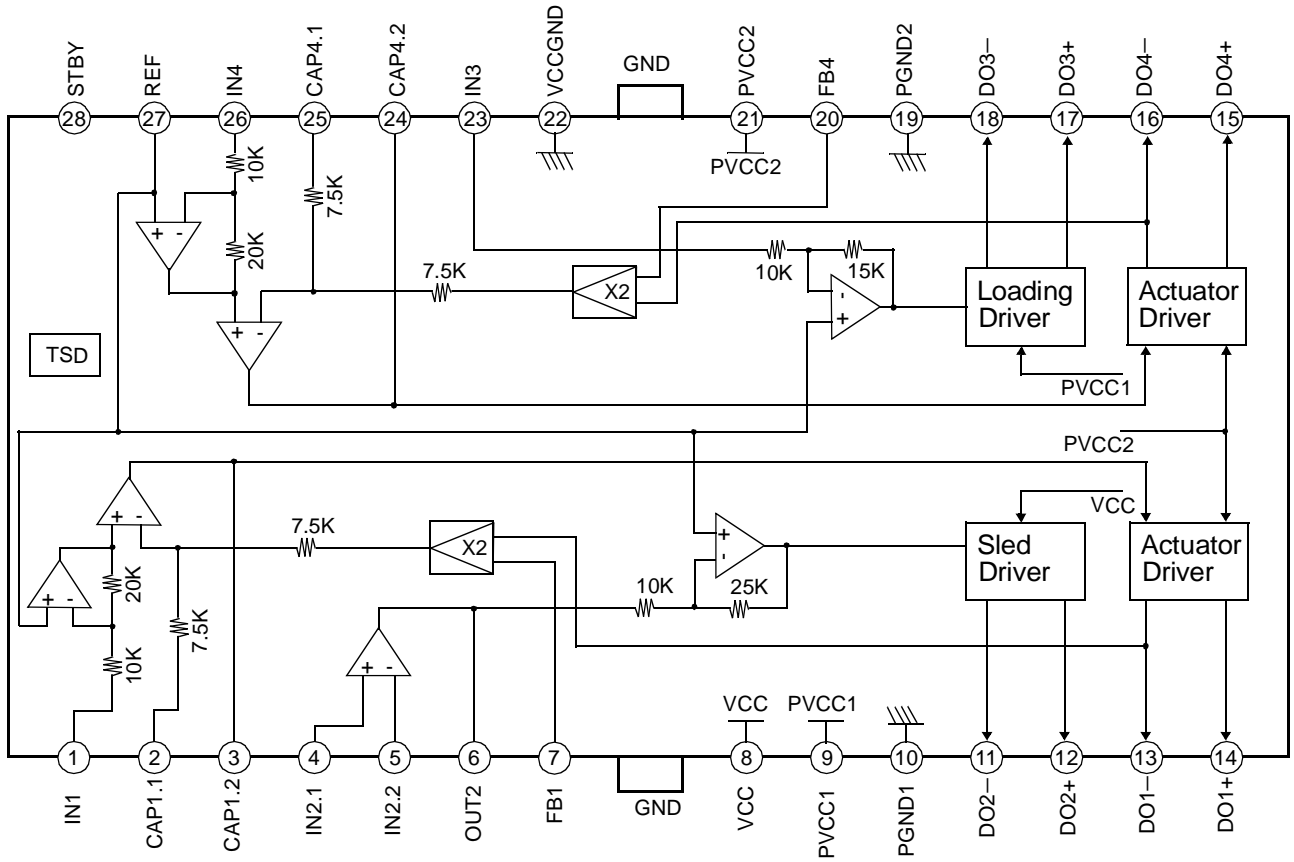

## Equivalent Circuits

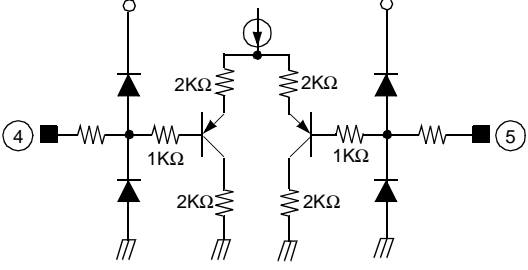
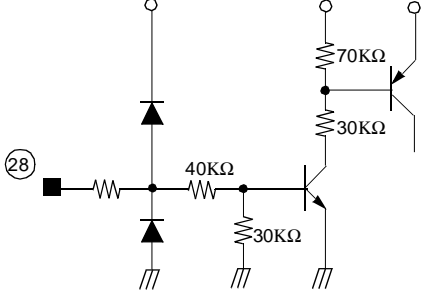
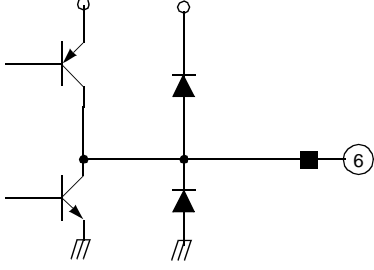
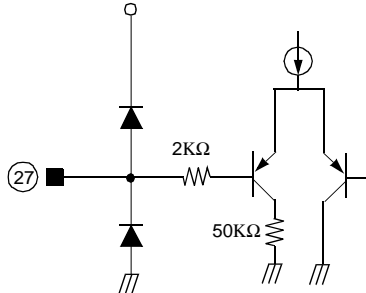
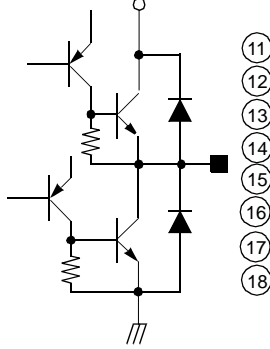
ERROR AMP INPUT	STAND-BY INPUT
	
ERROR AMP OUTPUT	SIGNAL REFERENCE INPUT
	
POWER AMP OUTPUT	
	

### Absolute Maximum Ratings (Ta = 25°C)

Parameter	Symbol	Value	Unit
Maximum supply voltage	V <sub>CCmax</sub>	15	V
Power dissipation	P <sub>D</sub>	1.7 <sup>note</sup>	W
Operating temperature range	T <sub>OPR</sub>	-25 ~ +85	°C
Storage temperature range	T <sub>STG</sub>	-55 ~ +150	°C

**NOTE:**

1. When mounted on a 50mm × 50mm × 1mm PCB (Phenolic resin material).
2. Power dissipation derating rate : -13.6mW/°C(Ta≥25°C)
3. Should not exceed Pd(Power dissipation) and SOA(Safe operating area).

### Power Dissipation Curve

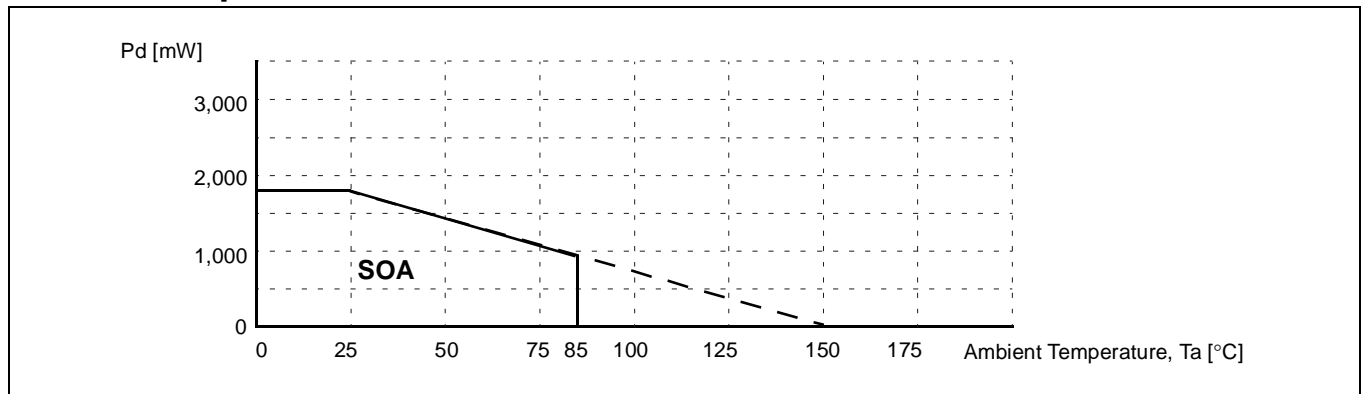

### Recommended Operating Conditions (Ta = 25°C)

Parameter	Symbol	Min.	Typ.	Max.	Unit
Supply Voltage	V <sub>CC</sub>	4.5	-	13.2	V
Supply Voltage	PV <sub>CC1</sub> , PV <sub>CC2</sub>	-	V <sub>CC</sub>	-	V

## Electrical Characteristics

(Unless otherwise specified, Ta = 25 °C, VCC = 12V, PVCC1,2 = 5V)

Parameter	Symbol	Conditions	Min.	Typ.	Max.	Unit
Quiescent Current1	ICC1	Stand-by off	-	18	27	mA
Quiescent Current1	ICC2	Stand-by on	-	-	0.5	mA
Stand-by On Voltage	VSTon	-	-	-	0.5	V
Stand-by Off Voltage	VSToff	-	2.0	-	-	V
<b>ACTUATOR DRIVE CIRCUIT</b>						
Output Offset Current	IOO1,4	-	-6	0	+6	mA
Maximum Output Voltage1	VOM1,4	-	3.6	4.0	-	V
Transconductance	GM1,4	VIN = 100mVp-p, f=1kHz	1.5	1.7	1.9	A/V
<b>PRE OP AMP (SLED DRIVER)</b>						
Common mode Input Range*	VOOM	-	0	-	11.0	V
Input Bias Current	IB	-	-300	-30	-	nA
Low Level Output Voltage	VOL	-	-	0.1	0.3	V
High Level Output Voltage	VOH	-	10	10.9	-	V
Output Source Current	ISOURCE	-	1	4	-	mA
Output Sink Current	ISINK	-	5	10	-	mA
<b>SLED DRIVE CIRCUIT</b>						
Output Offset voltage2	VOF2	-	-100	0	+100	mV
Maximum Output Voltage2	VOM2	-	10.0	10.9	-	V
Closed loop Voltage Gain1	GVLO2	VIN = 100mVp-p, f=1kHz	18.0	20.0	22.0	dB
<b>Loading DRIVE CIRCUIT</b>						
Output Offset Voltage1	VOF3	-	-50	0	50	mV
Maximum Output Voltage 3	VOM3	-	3.6	4.0	-	V
Closed loop Voltage Gain 2	GVLO3	VIN = 100mVp-p, f=1KHz	13.5	15.5	17.5	dB

\* : Guaranteed design value

## Application Information

### 1. Reference Input & Stand-by Function

- Reference input (PIN 27)  
The applied voltage at the reference input pin must be ranged between 0.8V and 6.5V, when  $V_{CC}=8.5V$ .
- Stand-by input (PIN 28)  
The following input conditions must be satisfied for the stand-by function.

Stand-by input voltage	OPERATION
below 0.5V or open	The stand-by function is activated so the bias block and power block are disabled
above 2.0V	Recover the normal operation

### 2. Protection Function

Thermal shutdown (TSD)

If the chip temperature rises above 175°C, the thermal shutdown (TSD) circuit is activated and the output circuit enters the mute state, that is off state. The TSD circuit has a temperature hysteresis of 25°C

### 3. Separation Of Power Supply

- $PV_{CC1}$  (PIN 9)  
 $PV_{CC1}$  is the power supply for the loading driver. The range is between 5V ~ 12V.
- $PV_{CC2}$  (PIN 21)  
 $PV_{CC2}$  is the power supply for the actuator drivers that include focus and tracking actuators. The range is between 5V ~ 12V
- $V_{CC}$  (PIN 8)  
 **$V_{CC}$  pin supplies power for the sled driver and the signal logic part.  $V_{CC} \geq PV_{CC1}(PV_{CC2})$ .**

#### 4. Current feedback channels(channel 1 & 4)

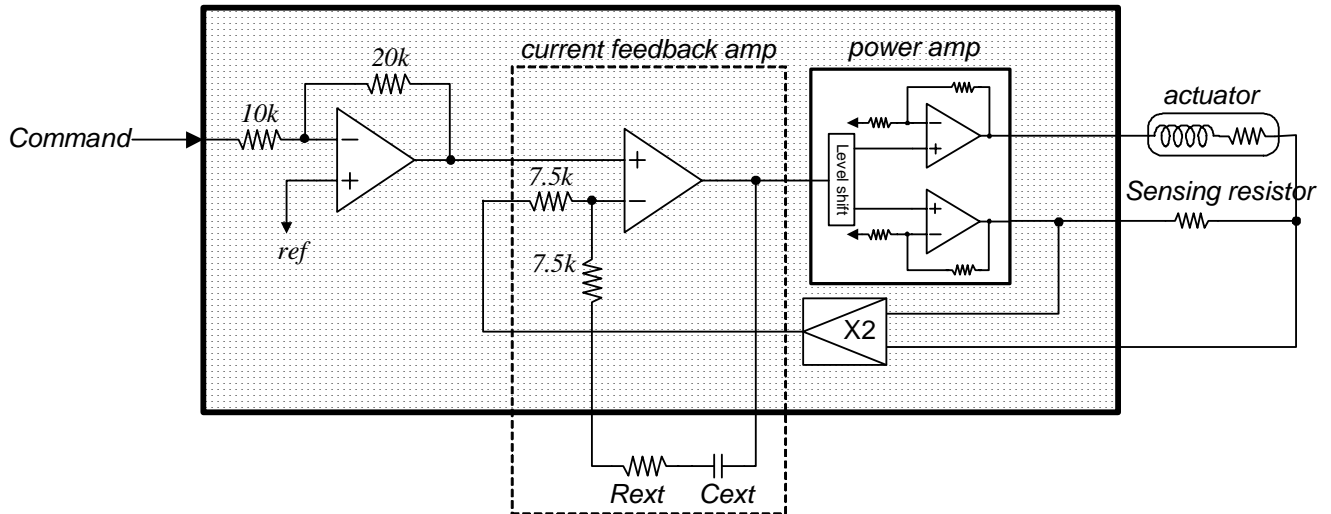

- The reference voltage(ref) is given externally through pin 27.
- The input OP-amp output signal is amplified by (20K/10K) times and then fed to the current feedback amplifier.
- The current feedback amplifier compares the output current sensed input and command input then makes the controlled output to eliminate delay effect of the load. Please refer to the application note for more information about current feedback theory(<http://www.fairchildsemi.com/an/AN/AN-4109.pdf>).
- The DC gain of current feedback amplifier and power amplifier is unity, that is 1 [A/V]. Users can change the gain by adding external resistor at the command input.

#### 5. Channel 2 schematic

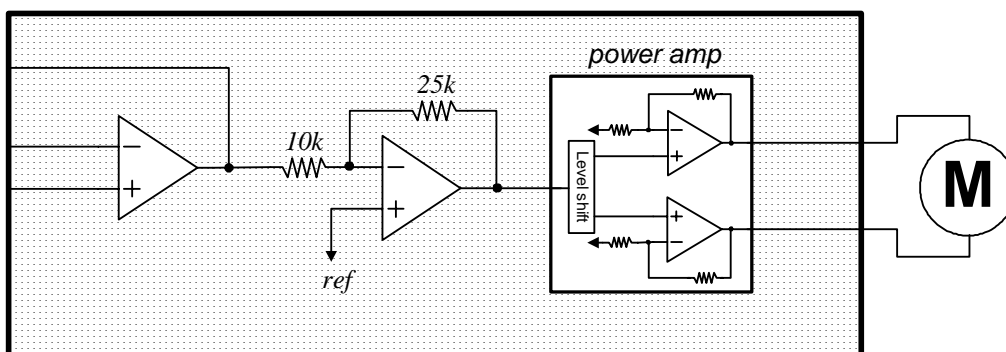

- The reference voltage(ref) is given externally through pin 27.
- The input OP-amp can be used for several purposes, for example low pass filter, differential input coordinator, gain scaler and so on.

## 6. Channel 3 schematic

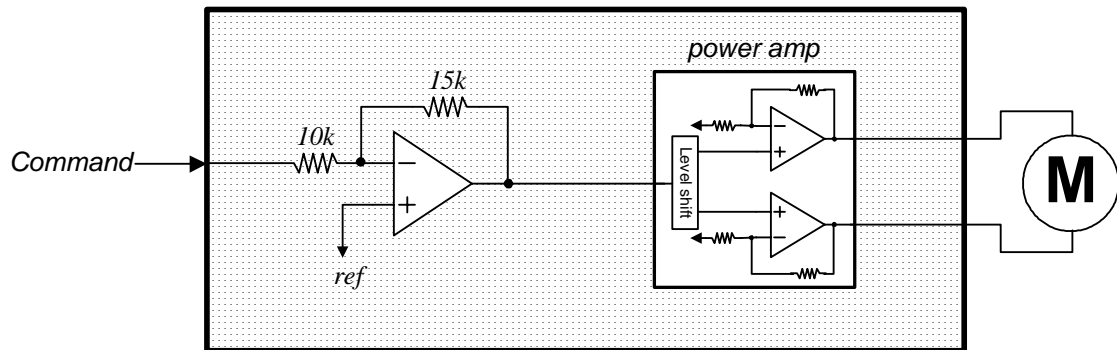

- The reference voltage(ref) is given externally through pin 27.
- The input OP-amp output signal is amplified by (15K/10K) times and then fed to the power amplifier. The gain of power amplifier is 4 so the total max gain of channel 3 is 6.
- Users must check input command range to use max output voltage because the total gain is relatively smaller than other channels.

# Typical Application Circuits

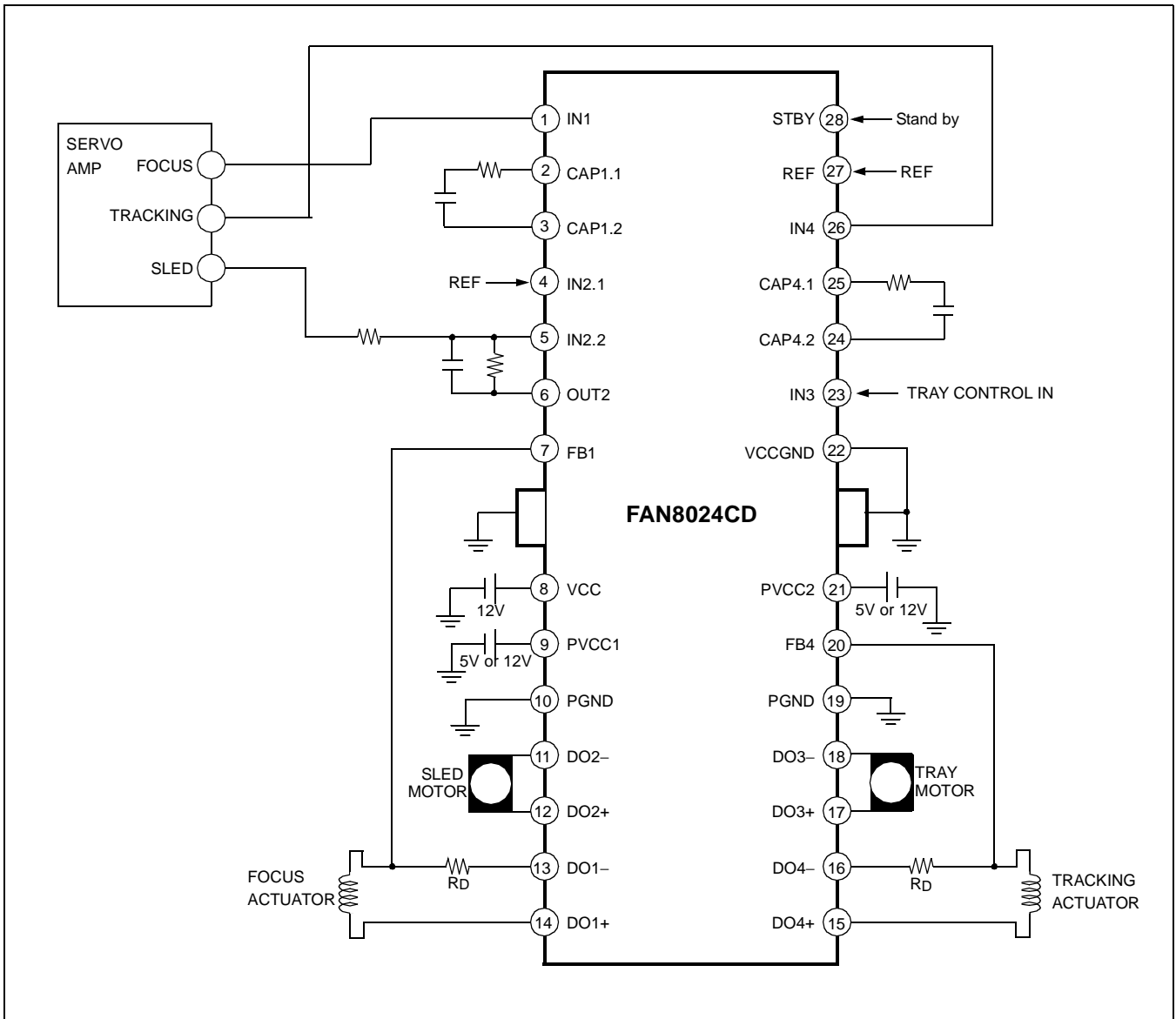

**DISCLAIMER**

FAIRCHILD SEMICONDUCTOR RESERVES THE RIGHT TO MAKE CHANGES WITHOUT FURTHER NOTICE TO ANY PRODUCTS HEREIN TO IMPROVE RELIABILITY, FUNCTION OR DESIGN. FAIRCHILD DOES NOT ASSUME ANY LIABILITY ARISING OUT OF THE APPLICATION OR USE OF ANY PRODUCT OR CIRCUIT DESCRIBED HEREIN; NEITHER DOES IT CONVEY ANY LICENSE UNDER ITS PATENT RIGHTS, NOR THE RIGHTS OF OTHERS.



**LIFE SUPPORT POLICY**

FAIRCHILD'S PRODUCTS ARE NOT AUTHORIZED FOR USE AS CRITICAL COMPONENTS IN LIFE SUPPORT DEVICES OR SYSTEMS WITHOUT THE EXPRESS WRITTEN APPROVAL OF THE PRESIDENT OF FAIRCHILD SEMICONDUCTOR CORPORATION. As used herein:

1. Life support devices or systems are devices or systems which, (a) are intended for surgical implant into the body, or (b) support or sustain life, and (c) whose failure to perform when properly used in accordance with instructions for use provided in the labeling, can be reasonably expected to result in a significant injury of the user.
2. A critical component in any component of a life support device or system whose failure to perform can be reasonably expected to cause the failure of the life support device or system, or to affect its safety or effectiveness.

## Looking for pricing, stock, or lifecycle information?

Click below to explore more details on WIN SOURCE:

-  [View FAN8024CD on WIN SOURCE](#)
-  [Fairchild/ON Semiconductor Information](#)

## Optimize Your Supply Chain with WIN SOURCE Solutions

-  Global Sourcing Solution
-  Obsolete Management
-  Cost Control Management
-  Shortage Management
-  Alternative Solution
-  Excess Inventory Management