



Is Now Part of



**ON Semiconductor®**

To learn more about ON Semiconductor, please visit our website at  
[www.onsemi.com](http://www.onsemi.com)

Please note: As part of the Fairchild Semiconductor integration, some of the Fairchild orderable part numbers will need to change in order to meet ON Semiconductor's system requirements. Since the ON Semiconductor product management systems do not have the ability to manage part nomenclature that utilizes an underscore (\_), the underscore (\_) in the Fairchild part numbers will be changed to a dash (-). This document may contain device numbers with an underscore (\_). Please check the ON Semiconductor website to verify the updated device numbers. The most current and up-to-date ordering information can be found at [www.onsemi.com](http://www.onsemi.com). Please email any questions regarding the system integration to [Fairchild\\_questions@onsemi.com](mailto:Fairchild_questions@onsemi.com).

ON Semiconductor and the ON Semiconductor logo are trademarks of Semiconductor Components Industries, LLC dba ON Semiconductor or its subsidiaries in the United States and/or other countries. ON Semiconductor owns the rights to a number of patents, trademarks, copyrights, trade secrets, and other intellectual property. A listing of ON Semiconductor's product/patent coverage may be accessed at [www.onsemi.com/site/pdf/Patent-Marking.pdf](http://www.onsemi.com/site/pdf/Patent-Marking.pdf). ON Semiconductor reserves the right to make changes without further notice to any products herein. ON Semiconductor makes no warranty, representation or guarantee regarding the suitability of its products for any particular purpose, nor does ON Semiconductor assume any liability arising out of the application or use of any product or circuit, and specifically disclaims any and all liability, including without limitation special, consequential or incidental damages. Buyer is responsible for its products and applications using ON Semiconductor products, including compliance with all laws, regulations and safety requirements or standards, regardless of any support or applications information provided by ON Semiconductor. "Typical" parameters which may be provided in ON Semiconductor data sheets and/or specifications can and do vary in different applications and actual performance may vary over time. All operating parameters, including "Typicals" must be validated for each customer application by customer's technical experts. ON Semiconductor does not convey any license under its patent rights nor the rights of others. ON Semiconductor products are not designed, intended, or authorized for use as a critical component in life support systems or any FDA Class 3 medical devices or medical devices with a same or similar classification in a foreign jurisdiction or any devices intended for implantation in the human body. Should Buyer purchase or use ON Semiconductor products for any such unintended or unauthorized application, Buyer shall indemnify and hold ON Semiconductor and its officers, employees, subsidiaries, affiliates, and distributors harmless against all claims, costs, damages, and expenses, and reasonable attorney fees arising out of, directly or indirectly, any claim of personal injury or death associated with such unintended or unauthorized use, even if such claim alleges that ON Semiconductor was negligent regarding the design or manufacture of the part. ON Semiconductor is an Equal Opportunity/Affirmative Action Employer. This literature is subject to all applicable copyright laws and is not for resale in any manner.

# FAN7527B

## Power Factor Correction Controller

### Features

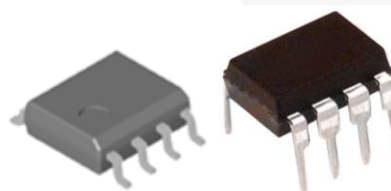
- Internal Startup Timer
- Internal R/C Filter Eliminates the Need for External R/C Filter
- Precise Adjustable Output Over-Voltage Protection
- Zero Current Detector
- One Quadrant Multiplier
- Trimmed 1.5% Internal Band Gap Reference
- Under-Voltage Lockout with 3 V of Hysteresis
- Totem-Pole Output with High-State Clamp
- Low Startup and Operating Current
- 8-Pin SOP or 8-Pin DIP

### Applications

- Electronic Ballast
- SMPS

### Description

The FAN7527B provides simple and high-performance active Power Factor Correction (PFC). The FAN7527B is optimized for electronic ballasts and low-power, high-density power supplies that require minimum board size, reduced external components, and low power dissipation. Because the R/C filter is included in the current-sense block, an external R/C filter is not necessary. Special circuitry prevents no-load runaway conditions. Regardless of the supply voltage, the output drive clamping circuit limits the overshoot of the power MOSFET gate drive, which improves system reliability.



### Ordering Information

Part Number	Operating Temperature Range	Package	Packing Method
FAN7527BMX	-25 to +125°C	8-Lead, Small Outline Package (SOP)	Tape and Reel
FAN7527BN	-25 to +125°C	8-Lead, Dual In-line Package (DIP)	Tube

Block Diagram

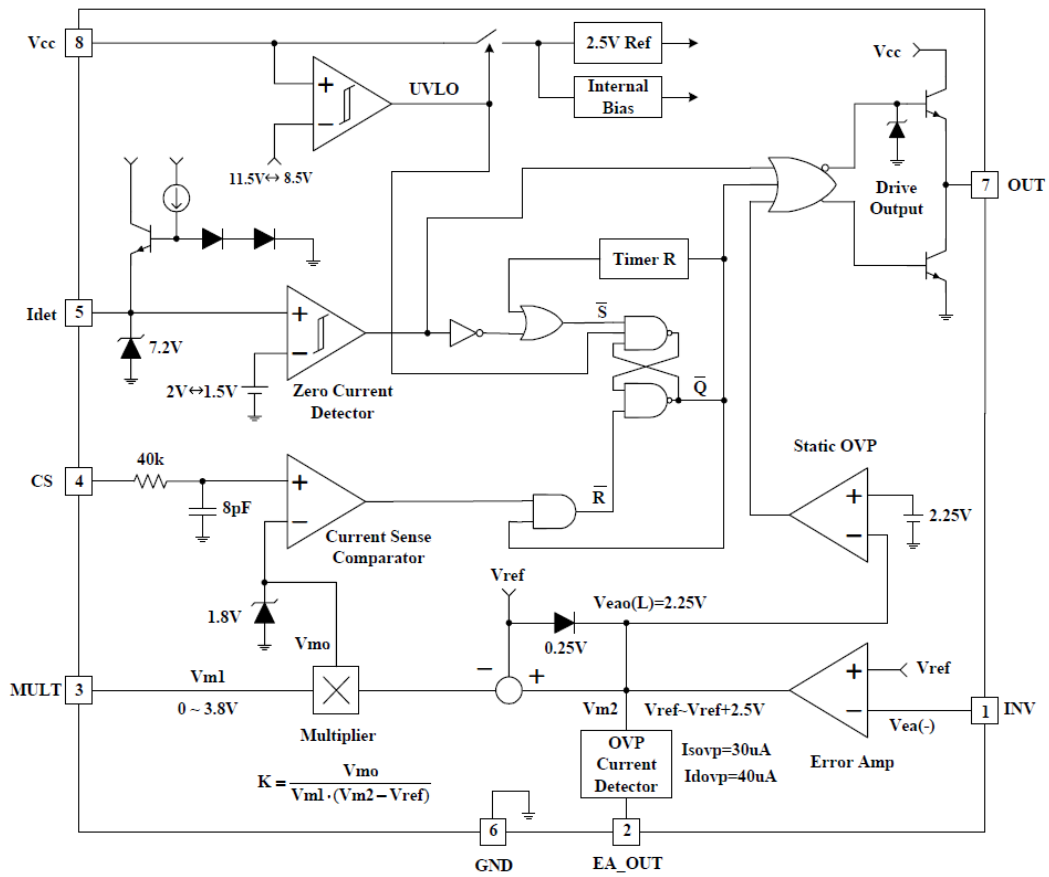


Figure 1. Block Diagram

## Pin Configuration

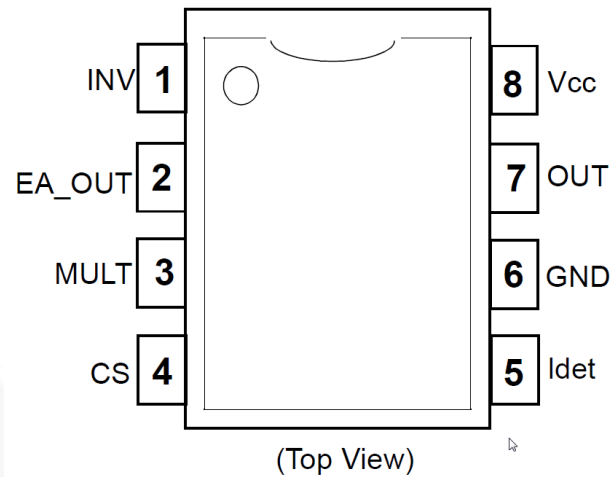


Figure 2. Pin Configuration

## Pin Definitions

Pin #	Name	Description
1	INV	Inverting input of the error amplifier. The output of the boost converter should be resistively divided to 2.5 V and connected to this pin.
2	EA_OUT	Output of the error amplifier. Feedback compensation network is placed between this pin and the INV pin.
3	MULT	Input to the multiplier stage. The full-wave rectified AC voltage is divided to less than 2 V and is connected to this pin.
4	CS	Input of the PWM comparator. The MOSFET current is sensed by a resistor and the resulting voltage is applied to this pin. An internal R/C filter is included to reject high-frequency noise.
5	Idet	Zero Current Detection (ZCD) input.
6	GND	Ground
7	OUT	Gate driver output. Push-pull output stage is able to drive the power MOSFET with a peak current of 500 mA.
8	V <sub>CC</sub>	Supply voltage of driver and control circuits.

## Absolute Maximum Ratings

Stresses exceeding the absolute maximum ratings may damage the device. The device may not function or be operable above the recommended operating conditions and stressing the parts to these levels is not recommended. In addition, extended exposure to stresses above the recommended operating conditions may affect device reliability. The absolute maximum ratings are stress ratings only.

Symbol	Parameter	Min.	Max.	Unit
$V_{CC}$	Supply Voltage		30	V
$I_{OH}, I_{OL}$	Peak Drive Output Current		$\pm 500$	mA
$I_{CLAMP}$	Driver Output Clamping Diodes $V_O > V_{CC}$ or $V_O < -0.3$ V		$\pm 10$	mA
$I_{DET}$	Detector Clamping Diodes		$\pm 10$	mA
$V_{IN}$	Error Amplifier Multiplier and Comparator Input Voltages	-0.3	6.0	V
$T_J$	Operation Junction Temperature		+150	$^{\circ}\text{C}$
$T_{OPR}$	Operating Temperature Range	-25	+125	$^{\circ}\text{C}$
$T_{STG}$	Storage Temperature Range	-65	+150	$^{\circ}\text{C}$
$P_D$	Power Dissipation	8-SOP	0.8	W
		8-DIP	1.1	W
$\Theta_{JA}$	Thermal Resistance Junction-Ambient	8-SOP	150	$^{\circ}\text{C}/\text{W}$
		8-DIP	110	$^{\circ}\text{C}/\text{W}$

## Temperature Characteristics

$-25^{\circ}\text{C} \leq T_A \leq 125^{\circ}\text{C}$ .

Symbol	Parameter	Min.	Typ.	Max.	Unit
$\Delta V_{REF}$	Temperature Stability Reference Voltage ( $V_{REF}$ )		20		mV
$\Delta K/\Delta T$	Temperature Stability for Multiplier Gain (K)		-0.2		% / $^{\circ}\text{C}$

## Electrical Characteristics

$V_{CC} = 14\text{ V}$ ,  $-25^{\circ}\text{C} \leq T_A \leq 125^{\circ}\text{C}$ , unless otherwise stated.

Symbol	Parameter	Conditions	Min.	Typ.	Max.	Unit
<b>Under-Voltage Lockout</b>						
$V_{th(st)}$	Start Threshold Voltage	$V_{CC}$ Increasing	10.5	11.5	12.5	V
$H_{Y(st)}$	UVLO Hysteresis		2	3	4	V
<b>Supply Current Section</b>						
$I_{ST}$	Startup Supply Current	$V_{CC} = V_{th(st)} - 0.2\text{ V}$	10	60	100	$\mu\text{A}$
$I_{CC}$	Operating Supply Current	Output Not Switching		3	6	mA
$I_{CC(OVP)}$	Operating Current at OVP	$V_{INV} = 3\text{ V}$		1.7	4.0	mA
$I_{DCC}$	Dynamic Operating Supply Current	50 kHz, $C_1 = 1\text{ nF}$		4	8	mA
<b>Error Amplifier Section</b>						
$V_{REF}$	Voltage Feedback Input Threshold	$I_{REF} = 0\text{ mA}$ , $T_A = 25^{\circ}\text{C}$	2.465	2.500	2.535	V
		$25^{\circ}\text{C} \leq T_A \leq 125^{\circ}\text{C}$	2.440	2.500	2.560	
$\Delta V_{FEF1}$	Line Regulation	$14\text{ V} \leq V_{CC} \leq 25\text{ V}$		0.1	10.0	mV
$\Delta V_{FEF3}$	Temperature Stability of $V_{REF}^{(1)}$	$-25^{\circ}\text{C} \leq T_A \leq 125^{\circ}\text{C}$		20		mV
$I_{b(ea)}$	Input Bias Current		-0.5		0.5	$\mu\text{A}$
$I_{SOURCE}$	Output Source Current	$V_{M2} = 4\text{ V}$	-2	-4		mA
$I_{SINK}$	Output Sink Current	$V_{M2} = 4\text{ V}$	2	4		mA
$V_{EAO(H)}$	Output Upper Clamp Voltage <sup>(1)</sup>	$I_{SOURCE} = 0.1\text{ mA}$		6		V
$V_{EAO(L)}$	Output Lower Clamp Voltage <sup>(1)</sup>	$I_{SINK} = 0.1\text{ mA}$		2.25		V
$G_V$	Large Signal Open-Loop Gain <sup>(1)</sup>		60	80		dB
PSRR	Power Supply Rejection Ratio <sup>(1)</sup>	$14\text{ V} \leq V_{CC} \leq 25\text{ V}$	60	80		dB
GBW	Unity Gain Bandwidth <sup>(1)</sup>			1		MHZ
SR	Slew Rate <sup>(1)</sup>			0.6		V/ $\mu\text{s}$
<b>Multiplier Section</b>						
$I_{b(m)}$	Input Bias Current (Pin 3)		-0.5		0.5	$\mu\text{A}$
$\Delta V_{M1}$	M1 Input Voltage Range (Pin 3)				3.8	V
$\Delta V_{M2}$	M2 Input Voltage Range (Pin 2)		$V_{REF}$		$V_{REF} + 2.5$	V
K	Multiplier Gain <sup>(1)</sup>	$V_{M1} = 1\text{ V}$ , $V_{M2} = 3.5\text{ V}$	0.36	0.44	0.52	1 / V
$V_{OMAX(m)}$	Maximum Multiplier Output Voltage	$V_{INV} = 0\text{ V}$ , $V_{M1} = 4\text{ V}$	1.65	1.80	1.95	V
$\Delta K/\Delta T$	Temperature Stability of K <sup>(1)</sup>	$-25 \leq T_A \leq 125^{\circ}\text{C}$		-0.2		% / $^{\circ}\text{C}$
<b>Current Sense Section</b>						
$V_{IO(CS)}$	Input Offset Voltage <sup>(1)</sup>	$V_{M1} = 0\text{ V}$ , $V_{M2} = 2.2\text{ V}$	-10	3	10	mV
$I_{b(CS)}$	Input Bias Current	$0\text{ V} \leq V_{CS} \leq 1.7\text{ V}$	-1.0	-0.1	1.0	$\mu\text{A}$
$t_{D(CS)}$	Current Sense Delay to Output <sup>(1)</sup>			200	500	ns

Continued on the following page...

**Electrical Characteristics** (Continued)

$V_{CC} = 14\text{ V}$ ,  $-25^{\circ}\text{C} \leq T_A \leq 125^{\circ}\text{C}$ , unless otherwise stated.

Symbol	Parameter	Conditions	Min.	Typ.	Max.	Unit
<b>Zero Current Detect Section</b>						
$V_{TH(DET)}$	Input Voltage Threshold	$V_{DET}$ Increasing	1.7	2.0	2.3	V
$H_{Y(DET)}$	Detect Hysteresis		0.2	0.5	0.8	V
$V_{CLAMP(L)}$	Input Low Clamp Voltage	$I_{DET} = -100\ \mu\text{A}$	0.45	0.75	1.00	V
$V_{CLAMP(H)}$	Input High Clamp Voltage	$I_{DET} = 3\ \text{mA}$	6.5	7.2	7.9	V
$I_{b(DET)}$	Input Bias Current	$1\ \text{V} \leq V_{DET} \leq 5\ \text{V}$	-1.0	-0.1	1.0	$\mu\text{A}$
$I_{CLAMP(D)}$	Input High/Low Clamp Diode Current <sup>(1)</sup>				$\pm 3$	mA
<b>Output Section</b>						
$V_{OH}$	Output Voltage High	$I_O = -10\ \text{mA}$	10.5	11.0		V
$V_{OL}$	Output Voltage Low	$I_O = 10\ \text{mA}$		0.8	1.0	V
$t_R$	Rising Time <sup>(1)</sup>	$C_L = 1\ \text{nF}$		130	200	ns
$t_F$	Falling Time <sup>(1)</sup>	$C_L = 1\ \text{nF}$		50	120	ns
$V_{OMAX(O)}$	Maximum Output Voltage	$V_{CC} = 20\ \text{V}$ , $I_O = 100\ \mu\text{A}$	12	14	16	V
$V_{OMIN(O)}$	Output Voltage with UVLO Activated	$V_{CC} = 5\ \text{V}$ , $I_O = 100\ \mu\text{A}$			1	V
<b>Restart Timer Section</b>						
$t_{D(RST)}$	Restart Time Delay	$V_{M1} = 1\ \text{V}$ , $V_{M2} = 3.5\ \text{V}$		150		$\mu\text{s}$
<b>Over-Voltage Protection Section</b>						
$I_{SOVP}$	Soft OVP Detecting Current		25	30	35	$\mu\text{A}$
$I_{DOVP}$	Dynamic OVP Detecting Current		35	40	45	$\mu\text{A}$
$V_{OVP}$	Static OVP Threshold Voltage	$V_{INV} = 2.7\ \text{V}$	2.10	2.25	2.40	V

**Note:**

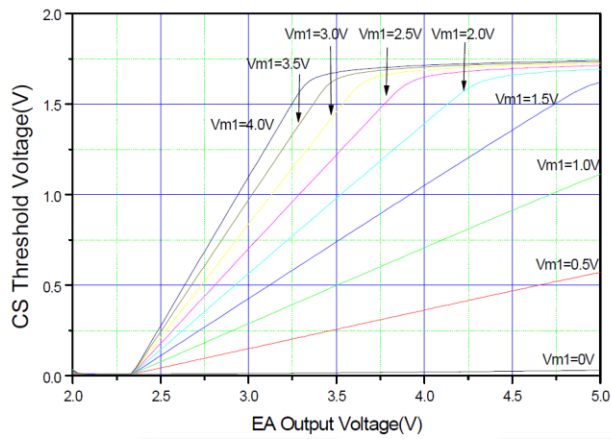
- These parameters, although guaranteed, are not 100% tested in production.

Multiplier Gain:

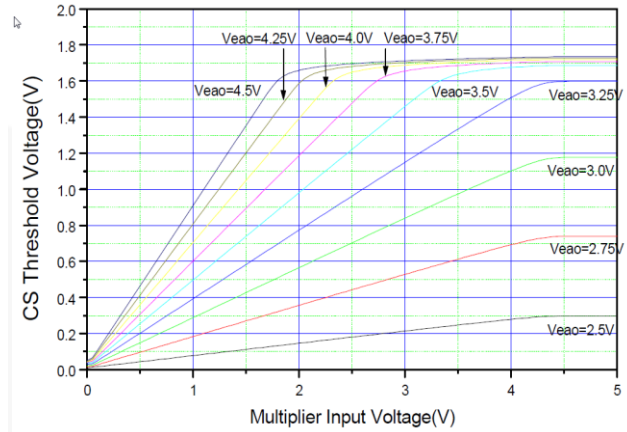
$$K = \frac{Pin4\_Threshold}{V_{M1} \times (V_{M2} - V_{REF})}$$

where  $V_{M1} = V_{PIN3}$ ,  $V_{M2} = V_{PIN2}$

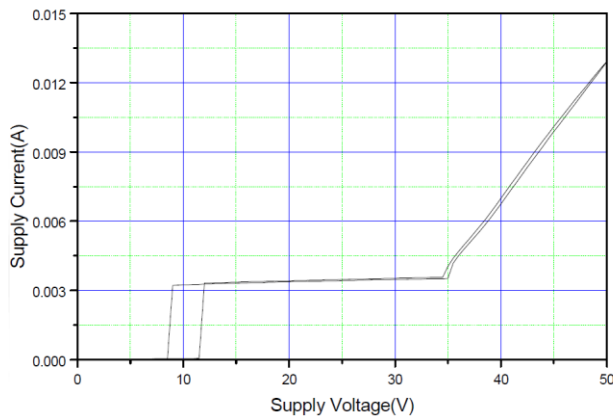
## Typical Performance Characteristics



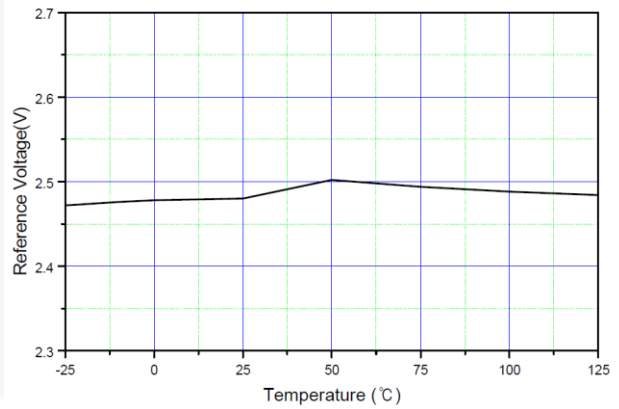
**Figure 3. Error Amplifier Output Voltage vs. Current Sensing Threshold**



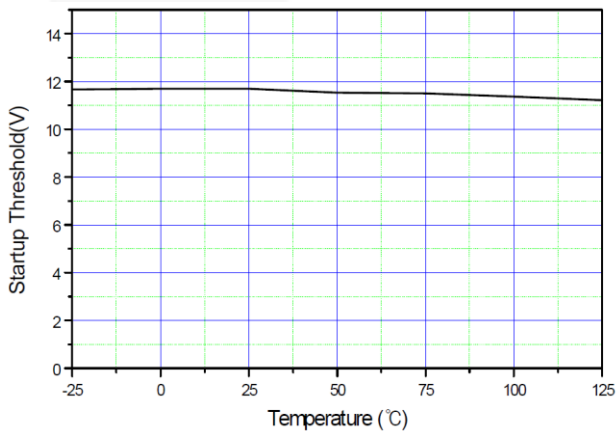
**Figure 4. Multiplier Input Voltage vs. Current Sensing Threshold**



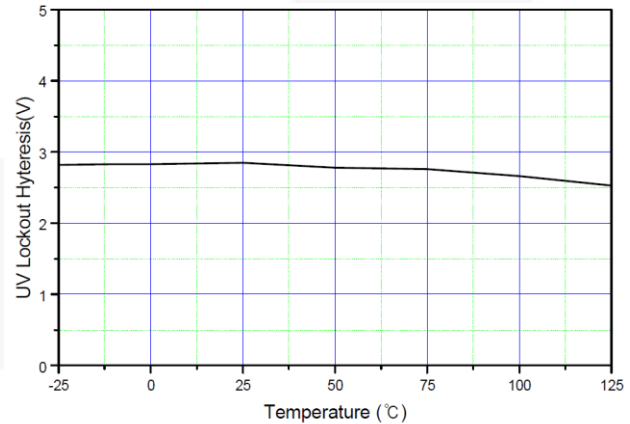
**Figure 5. Supply Current vs. Supply Voltage**



**Figure 6. Reference Voltage vs. Temperature**

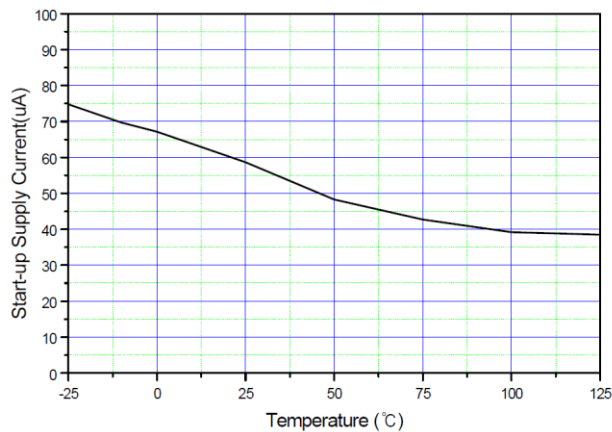


**Figure 7. Startup Threshold vs. Temperature**

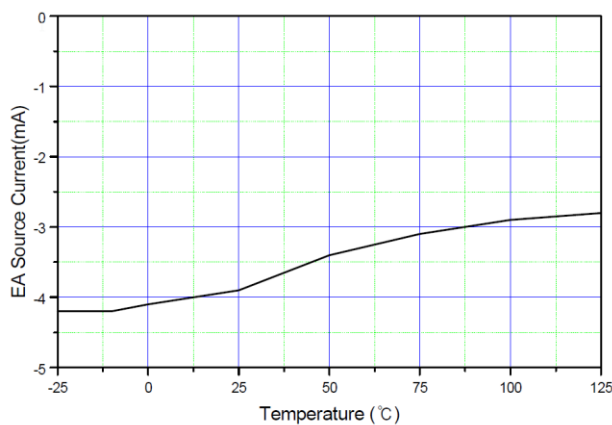


**Figure 8. UVLO Hysteresis vs. Temperature**

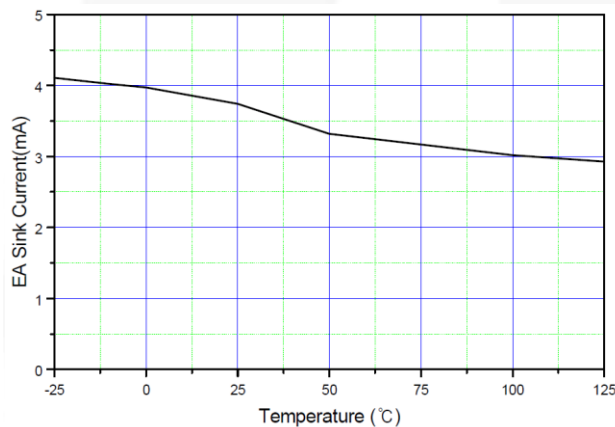
**Typical Performance Characteristics (Continued)**



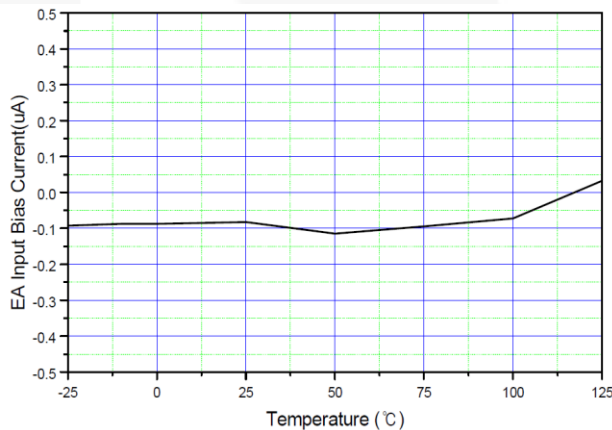
**Figure 9. Startup Supply Current vs. Temperature**



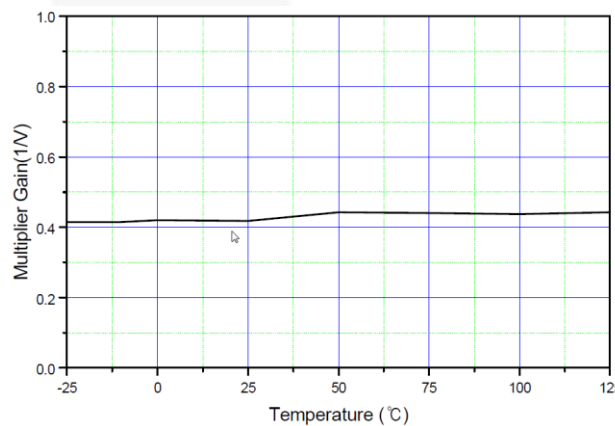
**Figure 10. Error Amplifier Source Current**



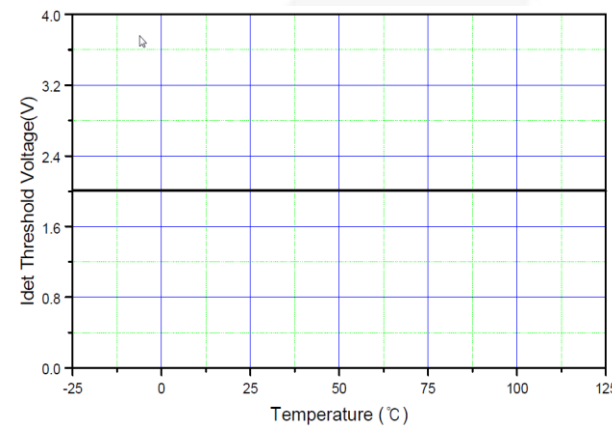
**Figure 11. Error Amplifier Sink Current vs. Temperature**



**Figure 12. Error Amplifier Input Bias Current vs. Temperature**

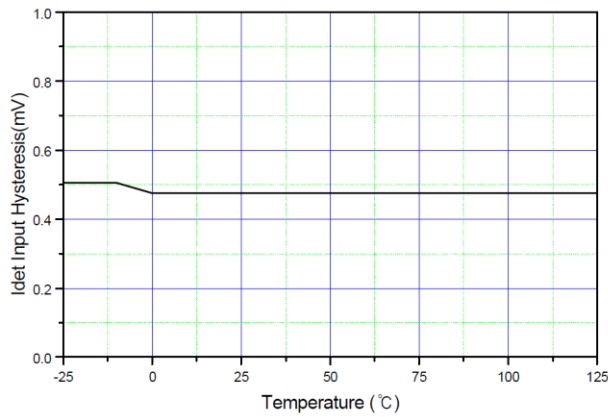


**Figure 13. Multiplier Gain vs. Temperature**

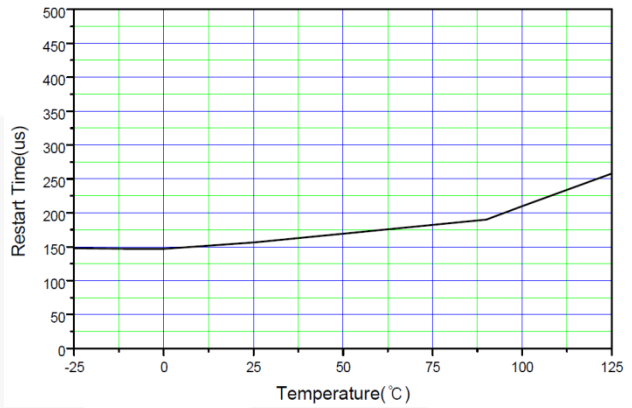


**Figure 14. I<sub>DET</sub> Threshold Voltage vs. Threshold**

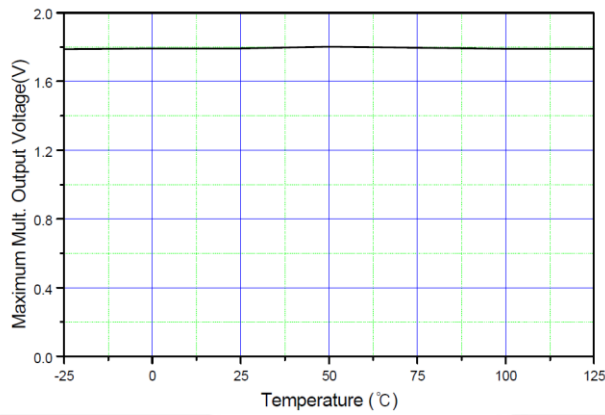
**Typical Performance Characteristics** (Continued)



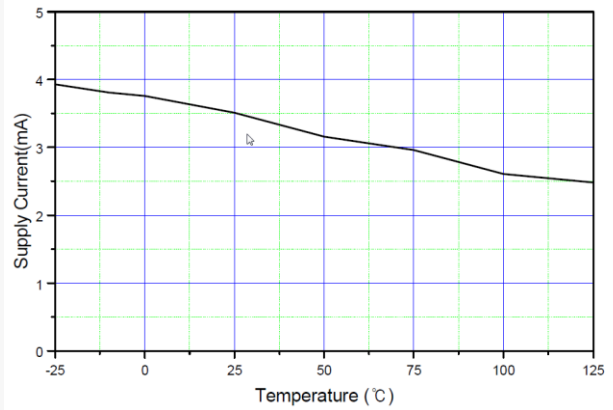
**Figure 15. IDET Input Hysteresis vs. Temperature**



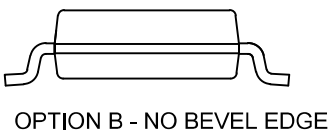
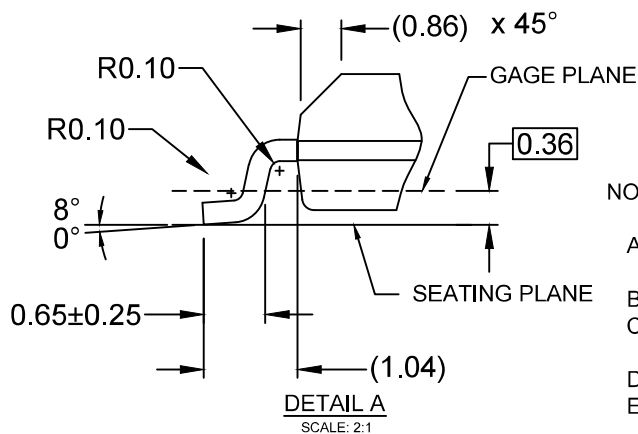
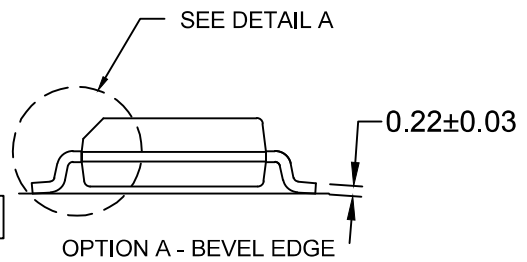
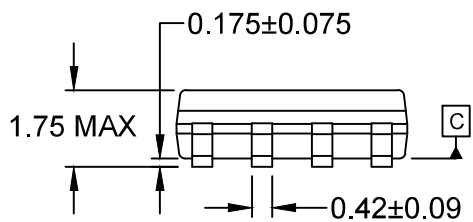
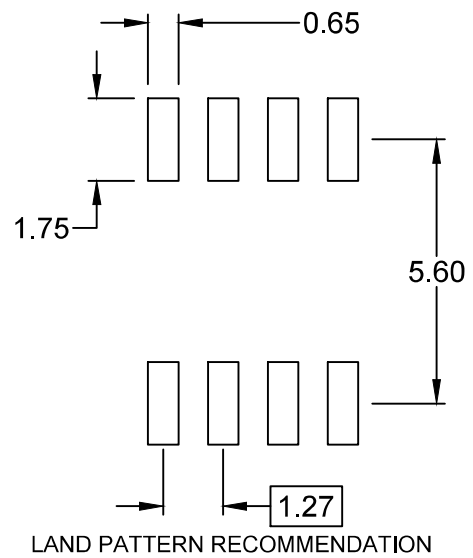
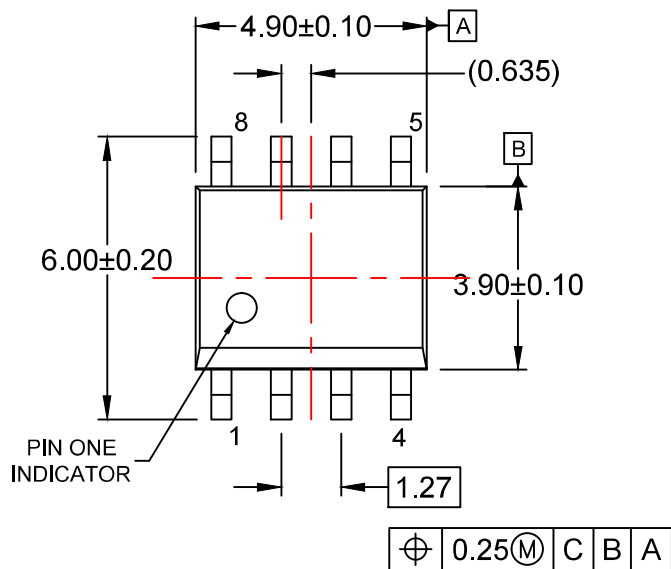
**Figure 16. Restart Time vs. Temperature**



**Figure 17. Maximum Multiplier Output Voltage vs. Temperature**



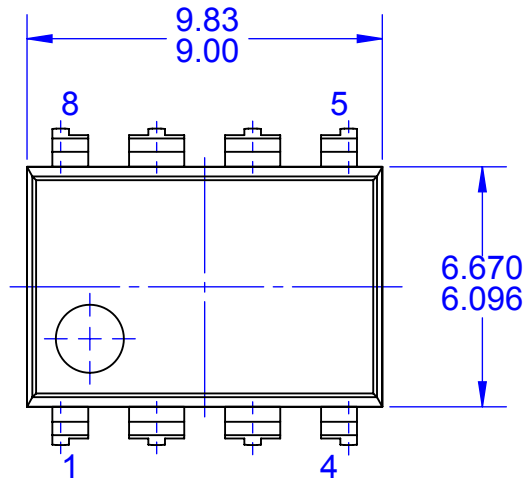
**Figure 18. Supply Current vs. Temperature**



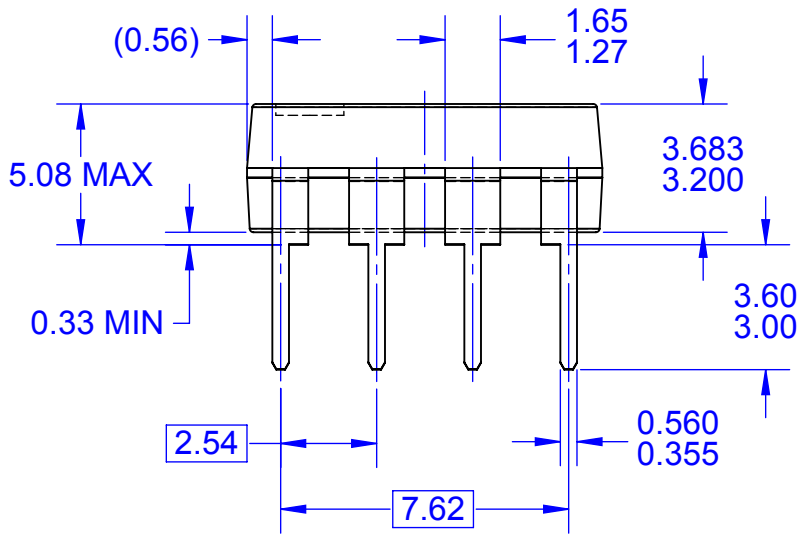
NOTES:

- A) THIS PACKAGE CONFORMS TO JEDEC MS-012, VARIATION AA.
- B) ALL DIMENSIONS ARE IN MILLIMETERS.
- C) DIMENSIONS DO NOT INCLUDE MOLD FLASH OR BURRS.
- D) LANDPATTERN STANDARD: SOIC127P600X175-8M
- E) DRAWING FILENAME: M08Arev16

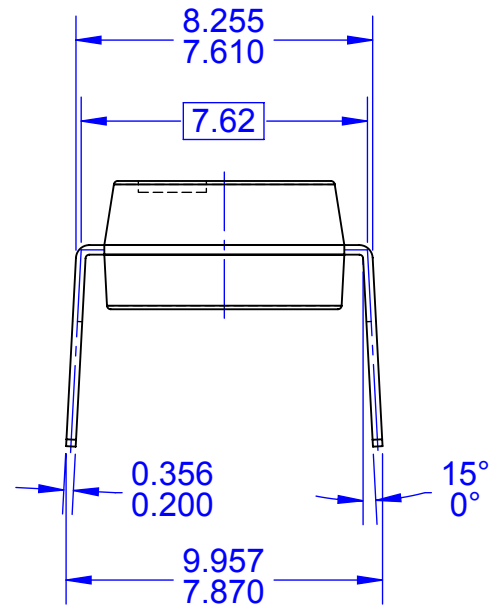




TOP VIEW



FRONT VIEW



SIDE VIEW

NOTES:

- A. CONFORMS TO JEDEC MS-001, VARIATION BA
- B. ALL DIMENSIONS ARE IN MILLIMETERS
- C. DIMENSIONS ARE EXCLUSIVE OF BURRS, MOLD FLASH, AND TIE BAR EXTRUSIONS
- D. DIMENSIONS AND TOLERANCES PER ASME Y14.5M-2009
- E. DRAWING FILENAME: MKT-N08Frev3



ON Semiconductor and  are trademarks of Semiconductor Components Industries, LLC dba ON Semiconductor or its subsidiaries in the United States and/or other countries. ON Semiconductor owns the rights to a number of patents, trademarks, copyrights, trade secrets, and other intellectual property. A listing of ON Semiconductor's product/patent coverage may be accessed at [www.onsemi.com/site/pdf/Patent-Marking.pdf](http://www.onsemi.com/site/pdf/Patent-Marking.pdf). ON Semiconductor reserves the right to make changes without further notice to any products herein. ON Semiconductor makes no warranty, representation or guarantee regarding the suitability of its products for any particular purpose, nor does ON Semiconductor assume any liability arising out of the application or use of any product or circuit, and specifically disclaims any and all liability, including without limitation special, consequential or incidental damages. Buyer is responsible for its products and applications using ON Semiconductor products, including compliance with all laws, regulations and safety requirements or standards, regardless of any support or applications information provided by ON Semiconductor. "Typical" parameters which may be provided in ON Semiconductor data sheets and/or specifications can and do vary in different applications and actual performance may vary over time. All operating parameters, including "Typicals" must be validated for each customer application by customer's technical experts. ON Semiconductor does not convey any license under its patent rights nor the rights of others. ON Semiconductor products are not designed, intended, or authorized for use as a critical component in life support systems or any FDA Class 3 medical devices or medical devices with a same or similar classification in a foreign jurisdiction or any devices intended for implantation in the human body. Should Buyer purchase or use ON Semiconductor products for any such unintended or unauthorized application, Buyer shall indemnify and hold ON Semiconductor and its officers, employees, subsidiaries, affiliates, and distributors harmless against all claims, costs, damages, and expenses, and reasonable attorney fees arising out of, directly or indirectly, any claim of personal injury or death associated with such unintended or unauthorized use, even if such claim alleges that ON Semiconductor was negligent regarding the design or manufacture of the part. ON Semiconductor is an Equal Opportunity/Affirmative Action Employer. This literature is subject to all applicable copyright laws and is not for resale in any manner.

## PUBLICATION ORDERING INFORMATION

### LITERATURE FULFILLMENT:

Literature Distribution Center for ON Semiconductor  
19521 E. 32nd Pkwy, Aurora, Colorado 80011 USA  
**Phone:** 303-675-2175 or 800-344-3860 Toll Free USA/Canada  
**Fax:** 303-675-2176 or 800-344-3867 Toll Free USA/Canada  
**Email:** [orderlit@onsemi.com](mailto:orderlit@onsemi.com)

**N. American Technical Support:** 800-282-9855 Toll Free  
USA/Canada  
**Europe, Middle East and Africa Technical Support:**  
Phone: 421 33 790 2910  
**Japan Customer Focus Center**  
Phone: 81-3-5817-1050

**ON Semiconductor Website:** [www.onsemi.com](http://www.onsemi.com)  
**Order Literature:** <http://www.onsemi.com/orderlit>  
For additional information, please contact your local  
Sales Representative

## Looking for pricing, stock, or lifecycle information?

Click below to explore more details on WIN SOURCE:

- ⊖ [View FAN7527BMX on WIN SOURCE](#)
- ⊖ [Fairchild/ON Semiconductor Information](#)

## Optimize Your Supply Chain with WIN SOURCE Solutions

- ✓ Global Sourcing Solution
- ✓ Obsolete Management
- ✓ Cost Control Management
- ✓ Shortage Management
- ✓ Alternative Solution
- ✓ Excess Inventory Management