



Is Now Part of



ON Semiconductor®

To learn more about ON Semiconductor, please visit our website at
www.onsemi.com

Please note: As part of the Fairchild Semiconductor integration, some of the Fairchild orderable part numbers will need to change in order to meet ON Semiconductor's system requirements. Since the ON Semiconductor product management systems do not have the ability to manage part nomenclature that utilizes an underscore (_), the underscore (_) in the Fairchild part numbers will be changed to a dash (-). This document may contain device numbers with an underscore (_). Please check the ON Semiconductor website to verify the updated device numbers. The most current and up-to-date ordering information can be found at www.onsemi.com. Please email any questions regarding the system integration to Fairchild_questions@onsemi.com.

ON Semiconductor and the ON Semiconductor logo are trademarks of Semiconductor Components Industries, LLC dba ON Semiconductor or its subsidiaries in the United States and/or other countries. ON Semiconductor owns the rights to a number of patents, trademarks, copyrights, trade secrets, and other intellectual property. A listing of ON Semiconductor's product/patent coverage may be accessed at www.onsemi.com/site/pdf/Patent-Marking.pdf. ON Semiconductor reserves the right to make changes without further notice to any products herein. ON Semiconductor makes no warranty, representation or guarantee regarding the suitability of its products for any particular purpose, nor does ON Semiconductor assume any liability arising out of the application or use of any product or circuit, and specifically disclaims any and all liability, including without limitation special, consequential or incidental damages. Buyer is responsible for its products and applications using ON Semiconductor products, including compliance with all laws, regulations and safety requirements or standards, regardless of any support or applications information provided by ON Semiconductor. "Typical" parameters which may be provided in ON Semiconductor data sheets and/or specifications can and do vary in different applications and actual performance may vary over time. All operating parameters, including "Typicals" must be validated for each customer application by customer's technical experts. ON Semiconductor does not convey any license under its patent rights nor the rights of others. ON Semiconductor products are not designed, intended, or authorized for use as a critical component in life support systems or any FDA Class 3 medical devices or medical devices with a same or similar classification in a foreign jurisdiction or any devices intended for implantation in the human body. Should Buyer purchase or use ON Semiconductor products for any such unintended or unauthorized application, Buyer shall indemnify and hold ON Semiconductor and its officers, employees, subsidiaries, affiliates, and distributors harmless against all claims, costs, damages, and expenses, and reasonable attorney fees arising out of, directly or indirectly, any claim of personal injury or death associated with such unintended or unauthorized use, even if such claim alleges that ON Semiconductor was negligent regarding the design or manufacture of the part. ON Semiconductor is an Equal Opportunity/Affirmative Action Employer. This literature is subject to all applicable copyright laws and is not for resale in any manner.

FAN7384

Half-Bridge Gate-Drive IC

Features

- Floating Channel for Bootstrap Operation to +600V
- Typically 250mA/500mA Sourcing/Sinking Current Driving Capability for Both Channels
- Extended Allowable Negative V_S Swing to -9.8V for Signal Propagation at $V_{DD}=V_{BS}=15V$
- Matched Propagation Delay Below 50ns
- Output In-Phase with Input Signal
- 3.3V and 5V Input Logic Compatible
- Built-in Shoot-Through Prevention Logic
- Built-in Common Mode dv/dt Noise Canceling Circuit
- Built-in UVLO Functions for Both Channels
- Built-in Cycle-by-Cycle Shutdown Function
- Built-in Soft-Off Function
- Built-in Bi-Directional Fault Function
- Built-in Short-Circuit Protection Function

Applications

- Motor Inverter Driver
- Normal Half-Bridge and Full-Bridge Driver
- Switching Mode Power Supply

Description

The FAN7384 is a monolithic half-bridge gate-drive IC designed for high voltage, high speed driving MOSFETs and IGBTs operating up to +600V.

Fairchild's high-voltage process and common-mode noise canceling technique provide stable operation of high-side drivers under high-dv/dt noise circumstances.

An advanced level-shift circuit allows high-side gate driver operation up to $V_S = -9.8V$ (typical) for $V_{BS} = 15V$.

The UVLO circuits prevent malfunction when V_{DD} and V_{BS} are lower than the specified threshold voltage.

Output drivers typically source/sink 250mA/500mA, respectively, which is suitable for half-bridge and full-bridge applications in motor drive systems.

14-SOP

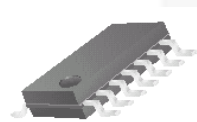

Ordering Information

Part Number	Package	Operating Temperature Range	Packing Method
FAN7384MX ⁽¹⁾	14-Lead, Small Outline Integrated Circuit (SOIC), Non-JEDEC, .150 Inch Narrow Body, 225SOP	-40°C to +125°C	Tape & Reel

Note:

1. The device passed wave soldering test by JESD22A-111.

Typical Application Diagrams

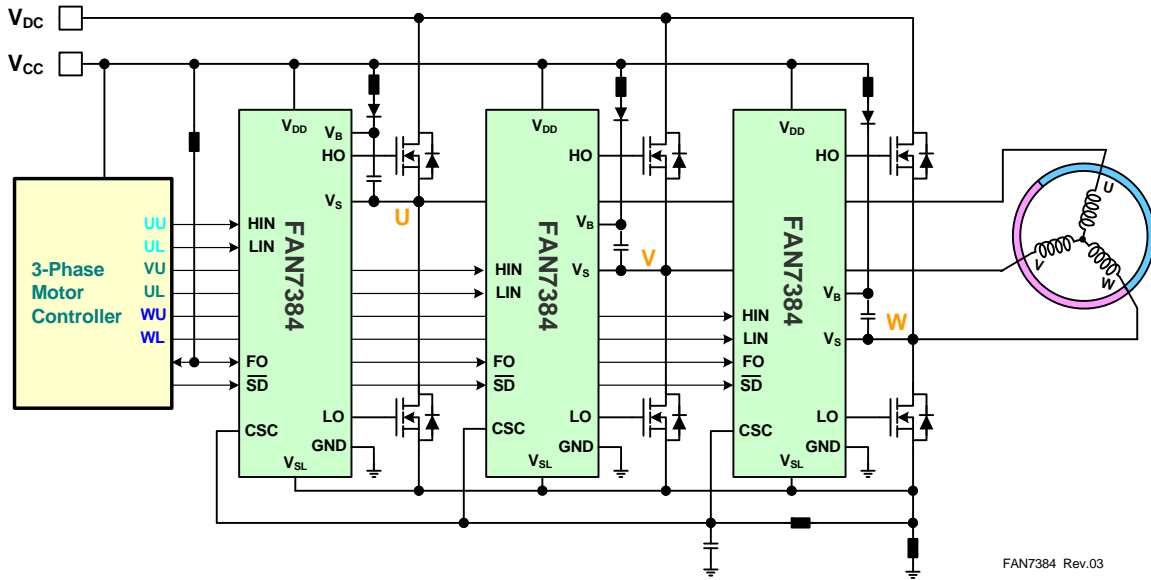

FAN7384 Rev.03

Figure 1. 3-Phase Motor Drive Application

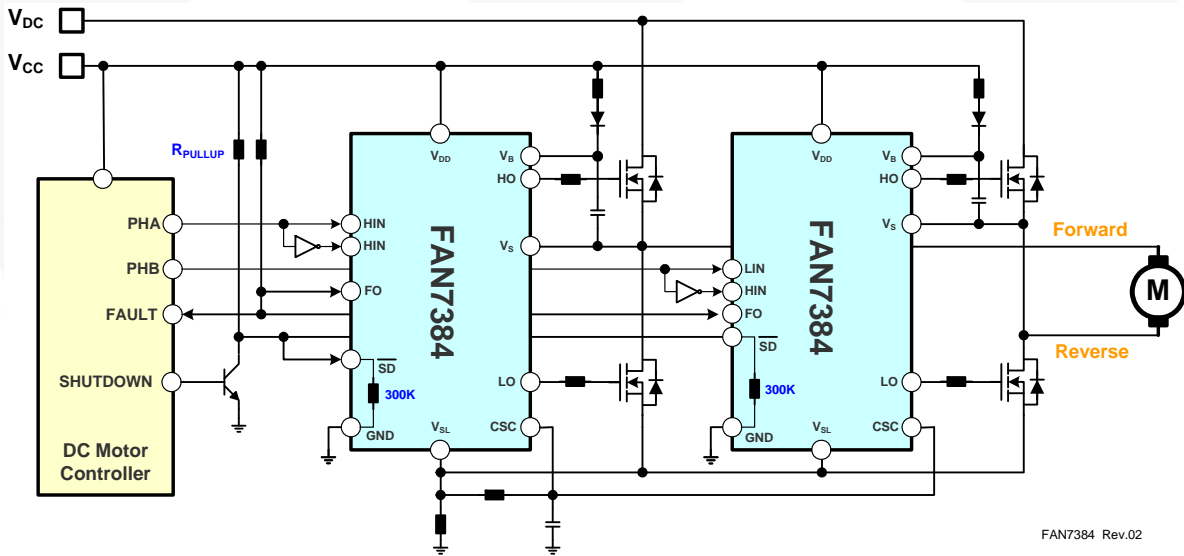

FAN7384 Rev.02

Figure 2. DC Motor Drive Application

Internal Block Diagram

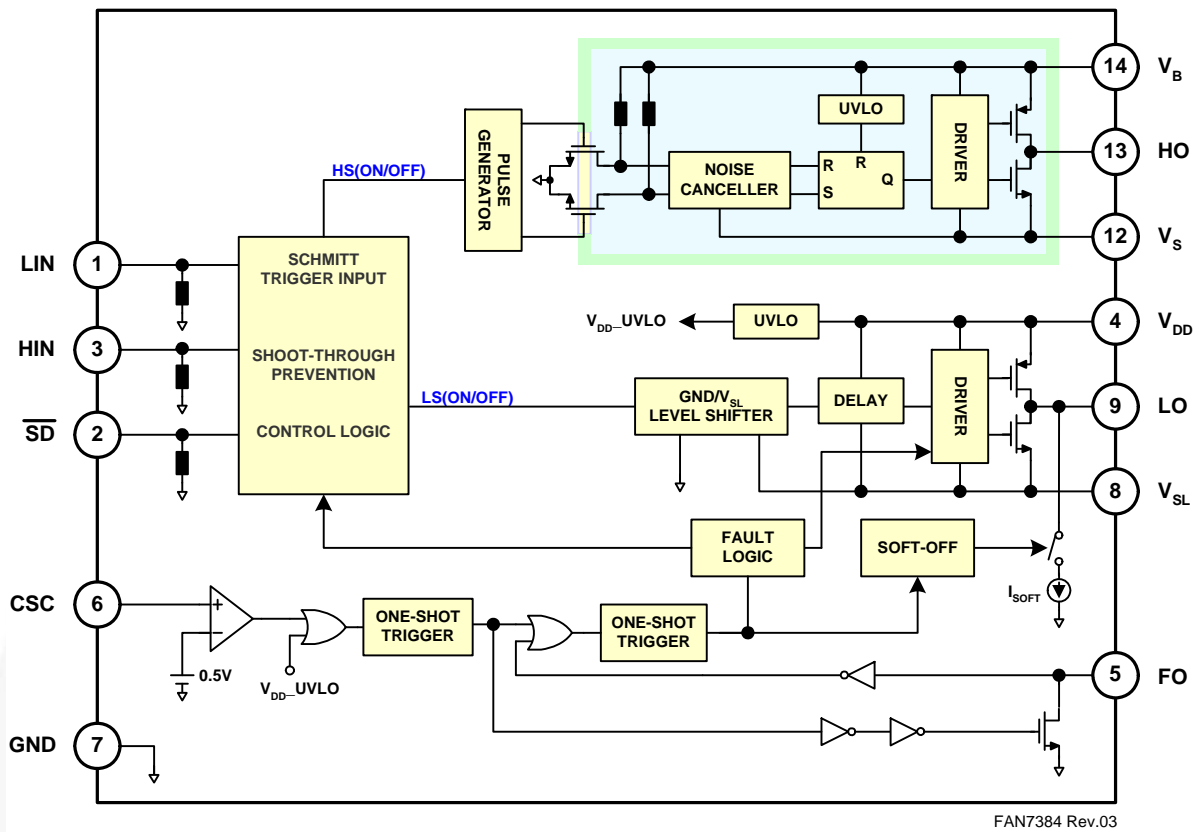

Figure 3. Functional Block Diagram

Pin Configuration

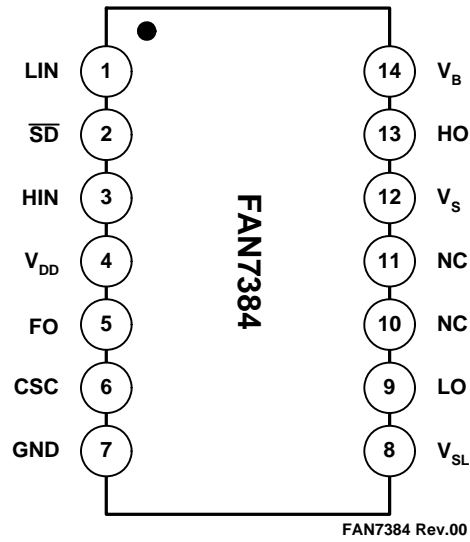

Figure 4. Pin Configuration (Top View)

Pin Definitions

Pin #	Name	Description
1	LIN	Logic Input for low-side gate driver
2	$\overline{\text{SD}}$	Shutdown control input with active low
3	HIN	Logic Input for high-side gate driver
4	V_{DD}	Low-side power supply voltage
5	FO	Bi-direction fault pin with open drain
6	CSC	Short-circuit current detection input
7	GND	Ground
8	V_{SL}	Low-side supply offset voltage
9	LO	Low-side gate driver output
10	NC	Not connection
11	NC	Not connection
12	V_{S}	High-side floating supply offset voltage
13	HO	High-side gate driver output
14	V_{B}	High-side floating supply voltage

Absolute Maximum Ratings

Stresses exceeding the absolute maximum ratings may damage the device. The device may not function or be operable above the recommended operating conditions and stressing the parts to these levels is not recommended. In addition, extended exposure to stresses above the recommended operating conditions may affect device reliability. The absolute maximum ratings are stress ratings only. $T_A=25^{\circ}\text{C}$, unless otherwise specified.

Symbol	Parameter	Min.	Max.	Unit
V_S	High-side offset voltage V_S	V_B-25	$V_B+0.3$	V
V_B	High-side floating supply voltage V_B	-0.3	625	V
V_{HO}	High-side floating output voltage	$V_S-0.3$	$V_B+0.3$	V
V_{DD}	Low-side and logic-fixed supply voltage	-0.3	25	V
V_{IN}	Logic input voltage (HIN, LIN, \overline{SD})	-0.3	$V_{DD}+0.3$	V
V_{CSC}	Current sense input voltage	-0.3	$V_{DD}+0.3$	V
V_{FO}	Fault output voltage	-0.3	$V_{DD}+0.3$	V
dV_S/dt	Allowable offset voltage slew rate		50	V/ns
$P_D^{(2)(3)(4)}$	Power dissipation		1.0	W
θ_{JA}	Thermal resistance, junction-to-ambient		110	$^{\circ}\text{C}/\text{W}$
T_J	Junction temperature		+150	$^{\circ}\text{C}$
T_S	Storage temperature	-55	+150	$^{\circ}\text{C}$

Notes:

- Mounted on 76.2 x 114.3 x 1.6mm PCB (FR-4 glass epoxy material).
- Refer to the following standards:
 - JESD51-2: Integral circuits thermal test method environmental conditions - natural convection
 - JESD51-3: Low effective thermal conductivity test board for leaded surface mount packages
- Do not exceed P_D under any circumstances.

Recommended Operating Conditions

The Recommended Operating Conditions table defines the conditions for actual device operation. Recommended operating conditions are specified to ensure optimal performance to the datasheet specifications. Fairchild does not recommend exceeding them or designing to Absolute Maximum Ratings.

Symbol	Parameter	Condition	Min.	Max.	Unit
V_B	High-side floating supply voltage		V_S+13	V_S+20	V
V_S	High-side floating supply offset voltage		$6-V_{DD}$	600	V
V_{DD}	Supply voltage		13	20	V
V_{HO}	High-side output voltage		V_S	V_B	V
V_{LO}	Low-side output voltage		GND	V_{DD}	V
V_{IN}	Logic input voltage (HIN, LIN, \overline{SD})		GND	V_{DD}	V
V_{FO}	Fault output voltage		-0.3	$V_{DD}+0.3$	V
T_A	Ambient temperature		-40	+125	$^{\circ}\text{C}$

Electrical Characteristics

V_{BIAS} (V_{DD} , V_{BS}) = 15.0V, T_A = 25°C, unless otherwise specified. The V_{IN} and I_{IN} parameters are referenced to GND. The V_O and I_O parameters are referenced to V_S and GND and are applicable to the respective outputs HO and LO.

Symbol	Characteristics	Condition	Min.	Typ.	Max.	Unit
LOW SIDE POWER SUPPLY SECTION						
I_{QDD}	Quiescent V_{DD} supply current	$V_{LIN}=0V$ or 5V		600	800	μA
I_{PDD}	Operating V_{DD} supply current	$f_{LIN}=20kHz$, rms value		950	1300	μA
V_{DDUV+}	V_{DD} supply under-voltage positive going threshold	$V_{DD}=\text{Sweep}$	10.9	11.9	12.9	V
V_{DDUV-}	V_{DD} supply under-voltage negative going threshold	$V_{DD}=\text{Sweep}$	10.4	11.4	12.4	V
V_{DDHYS}	V_{DD} supply under-voltage lockout hysteresis	$V_{DD}=\text{Sweep}$		0.5		V
BOOTSTRAPPED POWER SUPPLY SECTION						
V_{BSUV+}	V_{BS} supply under-voltage positive going threshold	$V_{BS}=\text{Sweep}$	10.6	11.5	12.4	V
V_{BSUV-}	V_{BS} supply under-voltage negative going threshold	$V_{BS}=\text{Sweep}$	10.1	11.0	11.9	V
V_{BSHYS}	V_{BS} supply under-voltage lockout hysteresis	$V_{BS}=\text{Sweep}$		0.5		V
I_{LK}	Offset supply leakage current	$V_B=V_S=600V$			10	μA
I_{QBS}	Quiescent V_{BS} supply current	$V_{HIN}=0V$ or 5V		50	90	μA
I_{PBS}	Operating V_{BS} supply current	$f_{HIN}=20kHz$, rms value		400	600	μA
GATE DRIVER OUTPUT SECTION						
V_{OH}	High-level output voltage, $V_{BIAS}-V_O$	$I_O=0mA$ (No Load)			100	mV
V_{OL}	Low-level output voltage, V_O	$I_O=0mA$ (No Load)			100	mV
I_{O+}	Output HIGH short-circuit pulse current	$V_O=0V$, $V_{IN}=5V$ with $PW<10\mu s$	200	250		mA
I_{O-}	Output LOW short-circuit pulsed current	$V_O=15V$, $V_{IN}=0V$ with $PW<10\mu s$	420	500		mA
V_S	Allowable negative V_S pin voltage for IN signal propagation to H_O			-9.8	-7.0	V
V_{SL-GND}	$V_{SL-GND}/GND-V_{SL}$ voltage endurance		-7.0		7.0	V
SHUTDOWN CONTROL SECTION (SD)						
$\overline{SD+}$	Shutdown "1" input voltage				1.2	V
$\overline{SD-}$	Shutdown "0" input voltage		2.5			V
LOGIC INPUT SECTION (HIN, LIN)						
V_{IH}	Logic "1" input voltage		2.5			V
V_{IL}	Logic "0" input voltage				1.2	V
V_{INHYS}	Logic input hysteresis voltage			0.5		V
I_{IN+}	Logic "1" input bias current	$V_{IN}=5V$	10	15	20	μA
I_{IN-}	Logic "0" input bias current	$V_{IN}=0V$			2.0	μA

Electrical Characteristics (Continued)

V_{BIAS} (V_{DD} , V_{BS}) = 15.0V, T_A = 25°C, unless otherwise specified. The V_{IN} and I_{IN} parameters are referenced to GND. The V_O and I_O parameters are referenced to GND and V_S is applicable to HO and LO.

Symbol	Characteristics	Condition	Min.	Typ.	Max.	Unit
SHORT-CIRCUIT PROTECTION						
V_{CSCREF}	Short-circuit detector reference voltage		0.47	0.50	0.53	V
I_{CSCIN}	Short-circuit input current	$V_{CSCIN}=1V$, $R_{CSCIN}=100K\Omega$	5	10	15	μA
I_{SOFT}	Soft turn-off source current	$V_{DD}=15V$	5	10	15	mA
$-V_{CSC}$	Negative CSC pin immunity ⁽⁵⁾	Voltage on CSC pin up to -12V, Time<2 μs			-20	V
FAULT DETECTION SECTION						
V_{FINH}	Fault input high level voltage		2.5			V
V_{FINL}	Fault input low level voltage				1.2	V
V_{FINHYS}	Fault input hysteresis voltage ⁽⁵⁾			0.5		V
V_{FOH}	Fault output high level voltage	$V_{CSC}=0V$, $R_{PULL-UP}=4.7K\Omega$	4.7			V
V_{FOL}	Fault output low level voltage	$V_{CSC}=1V$, $I_{FO}=2mA$			0.8	V
t_{FO}	Fault output pulse width	$V_{CSCIN}=1V$		60	100	μs

Note:

5. These parameters guaranteed by design.

Dynamic Electrical Characteristics

$T_A=25^\circ C$, V_{BIAS} (V_{DD} , V_{BS}) = 15.0V, V_S = GND, C_{Load} = 1000pF unless otherwise specified.

Symbol	Parameter	Conditions	Min.	Typ.	Max.	Unit
t_{on}	Turn-on propagation delay	$V_S=0V$		180	260	ns
t_{off}	Turn-off propagation delay	$V_S=0V$ or 600V ⁽⁵⁾		170	240	ns
t_r	Turn-on rise time			50	100	ns
t_f	Turn-off fall time			30	80	ns
MT	Delay matching				50	ns
DT	Dead-time		80	120	170	ns
t_{UVFLT}	Under-voltage filtering time ⁽⁵⁾			16		μs
t_{CSCFLT}	CSC pin filtering time ⁽⁵⁾			300		ns
t_{CSCFO}	Time from CSC triggering to FO ⁽⁵⁾			350		ns
t_{CSCLO}	Time from CSC triggering to low-side gate output ⁽⁵⁾	From $V_{CSC}=1V$ to starting gate turn-off		600		ns
t_{SDFO}	Shutdown to FO propagation delay ⁽⁵⁾			60		ns
t_{SDOFF}	Shutdown to HIGH/LOW-side gate off ⁽⁵⁾			100		ns

Note:

5. These parameters guaranteed by design.

Typical Characteristics

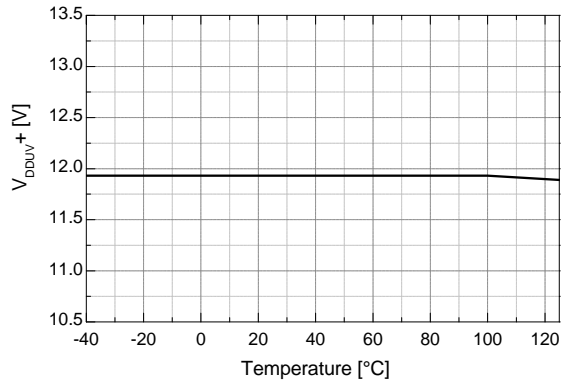

Figure 5. $V_{DD} UVLO (+)$ vs. Temperature

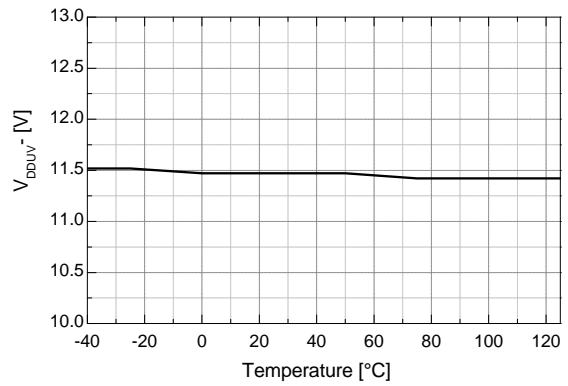

Figure 6. $V_{DD} UVLO (-)$ vs. Temperature

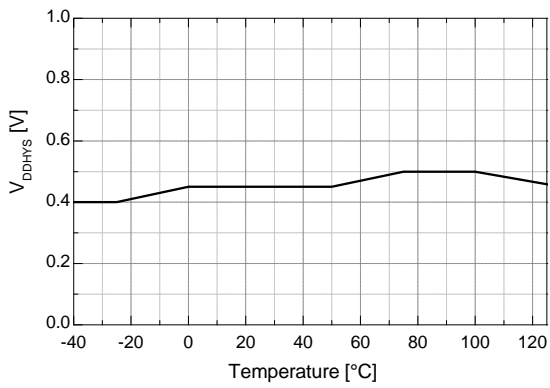

Figure 7. $V_{DD} UVLO$ Hysteresis vs. Temperature

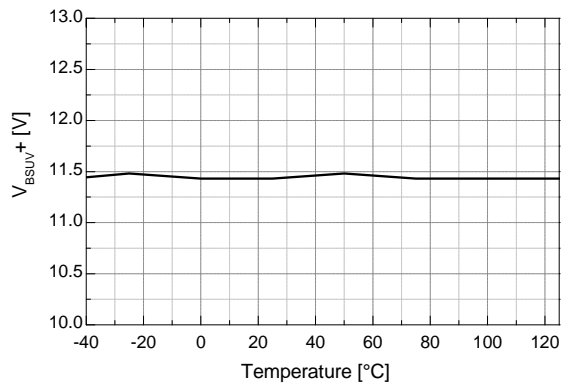

Figure 8. $V_{BS} UVLO (+)$ vs. Temperature

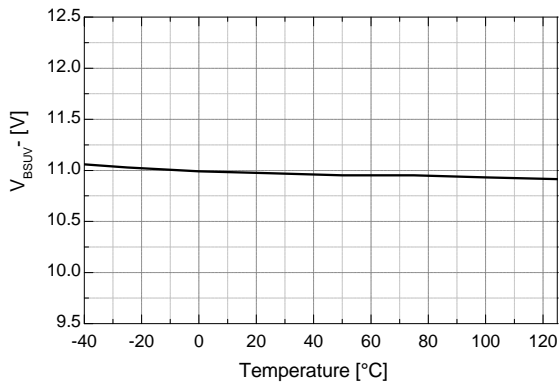

Figure 9. $V_{BS} UVLO (-)$ vs. Temperature

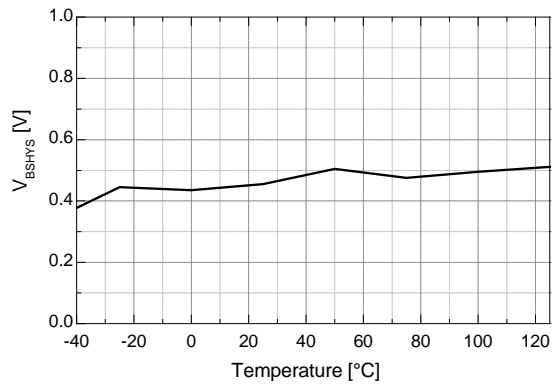

Figure 10. $V_{BS} UVLO$ Hysteresis vs. Temperature

Typical Characteristics (Continued)

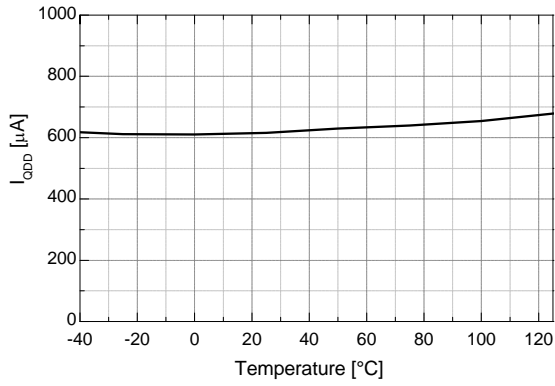

Figure 11. V_{DD} Quiescent Current vs. Temperature

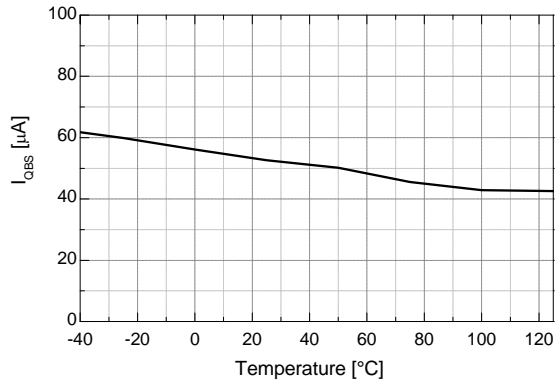

Figure 12. V_{BS} Quiescent Current vs. Temperature

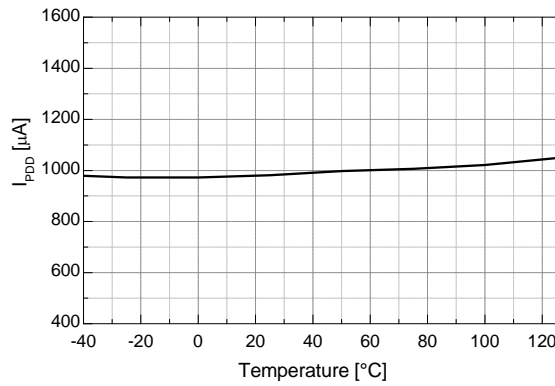

Figure 13. V_{DD} Operating Current vs. Temperature

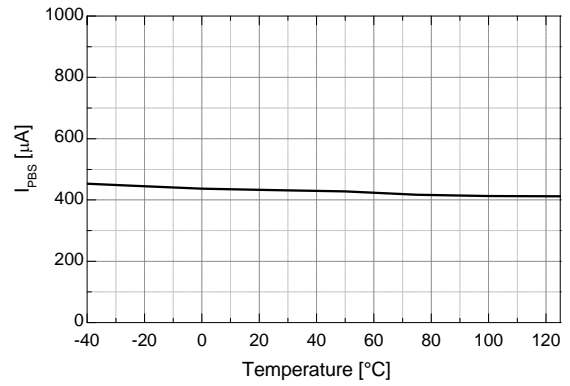

Figure 14. V_{BS} Operating Current vs. Temperature

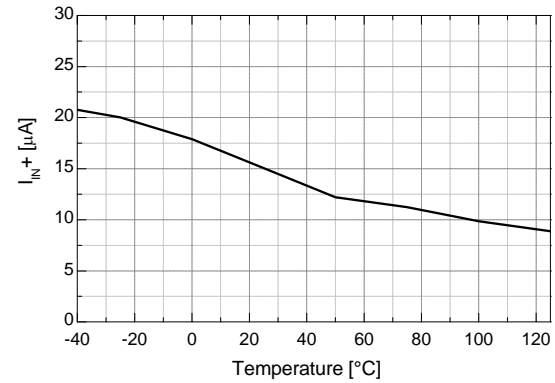

Figure 15. Logic Input Current vs. Temperature

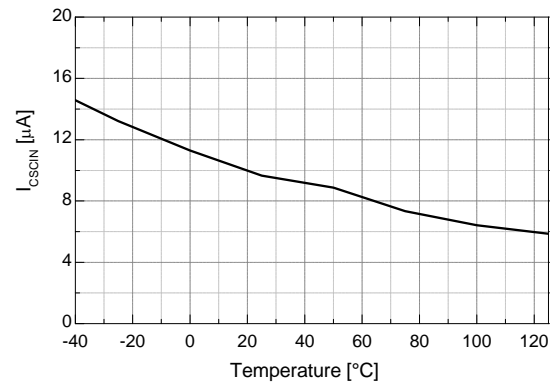

Figure 16. I_{CSCIN} vs. Temperature

Typical Characteristics (Continued)

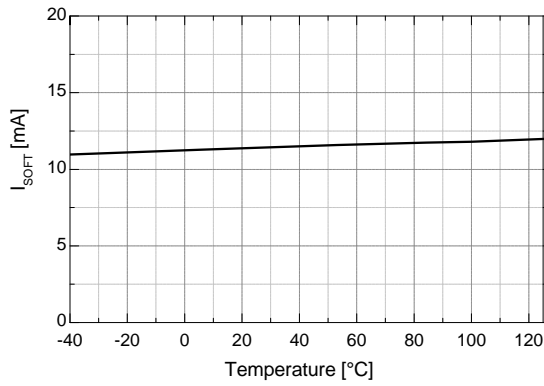

Figure 17. I_{SOFT} vs. Temperature

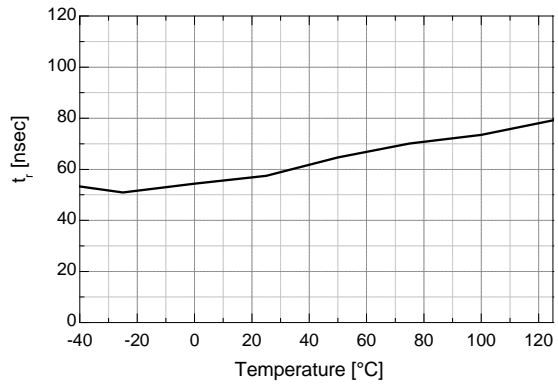

Figure 18. Turn-on Rising Time vs. Temperature

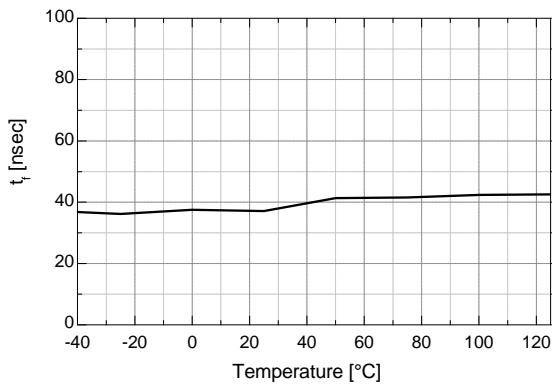

Figure 19. Turn-off Falling Time vs. Temperature

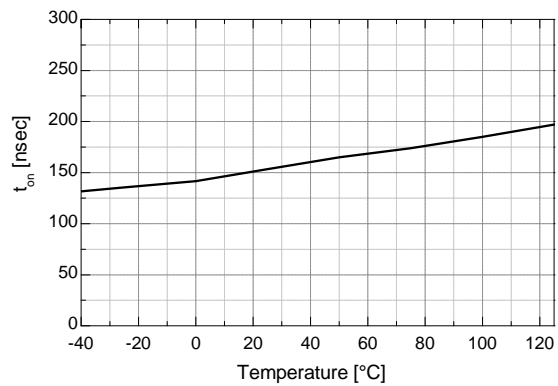

Figure 20. Turn-on Delay Time vs. Temperature

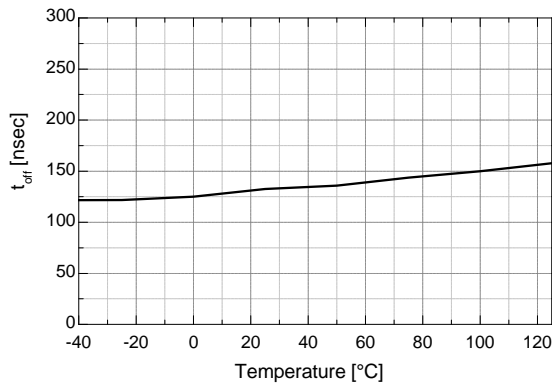

Figure 21. Turn-off Delay Time vs. Temperature

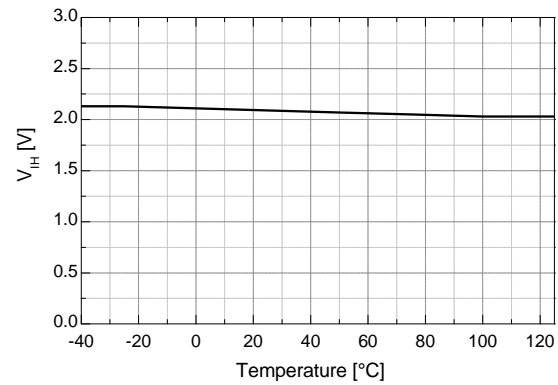

Figure 22. Logic Input High Voltage vs. Temperature

Typical Characteristics (Continued)

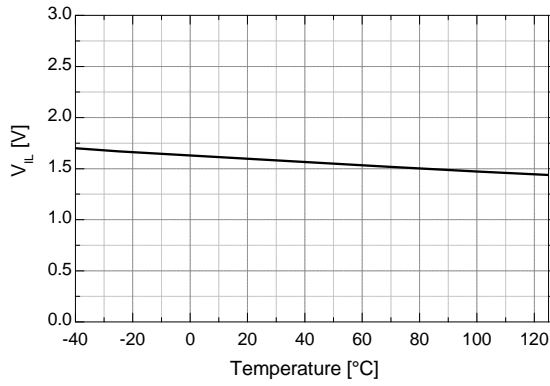

Figure 23. Logic Input Low Voltage vs. Temperature

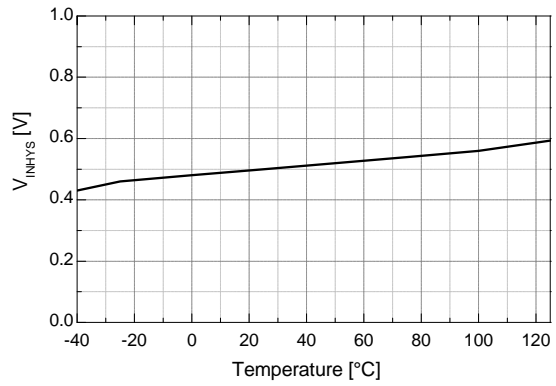

Figure 24. Logic Input Hysteresis vs. Temperature

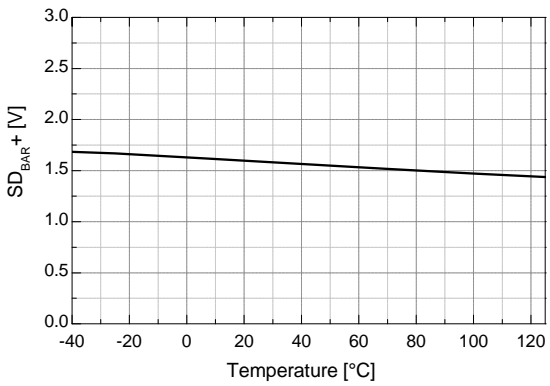

Figure 25. $\overline{\text{SD}}$ Positive Threshold vs. Temperature

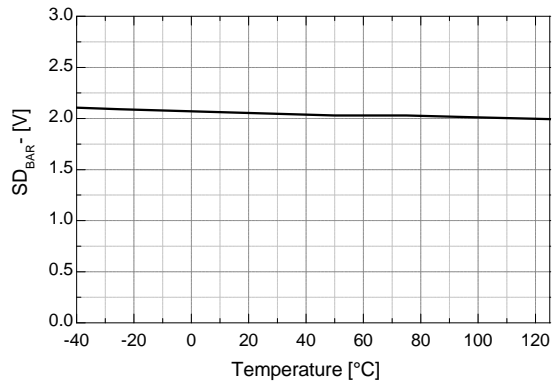

Figure 26. $\overline{\text{SD}}$ Negative Threshold vs. Temperature

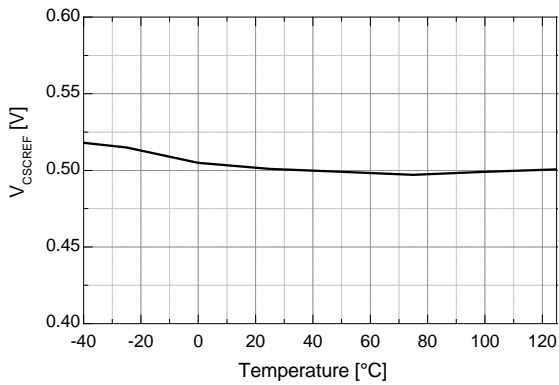

Figure 27. V_{CSCREF} vs. Temperature

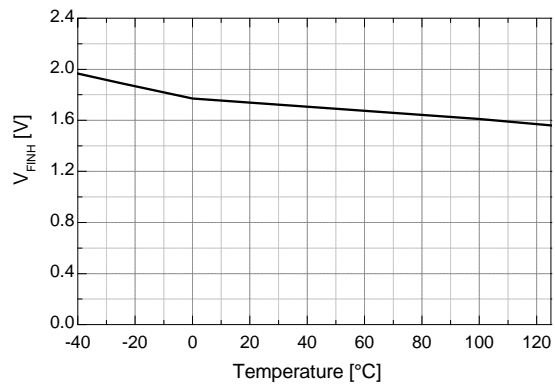

Figure 28. Fault Input High Voltage vs. Temperature

Typical Characteristics (Continued)

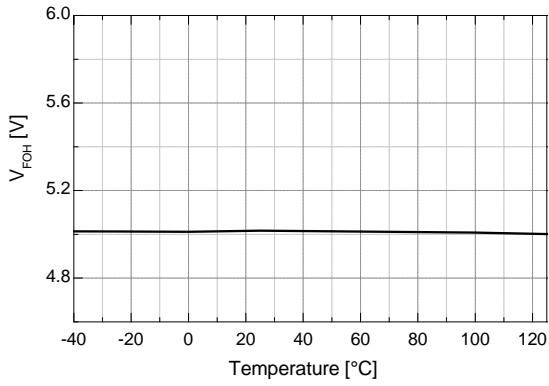

Figure 29. Fault Output High Voltage vs. Temperature

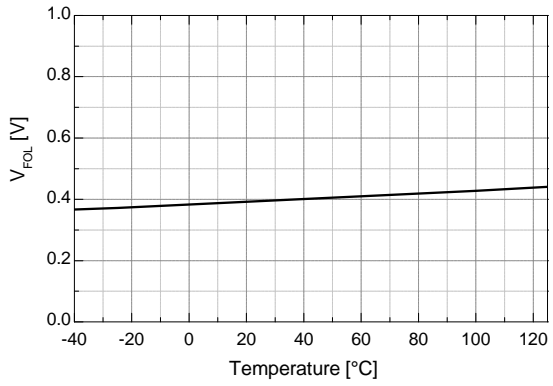

Figure 30. Fault Output Low Voltage vs. Temperature

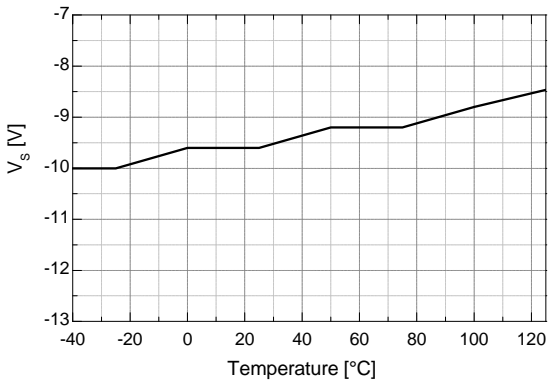

Figure 31. Allowable Negative V_S Voltage for Signal Propagation to High Side vs. Temperature

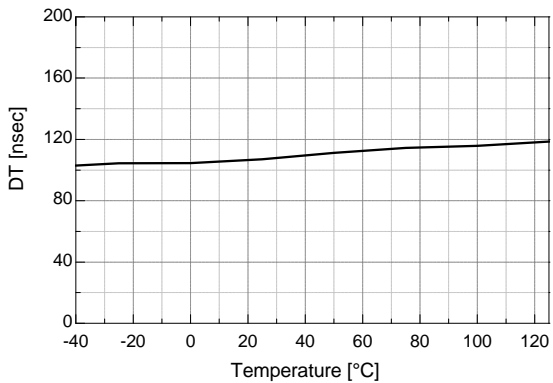
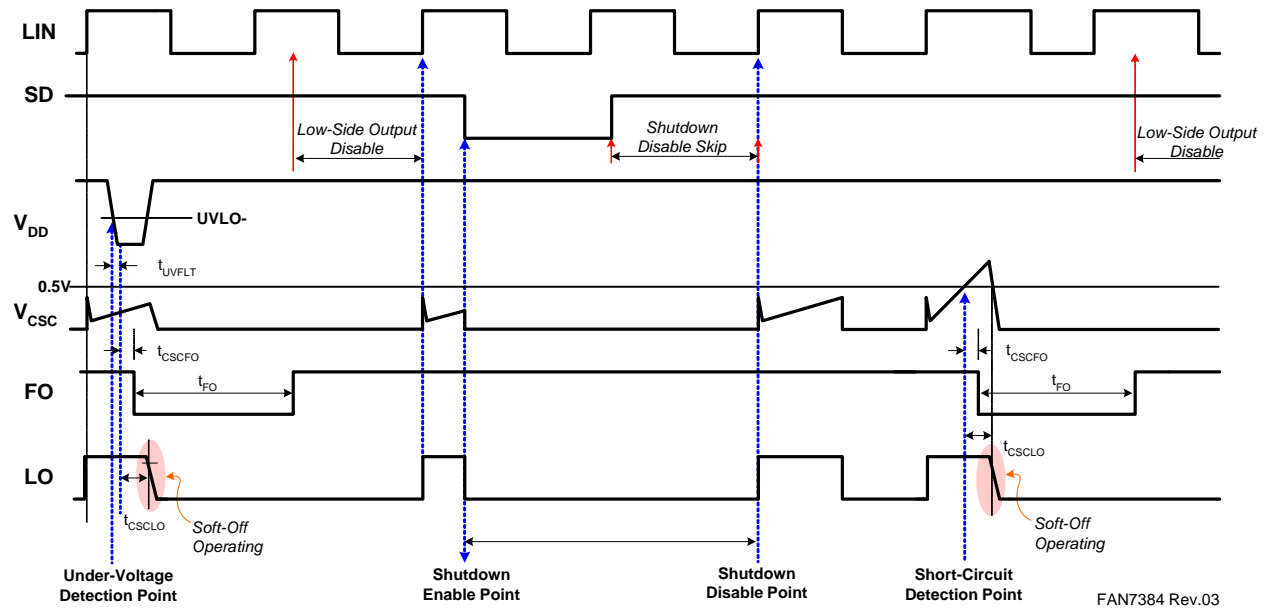

Figure 32. Dead Time vs. Temperature

Switching Time Definitions

The overall switching timing waveforms definition of FAN7384 as shown Figure 33.



FAN7384 Rev.03

Figure 33. Switching Timing Waveforms Definition

Typical Application Information

1. Protection Function

1.1 Under-Voltage Lockout (UVLO)

The high- and low-side drivers include under-voltage lockout (UVLO) protection circuitry that monitors the supply voltage (V_{DD}) and bootstrap capacitor voltage (V_{BS}) independently. It can be designed to prevent malfunction when V_{DD} and V_{BS} are lower than the specified threshold voltage. Moreover, the UVLO hysteresis prevents chattering during power supply transitions. If the supply voltage (V_{DD}) maintains an under-voltage condition over under-voltage filtering times (typically $16\mu\text{s}$), the fault and soft-off circuits are activated, as shown Figure 34.

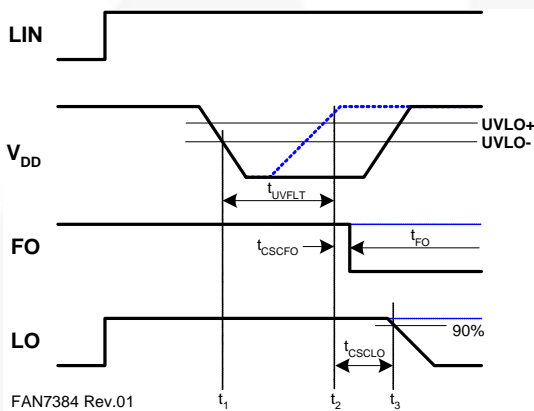

Figure 34. Waveforms for Under-Voltage Lockout

1.2 Shoot-Through Prevention Function

The FAN7384 has a shoot-through prevention circuitry that monitors the high- and low-side inputs. It can be designed to prevent outputs of high- and low-side turning on at same time, as shown Figure 35 and 36.

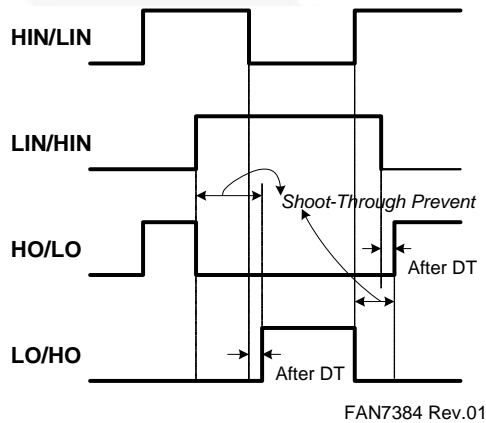

Figure 35. Waveforms for Shoot-Through Prevention

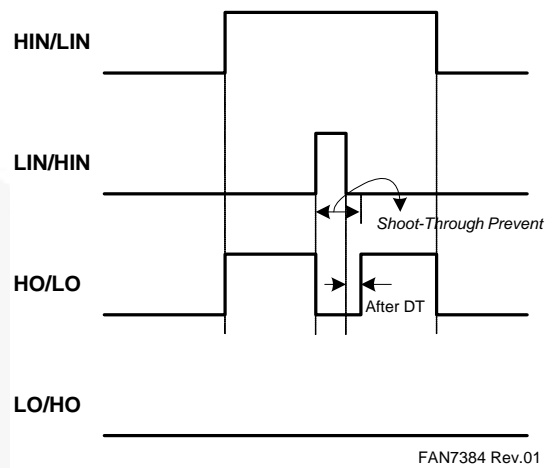

Figure 36. Waveforms for Shoot-Through Prevention

1.3 Over-Current Protection Function

The FAN7384 has over-current detection circuitry that monitors the current-by-current sensing resistor connected from the low-side switch source (V_{SL}) to ground.

It is a built-in time-filler from the over-current event to prevent malfunction from a noise source, such as leading-edge pulse in inductive load application, as shown Figure 37.

The sensing current is calculated as follows:

$$I_{CS} = \frac{V_{CSCREF}}{R_{CS}} [A] \quad (1)$$

where,

V_{CSCREF} : Reference voltage of current sense comparator

R_{CS} : Current sensing resistor

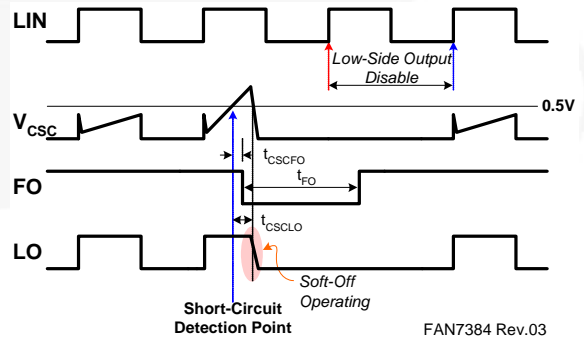

Figure 37. Waveforms for Short-Circuit Protection

2. Layout Considerations

For optimum performance, considerations must be taken during printed circuit board (PCB) layout.

2.1 Supply Capacitors

If the output stages are able to quickly turn on a switching device with a high value of current, the supply capacitors must be placed as close as possible to the device pins (V_{DD} and GND for the ground-tied supply, V_B and V_S for the floating supply) to minimize parasitic inductance and resistance.

2.2 Gate-Drive Loop

Current loops behave like antennae, able to receive and transmit noise. To reduce the noise coupling/emission and improve the power switch turn-on and off performance, gate-drive loops must be reduced as much as possible.

2.3 Ground Plane

To minimize noise coupling, the ground plane should not be placed under or near the high-voltage floating side.

Package Dimensions

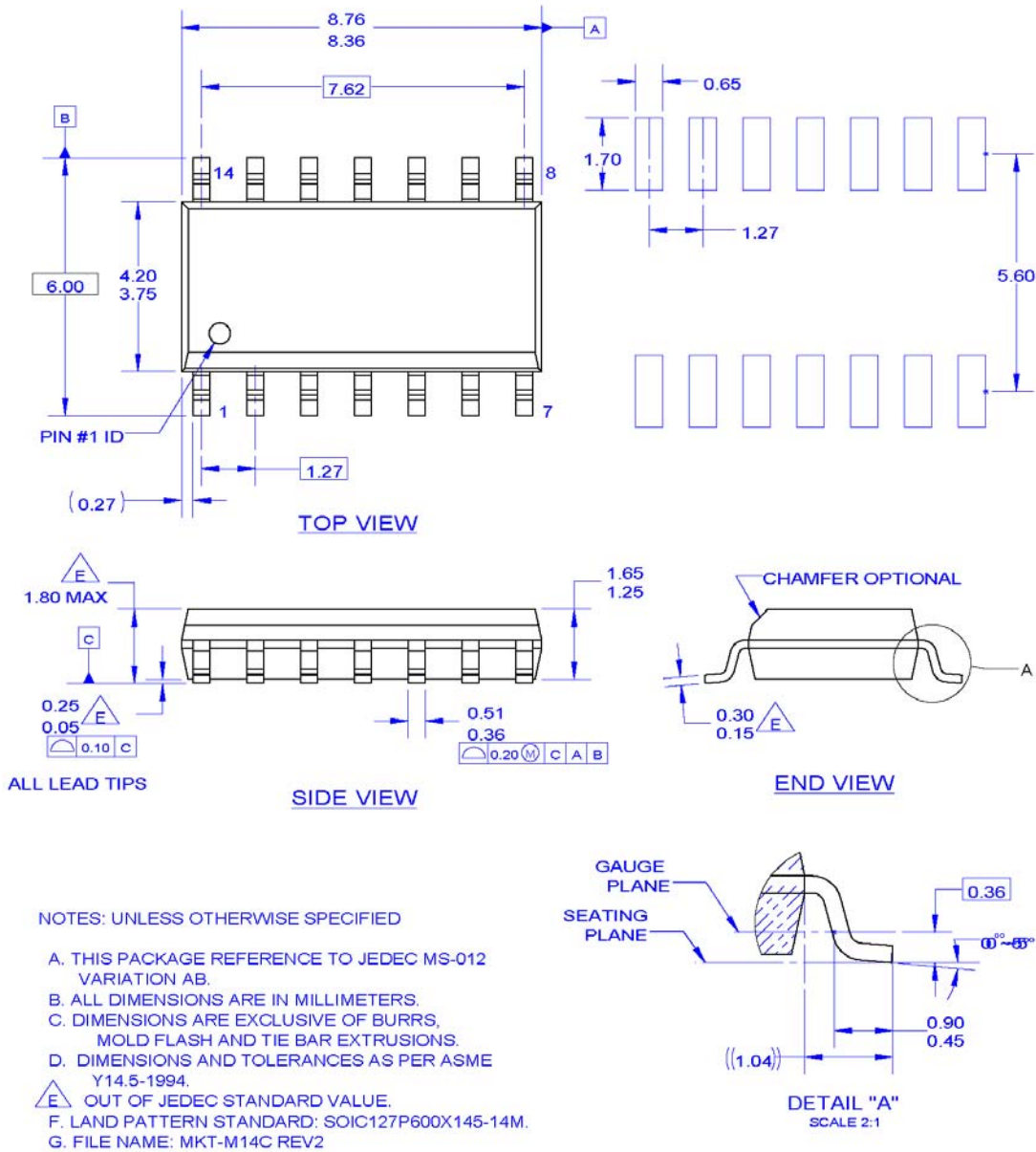

Figure 38. 14-Lead, Small Outline Integrated Circuit (SOIC), Non-JEDEC, .150 Inch Narrow Body, 225SOP

Package drawings are provided as a service to customers considering Fairchild components. Drawings may change in any manner without notice. Please note the revision and/or date on the drawing and contact a Fairchild Semiconductor representative to verify or obtain the most recent revision. Package specifications do not expand the terms of Fairchild's worldwide terms and conditions, specifically the warranty therein, which covers Fairchild products.

Always visit Fairchild Semiconductor's online packaging area for the most recent package drawings:

<http://www.fairchildsemi.com/packaging/>



TRADEMARKS

The following includes registered and unregistered trademarks and service marks, owned by Fairchild Semiconductor and/or its global subsidiaries, and is not intended to be an exhaustive list of all such trademarks.

- | | | | |
|---|--|---|---|
| 2Cool™ | F-PFST™ | PowerTrench® | The Power Franchise® |
| AccuPower™ | FRFET® | PowerXS™ | the power franchise |
| AX-CAP™* | Global Power Resource™ | Programmable Active Droop™ | TinyBoost™ |
| BitSiC™ | GreenBridge™ | QFET® | TinyBuck™ |
| Build it Now™ | Green FPS™ | QS™ | TinyCalc™ |
| CorePLUS™ | Green FPS™ e-Series™ | Quiet Series™ | TinyLogic® |
| CorePOWER™ | Gmax™ | RapidConfigure™ | TINYOPTO™ |
| CROSS VOLT™ | GTO™ |  | TinyPower™ |
| CTL™ | IntelliMAX™ | Saving our world, 1mW/W/kW at a time™ | TinyPWM™ |
| Current Transfer Logic™ | ISOPLANAR™ | SignalWise™ | TinyWire™ |
| DEUXPEED® | Making Small Speakers Sound Louder and Better™ | SmartMax™ | TranSiC™ |
| Dual Cool™ | MegaBuck™ | SMART START™ | TriFault Detect™ |
| EcoSPARK® | MICROCOUPLER™ | Solutions for Your Success™ | TRUECURRENT®* |
| EfficientMax™ | MicroFET™ | SPM® | µSerDes™ |
| ESBC™ | MicroPak™ | STEALTH™ |  |
|  | MicroPak2™ | SuperFET® | UHC® |
| Fairchild® | MillerDrive™ | SuperSOT™-3 | Ultra FRFET™ |
| Fairchild Semiconductor® | MotionMax™ | SuperSOT™-6 | UniFET™ |
| FACT Quiet Series™ | mWSaver™ | SuperSOT™-8 | VCS™ |
| FACT® | OptoHi™ | SupreMOS® | VisualMax™ |
| FAST® | OPTOLOGIC® | SyncFET™ | VoltagePlus™ |
| FastvCore™ | OPTOPLANAR® | Sync-Lock™ | XS™ |
| FETBench™ | |  | |
| FlashWriter®* | | | |
| FPS™ | | | |

* Trademarks of System General Corporation, used under license by Fairchild Semiconductor.

DISCLAIMER

FAIRCHILD SEMICONDUCTOR RESERVES THE RIGHT TO MAKE CHANGES WITHOUT FURTHER NOTICE TO ANY PRODUCTS HEREIN TO IMPROVE RELIABILITY, FUNCTION, OR DESIGN. FAIRCHILD DOES NOT ASSUME ANY LIABILITY ARISING OUT OF THE APPLICATION OR USE OF ANY PRODUCT OR CIRCUIT DESCRIBED HEREIN; NEITHER DOES IT CONVEY ANY LICENSE UNDER ITS PATENT RIGHTS, NOR THE RIGHTS OF OTHERS. THESE SPECIFICATIONS DO NOT EXPAND THE TERMS OF FAIRCHILD'S WORLDWIDE TERMS AND CONDITIONS, SPECIFICALLY THE WARRANTY THEREIN, WHICH COVERS THESE PRODUCTS.

LIFE SUPPORT POLICY

FAIRCHILD'S PRODUCTS ARE NOT AUTHORIZED FOR USE AS CRITICAL COMPONENTS IN LIFE SUPPORT DEVICES OR SYSTEMS WITHOUT THE EXPRESS WRITTEN APPROVAL OF FAIRCHILD SEMICONDUCTOR CORPORATION.

As used herein:

1. Life support devices or systems are devices or systems which, (a) are intended for surgical implant into the body or (b) support or sustain life, and (c) whose failure to perform when properly used in accordance with instructions for use provided in the labeling, can be reasonably expected to result in a significant injury of the user.
2. A critical component in any component of a life support, device, or system whose failure to perform can be reasonably expected to cause the failure of the life support device or system, or to affect its safety or effectiveness.

ANTI-COUNTERFEITING POLICY

Fairchild Semiconductor Corporation's Anti-Counterfeiting Policy. Fairchild's Anti-Counterfeiting Policy is also stated on our external website, www.fairchildsemi.com, under Sales Support.

Counterfeiting of semiconductor parts is a growing problem in the industry. All manufacturers of semiconductor products are experiencing counterfeiting of their parts. Customers who inadvertently purchase counterfeit parts experience many problems such as loss of brand reputation, substandard performance, failed applications, and increased cost of production and manufacturing delays. Fairchild is taking strong measures to protect ourselves and our customers from the proliferation of counterfeit parts. Fairchild strongly encourages customers to purchase Fairchild parts either directly from Fairchild or from Authorized Fairchild Distributors who are listed by country on our web page cited above. Products customers buy either from Fairchild directly or from Authorized Fairchild Distributors are genuine parts, have full traceability, meet Fairchild's quality standards for handling and storage and provide access to Fairchild's full range of up-to-date technical and product information. Fairchild and our Authorized Distributors will stand behind all warranties and will appropriately address any warranty issues that may arise. Fairchild will not provide any warranty coverage or other assistance for parts bought from Unauthorized Sources. Fairchild is committed to combat this global problem and encourage our customers to do their part in stopping this practice by buying direct or from authorized distributors.

PRODUCT STATUS DEFINITIONS

Definition of Terms

Datasheet Identification	Product Status	Definition
Advance Information	Formative / In Design	Datasheet contains the design specifications for product development. Specifications may change in any manner without notice.
Preliminary	First Production	Datasheet contains preliminary data; supplementary data will be published at a later date. Fairchild Semiconductor reserves the right to make changes at any time without notice to improve design.
No Identification Needed	Full Production	Datasheet contains final specifications. Fairchild Semiconductor reserves the right to make changes at any time without notice to improve the design.
Obsolete	Not In Production	Datasheet contains specifications on a product that is discontinued by Fairchild Semiconductor. The datasheet is for reference information only.

Rev. I62

ON Semiconductor and  are trademarks of Semiconductor Components Industries, LLC dba ON Semiconductor or its subsidiaries in the United States and/or other countries. ON Semiconductor owns the rights to a number of patents, trademarks, copyrights, trade secrets, and other intellectual property. A listing of ON Semiconductor's product/patent coverage may be accessed at www.onsemi.com/site/pdf/Patent-Marking.pdf. ON Semiconductor reserves the right to make changes without further notice to any products herein. ON Semiconductor makes no warranty, representation or guarantee regarding the suitability of its products for any particular purpose, nor does ON Semiconductor assume any liability arising out of the application or use of any product or circuit, and specifically disclaims any and all liability, including without limitation special, consequential or incidental damages. Buyer is responsible for its products and applications using ON Semiconductor products, including compliance with all laws, regulations and safety requirements or standards, regardless of any support or applications information provided by ON Semiconductor. "Typical" parameters which may be provided in ON Semiconductor data sheets and/or specifications can and do vary in different applications and actual performance may vary over time. All operating parameters, including "Typicals" must be validated for each customer application by customer's technical experts. ON Semiconductor does not convey any license under its patent rights nor the rights of others. ON Semiconductor products are not designed, intended, or authorized for use as a critical component in life support systems or any FDA Class 3 medical devices or medical devices with a same or similar classification in a foreign jurisdiction or any devices intended for implantation in the human body. Should Buyer purchase or use ON Semiconductor products for any such unintended or unauthorized application, Buyer shall indemnify and hold ON Semiconductor and its officers, employees, subsidiaries, affiliates, and distributors harmless against all claims, costs, damages, and expenses, and reasonable attorney fees arising out of, directly or indirectly, any claim of personal injury or death associated with such unintended or unauthorized use, even if such claim alleges that ON Semiconductor was negligent regarding the design or manufacture of the part. ON Semiconductor is an Equal Opportunity/Affirmative Action Employer. This literature is subject to all applicable copyright laws and is not for resale in any manner.

PUBLICATION ORDERING INFORMATION

LITERATURE FULFILLMENT:



Literature Distribution Center for ON Semiconductor
19521 E. 32nd Pkwy, Aurora, Colorado 80011 USA
Phone: 303-675-2175 or 800-344-3860 Toll Free USA/Canada
Fax: 303-675-2176 or 800-344-3867 Toll Free USA/Canada
Email: orderlit@onsemi.com

N. American Technical Support: 800-282-9855 Toll Free
USA/Canada
Europe, Middle East and Africa Technical Support:
Phone: 421 33 790 2910
Japan Customer Focus Center
Phone: 81-3-5817-1050

ON Semiconductor Website: www.onsemi.com
Order Literature: <http://www.onsemi.com/orderlit>
For additional information, please contact your local
Sales Representative

Looking for pricing, stock, or lifecycle information?

Click below to explore more details on WIN SOURCE:

-  [View FAN7384MX on WIN SOURCE](#)
-  [Fairchild/ON Semiconductor Information](#)

Optimize Your Supply Chain with WIN SOURCE Solutions

-  Global Sourcing Solution
-  Obsolete Management
-  Cost Control Management
-  Shortage Management
-  Alternative Solution
-  Excess Inventory Management