

FAN5610

LED Driver for White, Blue, or Any Color LED

Features

- LED Driver for Four Parallel-connected LEDs
- Low Voltage Drop (<350mV) to Support Direct Li-ion Applications with Low VF LEDs
- Independent Control Loop for each LED
- Regulated, Matched Constant Current in LEDs
- No External Components
- No EMI, No Switching Noise
- Built-in DAC for Digital and PWM Brightness Control
- Up to 91% Maximum Efficiency
- Up to 84mA (21mA/LED) Bias Current
- 2.7V to 5.5V Input Voltage Range
- ICC < 1µA in Shutdown Mode
- 3mm x 3mm MLP-8 Package

Applications

- Cell Phones
- Handheld Computers
- PDA, DSC, MP3 Players
- LCD Display Modules
- Keyboard Backlight
- LED Displays

Description

The FAN5610 generates matched current source drives for a maximum of four LEDs. Since each LED current source has its own self-regulating loop, precise current matching is maintained even if there is a substantial forward voltage spread among the LEDs. LED pre-selection therefore is not required. To minimize voltage drop and maximize efficiency, the value of the internal current sense resistors connected in series with the LEDs is very low (10Ω). This is an important consideration for direct DC-driven white LEDs in battery-powered systems.

The LED current can be set to 0mA (OFF Mode), 7mA, 14mA, and 21mA with a built-in, two-bit, digital-to-analog converter. Customized current settings can also be used. When the control bits are set to zero, the internal circuitry is disabled and the quiescent current drops below 1µA.

Both digital input lines (A, B) can be pulse-width-modulated (PWM). Using PWM, any value of average LED current can be obtained within the 1 to 20 mA range. The FAN5610 is available in an 8-lead 3x3mm MLP package.

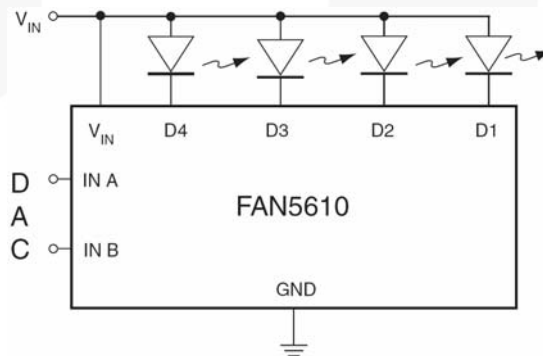

Typical Application

Ordering Information

Part Number	Operating Temperature Range	Package	Packing Method
FAN5610MPX	-40 to +85°C	3x3mm, 8-Lead, Molded Leadless Package (MLP)	Tape and Reel

All packages are lead free per JEDEC: J-STD-020B standard.

Pin Configuration

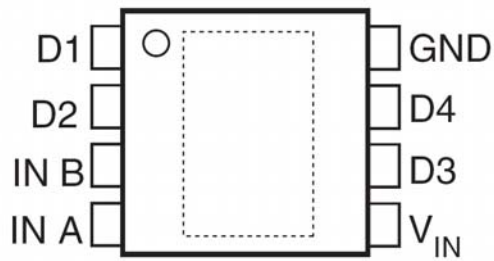

Figure 1. Pin Configuration

Pin Definitions

Pin Name	Description
D1	Cathode of Diode No.1
D2	Cathode of Diode No. 2
IN B	DAC Input B, Active High
IN A	DAC Input A, Active High
V _{IN}	Input Voltage
D3	Cathode of Diode No. 3
D4	Cathode of Diode No. 4
GND	Ground

Absolute Maximum Ratings

Stresses exceeding the absolute maximum ratings may damage the device. The device may not function or be operable above the recommended operating conditions and stressing the parts to these levels is not recommended. In addition, extended exposure to stresses above the recommended operating conditions may affect device reliability. The absolute maximum ratings are stress ratings only.

Symbol	Parameter	Min.	Max.	Unit
V_{IN}	IN A / IN B Voltage to GND	-0.3	6.0	V
T_L	Lead Soldering Temperature, 10 Seconds		+300	°C
T_{JA}	Operating Junction Temperature Range		+150	°C
T_{STG}	Storage Temperature	-55	+150	°C
ESD	Human Body Model, JESD22-A114	4		kV
	Charged Device Model, JESD22-C101	2		

Recommended Operating Conditions

The Recommended Operating Conditions table defines the conditions for actual device operation. Recommended operating conditions are specified to ensure optimal performance to the datasheet specifications. Fairchild does not recommend exceeding them or designing to Absolute Maximum Ratings.

Symbol	Parameter	Min.	Typ.	Max.	Unit
$V_{IN}^{(1)}$	Input Voltage Range	2.7		5.5	V
T_A	Operating Ambient Temperature Range	-40	+25	+85	°C

Note:

- The minimum operating voltage depends on the LED operating voltage, as described in the *Application Information* section.

DC Electrical Characteristics

$V_{IN} = 3.3V$ to $5.5V$, $T_A = 25^\circ C$, unless otherwise noted. **Boldface** values indicate specifications over the ambient operating temperature range.

Symbol	Parameter	Conditions	Min.	Typ.	Max.	Units
I_{IN}	Supply Current, OFF Mode	IN A = 0, IN B = 0		<1	2	μA
I_{OUT}	Output Current Accuracy	$V_D > 0.3V$, IN A = 1, IN B = 1	14.8	21.0	26.0	mA
I_{MATCH}	LED to LED Current Matching	$V_{IN} = 3.6V$, IN A = 1, IN B = 1	-7.5		7.5	%
V_{IN_DAC}	DAC Input Voltage Threshold	LOW	0		$0.3 \times V_{IN}$	V
		HIGH	$0.6 \times V_{IN}$		V_{IN}	
	Peak Efficiency	LED $V_F = 3V$ at 20mA		91		%

Block Diagram

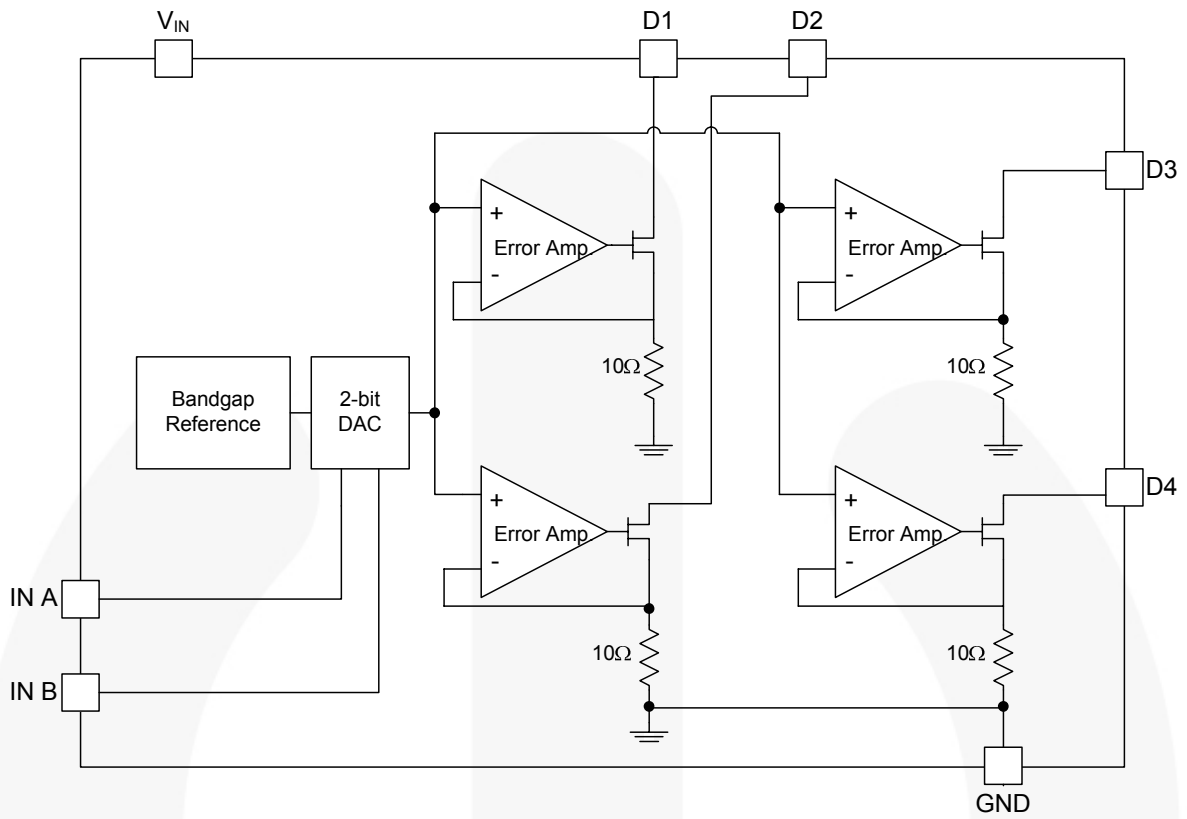

Figure 2. Block Diagram

Typical Performance Characteristics

Unless otherwise specified, $T_A = 25^\circ\text{C}$ and using Fairchild QTLP670IW Super Bright LED.

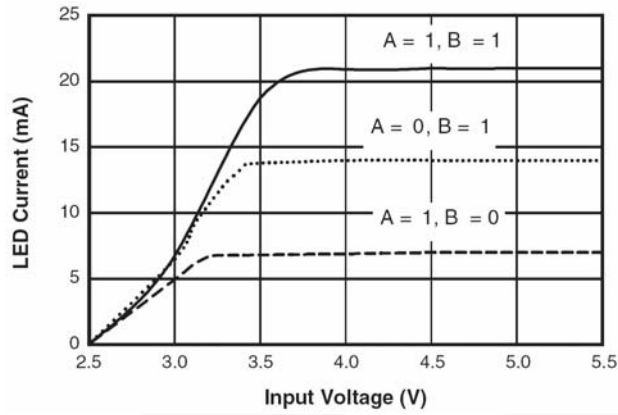

Figure 3. LED Current vs. Input Voltage (Low V_F - White LED)

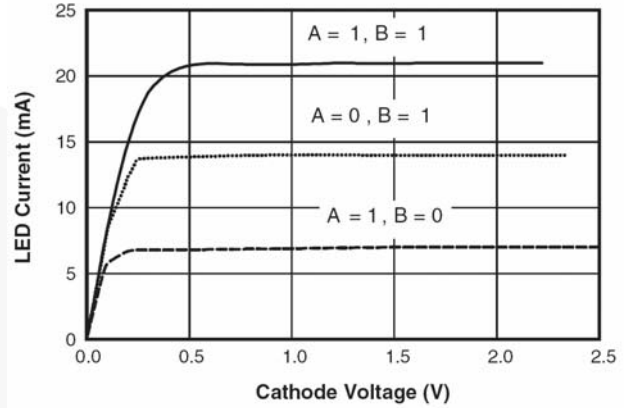

Figure 4. LED Current vs. Cathode Voltage

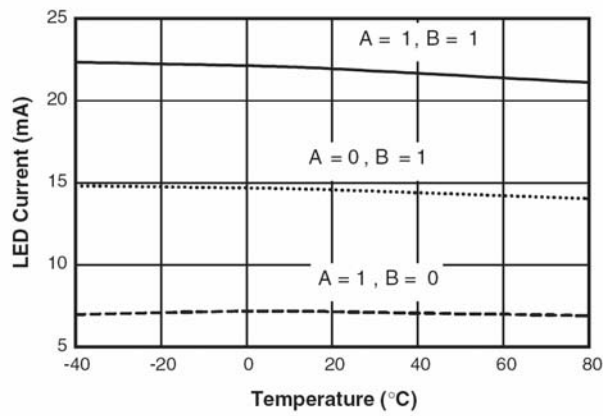

Figure 5. LED Current vs. Temperature

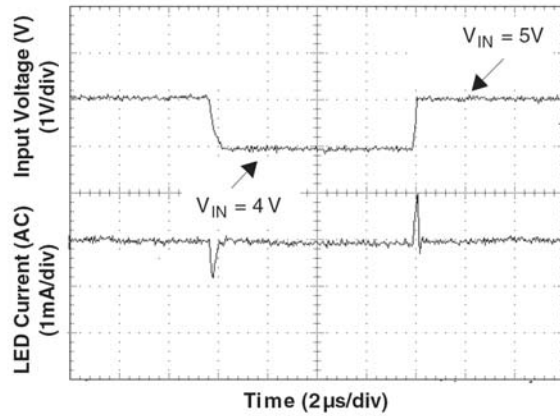

Figure 6. Line Transient Response

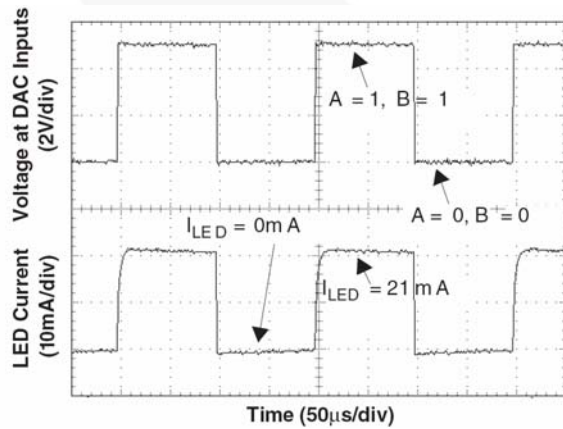

Figure 7. DAC Transient Response

Functional Description

Digital LED Brightness Control

Digital Control

A digital-to-analog converter selects the following modes of operation: OFF, 7mA, 14mA, and 21mA, per diode. In addition, by turning the "IN B" pin ON and OFF, the current can be modulated between 8 to 20mA to achieve any $I_{AVERAGE}$ value.

Digital Control with PWM

Any pin can be modulated by a variable duty cycle (δ) pulse train. Care should be taken not to use too low a frequency, otherwise a flickering effect can be seen. The minimum range is between 100Hz to 5kHz. For the maximum range of LED current, A and B can be modulated at the same time.

Table 1. Digital Control Brightness Modes

A	0	1	0	1
B	0	0	1	1
I_{LED}	OFF	7mA	14mA	21mA

Digital Control with PWM

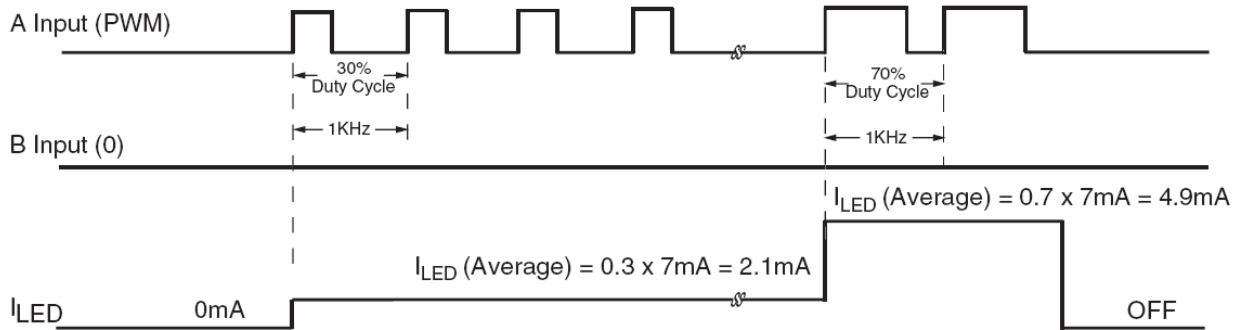

Figure 8. A is PWM and B is LOW. $I_{LED} (average) = \delta \times 7mA$, where δ is duty cycle.⁽²⁾

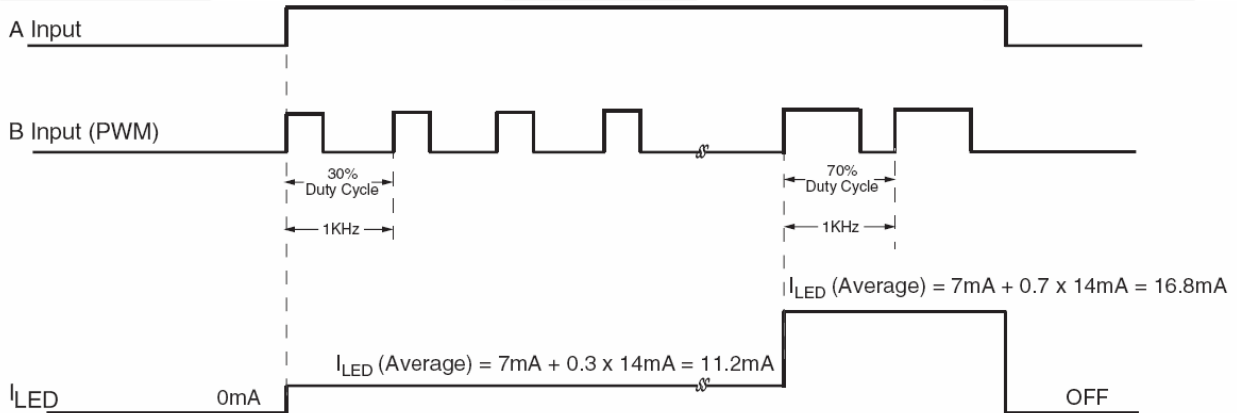

Figure 9. A is HIGH and B is PWM. $I_{LED} (average) = 7mA + \delta \times 14mA$, where δ is duty cycle.^(3,4)

Notes:

- Proportionally select the duty cycle to achieve a typical LED current between 1mA to 6mA.
- If either input A or B is HIGH continuously, the other input can be modulated at a maximum rate of 30kHz. If this is not the case, the maximum rate of modulation should be limited to 1kHz.
- Proportionally select the duty cycle to achieve a typical LED current between 8mA to 20mA.

Digital Control with PWM (Continued)

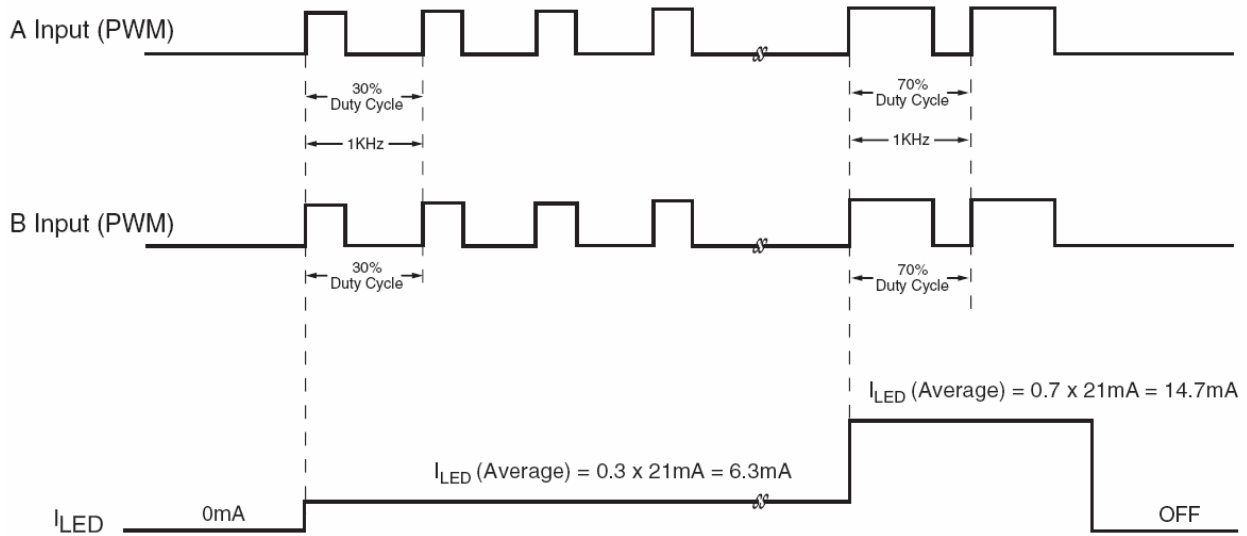

Figure 10. A and B are PWM. $I_{LED}(\text{average}) = \delta \times 21\text{mA}$, where δ is duty cycle.⁽⁵⁾

Note:

5. Proportionally select the duty cycle to achieve a typical LED current between 1mA to 20mA.

Application Information

As seen in the block diagram in Figure 2, the FAN5610 includes four independent current regulators able to maintain a programmable constant current through LEDs, regardless of their forward voltage. This is true over a wide range of input voltages, starting from $V_{F_max} + 0.35\text{V}$, where V_{F_max} is the highest forward voltage among the LEDs driven by FAN5610. The independence of current (LED current changes less than 1%) with change in V_{IN} and V_F for $V_{IN} > V_{F_max} + 0.35\text{V}$, is shown in Figure 11.

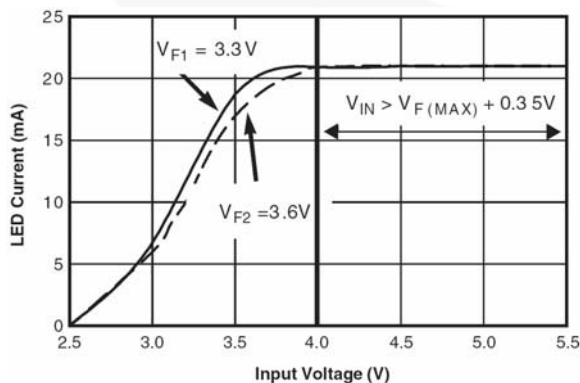

Figure 11. Current Regulation Performance

Program the LED's brightness by applying a continuous voltage level or a PWM signal at the inputs of the built-in digital to analog converter (DAC). When a PWM signal is utilized to drive the DAC inputs, the current through the LEDs is switched between two levels with the PWM signal frequency. Consequently, the average current changes with the duty cycle. The LED current waveform tracks the PWM signal, so the LEDs brightness depends on the duty cycle.

For white LEDs, the spectral composition is optimal at a current level specified by the manufacturer. The DAC inputs should be programmed to set the current required to achieve white LED spectrum and PWM used for dimming. To maintain the "purest" white, the current through the LEDs should be switched between zero and a specified current level (usually around 20mA) corresponding to the white light chromaticity coordinate.

Conversion errors are minimized, and the best LED-to-LED matching is achieved over the entire range of average current settings, when PWM brightness control is used to modulate the LED current between zero and the maximum value ($A=1, B=1$).

Application Examples

Example 1: Drive low V_F white or blue LEDs directly from single-cell Li-ion

When using white or blue low- V_F LEDs, and utilizing the driver's low voltage drop, only 3.45V in V_{IN} is needed for the full 20mA LED current. Usually at 3.1V, there is still 5mA current available for the LEDs. The single-cell Li-ion is utilized in most applications, like cell phones or digital still cameras. In most cases, the Li-ion battery voltage level only goes down to 3.0V voltage level, not down to the full discharge level (2.7V), before requesting the charger.

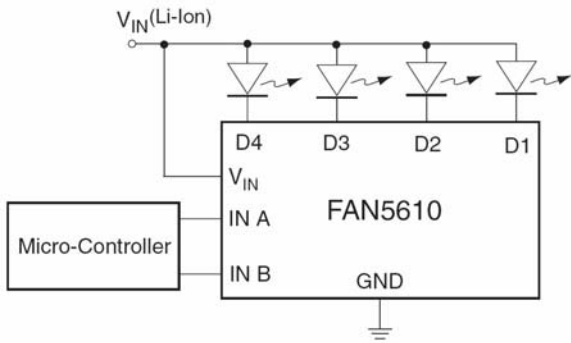

Figure 12. Drive Low V_F White or Blue LEDs Directly from Single-cell Li-ion

- $V_{DROD} \sim 0.35V$ (1)
- V_F (at 20mA) < 3.1V (Low V_F) (2)
- V_{IN} (at 20mA) = $V_{DROD} + V_F = 3.45V$ (3)
- V_{IN} (at 5mA typical) $\sim 3.1V$ (4)

where V_{IN} = single-cell Li-ion voltage.

Key Advantages:

- No boost circuit needed for the LCD or keyboard backlight
- Driver directly connected to a Li-ion battery
- No EMI, no switching noise, no boost efficiency lost, no capacitor, no inductor

Example 2: Drive high V_F white or blue LEDs from existing bus from 4.0V to 5.5V

High- V_F white or blue LEDs have forward-voltage drop in the range of 3.3V to 4.0V. Driving these LEDs with the maximum current of 20mA for maximum brightness usually requires a boost circuit for a single-cell Li-ion voltage range. In some cases, there is already a voltage bus in the system that can be utilized. Due to the low voltage drop, V_{IN} needs to be only 350mV higher than the voltage V_F of LEDs connected to FAN5610.

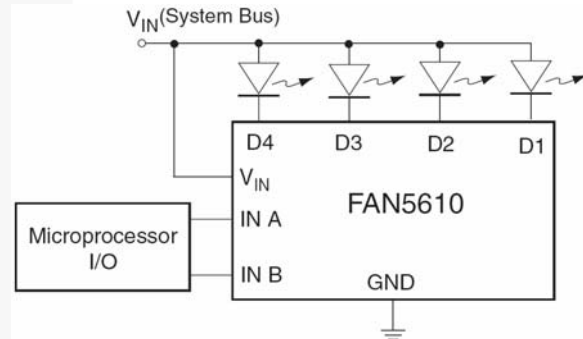

Figure 13. Drive High V_F White or Blue LEDs from Existing Bus from 4.0V to 5.5V

- $V_{DROD} \sim 0.35V$ (5)
 - V_F (at 20mA) = 3.3V to 4.0V (High V_F) (6)
 - V_{IN} (at 20mA) $\geq V_{DROD} + V_F = 4.35V$ (max.) (7)
- where V_{IN} = existing bus = 5V.

Key Advantages:

- No boost circuit needed for LCD or keyboard backlight
- Driver utilizes the existing bus
- Low voltage drop provides the full 20mA LED current at the lowest possible voltage level

Physical Dimensions

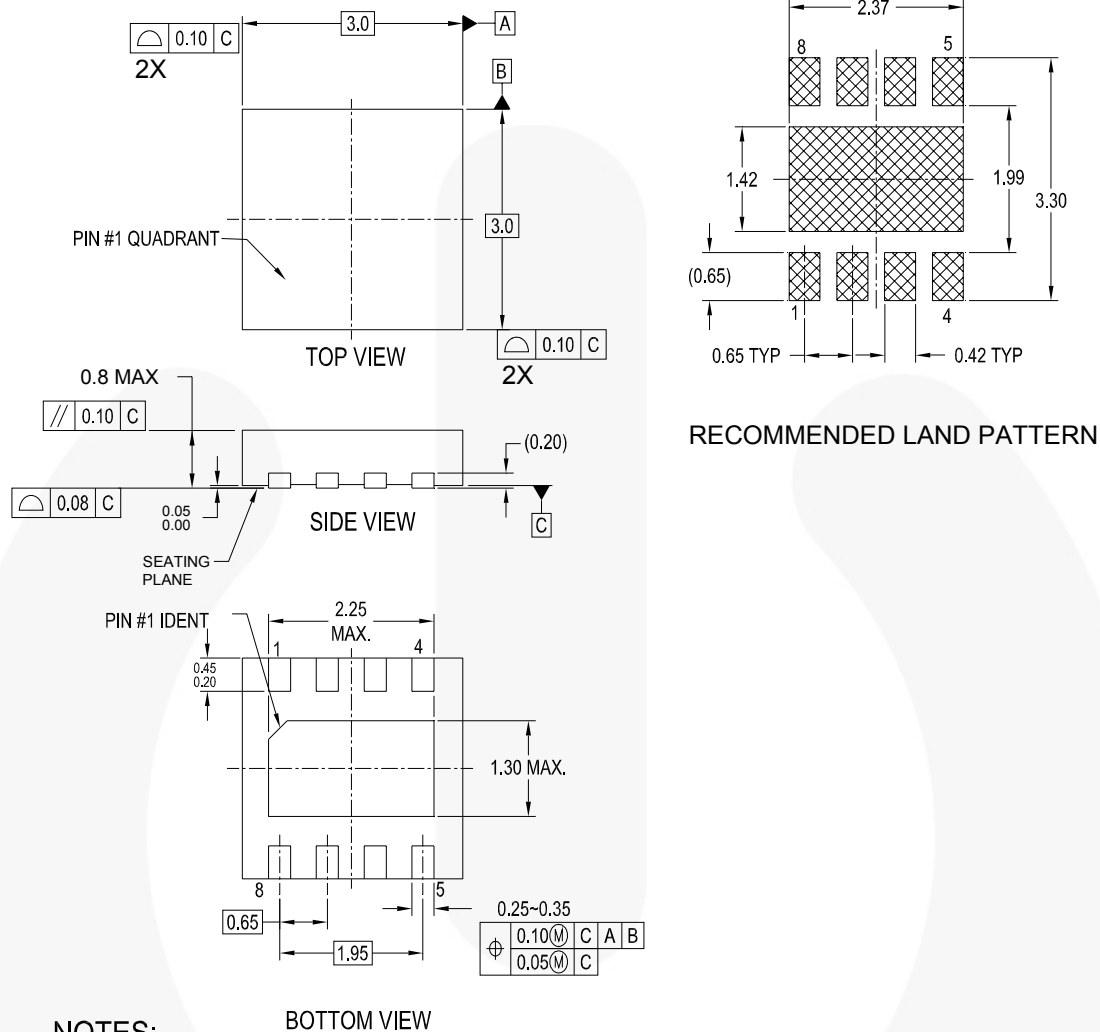

NOTES:

- A. CONFORMS TO JEDEC REGISTRATION MO-229, VARIATION VEEC, DATED 11/2001
- B. DIMENSIONS ARE IN MILLIMETERS.
- C. DIMENSIONS AND TOLERANCES PER ASME Y14.5M, 1994
- D. FILENAME: MKT-MLP08Drev2

Figure 14. 3x3mm, 8-Lead, Molded Leadless Package

Note:

- 6. Center pad, P1, may be left floating or be connected to GND (Pin 8). The center pad **must not** be used as an alternative GND connection to Pin 8.

Package drawings are provided as a service to customers considering Fairchild components. Drawings may change in any manner without notice. Please note the revision and/or date on the drawing and contact a Fairchild Semiconductor representative to verify or obtain the most recent revision. Package specifications do not expand the terms of Fairchild's worldwide terms and conditions, specifically the warranty therein, which covers Fairchild products.

Always visit Fairchild Semiconductor's online packaging area for the most recent package drawings:
<http://www.fairchildsemi.com/packaging/>



TRADEMARKS

The following includes registered and unregistered trademarks and service marks, owned by Fairchild Semiconductor and/or its global subsidiaries, and is not intended to be an exhaustive list of all such trademarks.

- | | | | |
|---|--|--|---|
| ACEX [®] | FPS [™] | PDP-SPM [™] | SupreMOS [™] |
| Build it Now [™] | FRFET [®] | Power220 [®] | SyncFET [™] |
| CorePLUS [™] | Global Power Resource SM | POWEREDGE [®] |  SYSTEM GENERAL |
| CROSSVOLT [™] | Green FPS [™] | Power-SPM [™] | The Power Franchise [®] |
| CTL [™] | Green FPS [™] e-Series [™] | PowerTrench [®] |  the Power franchise |
| Current Transfer Logic [™] | GTO [™] | Programmable Active Droop [™] | TinyBoost [™] |
| EcoSPARK [®] | i-Lo [™] | QFET [®] | TinyBuck [™] |
| EZSWITCH [™] * | IntelliMAX [™] | QS [™] | TinyLogic [®] |
|  E7 [™] | ISOPLANAR [™] | QT Optoelectronics [™] | TINYOPTO [™] |
|  F [®] | MegaBuck [™] | Quiet Series [™] | TinyPower [™] |
| Fairchild [®] | MICROCOUPLER [™] | RapidConfigure [™] | TinyPWM [™] |
| Fairchild Semiconductor [®] | MicroFET [™] | SMART START [™] | TinyWire [™] |
| FACT Quiet Series [™] | MicroPak [™] | SPM [®] | μSerDes [™] |
| FACT [®] | MillerDrive [™] | STEALTH [™] | UHC [®] |
| FAST [®] | Motion-SPM [™] | SuperFET [™] | Ultra FRFET [™] |
| FastvCore [™] | OPTOLOGIC [®] | SuperSOT [™] .3 | UniFET [™] |
| FlashWriter [®] * | OPTOPLANAR [®] | SuperSOT [™] .6 | VCX [™] |
| | | SuperSOT [™] .8 | |

* EZSWITCH[™] and FlashWriter[®] are trademarks of System General Corporation, used under license by Fairchild Semiconductor.

DISCLAIMER

FAIRCHILD SEMICONDUCTOR RESERVES THE RIGHT TO MAKE CHANGES WITHOUT FURTHER NOTICE TO ANY PRODUCTS HEREIN TO IMPROVE RELIABILITY, FUNCTION, OR DESIGN. FAIRCHILD DOES NOT ASSUME ANY LIABILITY ARISING OUT OF THE APPLICATION OR USE OF ANY PRODUCT OR CIRCUIT DESCRIBED HEREIN; NEITHER DOES IT CONVEY ANY LICENSE UNDER ITS PATENT RIGHTS, NOR THE RIGHTS OF OTHERS. THESE SPECIFICATIONS DO NOT EXPAND THE TERMS OF FAIRCHILD'S WORLDWIDE TERMS AND CONDITIONS, SPECIFICALLY THE WARRANTY THEREIN, WHICH COVERS THESE PRODUCTS.

LIFE SUPPORT POLICY

FAIRCHILD'S PRODUCTS ARE NOT AUTHORIZED FOR USE AS CRITICAL COMPONENTS IN LIFE SUPPORT DEVICES OR SYSTEMS WITHOUT THE EXPRESS WRITTEN APPROVAL OF FAIRCHILD SEMICONDUCTOR CORPORATION.

As used herein:

1. Life support devices or systems are devices or systems which, (a) are intended for surgical implant into the body or (b) support or sustain life, and (c) whose failure to perform when properly used in accordance with instructions for use provided in the labeling, can be reasonably expected to result in a significant injury of the user.
2. A critical component in any component of a life support, device, or system whose failure to perform can be reasonably expected to cause the failure of the life support device or system, or to affect its safety or effectiveness.

PRODUCT STATUS DEFINITIONS

Definition of Terms

Datasheet Identification	Product Status	Definition
Advance Information	Formative or In Design	This datasheet contains the design specifications for product development. Specifications may change in any manner without notice.
Preliminary	First Production	This datasheet contains preliminary data; supplementary data will be published at a later date. Fairchild Semiconductor reserves the right to make changes at any time without notice to improve design.
No Identification Needed	Full Production	This datasheet contains final specifications. Fairchild Semiconductor reserves the right to make changes at any time without notice to improve the design.
Obsolete	Not In Production	This datasheet contains specifications on a product that has been discontinued by Fairchild Semiconductor. The datasheet is printed for reference information only.

Rev. I33

Looking for pricing, stock, or lifecycle information?

Click below to explore more details on WIN SOURCE:

- ⊖ [View FAN5610MPX on WIN SOURCE](#)
- ⊖ [Fairchild/ON Semiconductor Information](#)

Optimize Your Supply Chain with WIN SOURCE Solutions

- ✓ Global Sourcing Solution
- ✓ Obsolete Management
- ✓ Cost Control Management
- ✓ Shortage Management
- ✓ Alternative Solution
- ✓ Excess Inventory Management