



**Features:**

- Motor: Brushless DC
- Motor Protection: Impedance Protected
- Bearing Type: Two Ball, Sleeve, or Hydro Dynamic
- Connection: UL 1007 AWG 24, 290mm Wire Leads
- Frame Material: Plastic UL94V-0
- Impeller Material: Plastic UL94V-0
- Operating Temp:
  - Two Ball: -10°C~70°C
  - Sleeve: -10°C~60°C
  - Hydro Dynamic: -10°C~70°C
- Life Expectancy:
  - Two Ball: 70,000 Hours
  - Sleeve: 30,000 Hours
  - Hydro Dynamic: 50,000 Hours



Fan-S Division



Model No.	Volt.	Current	Power	Rated Speed	Maximum AirFlow		Maximum Static Pressure		Noise Level	Weight
	(VDC)	(A)	(W)	(rpm)	(CMM)	(CFM)	(InAq)	(mmAq)	(dB/A)	(g)
FAD1-09225C * AW11	12	0.06	0.72	1600	0.858	30.303	0.034	0.887	19.1	92.0
FAD1-09225C * LW11	12	0.10	1.20	2100	1.152	40.689	0.081	2.062	29.2	92.0
FAD1-09225C * MW11	12	0.15	1.80	2400	1.263	44.655	0.101	2.565	31.2	92.0
FAD1-09225C * HW11	12	0.24	2.88	2900	1.587	56.069	0.146	3.721	37.5	92.0
FAD1-09225C * JW11	12	0.28	3.36	3300	1.753	61.929	0.187	4.760	42.2	92.0
FAD1-09225D * LW11	24	0.05	1.20	2100	1.152	40.689	0.081	2.062	29.2	92.0
FAD1-09225D * MW11	24	0.08	1.92	2400	1.263	44.655	0.101	2.565	31.2	92.0
FAD1-09225D * HW11	24	0.15	3.60	2900	1.587	56.069	0.146	3.721	37.5	92.0

\* Indicates "B" (Ball Bearing), "S" (Sleeve), or "H" (Hydro Dynamic)

Noise is measured at the distance of one (1) meter from the axis of intake.

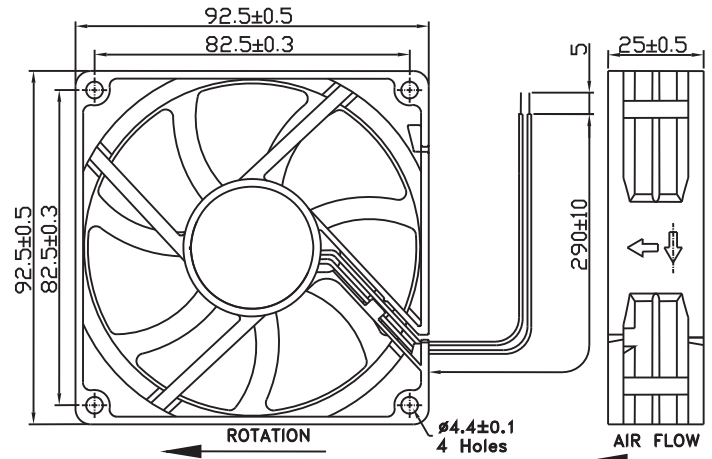
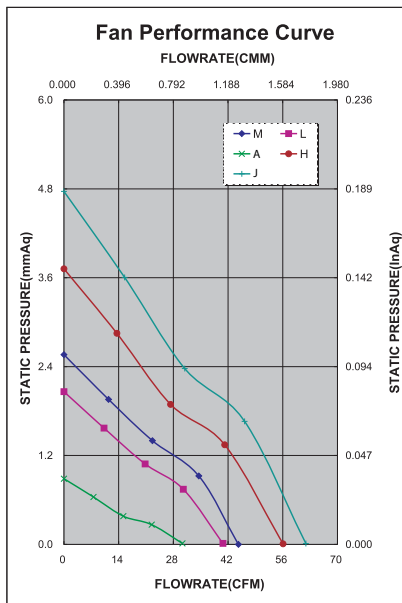

## Looking for pricing, stock, or lifecycle information?

Click below to explore more details on WIN SOURCE:

 [View FAD1-09225CBHW11 on WIN SOURCE](#)

 [Qualtek Information](#)

## Optimize Your Supply Chain with WIN SOURCE Solutions

-  Global Sourcing Solution
-  Obsolete Management
-  Cost Control Management
-  Shortage Management
-  Alternative Solution
-  Excess Inventory Management