



MMIC, LOW NOISE, SHUTDOWN FEATURE

# Monolithic Amplifier

## TSY-173LN+

50Ω 13.5 to 17 GHz

### THE BIG DEAL

- Positive Gain Slope
- Shutdown Feature
- Excellent Noise Figure, 1.2dB Typ.
- Built-In ESD Protection Circuits (Class 1C)
- Low Current Operation, 13.2mA



Generic photo used for illustration purposes only

CASE STYLE: MC1630-1

#### +RoHS Compliant

The +Suffix identifies RoHS Compliance. See our web site for RoHS Compliance methodologies and qualifications

### APPLICATIONS

- Point to Point ODU System
- Fixed Satellite
- Radio Location
- Mobile

### PRODUCT OVERVIEW

The TSY-173LN+ is a GaAs E-PHEMT based low noise MMIC Amplifier with shutdown feature with a unique combination of low noise ( 1.2dB Typ.), and Low Current (13.2mA Typ.) It is suitable for receiver application. This design operates on a single supply of 3V. It is well-matched to 50Ω and comes in a tiny, low profile package (2x2mm 6 Lead), accommodating dense circuit board layouts.

### KEY FEATURES

Feature	Advantages
Low noise, 1.2dB Typical from 13.5 - 17GHz	Enables lower system noise figure performance.
Positive Gain Slope vs. Frequency +0.6 dB/GHz from 13.5 GHz to 15 GHz +0.4 dB/GHz from 15 GHz to 17 GHz	Useful for compensating negative gain slope of most wideband microwave components and eliminating the need for equalization.
Shutdown Feature	Allow users to turn on and off the amplifier with pulsed signals while keeping the power supply at constant voltage.
Integrated DC Blocks and Bias-Tee	Saves motherboard space and minimizes overall cost. Very User Friendly.
Small Size (2x2 mm 6L MCLP)	Tiny footprint saves space in dense layouts while providing low inductance, repeatable transitions, and excellent thermal contact to the PCB.

REV. A  
ECO-011994  
TSY-173LN+  
MCL NY  
220222



ELECTRICAL SPECIFICATIONS<sup>1</sup> AT 25°C, 50Ω, UNLESS NOTED

Parameter	Condition (GHz)	Amplifier - ON			Amplifier- OFF	Units
		Min.	Typ.	Max.	Typ.	
Frequency range		13.5		17	13.5-17	GHz
Noise Figure	13.5		1.2		—	dB
	14		1.2		—	
	15		1.1		—	
	16		1.2		—	
	17		1.2		—	
Gain	13.5	14.2	15.6	17	-14.8	dB
	14		16		-14.7	
	15	15.1	16.5	18	-15.1	
	16		16.8		-15.6	
	17	15.2	16.7	18.2	-16.7	
Input Return Loss	13.5		16.4		2.6	dB
	14		18.9		2.7	
	15		18.8		3.1	
	16		15.4		3.3	
	17		16.6		3.2	
Output Return Loss	13.5		11.7		8.8	dB
	14		14.9		8.0	
	15		21.4		6.0	
	16		20.3		5.9	
	17		16		5.2	
Output P1dB (AMP-ON)	13.5		9.3		—	dBm
	14		9.4		—	
	15		8.7		—	
	16		8.4		—	
	17		6.6		—	
Output IP3 (Pout = -10 dBm/Tone)	13.5		22.4		—	dBm
	14		22.9		—	
	15		24.2		—	
	16		21.9		—	
	17		21		—	
Device Operating Voltage(VDD)		2.75	3	3.25	3	V
Device Operating Current (IDD)			13.2	19	0.00012	mA
Control Voltage (VC)		2.25	2.5	2.75	0	V
Control Current (IC)			0.56		0	mA
DC Current (IDD) Variation Vs. Temperature <sup>2</sup>			11.54		—	uA/degC
DC Current (IDD) Variation Vs. Voltage <sup>3</sup>			0.014		—	mA/mV
Thermal Resistance			106.7		—	degC/W

1. Measured on Mini-Circuits Characterization Test Board TB-TSY-173LN+. See Characterization Test & Application Circuit (Fig. 1)

2. Device Current Variation vs. Temperature= (Current in mA at 85°C - Current in mA at -45°C)/130°C

3. Device Current Variation vs. Voltage = (Current in mA at 3.25V - Current in mA at 2.75V) / ((3.25V-2.75V)\*1000 mA/mV)

MAXIMUM RATINGS<sup>4</sup>

Parameter	Ratings
Operating temperature (ground lead)	-40°C to 85°C
Storage temperature	-65°C to 150°C
Junction Temperature	130°C
Total power dissipation	0.42W
Input power (CW)	+22 dBm
DC voltage at VC	3V
DC voltage at VDD	8V

4. Permanent damage may occur if any of those limits are exceeded. Electrical maximum ratings are not intended for continuous normal operation.

## TRUTH TABLE + SWITCHING TIME SPECIFICATION

Truth Table		VC Min.	VC Typ.	VC Max.	Units
Amplifier- ON		2.25	2.5	2.75	V
Amplifier- OFF			0	0.2	V
Switching Time Parameter		Min.	Typ.	Max.	Units
Amplifier ON to OFF	OFF Time (50% Control to 10% RF)		13.7		ns
	FALL Time (90% RF to 10% RF)		8.8		ns
Amplifier OFF to ON	ON Time (50% Control to 90% RF)		52.4		ns
	RISE Time (10% RF to 90% RF)		38.8		ns
Control Voltage Leakage (Rising Edge)			0.64		mV
Control Voltage Leakage (Falling Edge)			1.45		mV



### SIMPLIFIED SCHEMATIC AND PAD DESCRIPTION

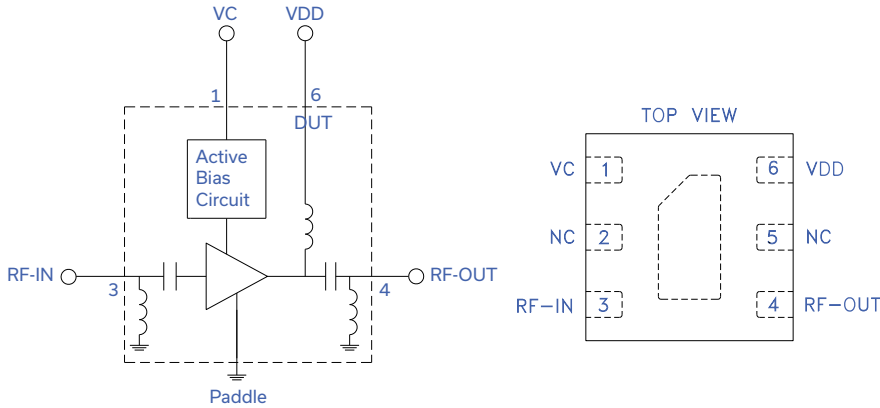

Function	Pad Number	Description (Fig 1)
VC	1	Control Voltage Pad for Shutdown (VC)
RF - IN	3	RF Input Pad
RF-OUT	4	RF Output Pad
VDD	6	DC Power Supply (VDD)
No Connection	2 & 5	Not used internally. Connected to ground on Test Board
Ground	Paddle	Soldered to Ground

### CHARACTERIZATION TEST & APPLICATION CIRCUIT

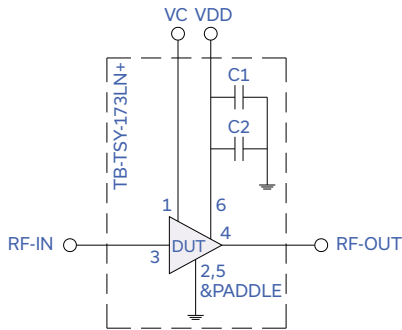

Fig 1. Application and Characterization Circuit

Note: This block diagram is used for characterization. (DUT is soldered on Mini-Circuits Characterization test board TB-TSY-173LN+)

Gain, Return loss, Output power at 1dB compression (P1dB), output IP3 (OIP3) and noise figure measured using Agilent's N5242A PNA-X microwave network analyzer.

Conditions:

1. Gain and Return loss: Pin = -25dBm
2. Output IP3 (OIP3): Two tones, spaced 1 MHz apart, -10 dBm/tone at output.
3. Switching Time: RF Signal: Pin = -10dBm, fRF = 15GHz  
VDD = 3V, VC = Pulse Signal at 100Hz with Vhigh = 2.5V and Vlow = 0V & 50% Duty Cycle.

Component	Size	Value	Part Number	Manufacturer
C1	0402	0.1uF	GRM155R71C104KA88D	Murata
C2	0402	100pF	GRM1555C1H101JA01D	Murata

### PRODUCT MARKING

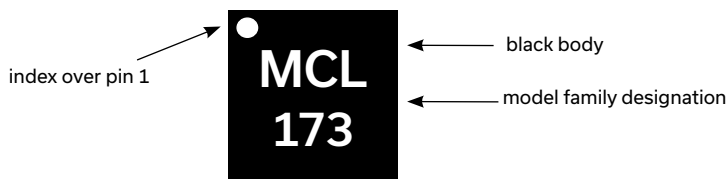

Marking may contain other features or characters for internal lot control



ADDITIONAL DETAILED TECHNICAL INFORMATION IS AVAILABLE ON OUR DASH BOARD. TO ACCESS [CLICK HERE](#)

Performance Data	Data Table
	Swept Graphs
	S-Parameter (S2P Files) Data Set (.zip file)
Case Style	MC1630-1 Plastic package, exposed paddle, lead finish: Matt Tin
Tape & Reel Standard quantities available on reel	F66 7" reels with 20, 50, 100, 200, 500 or 2K devices
Suggested Layout for PCB Design	PL-719
Evaluation Board	TB-TSY-173LN+ (Without Connectors) TB-TSY-173LNC+ (With Connectors)
Environmental Ratings	ENV08T1

### ESD RATING

Human Body Model (HBM): Class 1C (1000V) in accordance with ANSI/ESD STM 5.1 - 2001

### MSL RATING

Moisture Sensitivity: MSL1 in accordance with IPC/JEDEC J-STD-020D

### MSL TEST FLOW CHART

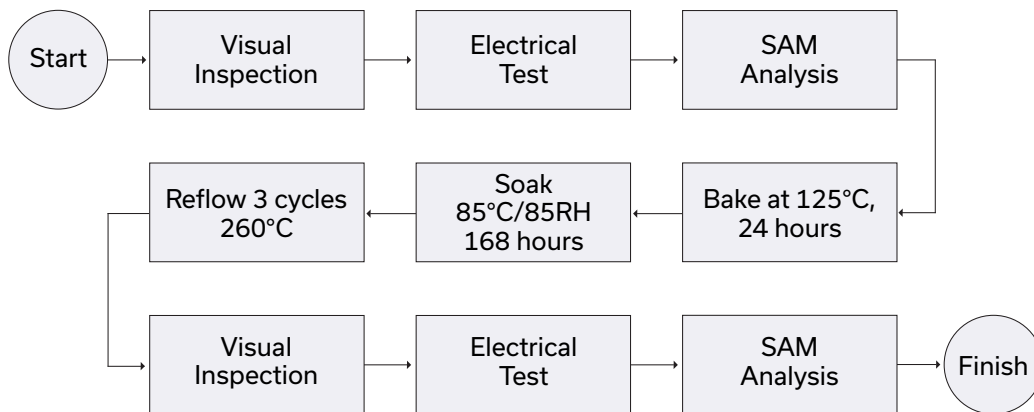

- NOTES**
- A. Performance and quality attributes and conditions not expressly stated in this specification document are intended to be excluded and do not form a part of this specification document.
  - B. Electrical specifications and performance data contained in this specification document are based on Mini-Circuit's applicable established test performance criteria and measurement instructions.
  - C. The parts covered by this specification document are subject to Mini-Circuits standard limited warranty and terms and conditions (collectively, "Standard Terms"); Purchasers of this part are entitled to the rights and benefits contained therein. For a full statement of the standard. Terms and the exclusive rights and remedies thereunder, please visit Mini-Circuits' website at [www.minicircuits.com/MCLStore/terms.jsp](http://www.minicircuits.com/MCLStore/terms.jsp)

## Looking for pricing, stock, or lifecycle information?

Click below to explore more details on WIN SOURCE:

 [View TSY-173LN+ on WIN SOURCE](#)

 [Mini-Circuits Information](#)

## Optimize Your Supply Chain with WIN SOURCE Solutions

-  Global Sourcing Solution
-  Obsolete Management
-  Cost Control Management
-  Shortage Management
-  Alternative Solution
-  Excess Inventory Management