

OPT4060 High-Speed High-Sensitivity RGBW Color Sensor

1 Features

- High-precision, high-speed color light-to-digital conversion over high-speed I²C interface
- Four channel sensing using precision optical filters:
 - Three channels with peak responses in red, green and blue wavelengths and >99.99% NIR rejection (850 nm)
 - Clear wide bandwidth channel
- High resolution RGB color measurement
- Semi-logarithmic output with seven binary logarithmic full-scale light range and highly linear response within each range
- Built-in automatic full-scale light range selection logic, which switches measurement range based on input light condition with excellent gain matching between ranges
- 26 bits of effective dynamic range from 2.15 mlux to 144 klux
- 12 configurable conversion times from 600 μs to 800 ms per channel is an excellent choice for a wide variety of high speed and high precision applications
- External pin interrupt for hardware synchronized trigger and interrupts
- Low operating current: 24 μA
- Ultra-low power standby: 2 μA
- Operating temperature range: –40°C to +85°C
- Wide power-supply range: 1.6 V to 3.6 V
- 5.5-V Tolerant I/Os
- Selectable I²C address
- Small-form factor:
 - 2.1 mm × 1.9 mm × 0.6 mm SOT-5X3 package

2 Applications

- [Display brightness and color adjustments](#)
- Camera image correction
- Auto white balancing
- [Building automation and control](#)
- [Lighting control systems](#)
- [Tablet and notebook computers](#)

3 Description

The OPT4060 is a single-chip high resolution color sensor, capable of measuring four channels each with specific engineered spectral responses. Three of the four channels have peak spectral responses in the red, green and blue wavelengths with the fourth channel having a wide band spectral response. With measurements from these channels, important characteristics of the lighting environment can be extracted like (i) light intensity (lux) and (ii) color. The OPT4060 is available in a small SOT-5X3 package.

The OPT4060 has a selectable addressing scheme to enable up to four devices on a shared I²C bus. The spectral response of the channels have been specially tuned for color detection, with strong rejection for wavelengths away from their respective peaks, especially the NIR (850 nm and 940 nm) region. The filters use an advanced filter technology which provides excellent filter performance even at higher angles of light incidence.

Package Information

PART NUMBER	PACKAGE ⁽¹⁾	PACKAGE SIZE (NOM) ⁽²⁾
OPT4060	DTS (SOT-5X3, 8)	2.10 mm × 1.90 mm × 0.6 mm

- (1) For all available packages, see the package option addendum at the end of the data sheet.
- (2) The package size (length × width) is a nominal value and includes pins, where applicable.

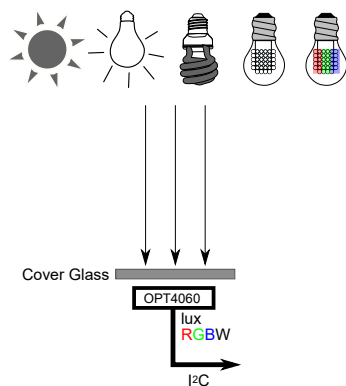

Typical Application Diagram

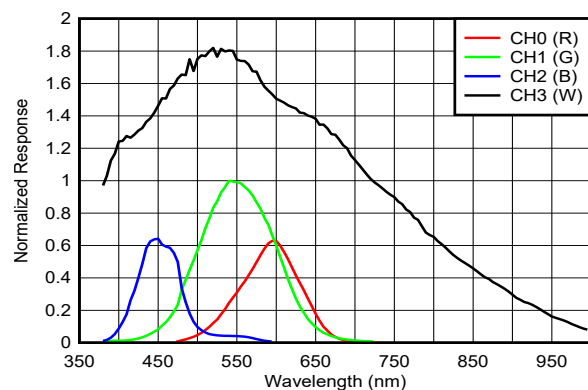

Normalized Spectral Response



Table of Contents

1 Features	1	8.5 Programming.....	18
2 Applications	1	8.6 Register Maps.....	24
3 Description	1	9 Application and Implementation	35
4 Revision History	2	9.1 Application Information.....	35
5 Description (continued)	3	9.2 Typical Application.....	35
6 Pin Configuration and Functions	3	9.3 Best Design Practices.....	37
7 Specifications	4	9.4 Power Supply Recommendations.....	38
7.1 Absolute Maximum Ratings.....	4	9.5 Layout.....	38
7.2 ESD Ratings.....	4	10 Device and Documentation Support	40
7.3 Recommended Operating Conditions.....	4	10.1 Documentation Support.....	40
7.4 Thermal Information.....	4	10.2 Receiving Notification of Documentation Updates.....	40
7.5 Electrical Characteristics.....	4	10.3 Support Resources.....	40
7.6 Typical Characteristics.....	7	10.4 Trademarks.....	40
8 Detailed Description	9	10.5 Electrostatic Discharge Caution.....	40
8.1 Overview.....	9	10.6 Glossary.....	40
8.2 Functional Block Diagram.....	10	11 Mechanical, Packaging, and Orderable Information	40
8.3 Feature Description.....	10		
8.4 Device Functional Modes.....	11		

4 Revision History

NOTE: Page numbers for previous revisions may differ from page numbers in the current version.

DATE	REVISION	NOTES
June 2023	*	Initial release.

5 Description (continued)

The engineered optical filter on OPT4060 provides strong infrared rejection, which aids in maintaining high accuracy, despite placing the sensor under dark glass, which is a common requirement from the industrial design of end products due to aesthetics.

The OPT4060 is designed for systems that require light level detection to enhance user experience by providing information not only about the intensity, but the color of the illumination.

The OPT4060 device can be configured to operate with light conversion times all the way from 600 μ s to 800 ms in 12 steps per channel, providing system flexibility based on application need. Conversion time includes the light integration time and ADC conversion time. Resolution of the measurement is determined by a combination of light intensity and the integration time, effectively bringing in capability to measure down to 2.15 mlux.

The digital operation is flexible for system integration. Measurements can be either continuous or triggered in one shots with register writes or hardware pin. The device features a threshold detection logic, which allows the processor to sleep while the sensor watches for appropriate wake-up event to report through the interrupt pin.

Digital output, representing the light level is reported over an I²C and SMBus compatible, two-wire serial interface.

The low power consumption and low power-supply voltage capability of the OPT4060 helps enhance the battery life of battery-powered systems.

6 Pin Configuration and Functions

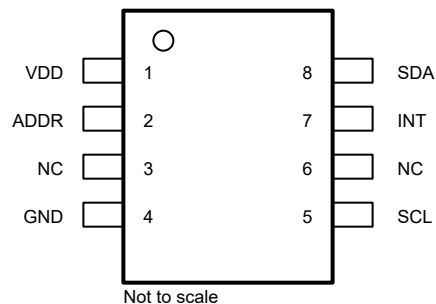

Figure 6-1. DTS Package, 8-Pin SOT-5X3, Top View

Table 6-1. Pin Functions

PIN		TYPE	DESCRIPTION
NO.	NAME		
1	VDD	Power	Device power. Connect to a 1.6-V to 3.6-V supply.
2	ADDR	Digital input	Address pin. This pin sets the least significant bits (LSBs) of the I ² C address.
3	NC	No Connection	No Connection
4	GND	Power	Ground
5	SCL	Digital input	I ² C clock. Connect with a 10-k Ω resistor to a 1.6-V to 5.5-V supply.
6	NC	No Connection	No Connection
7	INT	Digital I/O	Interrupt input/output open-drain. Connect with a 10-k Ω resistor to a 1.6-V to 5.5-V supply.
8	SDA	Digital I/O	I ² C data. Connect with a 10-k Ω resistor to a 1.6-V to 5.5-V supply.

7 Specifications

7.1 Absolute Maximum Ratings

over operating free-air temperature range (unless otherwise noted)⁽¹⁾

		MIN	MAX	UNIT
Voltage	VDD to GND	-0.5	6	V
	SDA and SCL to GND	-0.5	6	V
Current in to any pin			10	mA
T _J	Junction temperature		150	°C
T _{stg}	Storage temperature	-65	150 ⁽²⁾	°C

- Operation outside the Absolute Maximum Ratings may cause permanent device damage. Absolute Maximum Ratings do not imply functional operation of the device at these or any other conditions beyond those listed under Recommended Operating Conditions. If used outside the Recommended Operating Conditions but within the Absolute Maximum Ratings, the device may not be fully functional, and this may affect device reliability, functionality, performance, and shorten the device lifetime.
- Long exposure to temperatures higher than 105°C can cause package discoloration, spectral distortion, and measurement inaccuracy.

7.2 ESD Ratings

			VALUE	UNIT
V _(ESD)	Electrostatic discharge	Human body model (HBM), per ANSI/ESDA/ JEDEC JS-001, all pins ⁽¹⁾	±2000	V
		Charged device model (CDM), per ANSI/ESDA/ JEDEC JS-002, all pins ⁽²⁾	±500	

- JEDEC document JEP155 states that 500-V HBM allows safe manufacturing with a standard ESD control process.
- JEDEC document JEP157 states that 250-V CDM allows safe manufacturing with a standard ESD control process.

7.3 Recommended Operating Conditions

over operating free-air temperature range (unless otherwise noted)

		MIN	NOM	MAX	UNIT
VDD	Supply voltage	1.6		3.6	V
T _J	Junction temperature	-40		85	°C

7.4 Thermal Information

THERMAL METRIC ⁽¹⁾		OPT4060	UNIT
		DTS (SOT-5X3)	
		8 PINS	
R _{θJA}	Junction-to-ambient thermal resistance	112.2	°C/W
R _{θJC(top)}	Junction-to-case (top) thermal resistance	28.4	°C/W
R _{θJB}	Junction-to-board thermal resistance	22.1	°C/W
Ψ _{JT}	Junction-to-top characterization parameter	1.2	°C/W
Ψ _{JB}	Junction-to-board characterization parameter	22	°C/W

- For more information about traditional and new thermal metrics, see the [Semiconductor and IC Package Thermal Metrics](#) application report.

7.5 Electrical Characteristics

All specifications at T_A = 25°C, V_{DD} = 3.3 V, 800-ms conversion-time per channel (CONVERSION_TIME=0xB), automatic full-scale range (RANGE = 0xC), white LED and normal-angle incidence of light, unless otherwise specified.

PARAMETER	TEST CONDITIONS	MIN	TYP	MAX	UNIT
Optical					

7.5 Electrical Characteristics (continued)

All specifications at $T_A = 25^\circ\text{C}$, $V_{DD} = 3.3\text{ V}$, 800-ms conversion-time per channel (CONVERSION_TIME=0xB), automatic full-scale range (RANGE = 0xC), white LED and normal-angle incidence of light, unless otherwise specified.

PARAMETER		TEST CONDITIONS	MIN	TYP	MAX	UNIT
	Number of Channels			4		
λ_{peak}	Peak irradiance spectral responsivity	CH0 (R)		605		nm
		CH1(G)		555		nm
		CH2(B)		450		nm
		CH3(W)		500		nm
	ADC resolution		9		20	bits
	Range determination			3		bits
T_{intg}	Light Integration-time per channel ⁽⁴⁾	Conversion-time CT = 0x6		25		ms
		Conversion-time CT = 0xB		800		ms
R_{CH0}	Peak Responsivity	CH0 (R) Lowest auto gain range, 800ms conversion time per channel		1950		codes per $\mu\text{W}/\text{cm}^2$
R_{CH1}		CH1 (G) Lowest auto gain range, 800ms conversion time per channel		3100		codes per $\mu\text{W}/\text{cm}^2$
R_{CH2}		CH2 (B) Lowest auto gain range, 800ms conversion time per channel		1990		codes per $\mu\text{W}/\text{cm}^2$
R_{CH3}		CH3 (W) Lowest auto gain range, 800ms conversion time per channel		5640		codes per $\mu\text{W}/\text{cm}^2$
ER_{lux}	Equivalent Resolution	Lowest auto gain range, 100ms conversion-time per channel		17.2		mlux
		Lowest auto gain range, 800ms conversion-time per channel		2.15		mlux
E_{VFS}	Full-scale equivalent Illuminance			144284		lux
E_{v}	Measurement output result from lux measurement	2000 lux input ⁽¹⁾	1800	2000	2200	lux
	Relative accuracy between gain ranges ⁽²⁾	All channels		0.6		%
E_{VIR}	Infrared response ⁽⁶⁾	850nm near infra-red, all channels except for CH3 (W)		0.2		%
	Light source variation for lux measurement (incandescent, halogen, fluorescent)	Bare device, no cover glass		4		%
	Linearity	Input illuminance > 2254 lux , 100ms conversion-time per channel, all channels		2		%
		Input illuminance <= 2254lux , 100ms conversion-time per channel, all channels			5	
	Dark Measurement	All channels		0	10	codes
	Drift across temperature	CH0 (R)		0.02		%/°C
		CH1 (G)		0.02		%/°C
		CH2 (B)		0.05		%/°C
		CH3 (W)		0.05		%/°C
	Angular response (FWHM)	CH0 (R)		134		°
		CH1 (G)		121		°
		CH2 (B)		99		°
		CH3 (W)		128		°

7.5 Electrical Characteristics (continued)

All specifications at $T_A = 25^\circ\text{C}$, $V_{DD} = 3.3\text{ V}$, 800-ms conversion-time per channel (CONVERSION_TIME=0xB), automatic full-scale range (RANGE = 0xC), white LED and normal-angle incidence of light, unless otherwise specified.

PARAMETER		TEST CONDITIONS	MIN	TYP	MAX	UNIT
PSRR	Power-supply rejection ratio ⁽³⁾	VDD at 3.6 V and 1.6 V, 30 different sources, all channels		0.2		%/V
POWER SUPPLY						
V_{DD}	Power supply		1.6		3.6	V
V_{I2C}	Power supply for I ² C pull up resistor	I ² C pullup resistor, $V_{DD} \leq V_{I2C}$	1.6		5.5	V
$I_{QACTIVE}$	Active Current	Dark		24		μA
		Full-scale lux		29		μA
I_Q	Quiescent current	Dark		2		μA
		Full-scale lux		2.6		μA
POR	Power-on-reset threshold			0.8		V
DIGITAL						
C_{IO}	I/O Pin Capacitance			3		pF
V_{IL}	Low-level input voltage (SDA, SCL, and ADDR)		0		$0.3 \times V_{DD}$	V
V_{IH}	High-level input voltage (SDA, SCL, and ADDR)		$0.7 \times V_{DD}$		5.5	V
I_{IL}	Low-level input current (SDA, SCL, and ADDR)			0.01	$0.25^{(5)}$	μA
V_{OL}	Low-level output voltage (SDA and INT)	$I_{OL} = 3\text{mA}$			0.32	V
I_{ZH}	Output logic high, high-Z leakage current (SDA, INT)	Measured with V_{DD} at pin		0.01	$0.25^{(5)}$	μA
TEMPERATURE						
	Specified temperature range		-40		85	$^\circ\text{C}$

- (1) Tested with the white LED calibrated to 2000 lux
- (2) Characterized by measuring fixed near-full-scale light levels on the higher adjacent full-scale range setting.
- (3) PSRR is the percent change of the measured lux output from its current value, divided by the change in power supply voltage, as characterized by results from 3.6-V and 1.6-V power supplies
- (4) The conversion-time, from start of conversion until the data are ready to be read, is the integration-time plus analog-to-digital conversion-time.
- (5) The specified leakage current is dominated by the production test equipment limitations. Typical values are much smaller
- (6) Tested with a near infrared LED of 850nm wavelength

7.6 Typical Characteristics

At $T_A = 25^\circ\text{C}$, $V_{DD} = 3.3\text{ V}$, 800-ms conversion time (CONVERSION_TIME = 0xB), automatic full-scale range (RANGE = 0xC), white LED, and normal-angle incidence of light, unless otherwise specified.

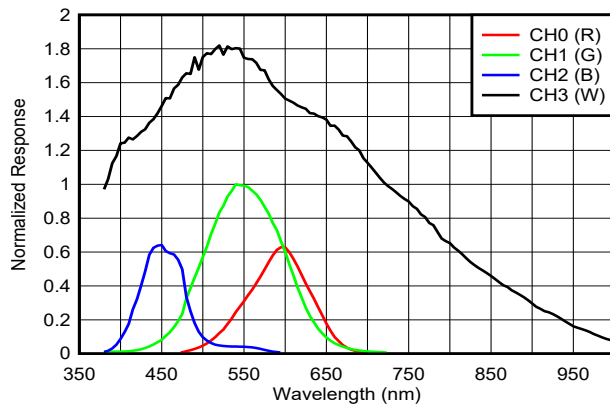

Normalized to green channel peak

Figure 7-1. Spectral Response vs Wavelength

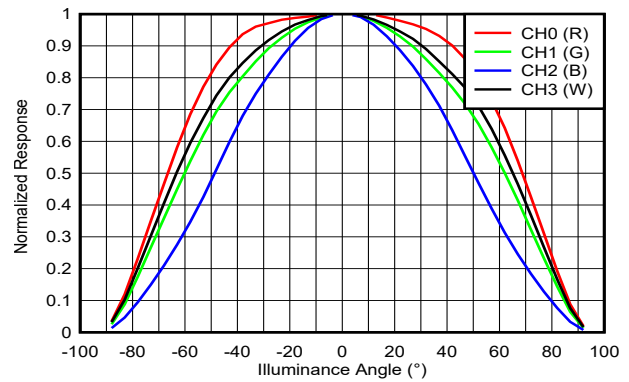

Normalized to 0°

Figure 7-2. Device Response vs Illuminance Angle

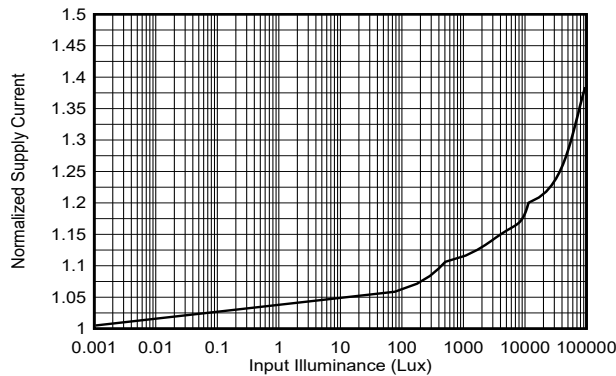

Normalized to dark condition

Figure 7-3. Active Current vs Input Light Level

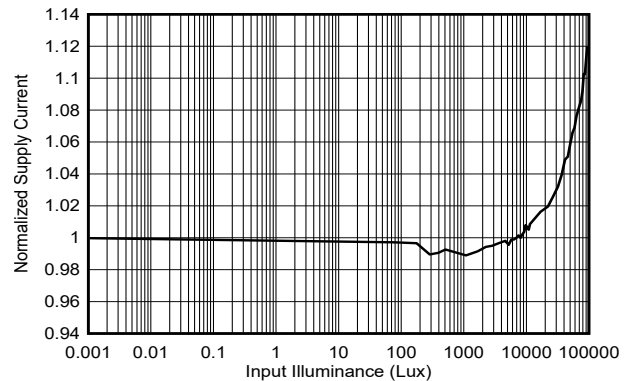

Normalized to dark condition

Figure 7-4. Standby Current vs Input Light Level

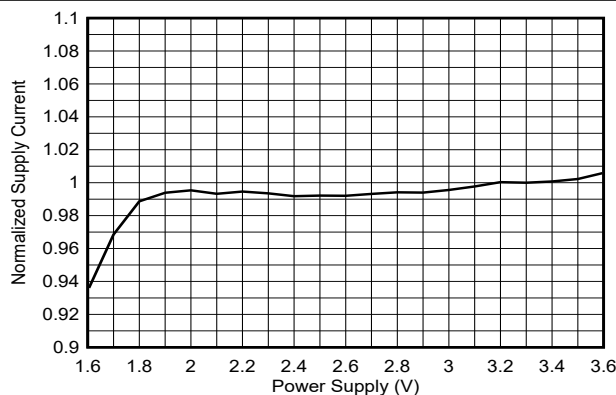

Normalized to 3.3 V

Figure 7-5. Active Current vs Power Supply

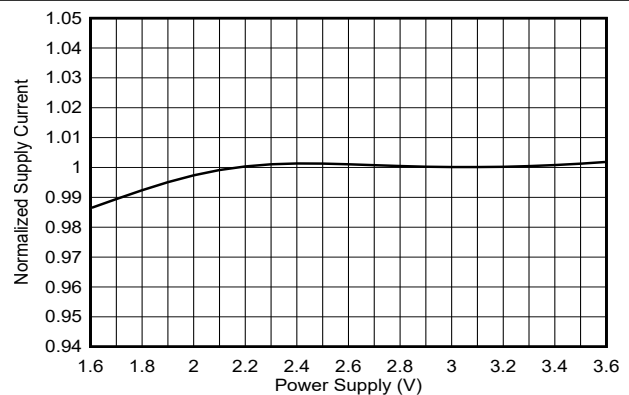

Normalized to 3.3 V

Figure 7-6. Standby Current vs Power Supply

7.6 Typical Characteristics (continued)

At $T_A = 25^\circ\text{C}$, $V_{DD} = 3.3\text{ V}$, 800-ms conversion time (CONVERSION_TIME = 0xB), automatic full-scale range (RANGE = 0xC), white LED, and normal-angle incidence of light, unless otherwise specified.

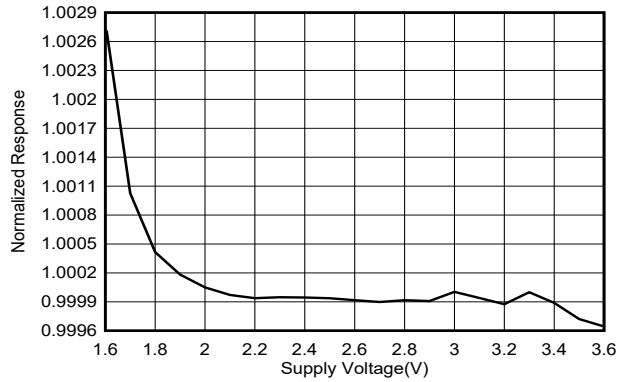

Normalized to 3.3 V

Figure 7-7. Device Response vs Power Supply

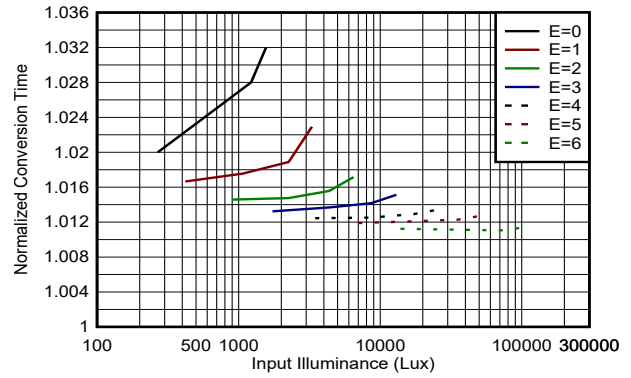

E denotes register EXPONENT_CHx
Normalized to 25 ms

Figure 7-8. Conversion Time at 25 ms per channel vs Input Light Level

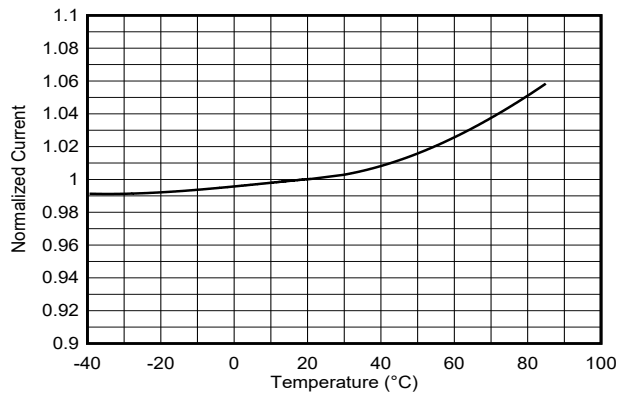

Normalized to 25°C

Figure 7-9. Active Current vs Temperature

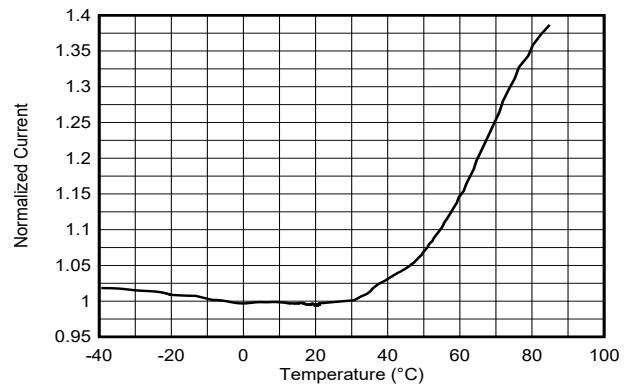

Normalized to 25°C

Figure 7-10. Standby Current vs Temperature

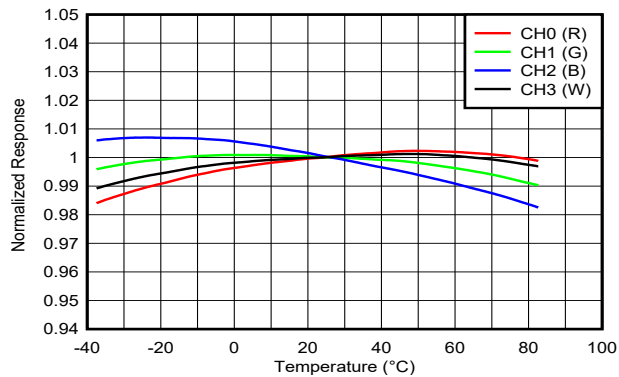

Normalized to 25°C

Figure 7-11. Device Response vs Temperature

8 Detailed Description

8.1 Overview

The OPT4060 measures the color properties of the light source that illuminates the device. This device measures four channels (R Channel, G Channel, B Channel, W Channel) with special spectral characteristics, which helps extract properties of the light source (i) the lux level and (ii) the correlated color temperature. Each channel (R, G, B) is named for the color it is sensitive to. The additional W channel has a wide spectral response.

With engineered spectral profiles, the OPT4060 measures the intensity and color of any light source or environment. This helps applications where measuring the precise characteristics of the lighting environment is critical like display brightness, color adjustment, camera color correction and object color recognition. Strong rejection of infrared light, which a human does not see, makes the OPT4060 especially good for operation underneath windows that are visibly dark, but infrared transmissive

The OPT4060 is fully self-contained to measure the properties of light and report the result in ADC codes digitally over the I²C bus. The result can also be used to alert a system and interrupt a processor with the INT pin. The result can also be summarized with a programmable threshold comparison with a specified channel and communicated with the INT pin.

The OPT4060 is by default configured to operate in automatic full-scale range detection mode that always selects the best full-scale range setting for the given lighting conditions. There are seven full-scale range settings, one of which can be selected manually as well. Setting the device to operate in automatic full-scale range detection mode frees the user from having to program their software for potential iterative cycles of measurement and readjustment of the full-scale range until good for any given measurement. With device exhibiting linearity over the entire 26-bit dynamic range of measurement, no additional linearity calibration is required at system level.

The OPT4060 contains four channels, results of which are always available all the time as independent channel registers which can be digitally read over the I²C bus synchronously or asynchronously.

The device measures light for four channels sequentially (R, G, B, W) with selectable conversion times from 600 μ s per channel to 800 ms per channel in 12 steps. Measurements can be read asynchronously or through the interrupt pin, which can be configured to generate an interrupt every time a single channel completes conversion or every time all four channels complete conversion.

The device starts up in a low-power shutdown state, such that the OPT4060 only consumes active-operation power after being programmed into an active state.

The OPT4060 optical filtering system is not excessively sensitive to small particles and micro-shadows on the optical surface. This reduced sensitivity is a result of the relatively minor device dependency on uniform density optical illumination of the sensor area for infrared rejection. Proper optical surface cleanliness is always recommended for best results on all optical devices.

8.2 Functional Block Diagram

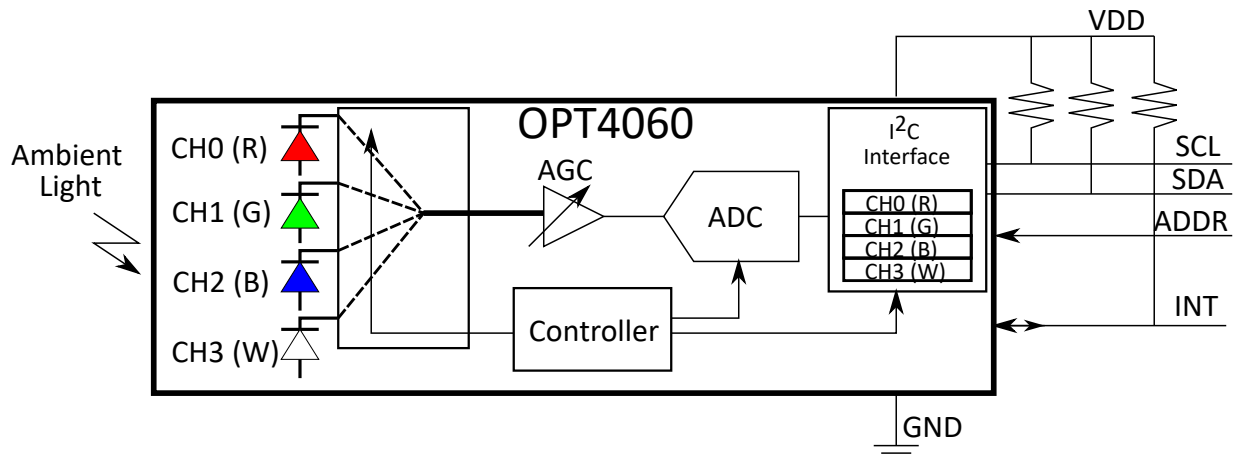

8.3 Feature Description

8.3.1 Infrared Light Rejection

The OPT4060 also has excellent infrared light (IR) rejection. This IR rejection is especially important because many real-world lighting sources have significant infrared content that humans do not see. If the sensor measures infrared light that the human eye does not see, then a true human experience is not accurately represented.

If the application must hide the OPT4060 underneath a dark window (such that the end-product user cannot see the sensor) the infrared rejection of the OPT4060 becomes significantly more important because many dark windows attenuate visible light but transmit infrared light. This attenuation of visible light and lack of attenuation of IR light amplifies the ratio of the infrared light to visible light that illuminates the sensor. Results can still be well matched to the specified R, G, and B curves under this condition because of the high infrared rejection of the OPT4060.

8.3.2 Automatic Full-Scale Range Setting

The OPT4060 has an automatic full-scale range setting feature that eliminates the need to predict and set the best range for the device. Each channel has a auto-scaling algorithm and independently tracks light levels. In this mode, the OPT4060 automatically selects the best full-scale range for the given lighting condition. The OPT4060 has a high degree of result matching between the full-scale range settings. This matching eliminates the problem of varying results or the need for range-specific, user-calibrated gain factors when different full-scale ranges are chosen. The device has independent range detection logic making the device operate seamlessly with a wide range of light color and levels.

8.3.3 Output Register CRC and Counter

The OPT4060 device features additional bits as part of the output register which helps in improving the reliability of light measurements for the application.

8.3.3.1 Output Sample Counter

The OPT4060 device features registers `COUNTER_CHx` as part of the output registers which increments for every successful measurement. This register can be read as part of the output registers which helps the application to keep track of measurements. The 4 bit counter starts at 0 on power-up and counts up to 15 after which the counter resets back to 0 and continues to count up. There are independent counters for each channel counting up every successful conversion.

- Host or the controller needs consecutive measurements. Utilizing the `COUNTER_CHx` registers allow the controller to compare samples and makes sure that the samples are in expected order without missing intermediate counter values.

- As a safety feature where when light level are not changing, the controller can make sure that the measurements from OPT4060 are not stuck by comparing values of registers [COUNTER_CHx](#) between measurements. If the [COUNTER_CHx](#) values continue to change over samples, the device is updating the output register with the most recent measurement of light levels.

8.3.3.2 Output CRC

[CRC_CHx](#) registers consists of Cyclic Redundancy Checker bits part of the output registers calculated within the OPT4060 device and updated on every measurement. This feature helps in detecting communication related bit errors during the output readout from the device. [Figure 8-12](#) shows the calculation method for the CRC bits, which can be independently verified in the controller or host firmware or software to validate if communication between the controller and the device was successful without bit errors during transmission.

8.3.3.3 Threshold Detection

The OPT4060 features a threshold detection logic which can be programmed to indicate and update register flags if measured light levels cross thresholds set by the user. The threshold condition can be programmed to use one of the four channels as a trigger as determined by the [THRESHOLD_CH_SEL](#) register. There are independent low and high threshold target registers with independent flag registers to indicate the status of measured light level. Measured light level reaching below low threshold and above the high threshold are called faults. Users can program a fault count register, which counts consecutive number of faults before the flag registers are set. See [Interrupt Modes of Operation](#) and [Light and Color Measurement](#) for more information on the register and setting up the threshold.

8.4 Device Functional Modes

8.4.1 Modes of Operation

The OPT4060 has [output registers](#) which are always available to readout to get measurements, the measurements themselves are updated based on the device mode of operation listed as follows. The OPT4060 device has the following modes of operation:

- **Power-down mode:** This is power-down or standby mode where the device enters a low power state. There is no active light sensing or conversion in this mode. Device still responds to I²C transactions which can be used to bring the device out of this mode.
- **Continuous mode:** In this mode OPT4060 measures all four channels in a round-robin fashion continuously and updates their corresponding output registers. The conversion time register [CONVERSION_TIME](#) determines the time between each channel conversion and a hardware interrupt on pin INT is generated for every successful conversion on each channel or all four channels depending on [INT_CFG](#) register value. TI recommends to configure the INT pin in output mode using the [INT_DIR](#) register. The device active circuits are continuously kept active to minimize the interval between measurements.
- **One shot mode of operation:** There are several ways in which the OPT4060 can be used in one shot mode of operation with the common theme which is that the OPT4060 stays in standby mode and a conversion is triggered either by a register write to the configuration register or a hardware interrupt on the INT pin. Every trigger generates one measurement for four channels, effectively taking four times the time set by the [CONVERSION_TIME](#) register

There are two types of one shot modes.

- **Force auto-range one shot mode:** Every one shot trigger forces a full reset on auto-ranging control logic and a fresh auto-range detection is initiated ignoring the previous measurements. This is particularly useful in situation where lighting conditions are expected to change a lot and one shot trigger frequency is not very often. There is small penalty on conversion time due for the auto-ranging logic to recover from reset state. The full reset cycle on the auto-ranging control logic takes around 500 μs which needs to be accounted for between measurements when this mode is used.
- **Regular auto-range one shot mode:** Auto-range selection logic utilizes the information from the previous measurements to decide on range for the current trigger. This mode is recommended only when the device needs time synchronized measurements with frequent triggers from the controller. In other words, this mode can be used as an alternative to continuous mode the key difference being that the interval between measurements is determined by the one shot triggers.

Users can trigger one shot mode through the following:

- **Hardware trigger:** the INT pin can be configured to be an input to trigger a measurement using the [INT_DIR](#) register. The INT pin is used as input, therefore there is no hardware interrupt to indicate completion of measurement. The controller must keep time from the trigger mechanism and read out output registers.
- **Register trigger:** An I²C write to the M register triggers a measurement. The register value is reset after a successful measurement. INT pin can be configured to indicate measurement completion to read out output registers using the [INT_DIR](#) register.

TI highly recommends to set the interval between subsequent triggers to account for all the aspects involved in the trigger mechanism like the I²C transaction time, device wake-up time, auto-range time (if used) and 4 times the device conversion time.

The device enters standby after each one shot trigger, therefore measurement interval on the one shot trigger mechanism must account for additional time T_{SS} as specified in the specification table for the circuits to recover from standby state. However, setting the quick wake-up register QWAKE eliminates the need for this additional T_{SS} at the cost of not powering down the active circuit with device not entering the standby mode between triggers.

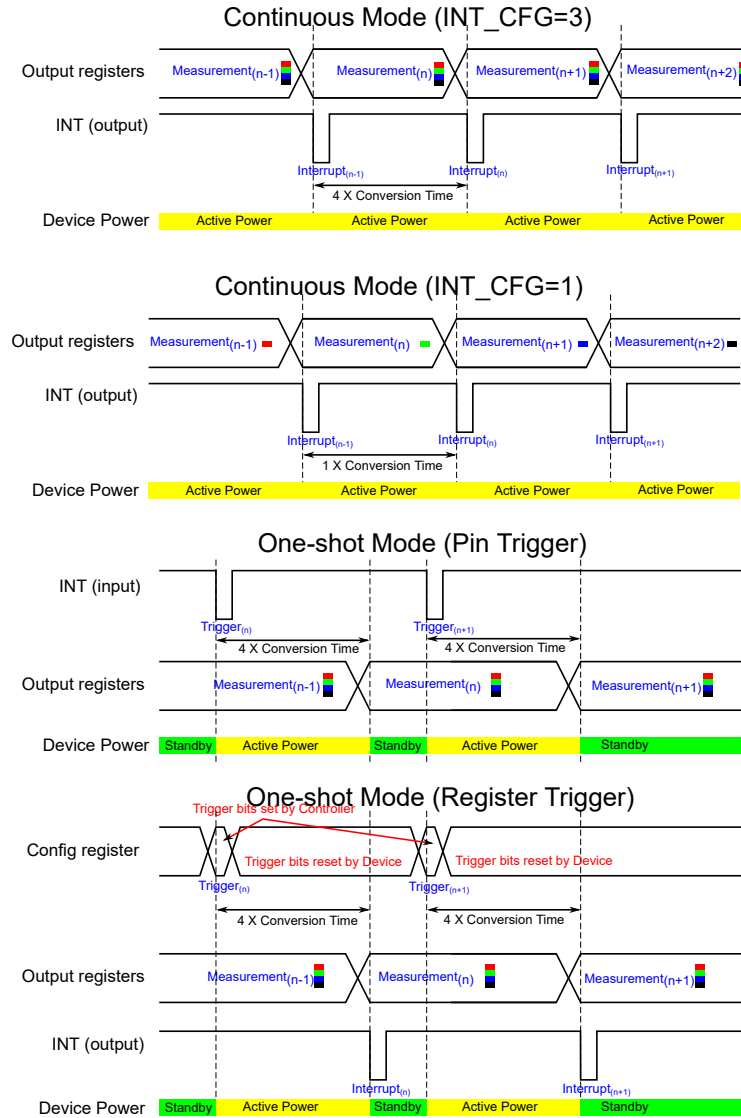

Figure 8-1. Timing Diagrams for Different Operating Modes

8.4.2 Interrupt Modes of Operation

The device has an interrupt reporting system that allows the processor connected to the I²C bus to go to sleep, or otherwise ignore the device results, until a user-defined event occurs that requires possible action. Alternatively, this same mechanism can also be used with any system that can take advantage of a single digital signal that indicates whether the light is above or below levels of interest.

The channel on which to enable this behavior is set by the register [THRESHOLD_CH_SEL](#).

The INT pin has an open-drain output, which requires the use of a pull-up resistor. This open-drain output allows multiple devices with open-drain INT pins to be connected to the same line, thus creating a logical *NOR* or *AND* function between the devices. The polarity of the INT pin can be controlled by the [INT_POL](#) register.

There are two major types of interrupt reporting mechanism modes: latched window comparison mode and transparent hysteresis comparison mode. The configuration register [LATCH](#) controls which of these two modes is used. [Figure 8-2](#) and [Table 8-1](#) summarize the function of these two modes. Additionally, the INT pin can either be used to indicate a fault in one of these modes ([INT_CFG=0](#)) or to indicate a conversion completion ([INT_CFG >0](#)). This is shown in [Table 8-2](#).

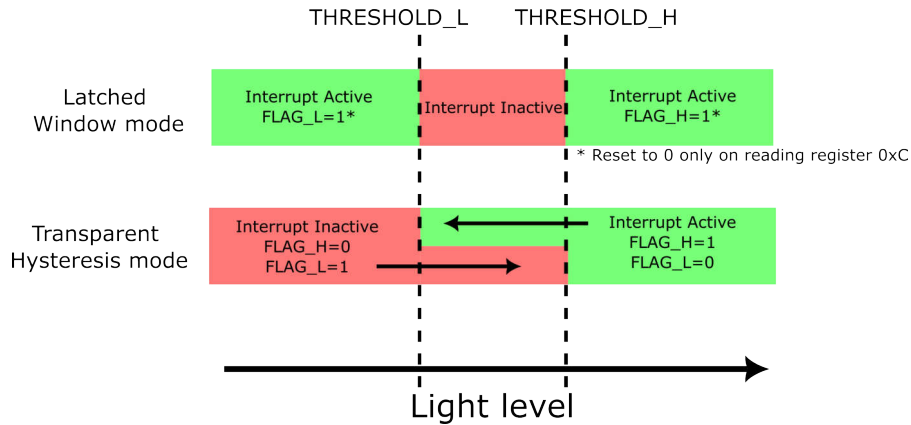

Figure 8-2. Interrupt Pin Status (for INT_CFG=0 setting) and Register Flag Behavior

Table 8-1. Interrupt Pin Status (for INT_CFG=0 Setting) and Register Flag Behavior

LATCH SETTING	INT PIN STATE (WHEN INT_CFG=0)	FLAG_H VALUE	FLAG_L VALUE	LATCHING BEHAVIOR
0: Transparent hysteresis mode	INT pin indicates if measurement is above (INT active) or below (INT inactive) the threshold. If measurement is between the high and low threshold values then the previous INT value is maintained. This prevents the INT pin from repeated toggling when the measurement values are close to the threshold.	0: If measurement is below the low limit 1: If measurement is above the high limit If measurement is between high and low limits previous value is maintained	0: If measurement is below the high limit 1: If measurement is above the low limit If measurement is between high and low limits previous value is maintained	Not latching: Values are updated after each conversion
1: Latched window mode	INT pin becomes active if the measurement is outside the window (above high threshold or below the low threshold). The INT pin does not reset and return to the inactive state until register 0xC is read.	1: If measurement is above the high limit	1: If measurement is below the low limit	Latching: INT pin, FLAG_H and FLAG_L values do not reset until the register 0x0C is read.

The [THRESHOLD_H](#), [THRESHOLD_L](#), [LATCH](#) and [FAULT_COUNT](#) registers control the interrupt behavior. The [LATCH](#) field setting allows a choice between the latched window mode and transparent hysteresis mode as shown in the table. Interrupt reporting can be observed on INT pin, the [FLAG_H](#), and the [FLAG_L](#) registers.

Results from comparing the current sensor measurements with [THRESHOLD_H](#) and [THRESHOLD_L](#) registers are referred to as *fault events*. [Light and Color Measurement](#) shows the calculations to set these registers. The [FAULT_COUNT](#) register dictates the number of continuous *fault events* required to trigger an interrupt event and subsequently change the state of the interrupt reporting mechanisms. For example, with a [FAULT_COUNT](#) value of 2 corresponding to 4 fault counts, the INT pin, [FLAG_H](#) and [FLAG_L](#) states shown in the table are not realized unless 4 consecutive measurements are taken that satisfy the fault condition.

INT pin function listed in [Table 8-1](#) is valid only when [INT_CFG=0](#). The INT pin function can be changed to indicate an end of conversion as well shown in [Table 8-2](#). The [FLAG_H](#) and [FLAG_L](#) registers continue to behave as listed in [Table 8-1](#) even while [INT_CFG>0](#). The polarity of the INT pin is controlled by the [INT_POL](#) register.

Table 8-2. INT_CFG Setting and Resulting INT Pin Behavior

INT_CFG SETTING	INT PIN FUNCTION
0	As per Table 8-1

Table 8-2. INT_CFG Setting and Resulting INT Pin Behavior (continued)

INT_CFG SETTING	INT PIN FUNCTION
1	INT pin asserted with 1- μ s pulse width after conversion of every channel
3	INT pin asserted with 1- μ s pulse width every 4 conversions to indicate all channel measurements are complete

8.4.3 Light Range Selection

The OPT4060 has an automatic full-scale-range setting mode that eliminates the need for a user to predict and set the best range for the device. Set register [RANGE](#) to 0xC to enter this mode. The device determines the appropriate full-scale range to take the measurement based on a combination of current lighting conditions and the previous measurement.

If a measurement is towards the low side of full-scale, then the full-scale range is decreased by one or two settings for the next measurement. If a measurement is towards the upper side of full-scale, the full-scale range is increased by one setting for the next measurement.

If the measurement exceeds the full-scale range, resulting from a fast increasing optical transient event, then the current measurement is aborted. This invalid measurement is not reported. If the scale is not at the maximum, then the device increases the scale by one step and a new measurement is retaken with that scale. Therefore, during a fast increasing optical transient in this mode, a measurement can possibly take longer to complete and report than indicated by the configuration register [CONVERSION_TIME](#).

The logic that determines the appropriate range settings for each channel is independent of each other, which verifies a support of a wide range of colors represented with the best accuracy.

TI highly recommends to use this feature, since the device selects the best range setting based on lighting condition. However, there is an option to manually set the range. Setting the range manually turns off the automatic full-scale selection logic and the device operates for a particular range setting.

Table 8-3. Range Selection Table

RANGE REGISTER SETTING	TYPICAL FULL-SCALE LIGHT LEVEL
0	2254 lux
1	4509 lux
2	9018 lux
3	18036 lux
4	36071 lux
5	72142 lux
6	144284 lux
12	Determined by automatic full-scale range logic

8.4.4 Selecting Conversion Time

The OPT4060 device offers several conversion times the user can select. Conversion Time is defined as the time to take for one measurement to complete for one channel and update the results in output register. The OPT4060 is 4-channel device, therefore the actual time to complete a 4-channel measurement is 4 times the time specified in the [CONVERSION_TIME](#) register. Measurement initiation is determined by the mode of operation as specified in [Modes of Operation](#).

Table 8-4. Conversion Time Selection

CONVERSION_TIME REGISTER	TYPICAL CONVERSION TIME PER CHANNEL
0	600 μ s
1	1 ms
2	1.8 ms
3	3.4 ms
4	6.5 ms
5	12.7 ms
6	25 ms
7	50 ms
8	100 ms
9	200 ms
10	400 ms
11	800 ms

8.4.5 Light and Color Measurement

The OPT4060 device measures light on four independent channels and updates output registers with proportional ADC codes. Updates are based on the mode of operation as described in [Modes of Operation](#). If readout of output registers is performed before a successful completion of a measurement, the previous measurement is what would be read out. Output of the each channel is represented by two parts (i) four bits of EXPONENT_CHx and (ii) 20 bits of MANTISSA_CHx. This arrangement of binary logarithmic full-scale range with linear representation within a range, helps in covering a large dynamic range of measurements. MANTISSA here represents the linear ADC codes proportional to the measured light within a given full-scale range and the EXPONENT_CHx represents the current-full scale range selected. The selected range can be automatically determined by the auto-range selection logic or manually selected as per [Table 8-3](#).

8.4.5.1 Determining ADC Codes for Each Channel

Data for each channel is given as exponent and mantissa components by the sensor. Raw ADC_CODES corresponding to the intensity measured on each channel is determined using the following equations. First the mantissa component is calculated from the MSB and LSB registers.

$$\text{MANTISSA_CHx} = (\text{RESULT_MSB_CHx} \ll 8) + \text{RESULT_LSB_CHx} \quad (1)$$

or

$$\text{MANTISSA_CHx} = (\text{RESULT_MSB_CHx} \times 2^8) + \text{RESULT_LSB_CHx} \quad (2)$$

where

- RESULT_MSB_CHx, RESULT_LSB_CHx and EXPONENT_CHx are registers part of the output register for each channel

The RESULT_MSB_CHx register carries the most significant 12 bits of the MANTISSA_CHx, and RESULT_LSB_CHx register carries the least significant eight bits of the MANTISSA_CHx. The MANTISSA_CHx is then computed using the above equations to get the 20-bit number. The EXPONENT_CHx is directly read from the register, which is four bits.

After the EXPONENT_CHx and MANTISSA_CHx portions are calculated, use the following equations to calculate the linearized ADC_CODES_CHx:

$$\text{ADC_CODES_CHx} = (\text{MANTISSA_CHx} \ll \text{EXPONENT_CHx}) \quad (3)$$

or

$$\text{ADC_CODES_CHx} = (\text{MANTISSA_CHx} \times 2^{\text{EXPONENT_CHx}}) \quad (4)$$

The maximum value for register EXPONENT_CHx is 6, therefore ADC_CODES is effectively a 26-bit number. The semi-logarithmic numbers have been converted to a linear ADC_CODES_CHx representation making simple to convert to lux and RGB color coordinates.

8.4.5.2 Lux and Color Calculations

The red (R), green (G), and blue (B) color content detected by the sensor can be calculated from the ADC_CODES of Channels 0, 1, and 2 using [Equation 5](#), [Equation 6](#), and [Equation 7](#). The R,G,B values are defined such that white (R=G=B) is read when a D65 standard white light source is shined on the sensor.

$$R = \text{ADC_CODES_CH0} \times 2.4 \quad (5)$$

$$G = \text{ADC_CODES_CH1} \times 1.0 \quad (6)$$

$$B = \text{ADC_CODES_CH2} \times 1.3 \quad (7)$$

It is typically convenient to normalize the R,G,B values to indicate color independent of light intensity. This can be done using the below equations and is represented here as R',G',B'. This allows colors to be compared independent of light intensity. [Application Curve](#) gives more details on working with normalized R',G',B' values.

$$R' = R / (R + G + B) \quad (8)$$

$$G' = G / (R + G + B) \quad (9)$$

$$B' = B / (R + G + B) \quad (10)$$

In addition to color information, the light intensity is extracted from the sensor as shown in [Equation 11](#) and represented in units of lux.

$$\text{lux} = \text{ADC_CODES_CH1} \times 2.15 \times 10^{-3} \quad (11)$$

8.4.5.3 Threshold Detection Calculations

Threshold result registers [THRESHOLD_H_RESULT](#) and [THRESHOLD_L_RESULT](#) are 12 bits, while threshold exponent registers [THRESHOLD_H_EXPONENT](#) and [THRESHOLD_L_EXPONENT](#) are four bits. The threshold is compared at linear ADC_CODES_CHx, therefore the threshold registers are padded with zeros internally as shown to compare with the ADC_CODES_CHx

$$\text{ADC_CODES_TH} = \text{THRESHOLD_H_RESULT} \ll (8 + \text{THRESHOLD_H_EXPONENT}) \quad (12)$$

or

$$\text{ADC_CODES_TH} = \text{THRESHOLD_H_RESULT} \times 2^{(8 + \text{THRESHOLD_H_EXPONENT})} \quad (13)$$

and

$$\text{ADC_CODES_TL} = \text{THRESHOLD_L_RESULT} \ll (8 + \text{THRESHOLD_L_EXPONENT}) \quad (14)$$

or

$$\text{ADC_CODES_TL} = \text{THRESHOLD_L_RESULT} \times 2^{(8 + \text{THRESHOLD_L_EXPONENT})} \quad (15)$$

Threshold are then compared as shown to detect Fault events.

$$\text{If } \text{ADC_CODES_CH}_x < \text{ADC_CODES_TL} \text{ a Fault Low is detected} \quad (16)$$

and

$$\text{If } \text{ADC_CODES_CH}_x > \text{ADC_CODES_TH} \text{ a Fault High is detected} \quad (17)$$

Based on the [FAULT_COUNT](#) register setting, with consecutive Fault High or Fault Low events, respective [FLAG_H](#) and [FLAG_L](#) registers are set. Clearly understanding the difference between [THRESHOLD_H_EXPONENT](#), [THRESHOLD_H_RESULT](#), [THRESHOLD_L_EXPONENT](#), [THRESHOLD_L_RESULT](#) and the output registers is important to be able to set appropriate threshold based on application needs. See [Interrupt Modes of Operation](#) for more information.

8.4.6 Light Resolution

The OPT4060 effective resolution is dependent on both the conversion time setting and the full-scale light range. Although the LSB resolution of the linear ADC_CODES does not change, the effective or useful resolution of the device is dependent on the conversion time setting and the full-scale range as per the table below. In conversion times where the effective resolution is lower, the LSBs are padded with 0.

Table 8-5. Resolution Table

CONVERSION TIME REGISTER	CONVERSION TIME	MANTESSA EFFECTIVE BITS	EXPONENT	0	1	2	3	4	5	6
			FULL-SCALE LUX	2254	4509	9018	18036	36071	72142	144284
EFFECTIVE RESOLUTION IN LUX										
0	600 us	9		4.4	8.8	17.6	35.2	70.45	140.9	281.8
1	1 ms	10		2.2	4.4	8.8	17.6	35.2	70.45	140.9
2	1.8 ms	11		1.1	2.2	4.4	8.8	17.6	35.2	70.45
3	3.4 ms	12		550.4 m	1.1	2.2	4.4	8.8	17.6	35.2
4	6.5 ms	13		275.2 m	550.4 m	1.1	2.2	4.4	8.8	17.6
5	12.7 ms	14		137.6 m	275.2 m	550.4 m	1.1	2.2	4.4	8.8
6	25 ms	15		68.8 m	137.6 m	275.2 m	550.4 m	1.1	2.2	4.4
7	50 ms	16		34.4 m	68.8 m	137.6 m	275.2 m	550.4 m	1.1	2.2
8	100 ms	17		17.2 m	34.4 m	68.8 m	137.6 m	275.2 m	550.4 m	1.1
9	200 ms	18		8.6 m	17.2 m	34.4 m	68.8 m	137.6 m	275.2 m	550.4 m
10	400 ms	19		4.30 m	8.6 m	17.2 m	34.4 m	68.8 m	137.6 m	275.2 m
11	800 ms	20		2.15 m	4.30 m	8.6 m	17.2 m	34.4 m	68.8 m	137.6 m

As shown in the table above, the resolution of the device is dependent on the [CONVERSION_TIME](#) and full-scale range. A similar scaling applies to the peak responsivity for each channel.

8.5 Programming

The OPT4060 supports the transmission protocol for standard mode (up to 100 kHz), fast mode (up to 400 kHz), and high-speed mode (up to 2.6 MHz). Fast and standard modes are described as the default protocol, referred to as *F/S*. High-speed mode is described in [High-Speed I²C Mode](#).

8.5.1 I²C Bus Overview

The OPT4060 offers compatibility with both I²C and SMBus interfaces. The I²C and SMBus protocols are essentially compatible with one another. The I²C interface is used throughout this document as the primary example with the SMBus protocol specified only when a difference between the two protocols is discussed.

The device is connected to the bus with two pins: an SCL clock input pin and an SDA open-drain bidirectional data pin. The bus must have a controller device that generates the serial clock (SCL), controls the bus access,

and generates start and stop conditions. To address a specific device, the controller initiates a start condition by pulling the data signal line (SDA) from a high logic level to a low logic level while SCL is high. All targets on the bus shift in the target address byte on the SCL rising edge, with the last bit indicating whether a read or write operation is intended. During the ninth clock pulse, the addressed target generates an acknowledge bit by pulling SDA low to respond to the controller.

Data transfer is then initiated and eight bits of data are sent, followed by an acknowledge bit. During data transfer, SDA must remain stable while SCL is high. Any change in SDA while SCL is high is interpreted as a start or stop condition. When all data are transferred, the controller generates a stop condition, indicated by pulling SDA from low to high while SCL is high. The device includes a 28-ms timeout on the I²C interface to prevent locking up the bus. If the SCL line is held low for this duration of time, the bus state machine is reset.

8.5.1.1 Serial Bus Address

To communicate with the OPT4060, the controller must first initiate an I²C start command. Then, the controller must address target devices through a target address byte. The target address byte consists of a 7-bit address and a direction bit that indicates whether the action is to be a read or write operation.

Four I²C addresses are possible by connecting the ADDR pin to one of four pins: GND, VDD, SDA, or SCL. [Table 8-6](#) summarizes the possible addresses with the corresponding ADDR pin configuration. The state of the ADDR pin is sampled on every bus communication and must be driven or connected to the desired level before any activity on the interface occurs.

Table 8-6. ADDR Pin Configuration

ADDR PIN CONNECTION	DEVICE I ² C ADDRESS
GND	1000100
VDD	1000101
SDA	1000110
SCL	1000111

8.5.1.2 Serial Interface

The OPT4060 operates as a target device on both the I²C bus and SMBus. Connections to the bus are made through the SCL clock input line and the SDA open-drain I/O line. The device supports the transmission protocol for standard mode (up to 100 kHz), fast mode (up to 400 kHz), and high-speed mode (up to 2.6 MHz). All data bytes are transmitted by most significant bits first.

The SDA and SCL pins feature integrated spike-suppression filters and Schmitt triggers to minimize the effects of input spikes and bus noise. See the [Electrical Interface](#) section for more information on I²C bus noise immunity.

8.5.2 Writing and Reading

Accessing a specific register on the OPT4060 is accomplished by writing the appropriate register address during the I²C transaction sequence. Refer to the [Register Maps](#) for a complete list of registers and their corresponding register addresses. The value for the register address (as shown in [Register Maps](#)) is the first byte transferred after the target address byte with the R/W bit low.

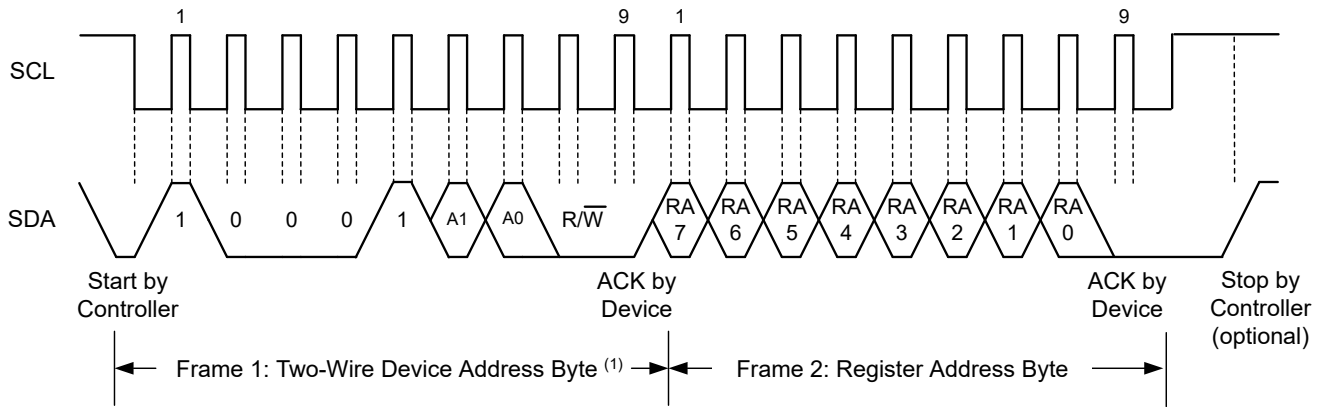

Figure 8-3. Setting the I²C Register Address

Writing to a register begins with the first byte transmitted by the controller. This byte is the target address with the R/W bit low. The device then acknowledges receipt of a valid address. The register address the data will write to is the next byte transmitted by the controller. The next two bytes are written to the register addressed by the register address. The device acknowledges receipt of each data byte. The controller can terminate the data transfer by generating a start or stop condition.

When reading from the device, the last value stored in the register address by a write operation determines which register is read during a read operation. To change the register address for a read operation, a new partial I²C write transaction must be initiated. This partial write is accomplished by issuing a target address byte with the R/W bit low, followed by the register address byte and a stop command. The controller then generates a start condition and sends the target address byte with the R/W bit high to initiate the read command. The next byte is transmitted by the target and is the most significant byte of the register indicated by the register address. This byte is followed by an acknowledge from the controller; then the target transmits the least significant byte. The controller acknowledges receipt of the data byte. The controller can terminate the data transfer by generating a not-acknowledge after receiving any data byte, or by generating a start or stop condition. If repeated reads from the same register are desired, continually sending the register address bytes is not necessary; the device retains the register address until that number is changed by the next write operation.

Figure 8-4 and Figure 8-5 show the write and read operation timing diagrams, respectively. Note that register bytes are sent most significant byte first, followed by the least significant byte.

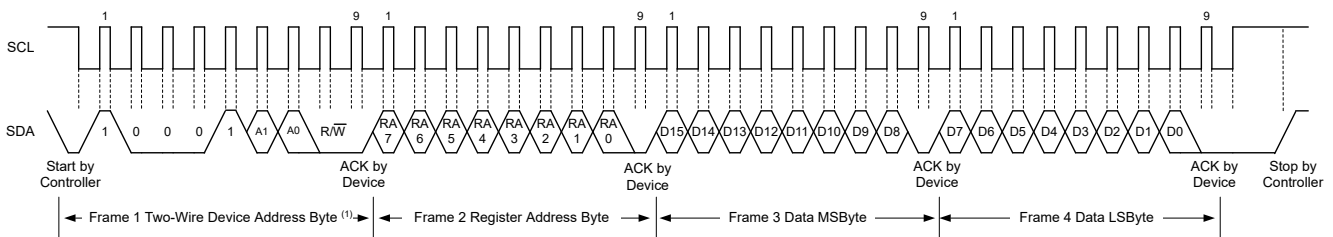
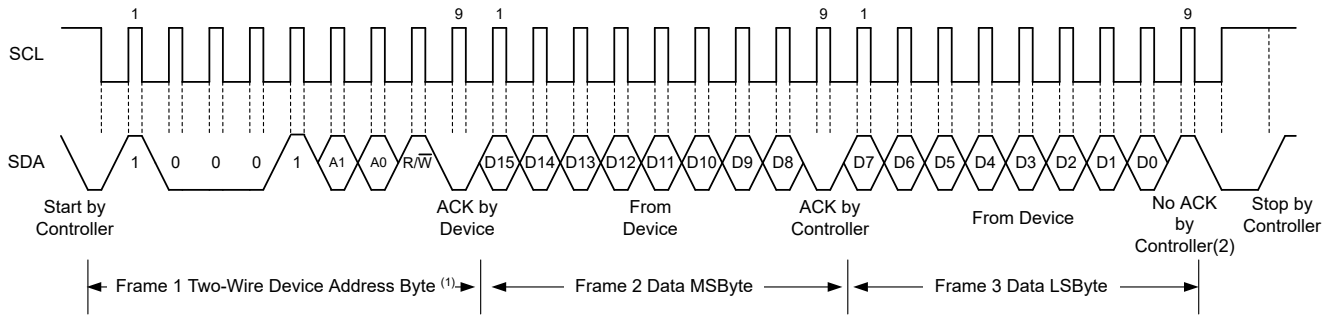

Figure 8-4. I²C Write Example



A. An ACK by the controller can also be sent.

Figure 8-5. I²C Read Example

8.5.2.1 High-Speed I²C Mode

When the bus is idle, both the SDA and SCL lines are pulled high by the pullup resistors or active pullup devices. The controller generates a start condition followed by a valid serial byte containing the high-speed (HS) controller code 0000 1XXXb. This transmission is made in either standard mode or fast mode (up to 400 kHz). The device does not acknowledge the HS controller code but does recognize the code and switches the internal filters to support a 2.6-MHz operation.

The controller then generates a repeated start condition (a repeated start condition has the same timing as the start condition). After this repeated start condition, the protocol is the same as F/S mode, except that transmission speeds up to 2.6 MHz are allowed. Instead of using a stop condition, use repeated start conditions to secure the bus in HS mode. A stop condition ends the HS mode and switches all internal filters of the device to support the F/S mode.

8.5.2.2 Burst Read Mode

The OPT4060 supports I²C burst read mode which helps in minimizing the number of transactions on the bus for efficient data transfer from the device to the controller.

Before considering the burst mode, a regular I²C read transaction involves an I²C write operation to the device read pointer, followed by the actual I²C read operation. With the output registers in continuous locations, writing the register pointer every two bytes takes up several clock cycles. With the burst mode enabled, the read pointer address is auto incremented after every register read (two bytes), eliminating the need write operations to set the pointer for subsequent register reads.

Burst mode can be enabled by setting the register [I2C_BURST](#). When a STOP command is issued the pointer resets to the original register address before the auto-increments.

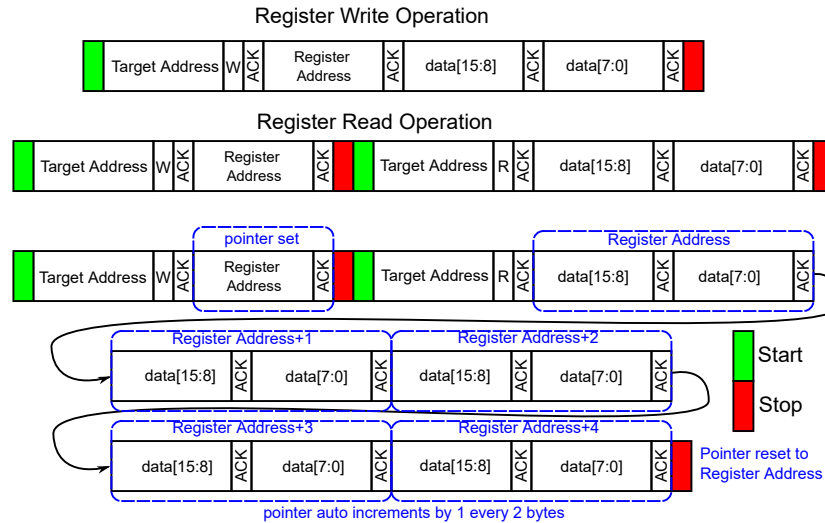

Figure 8-6. I²C Operations

8.5.2.3 General-Call Reset Command

The I²C general-call reset allows the host controller in one command to reset all devices on the bus that respond to the general-call reset command. The general call is initiated by writing to the I²C address 0 (0000 0000b). The reset command is initiated when the subsequent second address byte is 06h (0000 0110b). With this transaction, the device issues an acknowledge bit and sets all registers to the power-on-reset default condition.

8.5.2.4 SMBus Alert Response

The SMBus alert response provides a quick identification for which device issued the interrupt. Without this alert response capability, the processor does not know which device pulled the interrupt line when there are multiple target devices connected.

The OPT4060 is designed to respond to the SMBus alert response address, when in the latched window-style comparison mode. The OPT4060 does not respond to the SMBus alert response when in transparent mode.

Figure 8-7 shows the OPT4060 device behavior to the SMBus alert response. When the interrupt line to the processor is pulled to active, the controller can broadcast the alert response target address. Following this alert response, any target devices that generated an alert identify themselves by acknowledging the alert response and sending respective I²C address on the bus. The alert response can activate several different target devices simultaneously. If more than one target attempts to respond, bus arbitration rules apply. The device with the lowest address wins the arbitration. If the OPT4060 loses the arbitration, the device does not acknowledge the I²C transaction and the INT pin remains in an active state, prompting the I²C controller processor to issue a subsequent SMBus alert response. When the OPT4060 wins the arbitration, the device acknowledges the transaction and sets the INT pin to inactive. The controller can issue that same command again, as many times as necessary to clear the INT pin. See [Interrupt Modes of Operation](#) for additional details of how the flags and INT pin are controlled. The controller can obtain information about the source of the OPT4060 interrupt from the address broadcast in the above process. The `FLAG_H` value is sent as the final LSB of the address to provide the controller additional information about the cause of the OPT4060 interrupt. If the controller requires additional information, the result register or the configuration register can be queried. The `FLAG_H` and `FLAG_L` registers are not cleared upon an SMBus alert response.

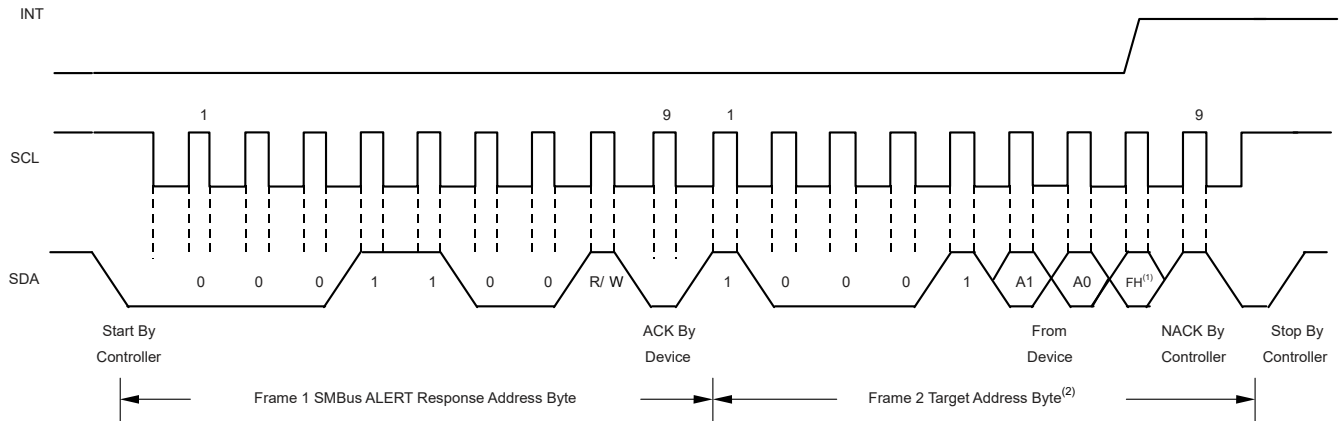

- A. FH is the [FLAG_H](#) register
- B. A1 and A0 are determined by the ADDR pin

Figure 8-7. Timing Diagram for SMBus Alert Response

8.6 Register Maps

Figure 8-8. ALL Register Map

ADD	D15	D14	D13	D12	D11	D10	D9	D8	D7	D6	D5	D4	D3	D2	D1	D0	
00h	EXPONENT_CH0					RESULT_MSB_CH0											
01h	RESULT_LSB_CH0					COUNTER_CH0					CRC_CH0						
02h	EXPONENT_CH1					RESULT_MSB_CH1											
03h	RESULT_LSB_CH1					COUNTER_CH1					CRC_CH1						
04h	EXPONENT_CH2					RESULT_MSB_CH2											
05h	RESULT_LSB_CH2					COUNTER_CH2					CRC_CH2						
06h	EXPONENT_CH3					RESULT_MSB_CH3											
07h	RESULT_LSB_CH3					COUNTER_CH3					CRC_CH3						
08h	THRESHOLD_L_EXPONENT					THRESHOLD_L_RESULT											
09h	THRESHOLD_H_EXPONENT					THRESHOLD_H_RESULT											
0Ah	QWAKE	0	RANGE				CONVERSION_TIME				OPERATING_MODE		LATCH	INT_POL	FAULT_COUNT		
0Bh	128					THRESHOLD_CH_SEL				INT_DIR	INT_CFG			0	I2C_BURST		
0Ch	0											OVERLOAD_FLAG	CONVERSION_READY_FLAG	FLAG_H	FLAG_L		
11h	0		DIDL			DIDH											

8.6.1 Register Map

8.6.1.1 Register 0h (offset = 0h) [reset = 0h]

Figure 8-9. Register 0h

15	14	13	12	11	10	9	8
EXPONENT_CH0				RESULT_MSB_CH0			
R-0h				R-0h			
7	6	5	4	3	2	1	0
RESULT_MSB_CH0							
R-0h							

LEGEND: R/W = Read/Write; W = Write only; -n = value after reset

Figure 8-10. Register 00 Field Descriptions

Bit	Field	Type	Reset	Description
15-12	EXPONENT_CH0	R	0h	EXPONENT output CH0. Determines the full-scale range of the light measurement for the channel.
11-0	RESULT_MSB_CH0	R	0h	Result register MSB (Most significant bits) CH0. Used to calculate the MANTISSA representing light level within a given EXPONENT or full-scale range

8.6.1.2 Register 1h (offset = 1h) [reset = 0h]

Figure 8-11. Register 1h

15	14	13	12	11	10	9	8
RESULT_LSB_CH0							
R-0h							
7	6	5	4	3	2	1	0
COUNTER_CH0				CRC_CH0			
R-0h				R-0h			

LEGEND: R/W = Read/Write; W = Write only; -n = value after reset

Figure 8-12. Register 01 Field Descriptions

Bit	Field	Type	Reset	Description
15-8	RESULT_LSB_CH0	R	0h	Result register LSB(Least significant bits) CH0. Used to calculate MANTISSA representing light level within a given EXPONENT or full-scale range
7-4	COUNTER_CH0	R	0h	Sample counter CH0. Rolling counter which increments for every conversion
3-0	CRC_CH0	R	0h	CRC bits CH0. $R[19:0] = (\text{RESULT_MSB_CH0}[11:0] \ll 8) + \text{RESULT_LSB_CH0}[7:0]$ $X[0] = \text{XOR}(\text{EXPONENT_CH0}[3:0], R[19:0], \text{CRC_CH0}[3:0])$ XOR of all bits $X[1] = \text{XOR}(\text{CRC_CH0}[1], \text{CRC_CH0}[3], R[1], R[3], R[5], R[7], R[9], R[11], R[13], R[15], R[17], R[19], E[1], E[3])$ $X[2] = \text{XOR}(\text{CRC_CH0}[3], R[3], R[7], R[11], R[15], R[19], E[3])$ $X[3] = \text{XOR}(R[3], R[11], R[19])$

8.6.1.3 Register 2h (offset = 2h) [reset = 0h]

Figure 8-13. Register 2h

15	14	13	12	11	10	9	8
EXPONENT_CH1				RESULT_MSB_CH1			
R-0h				R-0h			
7	6	5	4	3	2	1	0
RESULT_MSB_CH1							
R-0h							

LEGEND: R/W = Read/Write; W = Write only; -n = value after reset

Figure 8-14. Register 02 Field Descriptions

Bit	Field	Type	Reset	Description
15-12	EXPONENT_CH1	R	0h	EXPONENT output CH1. Determines the full-scale range of the light measurement for the channel.
11-0	RESULT_MSB_CH1	R	0h	Result register MSB (Most significant bits) CH1. Used to calculate the MANTISSA representing light level within a given EXPONENT or full-scale range

8.6.1.4 Register 3h (offset = 3h) [reset = 0h]

Figure 8-15. Register 3h

15	14	13	12	11	10	9	8
RESULT_LSB_CH1							
R-0h							
7	6	5	4	3	2	1	0
COUNTER_CH1				CRC_CH1			
R-0h				R-0h			

LEGEND: R/W = Read/Write; W = Write only; -n = value after reset

Figure 8-16. Register 03 Field Descriptions

Bit	Field	Type	Reset	Description
15-8	RESULT_LSB_CH1	R	0h	Result register LSB(Least significant bits) CH1. Used to calculate MANTISSA representing light level within a given EXPONENT or full-scale range
7-4	COUNTER_CH1	R	0h	Sample counter CH1. Rolling counter which increments for every conversion
3-0	CRC_CH1	R	0h	CRC bits CH1. $R[19:0] = (\text{RESULT_MSB_CH1}[11:0] \ll 8) + \text{RESULT_LSB_CH1}[7:0]$ $X[0] = \text{XOR}(\text{EXPONENT_CH1}[3:0], R[19:0], \text{CRC_CH1}[3:0])$ XOR of all bits $X[1] = \text{XOR}(\text{CRC_CH1}[1], \text{CRC_CH1}[3], R[1], R[3], R[5], R[7], R[9], R[11], R[13], R[15], R[17], R[19], E[1], E[3])$ $X[2] = \text{XOR}(\text{CRC_CH1}[3], R[3], R[7], R[11], R[15], R[19], E[3])$ $X[3] = \text{XOR}(R[3], R[11], R[19])$

8.6.1.5 Register 4h (offset = 4h) [reset = 0h]

Figure 8-17. Register 4h

15	14	13	12	11	10	9	8
EXPONENT_CH2				RESULT_MSB_CH2			
R-0h				R-0h			
7	6	5	4	3	2	1	0
RESULT_MSB_CH2							
R-0h							

LEGEND: R/W = Read/Write; W = Write only; -n = value after reset

Figure 8-18. Register 04 Field Descriptions

Bit	Field	Type	Reset	Description
15-12	EXPONENT_CH2	R	0h	EXPONENT output CH2. Determines the full-scale range of the light measurement for the channel.
11-0	RESULT_MSB_CH2	R	0h	Result register MSB (Most significant bits) CH2. Used to calculate the MANTISSA representing light level within a given EXPONENT or full-scale range

8.6.1.6 Register 5h (offset = 5h) [reset = 0h]

Figure 8-19. Register 5h

15	14	13	12	11	10	9	8
RESULT_LSB_CH2							
R-0h							
7	6	5	4	3	2	1	0
COUNTER_CH2				CRC_CH2			
R-0h				R-0h			

LEGEND: R/W = Read/Write; W = Write only; -n = value after reset

Figure 8-20. Register 05 Field Descriptions

Bit	Field	Type	Reset	Description
15-8	RESULT_LSB_CH2	R	0h	Result register LSB(Least significant bits) CH2. Used to calculate MANTISSA representing light level within a given EXPONENT or full-scale range
7-4	COUNTER_CH2	R	0h	Sample counter CH2. Rolling counter which increments for every conversion
3-0	CRC_CH2	R	0h	CRC bits CH2. $R[19:0] = (RESULT_MSB_CH2[11:0] \ll 8) + RESULT_LSB_CH2[7:0]$ $X[0] = XOR(EXPONENT_CH2[3:0], R[19:0], CRC_CH2[3:0])$ XOR of all bits $X[1] = XOR(CRC_CH2[1], CRC_CH2[3], R[1], R[3], R[5], R[7], R[9], R[11], R[13], R[15], R[17], R[19], E[1], E[3])$ $X[2] = XOR(CRC_CH2[3], R[3], R[7], R[11], R[15], R[19], E[3])$ $X[3] = XOR(R[3], R[11], R[19])$

8.6.1.7 Register 6h (offset = 6h) [reset = 0h]

Figure 8-21. Register 6h

15	14	13	12	11	10	9	8
EXPONENT_CH3				RESULT_MSB_CH3			
R-0h				R-0h			
7	6	5	4	3	2	1	0
RESULT_MSB_CH3							
R-0h							

LEGEND: R/W = Read/Write; W = Write only; -n = value after reset

Figure 8-22. Register 06 Field Descriptions

Bit	Field	Type	Reset	Description
15-12	EXPONENT_CH3	R	0h	EXPONENT output CH3. Determines the full-scale range of the light measurement for the channel.
11-0	RESULT_MSB_CH3	R	0h	Result register MSB (Most significant bits) CH3. Used to calculate the MANTISSA representing light level within a given EXPONENT or full-scale range

8.6.1.8 Register 7h (offset = 7h) [reset = 0h]

Figure 8-23. Register 7h

15	14	13	12	11	10	9	8
RESULT_LSB_CH3							
R-0h							
7	6	5	4	3	2	1	0
COUNTER_CH3				CRC_CH3			
R-0h				R-0h			

LEGEND: R/W = Read/Write; W = Write only; -n = value after reset

Figure 8-24. Register 07 Field Descriptions

Bit	Field	Type	Reset	Description
15-8	RESULT_LSB_CH3	R	0h	Result register LSB (Least significant bits) CH3. Used to calculate MANTISSA representing light level within a given EXPONENT or full-scale range
7-4	COUNTER_CH3	R	0h	Sample counter CH3. Rolling counter which increments for every conversion
3-0	CRC_CH3	R	0h	CRC bits CH3. $R[19:0] = (\text{RESULT_MSB_CH3}[11:0] \ll 8) + \text{RESULT_LSB_CH3}[7:0]$ $X[0] = \text{XOR}(\text{EXPONENT_CH3}[3:0], R[19:0], \text{CRC_CH3}[3:0])$ XOR of all bits $X[1] = \text{XOR}(\text{CRC_CH3}[1], \text{CRC_CH3}[3], R[1], R[3], R[5], R[7], R[9], R[11], R[13], R[15], R[17], R[19], E[1], E[3])$ $X[2] = \text{XOR}(\text{CRC_CH3}[3], R[3], R[7], R[11], R[15], R[19], E[3])$ $X[3] = \text{XOR}(R[3], R[11], R[19])$

8.6.1.9 Register 8h (offset = 8h) [reset = 0h]

Figure 8-25. Register 8h

15	14	13	12	11	10	9	8
THRESHOLD_L_EXPONENT				THRESHOLD_L_RESULT			
R/W-0h				R/W-0h			
7	6	5	4	3	2	1	0
THRESHOLD_L_RESULT							
R/W-0h							

LEGEND: R/W = Read/Write; W = Write only; -n = value after reset

Figure 8-26. Register 08 Field Descriptions

Bit	Field	Type	Reset	Description
15-12	THRESHOLD_L_EXPONENT	R/W	0h	Threshold low register exponent
11-0	THRESHOLD_L_RESULT	R/W	0h	Threshold low register result

8.6.1.10 Register 9h (offset = 9h) [reset = BFFFh]

Figure 8-27. Register 9h

15	14	13	12	11	10	9	8
THRESHOLD_H_EXPONENT				THRESHOLD_H_RESULT			
R/W-Bh				R/W-Fh			
7	6	5	4	3	2	1	0
THRESHOLD_H_RESULT							
R/W-FFh							

LEGEND: R/W = Read/Write; W = Write only; -n = value after reset

Figure 8-28. Register 09 Field Descriptions

Bit	Field	Type	Reset	Description
15-12	THRESHOLD_H_EXPONENT	R/W	Bh	Threshold high register exponent
11-0	THRESHOLD_H_RESULT	R/W	FFFh	Threshold high register result

8.6.1.11 Register Ah (offset = Ah) [reset = 3208h]

Figure 8-29. Register Ah

15	14	13	12	11	10	9	8
QWAKE	0	RANGE				CONVERSION_TIME	
R/W-0h	W-0h	R/W-Ch				R/W-2h	
7	6	5	4	3	2	1	0
CONVERSION_TIME		OPERATING_MODE		LATCH	INT_POL	FAULT_COUNT	
R/W-0h		R/W-0h		R/W-1h	R/W-0h	R/W-0h	

LEGEND: R/W = Read/Write; W = Write only; -n = value after reset

Figure 8-30. Register 0A Field Descriptions

Bit	Field	Type	Reset	Description
15-15	QWAKE	R/W	0h	Quick Wake-up from Standby in one shot mode by not powering down all circuits. Applicable only in one shot mode and helps get out of standby mode faster with penalty in power consumption compared to full standby mode.
14-14	0	W	0h	Must read or write 0
13-10	RANGE	R/W	Ch	Controls the full-scale light level range of the device. The format of this register is same as the EXPONENT register for all values from 0 to 6. 0 : 2.2klux 1 : 4.5kux 2 : 9klux 3 : 18klux 4 : 36klux 5 : 72klux 6 : 144klux 12 : Auto-Range
9-6	CONVERSION_TIME	R/W	8h	Controls the device conversion time per channel 0 : 600 us 1 : 1 ms 2 : 1.8 ms 3 : 3.4 ms 4 : 6.5 ms 5 : 12.7 ms 6 : 25 ms 7 : 50 ms 8 : 100 ms 9 : 200 ms 10 : 400 ms 11 : 800 ms
5-4	OPERATING_MODE	R/W	0h	Controls device mode of operation 0 : Power-down 1 : Forced auto-range OneShot 2 : OneShot 3 : Continuous
3-3	LATCH	R/W	1h	Controls the functionality of the interrupt reporting mechanisms for INT pin for the threshold detection logic.
2-2	INT_POL	R/W	0h	Controls the polarity or active state of the INT pin. 0 : Active Low 1 : Active High

Figure 8-30. Register 0A Field Descriptions (continued)

Bit	Field	Type	Reset	Description
1-0	FAULT_COUNT	R/W	0h	Fault count register instructs the device as to how many consecutive fault events are required to trigger the threshold mechanisms: the flag high (FLAG_H) and the flag low (FLAG_L) registers. 0 : One fault Count 1 : Two Fault Counts 2 : Four Fault Counts 3 : Eight Fault Counts

8.6.1.12 Register Bh (offset = Bh) [reset = 8011h]

Figure 8-31. Register Bh

15	14	13	12	11	10	9	8
1	0	0	0	0	0	0	0
R/W-1h	R/W-0h	W-0h	W-0h	W-0h	R/W-0h	R/W-0h	R/W-0h
7	6	5	4	3	2	1	0
0	THRESHOLD_CH_SEL		INT_DIR	INT_CFG		0	I2C_BURST
R/W-0h	R/W-0h		R/W-1h	R/W-0h		R/W-0h	R/W-1h

LEGEND: R/W = Read/Write; W = Write only; -n = value after reset

Figure 8-32. Register 0B Field Descriptions

Bit	Field	Type	Reset	Description
15-7	128	R/W	80h	Must read or write 128
6-5	THRESHOLD_CH_SEL	R/W	0h	Channel select for threshold logic 0 : CH0 Selected 1 : CH1 Selected 2 : CH2 Selected 3 : CH3 Selected
4-4	INT_DIR	R/W	1h	Determines the direction of the INT pin. 0 : Input 1 : Output
3-2	INT_CFG	R/W	0h	Controls the output interrupt mechanism after end of conversion 0 : SMBUS Alert 1 : INT Pin data ready for next channel 3 : INT Pin data ready for all channels
1-1	0	R/W	0h	Must read or write 0
0-0	I2C_BURST	R/W	1h	When set enables I2C burst mode minimizing I2C read cycles by auto incrementing read register point by 1 after every register read

8.6.1.13 Register Ch (offset = Ch) [reset = 0h]

Figure 8-33. Register Ch

15	14	13	12	11	10	9	8
0	0	0	0	0	0	0	0
R/W-0h	R/W-0h	R/W-0h	R/W-0h	R/W-0h	R/W-0h	R/W-0h	R/W-0h
7	6	5	4	3	2	1	0
0	0	0	0	OVERLOAD_F LAG	CONVERSION _READY_FLAG	FLAG_H	FLAG_L
R/W-0h	R/W-0h	R/W-0h	R/W-0h	R-0h	R-0h	R-0h	R-0h

LEGEND: R/W = Read/Write; W = Write only; -n = value after reset

Figure 8-34. Register 0C Field Descriptions

Bit	Field	Type	Reset	Description
15-4	0	R/W	0h	Must read or write 0
3-3	OVERLOAD_FL AG	R	0h	Indicates when an overflow condition occurs in the data conversion process, typically because the light illuminating the device exceeds the full-scale range.
2-2	CONVERSION_R EADY_FLAG	R	0h	Conversion ready flag indicates when a conversion completes. The flag is set to 1 at the end of a conversion and is cleared (set to 0) when register address 0xA is either read or written with any non-zero value 0 : Conversion in progress 1 : Conversion is complete
1-1	FLAG_H	R	0h	Flag high register identifies that the result of a conversion is measurement than a specified level of interest. FLAG_H is set to 1 when the result is larger than the level in the THRESHOLD_H_EXPONENT and THRESHOLD_H_RESULT registers for a consecutive number of measurements defined by the FAULT_COUNT register.
0-0	FLAG_L	R	0h	Flag low register identifies that the result of a measurement is smaller than a specified level of interest. FLAG_L is set to 1 when the result is smaller than the level in the THRESHOLD_L_EXPONENT and THRESHOLD_L_RESULT registers for a consecutive number of measurements defined by the FAULT_COUNT register.

8.6.1.14 Register 11h (offset = 11h) [reset = 820h]

Figure 8-35. Register 11h

15	14	13	12	11	10	9	8
0	0	DIDL		DIDH			
R/W-0h	R/W-0h	R-0h		R-8h			
7	6	5	4	3	2	1	0
DIDH							
R-21h							

LEGEND: R/W = Read/Write; W = Write only; -n = value after reset

Figure 8-36. Register 11 Field Descriptions

Bit	Field	Type	Reset	Description
15-14	0	R/W	0h	Must read or write 0
13-12	DIDL	R	8h	Device ID L
11-0	DIDH	R	21h	Device ID H

9 Application and Implementation

Note

Information in the following applications sections is not part of the TI component specification, and TI does not warrant its accuracy or completeness. TI's customers are responsible for determining suitability of components for their purposes, as well as validating and testing their design implementation to confirm system functionality.

9.1 Application Information

Color sensors are used in a wide variety of applications that require precise measurement of light. The following sections show crucial information about integrating OPT4060 in applications.

There are two categories of interface to the OPT4060: electrical and optical.

9.2 Typical Application

9.2.1 Electrical Interface

The electrical interface is quite simple, as illustrated in [Figure 9-1](#) below. Connect the OPT4060 I²C SDA and SCL pins to the same pins of an applications processor, micro controller, or other digital processor. If that digital processor requires an interrupt resulting from an event of interest from the OPT4060, then connect the INT pin to either an interrupt or general-purpose I/O pin of the processor. There are multiple uses for this INT pin, including triggering a measurement on one shot mode, signaling the system to wake up from low-power mode, processing other tasks while waiting for an ambient light event of interest, or alerting the processor that a sample is ready to be read. Connect pullup resistors between a power supply appropriate for digital communication and the SDA and SCL pins (because the pins have open-drain output structures). If the INT pin is used, connect a pullup resistor to the INT pin. A typical value for these pullup resistors is 10 k Ω . The resistor choice can be optimized in conjunction to the bus capacitance to balance the system speed, power, noise immunity, and other requirements.

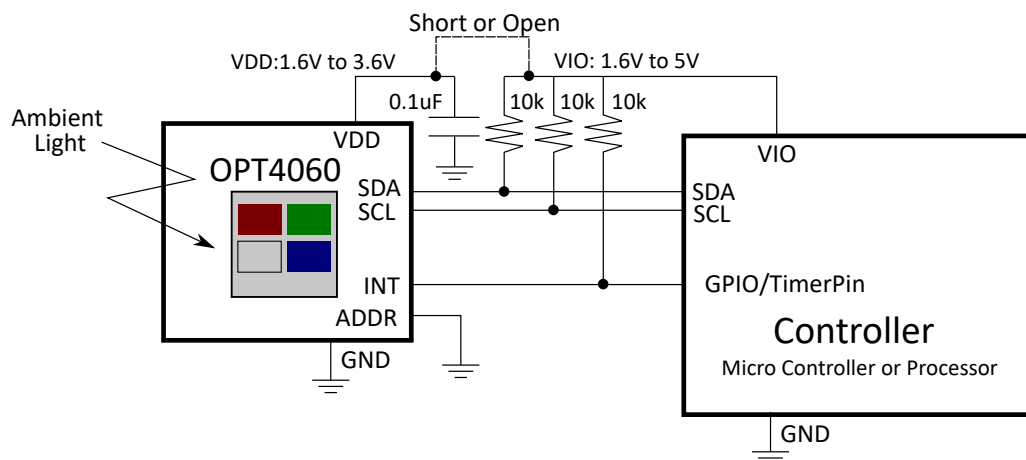

Figure 9-1. Typical Application Schematic

The power supply and grounding considerations are discussed in the [Power Supply Recommendations](#).

Although spike suppression is integrated in the SDA and SCL pin circuits, use proper layout practices to minimize the amount of coupling into the communication lines. One possible introduction of noise occurs from capacitively coupling signal edges between the two communication lines themselves. Another possible noise introduction comes from other switching noise sources present in the system, especially for long communication lines. In noisy environments, shield communication lines to reduce the possibility of unintended noise coupling into the digital I/O lines that can be incorrectly interpreted.

9.2.1.1 Design Requirements

9.2.1.1.1 Optical Interface

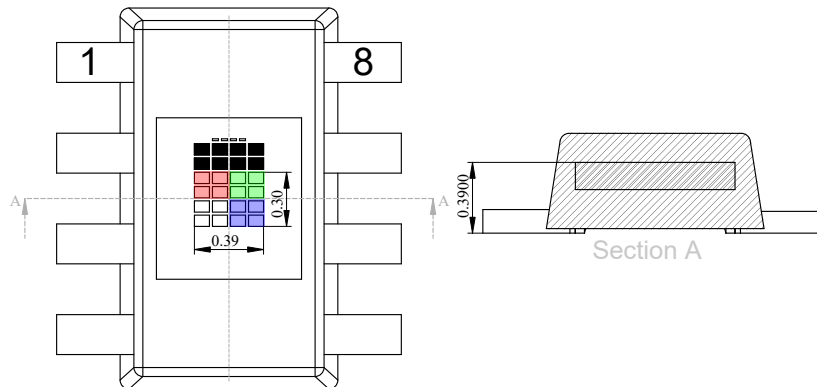

Figure 9-2. Sensor Position

Any physical component that affects the light which illuminates the sensing area of a light sensor also affects the performance of that light sensor. Therefore, for the best performance, make sure to understand and control the effect of these components. Design a window width and height to permit light from a sufficient field of view to illuminate the sensor. For best performance, use a field of view of at least $\pm 35^\circ$, or preferably $\pm 45^\circ$ or more. Understanding and designing the field of view is discussed further in the [OPT3001: Ambient Light Sensor Application Guide](#).

9.2.1.2 Detailed Design Procedure

9.2.1.2.1 Optomechanical Design

After completing the electrical design, the next task is the optomechanical design. Window sizing and placement is discussed in more rigorous detail in [OPT3001: Ambient Light Sensor Application Guide](#).

9.2.1.3 Application Curve

The scaled output from the OPT4060 channels 0, 1, and 2 correspond respectively to the red, green, and blue color content of the light incident on the device sensor area as specified in [Light and Color Measurement](#). Here is an example of such measurements performed with an RGB LED source [TI LP5036EVM](#). The intensity of the red, green and blue LEDs were varied independently and the corresponding color coordinates detected by OPT4060 measured. Normalized R',G',B' values (see [Light and Color Measurement](#)) are calculated for both the [TI LP5036EVM](#) and the OPT4060. This data can be visualized in a 3D plot as shown in [Figure 9-3](#) with the axes representing the R', G', and B' values. The normalized points form a 2D triangle with each vertex corresponding to the respective normalized red, green, and blue outputs of the LED source. The position of each point in the plot is determined by the LED light source values. The color of each point is determined by the OPT4060 R',G',B' reading. It can be seen in the plot that OPT4060 can be used to determine the color for each output setting of the light source.

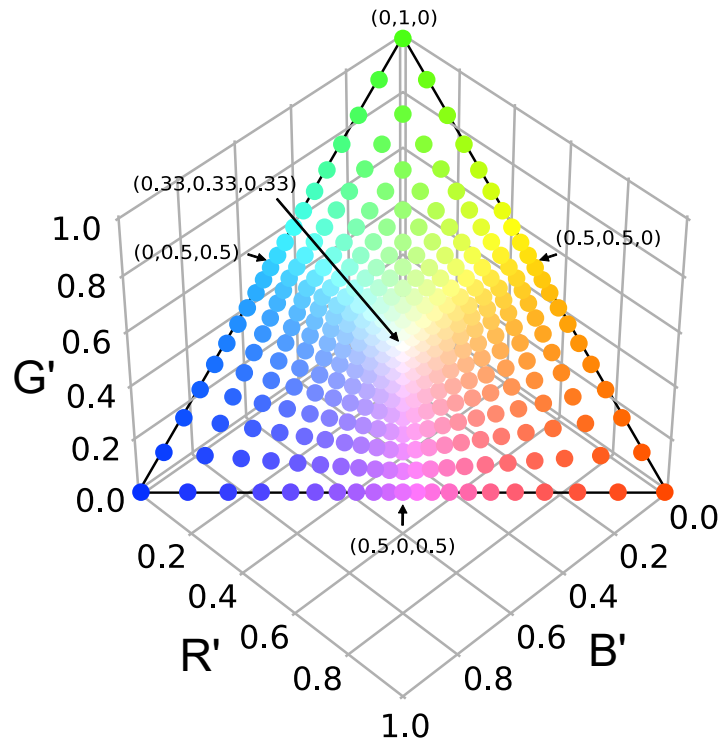

Figure 9-3. RGB Color Plot

9.3 Best Design Practices

As with any optical product, take special care when handling the OPT4060. The device is a piece of active silicon, without the mechanical protection of an epoxy-like package or other reinforcement. This design allows the device to be as thin as possible. Take extra care to handle the device gently to not crack or break the device. Use a properly-sized vacuum manipulation tool to handle the device.

The optical surface of the device must be kept clean for best performance, both when prototyping with the device, and during mass production manufacturing procedures. Keep the optical surface clean of fingerprints, dust, and other optical-inhibiting contaminants.

If the optical surface of the device requires cleaning, use a few gentle brushes with a soft swab of deionized water or isopropyl alcohol. Avoid potentially abrasive cleaning and manipulating tools and excessive force that can scratch the optical surface.

If the OPT4060 performs less than optimally, then inspect the optical surface for dirt, scratches, or other optical artifacts.

9.4 Power Supply Recommendations

Although the OPT4060 has low sensitivity to power-supply noise, good practices are always recommended. For best performance, the OPT4060 VDD pin must have a stable, low-noise power supply with a 100-nF bypass capacitor close to the device and solid grounding. There are many options for powering the OPT4060 because of the device low current consumption levels.

9.5 Layout

9.5.1 Layout Guidelines

The PCB layout design for the OPT4060 requires a couple of considerations. Bypass the power supply with a capacitor placed close to the device. Note that optically reflective surfaces of components also affect the performance of the design. Make sure to consider the three-dimensional geometry of all components and structures around the sensor to prevent unexpected results from secondary optical reflections. Placing capacitors and components at a distance of at least twice the height of the component is usually sufficient. The best optical layout is to place all close components on the opposite side of the PCB from the device. However, this approach is not practical for the constraints of every design.

An example PCB layout with the OPT4060 is shown in [Figure 9-4](#).

9.5.2 Layout Example

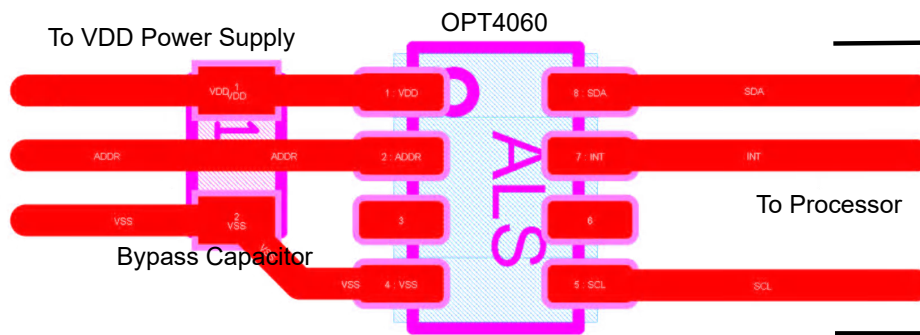
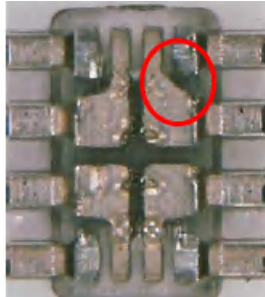

Figure 9-4. Example PCB Layout with the OPT4060 SOT-5X3 (8) Package

9.5.3 Soldering and Handling Recommendations

Soldering temperature profile and guidelines are published in future revisions of this document.

As with most optical devices, handle the OPT4060 with special care to ensure optical surfaces stay clean and free from damage. See [Best Design Practices](#) for more detailed recommendations. For best optical performance, solder flux and any other possible debris must be cleaned after soldering processes.



Note

The bottom side of the device features an angled feature to denote the PIN 1

Figure 9-5. Identification Feature for PIN 1

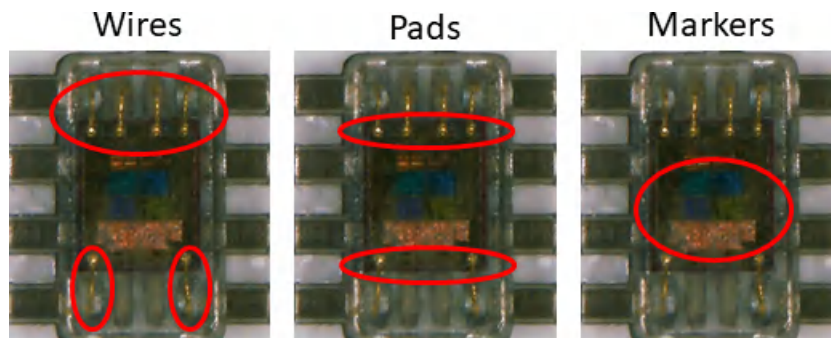

Figure 9-6. Identification Features for PIN 1 on Package

10 Device and Documentation Support

10.1 Documentation Support

10.1.1 Related Documentation

- Texas Instruments, [User's Guide for Light Sensor EVMs](#)
- Texas Instruments, [OPT3001: Ambient Light Sensor Application Guide](#)

10.2 Receiving Notification of Documentation Updates

To receive notification of documentation updates, navigate to the device product folder on [ti.com](https://www.ti.com). Click on *Notifications* to register and receive a weekly digest of any product information that has changed. For change details, review the revision history included in any revised document.

10.3 Support Resources

[TI E2E™ support forums](#) are an engineer's go-to source for fast, verified answers and design help — straight from the experts. Search existing answers or ask your own question to get the quick design help you need.

Linked content is provided "AS IS" by the respective contributors. They do not constitute TI specifications and do not necessarily reflect TI's views; see TI's [Terms of Use](#).

10.4 Trademarks

TI E2E™ is a trademark of Texas Instruments.

All trademarks are the property of their respective owners.

10.5 Electrostatic Discharge Caution



This integrated circuit can be damaged by ESD. Texas Instruments recommends that all integrated circuits be handled with appropriate precautions. Failure to observe proper handling and installation procedures can cause damage.

ESD damage can range from subtle performance degradation to complete device failure. Precision integrated circuits may be more susceptible to damage because very small parametric changes could cause the device not to meet its published specifications.

10.6 Glossary

[TI Glossary](#) This glossary lists and explains terms, acronyms, and definitions.

11 Mechanical, Packaging, and Orderable Information

The following pages include mechanical, packaging, and orderable information. This information is the most current data available for the designated devices. This data is subject to change without notice and revision of this document. For browser-based versions of this data sheet, refer to the left-hand navigation.

PACKAGING INFORMATION

Orderable part number	Status (1)	Material type (2)	Package Pins	Package qty Carrier	RoHS (3)	Lead finish/ Ball material (4)	MSL rating/ Peak reflow (5)	Op temp (°C)	Part marking (6)
OPT4060DTSR	Active	Production	SOT-5X3 (DTS) 8	3000 LARGE T&R	Yes	NIPDAU	Level-2-260C-1 YEAR	-40 to 85	4060
OPT4060DTSR.A	Active	Production	SOT-5X3 (DTS) 8	3000 LARGE T&R	Yes	NIPDAU	Level-2-260C-1 YEAR	-40 to 85	4060

(1) **Status:** For more details on status, see our [product life cycle](#).

(2) **Material type:** When designated, preproduction parts are prototypes/experimental devices, and are not yet approved or released for full production. Testing and final process, including without limitation quality assurance, reliability performance testing, and/or process qualification, may not yet be complete, and this item is subject to further changes or possible discontinuation. If available for ordering, purchases will be subject to an additional waiver at checkout, and are intended for early internal evaluation purposes only. These items are sold without warranties of any kind.

(3) **RoHS values:** Yes, No, RoHS Exempt. See the [TI RoHS Statement](#) for additional information and value definition.

(4) **Lead finish/Ball material:** Parts may have multiple material finish options. Finish options are separated by a vertical ruled line. Lead finish/Ball material values may wrap to two lines if the finish value exceeds the maximum column width.

(5) **MSL rating/Peak reflow:** The moisture sensitivity level ratings and peak solder (reflow) temperatures. In the event that a part has multiple moisture sensitivity ratings, only the lowest level per JEDEC standards is shown. Refer to the shipping label for the actual reflow temperature that will be used to mount the part to the printed circuit board.

(6) **Part marking:** There may be an additional marking, which relates to the logo, the lot trace code information, or the environmental category of the part.

Multiple part markings will be inside parentheses. Only one part marking contained in parentheses and separated by a "~" will appear on a part. If a line is indented then it is a continuation of the previous line and the two combined represent the entire part marking for that device.

Important Information and Disclaimer:The information provided on this page represents TI's knowledge and belief as of the date that it is provided. TI bases its knowledge and belief on information provided by third parties, and makes no representation or warranty as to the accuracy of such information. Efforts are underway to better integrate information from third parties. TI has taken and continues to take reasonable steps to provide representative and accurate information but may not have conducted destructive testing or chemical analysis on incoming materials and chemicals. TI and TI suppliers consider certain information to be proprietary, and thus CAS numbers and other limited information may not be available for release.

In no event shall TI's liability arising out of such information exceed the total purchase price of the TI part(s) at issue in this document sold by TI to Customer on an annual basis.

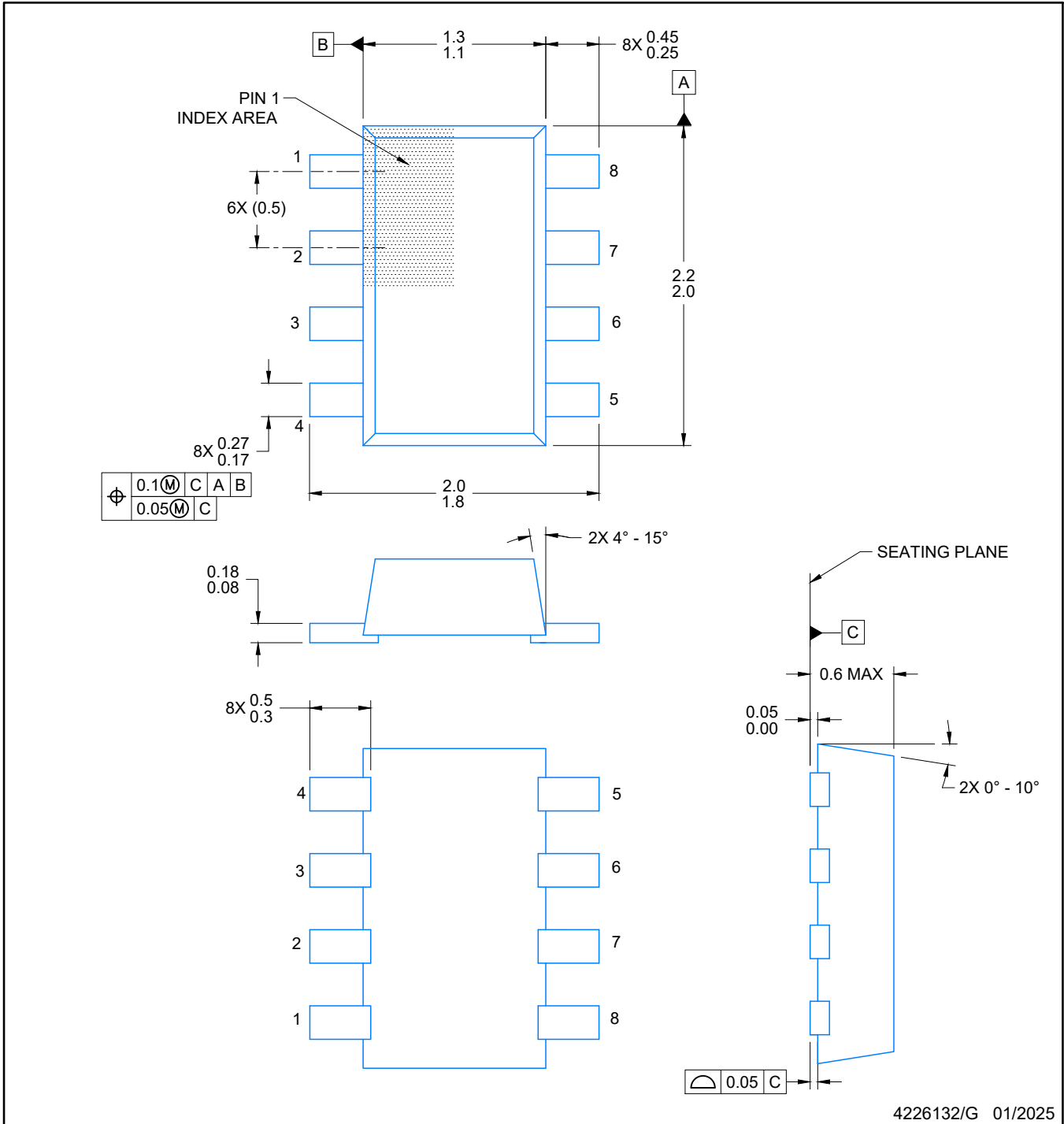

4226132/G 01/2025

NOTES:

1. All linear dimensions are in millimeters. Any dimensions in parenthesis are for reference only. Dimensioning and tolerancing per ASME Y14.5M.
2. This drawing is subject to change without notice.
3. Body dimensions do not include mold flash, protrusions or gate burrs. Mold flash, interlead flash, protrusions or gate burrs shall not exceed 0.171 per end or side.
4. The side flash along with the stub lead is allowed.
5. Any detached side flash from the stub lead is allowed unless it is touching the bottom side of the lead.

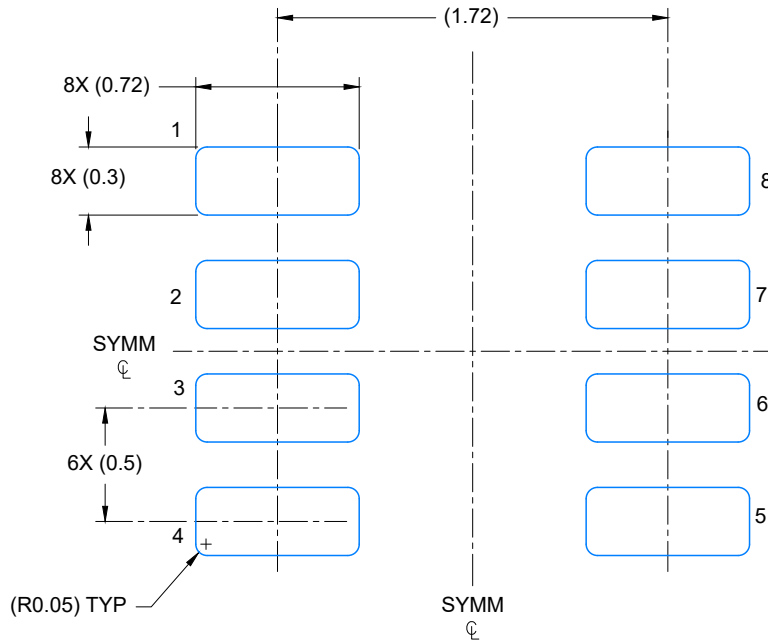

LAND PATTERN EXAMPLE
EXPOSED METAL SHOWN
SCALE: 30X

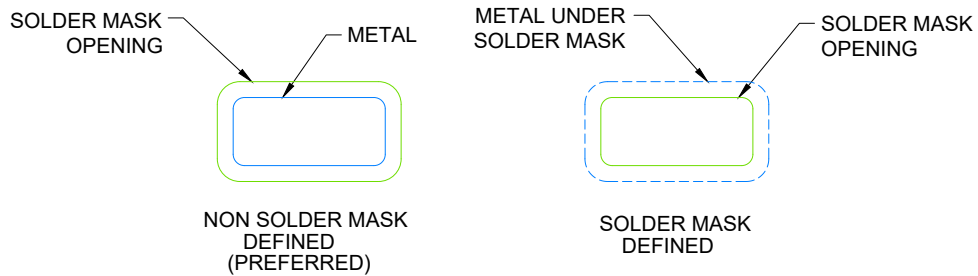

SOLDER MASK DETAILS

4226132/G 01/2025

NOTES: (continued)

- 6. Publication IPC-7351 may have alternate designs.
- 7. Solder mask tolerances between and around signal pads can vary based on board fabrication site.
- 8. Land pad design aligns to IPC-610, Bottom Termination Component (BTC) solder joint inspection criteria.

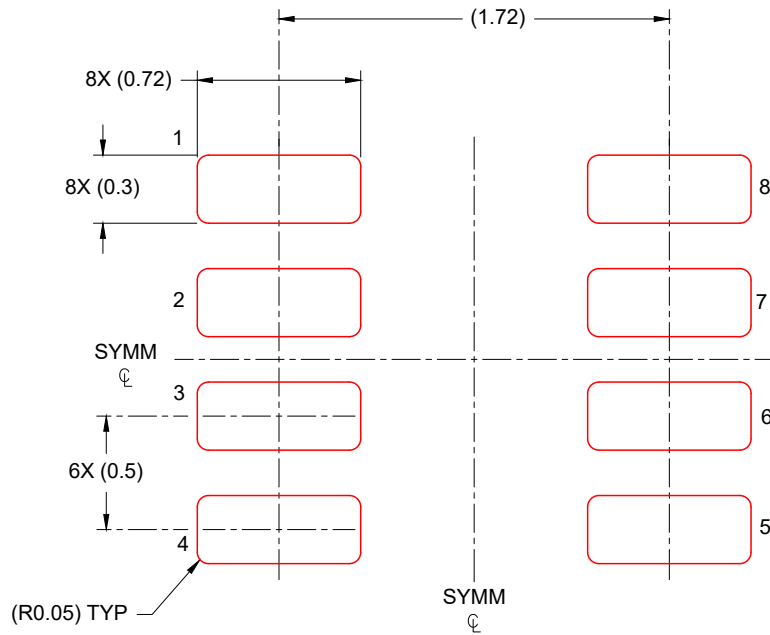

SOLDER PASTE EXAMPLE
BASED ON 0.125 mm THICK STENCIL
SCALE: 30X

4226132/G 01/2025

NOTES: (continued)

- 9. Laser cutting apertures with trapezoidal walls and rounded corners may offer better paste release. IPC-7525 may have alternate design recommendations.
- 10. Board assembly site may have different recommendations for stencil design.

IMPORTANT NOTICE AND DISCLAIMER

TI PROVIDES TECHNICAL AND RELIABILITY DATA (INCLUDING DATA SHEETS), DESIGN RESOURCES (INCLUDING REFERENCE DESIGNS), APPLICATION OR OTHER DESIGN ADVICE, WEB TOOLS, SAFETY INFORMATION, AND OTHER RESOURCES "AS IS" AND WITH ALL FAULTS, AND DISCLAIMS ALL WARRANTIES, EXPRESS AND IMPLIED, INCLUDING WITHOUT LIMITATION ANY IMPLIED WARRANTIES OF MERCHANTABILITY, FITNESS FOR A PARTICULAR PURPOSE OR NON-INFRINGEMENT OF THIRD PARTY INTELLECTUAL PROPERTY RIGHTS.

These resources are intended for skilled developers designing with TI products. You are solely responsible for (1) selecting the appropriate TI products for your application, (2) designing, validating and testing your application, and (3) ensuring your application meets applicable standards, and any other safety, security, regulatory or other requirements.

These resources are subject to change without notice. TI grants you permission to use these resources only for development of an application that uses the TI products described in the resource. Other reproduction and display of these resources is prohibited. No license is granted to any other TI intellectual property right or to any third party intellectual property right. TI disclaims responsibility for, and you will fully indemnify TI and its representatives against, any claims, damages, costs, losses, and liabilities arising out of your use of these resources.

TI's products are provided subject to [TI's Terms of Sale](#) or other applicable terms available either on [ti.com](https://www.ti.com) or provided in conjunction with such TI products. TI's provision of these resources does not expand or otherwise alter TI's applicable warranties or warranty disclaimers for TI products.

TI objects to and rejects any additional or different terms you may have proposed.

Mailing Address: Texas Instruments, Post Office Box 655303, Dallas, Texas 75265

Copyright © 2025, Texas Instruments Incorporated

Looking for pricing, stock, or lifecycle information?

Click below to explore more details on WIN SOURCE:

 [View OPT4060DTSR on WIN SOURCE](#)

 [Texas Instruments](#) Information

Optimize Your Supply Chain with WIN SOURCE Solutions

-  Global Sourcing Solution
-  Obsolete Management
-  Cost Control Management
-  Shortage Management
-  Alternative Solution
-  Excess Inventory Management