

IM - B Relay

- Minimum board-space 60mm²
- Slim line 10x6mm (0.39x0.24") and low profile 5.65mm (0.222")
- Switching power 60W/62.5VA
- Switching voltage 220VDC/250VAC
- Switching current 2A
- Bifurcated contacts
- High mechanical shock resistance

Typical applications

Telecommunication, access and transmission equipment, optical network terminals, modems, office and business equipment, consumer electronics, measurement and Test equipment, industrial control, medical equipment

Approvals

UL 508 File No. E 111441

Technical data of approved types on request

Contact Data

Contact arrangement	1 form A (1 NO)
Max. switching voltage	220VDC, 250VAC
Rated current	2A
Limiting continuous current	2A
Switching power	60W, 62.5VA
Contact material	PdRu
Contact style	Au covered twin contacts
Minimum switching voltage	100µV
Initial contact resistance	<100mΩ at 10mA/30mV
Thermoelectric potential	<10µV
Operate time	typ. 1ms, max. 3ms
Release time	
without diode in parallel	typ. 1ms, max. 3ms
with diode in parallel	typ. 3ms, max. 5ms
Bounce time max.	typ. 1ms, max. 5ms
Electrical endurance	
at contact application 0 (≤ 30mV / ≤ 10mA)	min. 2.5x10 ⁶ operations
cable load open end resistive, 125VDC / 0.24A - 30W	min. 2.0x10 ⁶ operations
resistive, 220 VDC / 0.27A - 60W	min. 5x10 ⁵ operations
resistive, 250VAC / 0.25A - 62.5VA	min. 1x10 ⁵ operations
resistive, 30VDC / 1A - 30W	min. 5x10 ⁵ operations
resistive, 30VDC / 2A - 60W	min. 1x10 ⁵ operations

Contact data (continued)

UL contact rating 30VDC, 2A, 60W, NO only

Max. DC load breaking capacity

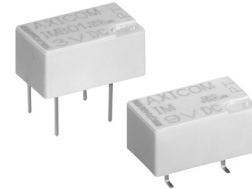
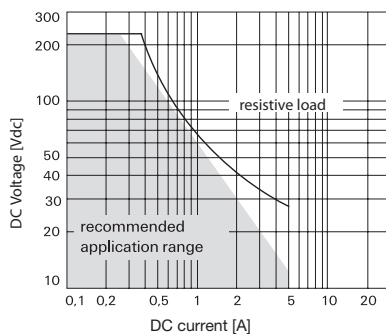

IM_AB



110VDC, 0.3A, 33W
220VDC, 0.27A, 60W
125VAC, 0.5A, 62.5W
250VAC, 0.25A, 62.5W

Mechanical endurance 10⁸ operations

Coil Data

Magnetic system	monostable, bistable
Coil voltage range	1.5 to 24VDC
Max. coil temperature	125°C
Thermal resistance	<150K/W

Coil versions, standard version, monostable, 1 coil

Coil code	Rated voltage VDC	Operate voltage VDC	Release voltage VDC	Coil resistance Ω±10%	Rated coil power mW
01	3.0	2.25	0.30	64	140
02	4.5	3.38	0.45	145	140
03	5.0	3.75	0.50	178	140
06	12.0	9.00	1.20	1029	140

All figures are given for coil without pre-energization, at ambient temperature +23°C

Insulation

C*

Coil operating range

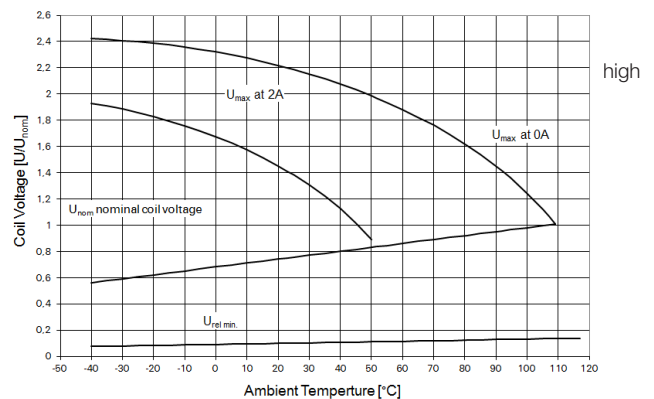

IM - B Relay (Continued)

dielectric version	
Initial dielectric strength	
between open contacts	2500Vrms
between contact and coil	3500Vrms
Initial surge withstand voltage	
between open contacts	3500V
between contact and coil	4900V
Initial insulation resistance	
between insulated elements	>10 ⁹ Ω
Capacitance	
between open contacts	max. 1pF
between contact and coil	max. 2pF
between adjacent contacts	max. 2pF

*this relay contains SF6 (Sulfur hexafluoride, CAS number: 2551-62-4) for dielectric strength enhancement, SF6 is hermetically sealed in relay without leaks to air during normal application as recommended per the applicable product specification. It is clarified that the usage of SF6 in mini signal relay is not prohibited by related regulations. Please contact TE local sales or field engineer for further information and detailed material declaration.

RF Data

Isolation at 100MHz/900MHz	37.0dB/18.8dB
Insertion loss at 100MHz/900MHz	0.03dB/0.33dB
Voltage standing wave ratio (VSWR) at 100MHz/900MHz	1.06/1.49

Other Data

Material compliance: EU RoHS/ELV, China RoHS, REACH, Halogen content refer to the Product Compliance Support Center at www.te.com/customersupport/rohssupportcenter

Ambient temperature	-40°C to +85°C
Thermal resistance	< 150K/W
Category of environmental protection IEC 61810	RT V - hermetically sealed
Degree of protection IEC 60529	IP 67, immersion cleanable
Vibration resistance (functional)	20g, 10 to 500Hz
Shock resistance (functional), half sinus 11ms	50g
Shock resistance (destructive), half sinus 0.5ms	500g
Weight	max. 0.75g
Resistance to soldering heat THT IEC 60068-2-20	265°C/10s
Resistance to soldering heat SMT IEC 60068-2-58	265°C/10s
Moisture sensitive level, JEDEC J-Std-020D	MSL3
Ultrasonic cleaning	not recommended
Packaging/unit	
THT version	tube/50pcs., box/1000 pcs.
SMT version	reel/1000 pcs., box/1000 or 5000 pcs.

Terminal assignment

TOP view on relay

IM-B, 1 form A (NO)

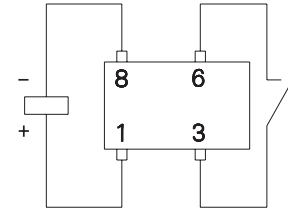

Contacts are shown in reset condition. Contact position might change during transportation and must be reset before use.

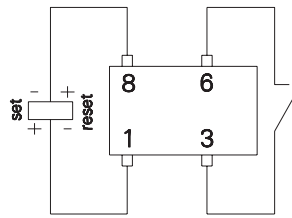

Dimensions

THT version

Standard version

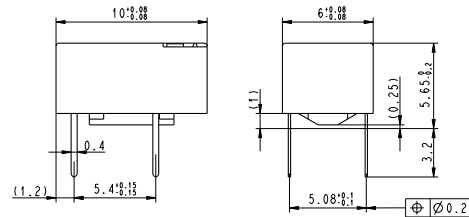

SMT version

Gull wings

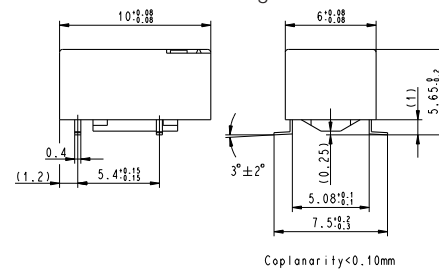

PCB layout

TOP view on component side of PCB

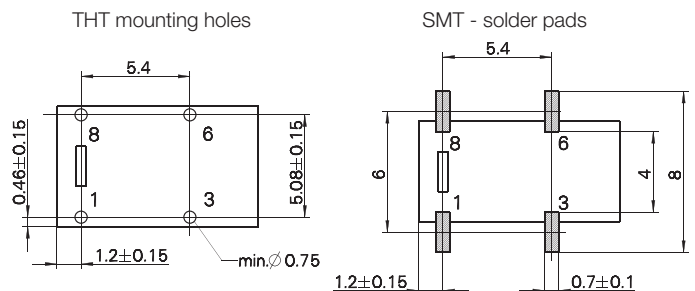

IM - B Relay (Continued)

Processing Recommended soldering conditions

Soldering conditions according IEC 60058-2-58 and IPC/JEDEC J-STD-020D

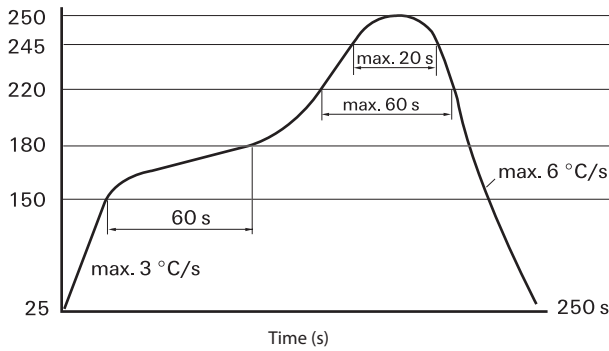

Resistance to soldering heat - Reflow profile
Infrared Soldering: temperature/time profile (lead and housing peak temperature)

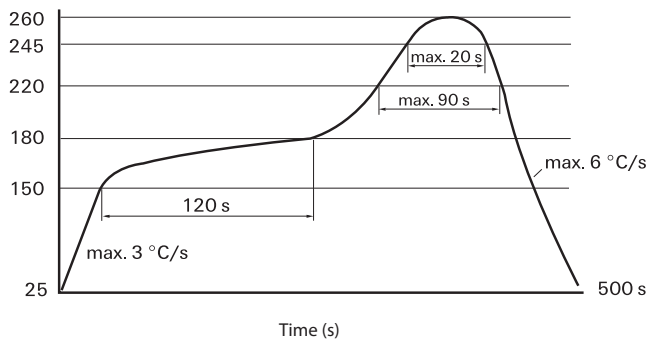

Recommended reflow soldering profile

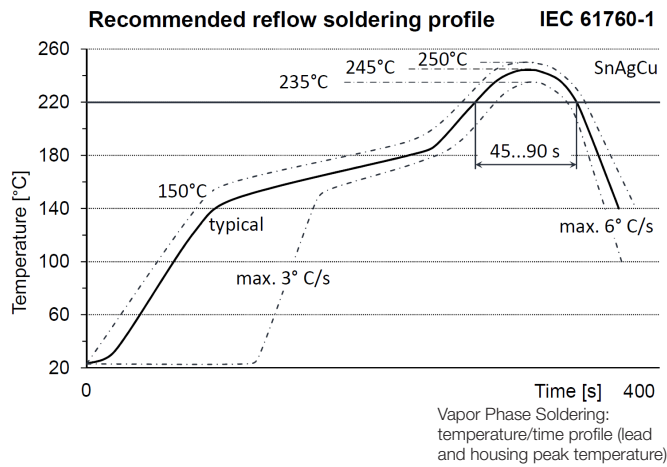

Packing

Tube for THT version
50 relays per tube, 1000 relays per box

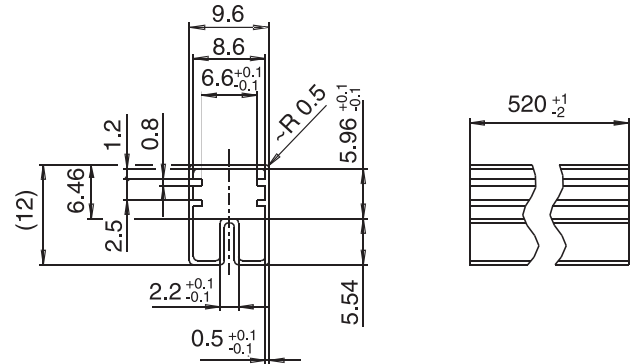

Tape and reel for SMT version
1000 relays per reel, 1000 or 5000 relays per box

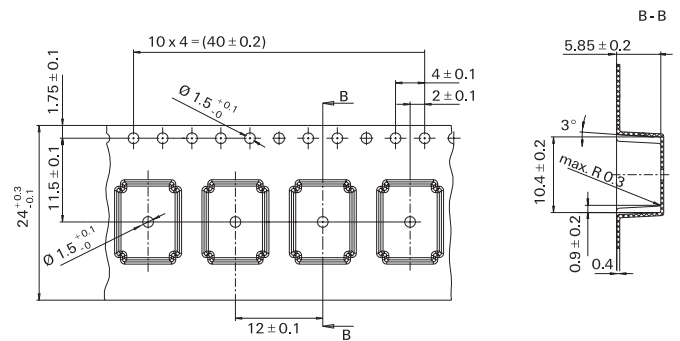

Reel dimensions

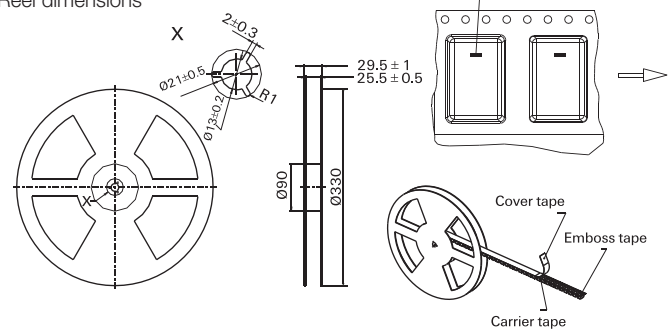

IM - B Relay (Continued)

Product code structure	Typical product code	IM	B	03	G	R
Type	IM Signal Relays IM Series IMA/IMB					
Contact arrangement	B 1 form A, 1 NO					
Coil	Coil code: please refer to coil versions table					
Performance type	Blank Standard version		C High Dielectric Version			
Terminals	T THT - standard		G SMT-gull wing			
Packing	S Tube		R Reel			

Product code	Arrangement	Perf. type	Coil	Coil type	Terminals	Part number
IMB01CGR	1 form A,	High dielectric	3VDC	Monostable	SMT gull wing	1462041-1
IMB01CTS	1 NO				THT standard	1462041-4
IMB02CGR	contact		4.5VDC		SMT gull wing	1462041-2
IMB02CTS					THT standard	1462041-5
IMB03CGR			5VDC		SMT gull wing	1462041-7
IMB03CTS					THT standard	1462041-8
IMB04CGR			6VDC		SMT gull wing	1462041-9
IMB06CGR			12VDC			1462041-3
IMB06CTS					THT standard	1462041-6
IMB07CGR			24VDC		SMT gull wing	1-1462041-3
IMB07CTS					THT standard	1-1462041-4
IMB42CGR			4.5VDC	Bistable	SMT gull wing	1-1462041-6
IMB42CTS					THT standard	1-1462041-5

Looking for pricing, stock, or lifecycle information?

Click below to explore more details on WIN SOURCE:

 [View 1462041-3 on WIN SOURCE](#)

 [TE Connectivity](#) Information

Optimize Your Supply Chain with WIN SOURCE Solutions

-  Global Sourcing Solution
-  Obsolete Management
-  Cost Control Management
-  Shortage Management
-  Alternative Solution
-  Excess Inventory Management