

87117283
(ON DRAWING NO.)

版数 VER.	年月日 DATE	CN NO.	変更内容 DESCRIPTION	製図 DR.	担当 CHK.	査閲 APPD.	承認 APPD.
2	16/JAN/2018	023412	Form change of cover		K. MIKAWA	-	M. SHIMADA

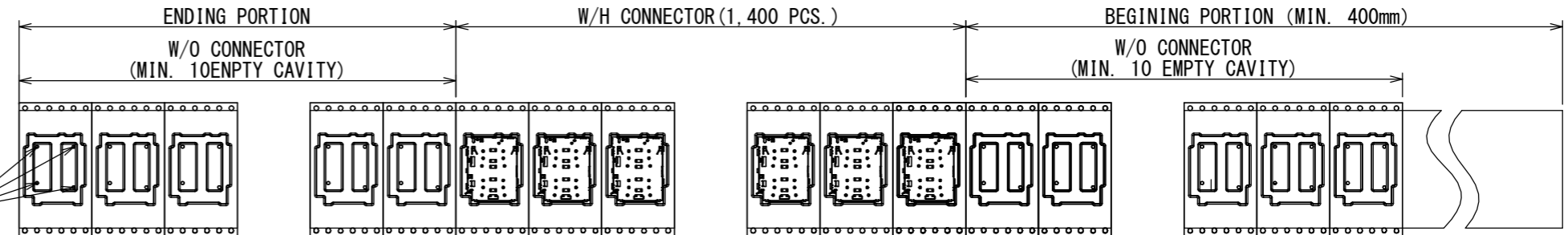
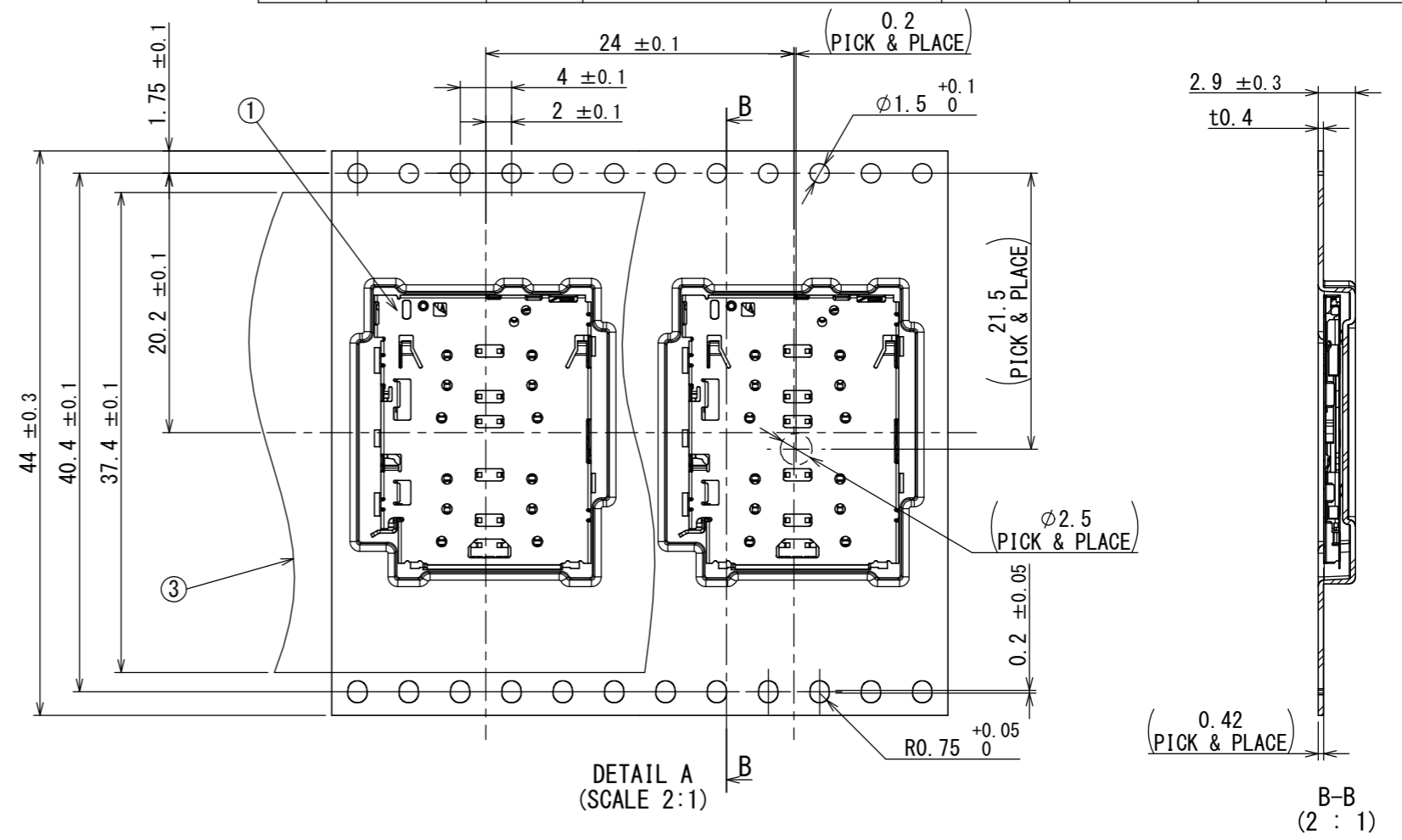
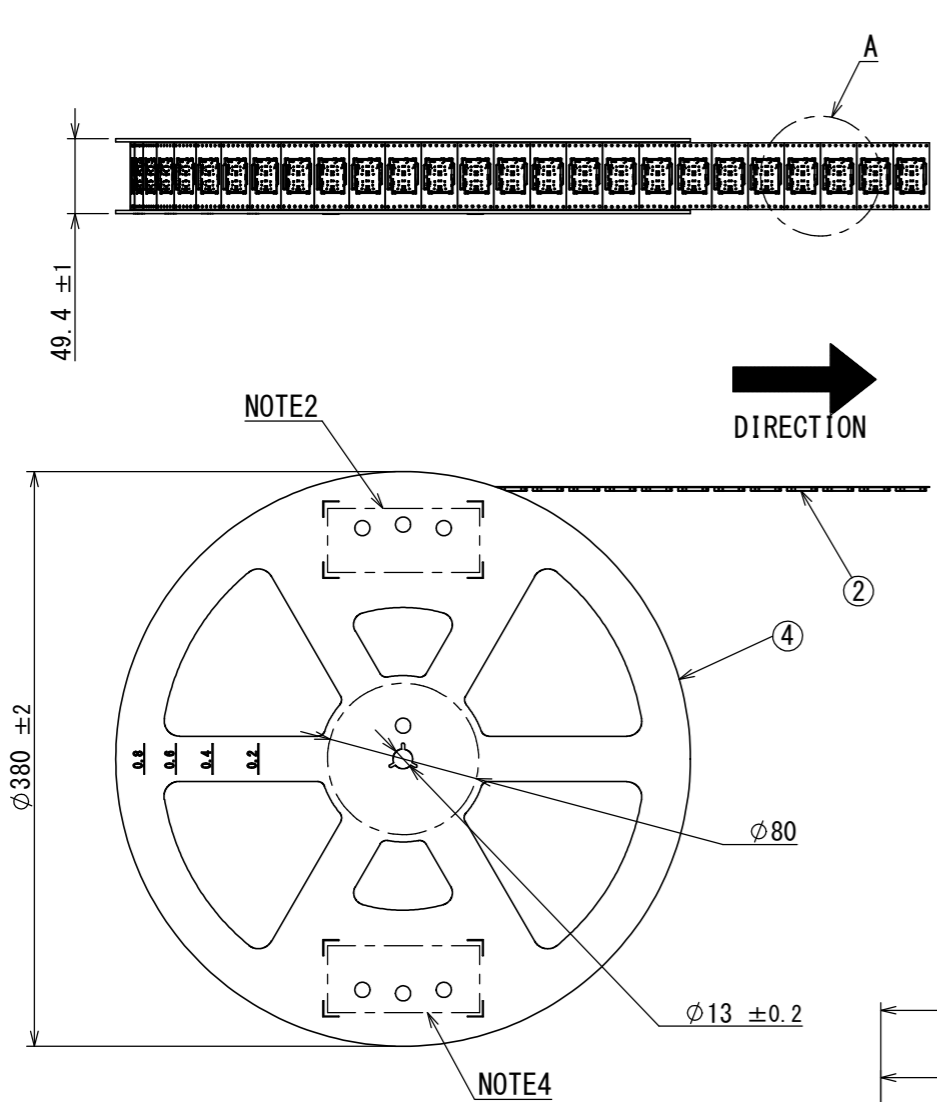

NOTE1. SUFFIX "R1400" OF THE PART NUMBER INDICATES THAT 1400 PCS. OF SF78S012VBA CONNECTORS ARE ACCOMODATED IN ONE REEL.
 2. THE LABEL IS TO BE ATTACHED ON THE MAGAZINE AS SHOWN, AND DESCRIPTION, QTY, LOT NO, EMBOSS CODE ARE SHOWN.
 3. REFER TO THE DRAWING, SJ117282 (SF78S012VBA) FOR THE DIMENSION OF THE CONNECTOR.
 4. IF THERE IS ANOTHER ASSIGNED LABEL, THE LABEL IS TO BE ATTACHED. (REFER TO JACS)

NOTE2.
 DESCRIPTION: SF78S012VBAR1400
 QTY : 1400
 LOT NO : DDMMYY-*(*: REEL No.)
 EMBOSS CODE: TB44 24
 24: PITCH
 44: TAPE WIDTH

符号 NO.	名称 DESCRIPTION	個数 QTY.	材料 MATERIAL	仕上 FINISH	備考 REMARKS
4	REEL	1	PLASTIC	-	
3	COVER TAPE	1	POLYESTER	-	
2	CARRIER TAPE	1	PS	-	
1	CONNECTOR	1400	-	-	SJ117282 (SF78S012VBA)

仕様書 (SPECIFICATION) JACS-11140	第1版 (ORIGINAL DATE) 03/JUN/2016	尺度 (SCALE) 1:5	シリーズ (SERIES) SF78	日本航空電子工業株式会社 JAE
一般公差 (GENERAL TOLERANCE) 寸法 (DIMENSION) ±0.8 × ±0.4 ×× ±0.1 ××× ±	角度 (ANGLES) ×° ± ×°×' ± 単位 (UNIT) : mm	製図 DR. 担当 CHK. K. MIKAWA 査閲 APPD. K. KUME 承認 APPD. M. SHIMADA	名称 (TITLE) SF78S012VBAR1400	JAPAN AVIATION ELECTRONICS INDUSTRY, LTD.
			質量 (MASS) -	図面番号 (DRAWING NO.) SJ117283

DCF-C-212H(12.08)

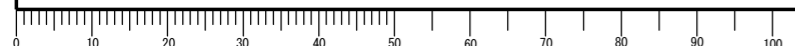

WISDOM承認 2018/01/23

Looking for pricing, stock, or lifecycle information?

Click below to explore more details on WIN SOURCE:

[View SF78S012VBAR1400 on WIN SOURCE](#)

[JAE Electronics Information](#)

Optimize Your Supply Chain with WIN SOURCE Solutions

- ✓ Global Sourcing Solution
- ✓ Obsolete Management
- ✓ Cost Control Management
- ✓ Shortage Management
- ✓ Alternative Solution
- ✓ Excess Inventory Management