



Aluminum electrolytic capacitors

Snap-in capacitors

Series/Type: B43644
Date: October 2022

Long-life grade capacitors

Applications

- Frequency converters
- Solar inverters
- Uninterruptible power supplies
- Professional power supplies
- Medical appliances
- Not for automotive applications unless otherwise specified



Features

- Extremely high CV product, Very compact
- High reliability
- Long useful life
- High ripple current capability
- Capacitors with all insulation versions pass the needle flame test according to IEC 60695-11-5 for all flame exposure times up to 120 s
- RoHS-compatible

Construction

- Charge/discharge-proof, polar
- Aluminum case, fully insulated with PET
- Version with PVC insulation available upon request
- Version with PVC insulation and additional PET insulation cap on terminal side available for insulating the capacitor from the PCB
- Other case dimensions with length $l > 55$ mm are available upon request
- Snap-in solder pins to hold component in place on PC-board
- Minus pole marking on case surface
- Minus pole not insulated from case
- Overload protection by safety vent on the base

Terminals

- Standard version with 2 terminals, 2 lengths available: 6.3 and 4.5 mm
- 3 terminals to ensure correct insertion: length 4.5 mm

Specifications and characteristics in brief

Rated voltage V_R	200 ... 500 V DC														
Surge voltage V_S	$1.15 \cdot V_R$ (for $V_R \leq 250$ V DC) $1.10 \cdot V_R$ (for $V_R \geq 400$ V DC)														
Rated capacitance C_R	47 ... 2700 μ F														
Capacitance tolerance	$\pm 20\% \triangleq M$														
Dissipation factor $\tan \delta$ (20 °C, 120 Hz)	$V_R \leq 250$ V DC: $\tan \delta \leq 0.15$ $V_R \geq 400$ V DC: $\tan \delta \leq 0.20$														
Leakage current I_{leak} (5 min, 20 °C)	$I_{leak} \leq 0.3 \mu A \cdot \left(\frac{C_R}{\mu F} \cdot \frac{V_R}{V} \right)^{0.7} + 4 \mu A$														
Self-inductance ESL	Approx. 20 nH														
Useful life ¹⁾ 105 °C; V_R ; $I_{AC,R}$	> 5000 h	Requirements: $ \Delta C/C \leq 20\%$ of initial value $\tan \delta \leq 2$ times initial specified limit $I_{leak} \leq$ initial specified limit													
Voltage endurance test 105 °C; V_R	2000 h	Post test requirements: $ \Delta C/C \leq 10\%$ of initial value $\tan \delta \leq 1.3$ times initial specified limit $I_{leak} \leq$ initial specified limit													
Vibration resistance test (standard version)	To IEC 60068-2-6, test Fc: Frequency range 10 Hz ... 55 Hz, displacement amplitude 0.35 mm, acceleration max. 5 g, duration 3 × 2 h. Capacitor mounted by its body which is rigidly clamped to the work surface.														
Characteristics at low temperature	Max. impedance ratio at 100 Hz	<table border="1"> <thead> <tr> <th>V_R</th> <th>≤ 250 V</th> <th>400 ... 450 V</th> <th>500 V</th> </tr> </thead> <tbody> <tr> <td>$Z_{-25^\circ C} / Z_{20^\circ C}$</td> <td>3</td> <td>5</td> <td>7</td> </tr> <tr> <td>$Z_{-40^\circ C} / Z_{20^\circ C}$</td> <td>7</td> <td>10</td> <td>14</td> </tr> </tbody> </table>	V_R	≤ 250 V	400 ... 450 V	500 V	$Z_{-25^\circ C} / Z_{20^\circ C}$	3	5	7	$Z_{-40^\circ C} / Z_{20^\circ C}$	7	10	14	
V_R	≤ 250 V	400 ... 450 V	500 V												
$Z_{-25^\circ C} / Z_{20^\circ C}$	3	5	7												
$Z_{-40^\circ C} / Z_{20^\circ C}$	7	10	14												
IEC climatic category	To IEC 60068-1: $V_R \leq 450$ V DC: 40/105/56 (–40 °C/+105 °C/56 days damp heat test) $V_R = 500$ V DC: 25/105/56 (–25 °C/+105 °C/56 days damp heat test) The capacitors can be operated in the temperature range of –40 °C to +105 °C but the impedance at –40 °C must be taken into consideration.														
Sectional specification	IEC 60384-4														

1) Refer to chapter "General technical information, 5 Useful life" on how to interpret useful life.

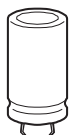

B43644

Very compact, long useful life – 105 °C

Dimensional drawings

Snap-in capacitors with standard insulation (PET)

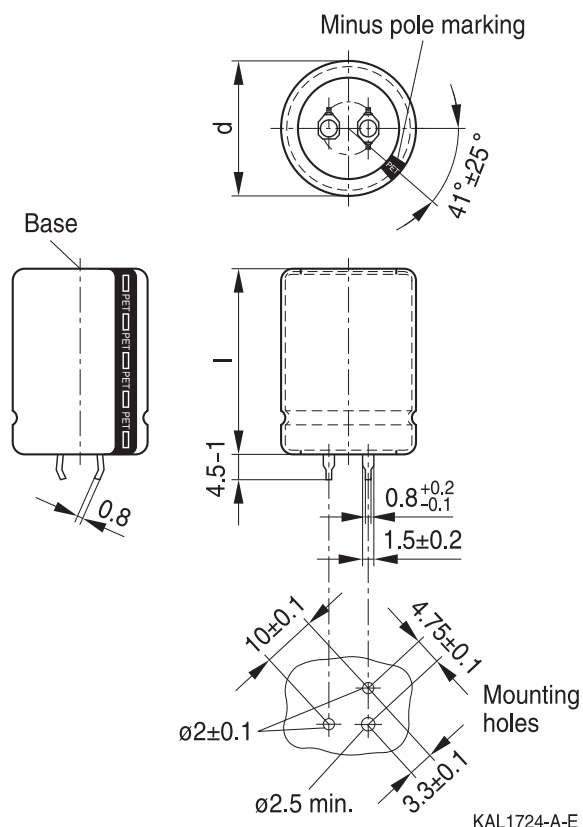
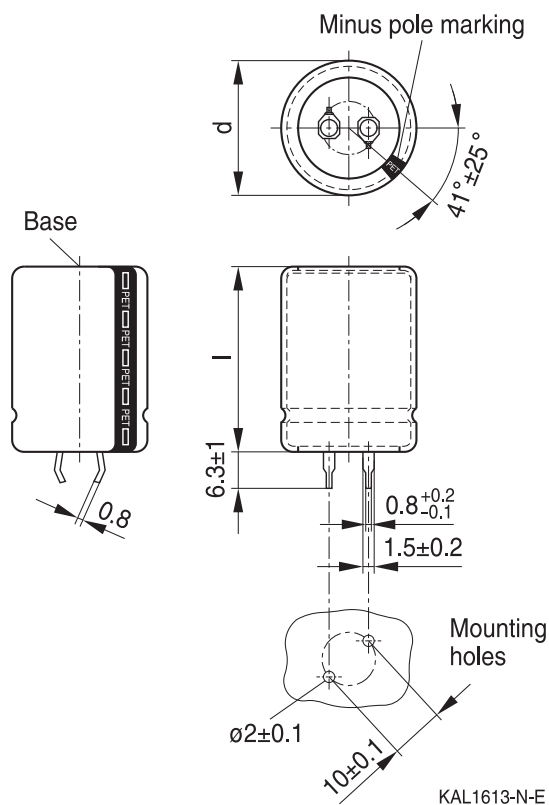

Snap-in terminals, length (6.3 ± 1) mm.
 Also available in a shorter version with a length of (4.5 – 1) mm.
 Insulation is marked with "PET" on the sleeve.
 Safety vent on the base.

Snap-in capacitors are also available with 3 terminals (length (4.5 – 1) mm).
 Insulation is marked with "PET" on the sleeve.
 Safety vent on the base.

Dimensions (mm)		Approx. weight (g)	Packing units (pcs.)
d + 1	l ± 2		
22	25	9	160
22	30	12	160
22	35	15	160
22	40	18	160
22	45	20	160
22	50	24	160
<hr/>			
25	25	13	130
25	30	17	130
25	35	19	130
25	40	22	130
25	45	25	130
25	50	29	130
25	55	32	130

Dimensions (mm)		Approx. weight (g)	Packing units (pcs.)
d + 1	l ± 2		
30	25	17	80
30	30	23	80
30	35	29	80
30	40	36	80
30	45	41	80
30	50	46	80
30	55	53	80
35	25	22	60
35	30	29	60
35	35	36	60
35	40	41	60
35	45	56	60
35	50	70	60
35	55	81	60

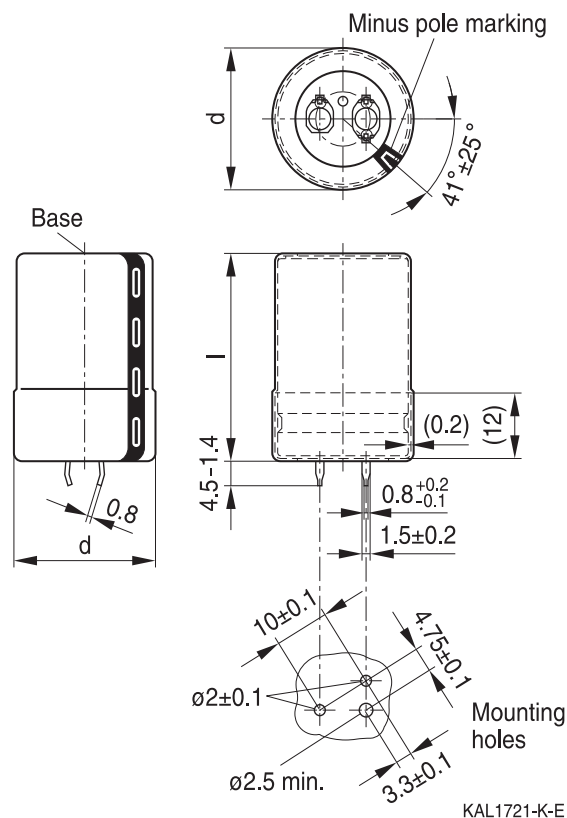
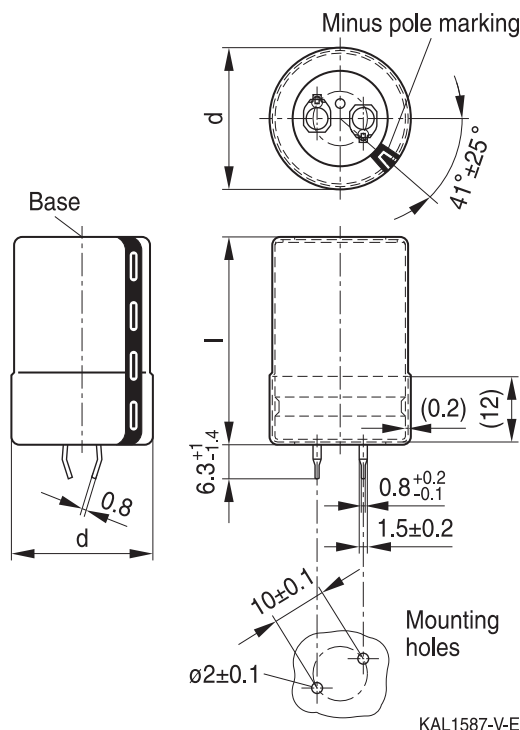

Snap-in capacitors with PVC insulation and PET insulation cap on terminal side

Snap-in terminals, length (6.3 +1/-1.4) mm. Also available in a shorter version with a length of (4.5 - 1.4) mm. PET insulation cap is positioned under the insulation sleeve. Safety vent on the base.

Snap-in capacitors are also available with 3 terminals (length (4.5 - 1.4) mm). PET insulation cap is positioned under the insulation sleeve. Safety vent on the base.

Dimensions (mm)		Approx. weight (g)	Packing units (pcs.)
d +1.4	l +2.2/-2		
22	25	9	160
22	30	12	160
22	35	15	160
22	40	18	160
22	45	20	160
22	50	24	160
25	25	13	115
25	30	17	115
25	35	19	115
25	40	22	115
25	45	25	115
25	50	29	115
25	55	32	115

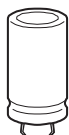
Dimensions (mm)		Approx. weight (g)	Packing units (pcs.)
d +1.4	l +2.2/-2		
30	25	17	80
30	30	23	80
30	35	29	80
30	40	36	80
30	45	41	80
30	50	46	80
30	55	53	80
35	25	22	60
35	30	29	60
35	35	36	60
35	40	41	60
35	45	56	60
35	50	70	60
35	55	81	60



B43644

Very compact, long useful life – 105 °C

Packing of snap-in capacitors



For ecological reasons the packing is pure cardboard.

Ordering codes for terminal styles and insulation features

Identification in 3rd block of ordering code

Snap-in capacitors

Terminal version	Insulation version	
	PET	PVC plus PET cap
Standard terminals 6.3 mm	M060	M080
Short terminals 4.5 mm	M067	M087
3 terminals 4.5 mm	M062	M082

Ordering examples:

- B43644A5107M067 } snap-in capacitor with short terminals and PET insulation
- B43644A5107M062 } snap-in capacitor with 3 terminals and PET insulation
- B43644A5107M080 } snap-in capacitor with standard terminals and PVC insulation with additional PET insulation cap on terminal side



Overview of available types

The capacitance and voltage ratings listed below are available in different case sizes upon request. Other voltage and capacitance ratings are also available upon request.

V_R (V DC)	200	250	400	450	500
	Case dimensions $d \times l$ (mm)				
C_R (μ F)					
47					22 × 25
56					22 × 30
68				22 × 25	22 × 30 25 × 25
82				22 × 25	22 × 35 25 × 30
100			22 × 25	22 × 30 25 × 25	22 × 40 25 × 35 30 × 25
120			22 × 30 25 × 25	22 × 35 25 × 25	22 × 45 25 × 35 30 × 30
150			22 × 30 25 × 25	22 × 40 25 × 30 30 × 25	25 × 45 30 × 30 35 × 25
180			22 × 35 25 × 30 30 × 25	22 × 45 25 × 35 30 × 25	25 × 50 30 × 35 35 × 30
220		22 × 25	22 × 40 25 × 35 30 × 25	22 × 50 25 × 40 30 × 30 35 × 25	25 × 55 30 × 40 35 × 35
270		22 × 30	22 × 50 25 × 40 30 × 30 35 × 25	25 × 45 30 × 35 35 × 30	30 × 50 35 × 40
330	22 × 25	22 × 30 25 × 25	25 × 45 30 × 35 35 × 25	25 × 55 30 × 40 35 × 30	30 × 55 35 × 45
390	22 × 30	22 × 35 25 × 30	25 × 50 30 × 35 35 × 30	30 × 45 35 × 35	35 × 50
470	22 × 30 25 × 25	22 × 40 25 × 30 30 × 25	30 × 45 35 × 35	30 × 50 35 × 40	35 × 55

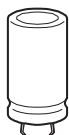

B43644

Very compact, long useful life – 105 °C

Overview of available types

The capacitance and voltage ratings listed below are available in different case sizes upon request. Other voltage and capacitance ratings are also available upon request.

V_R (V DC)	200	250	400	450	500
	Case dimensions $d \times l$ (mm)				
C_R (μ F)					
560	22 × 35 25 × 30	22 × 45 25 × 35 30 × 30	30 × 50 35 × 40	35 × 45	
680	22 × 40 25 × 35 30 × 25	22 × 50 25 × 40 30 × 30 35 × 25	30 × 55 35 × 45	35 × 55	
820	22 × 45 25 × 40 30 × 30	25 × 45 30 × 35 35 × 30	35 × 50		
1000	25 × 45 30 × 35 35 × 25	25 × 55 30 × 40 35 × 30			
1200	25 × 50 30 × 35 35 × 30	30 × 45 35 × 35			
1500	30 × 45 35 × 35	30 × 55 35 × 40			
1800	30 × 50 35 × 40	35 × 50			
2200	30 × 55 35 × 45	35 × 55			
2700	35 × 50				

Technical data and ordering codes

C_R 100 Hz 20 °C μF	Case dimensions $d \times l$ mm	ESR_{typ} 100 Hz 20 °C $\text{m}\Omega$	ESR_{typ} 300 Hz 60 °C $\text{m}\Omega$	Z_{max} 10 kHz 20 °C $\text{m}\Omega$	$I_{\text{AC,max}}$ 100 Hz 60 °C A	$I_{\text{AC,max}}$ 100 Hz 85 °C A	$I_{\text{AC,R}}$ 100 Hz 105 °C A	Ordering code (composition see below)
$V_R = 200 \text{ V DC}$								
330	22 × 25	290	100	440	2.71	2.01	1.10	B43644A2337M0*#
390	22 × 30	250	80	370	3.08	2.29	1.25	B43644A2397M0*#
470	22 × 30	210	70	310	3.54	2.62	1.42	B43644A2477M0*#
470	25 × 25	220	80	330	3.31	2.46	1.34	B43644B2477M0*#
560	22 × 35	170	60	260	4.07	3.01	1.64	B43644A2567M0*#
560	25 × 30	180	65	270	3.80	2.82	1.54	B43644B2567M0*#
680	22 × 40	140	50	220	4.75	3.51	1.91	B43644A2687M0*#
680	25 × 35	150	50	220	4.42	3.28	1.79	B43644B2687M0*#
680	30 × 25	170	75	260	3.87	2.88	1.56	B43644C2687M0*#
820	22 × 45	120	40	180	5.53	4.09	2.22	B43644A2827M0*#
820	25 × 40	120	45	190	5.11	3.80	2.07	B43644B2827M0*#
820	30 × 30	130	55	210	4.51	3.36	1.83	B43644C2827M0*#
1000	25 × 45	100	36	160	5.97	4.43	2.41	B43644A2108M0*#
1000	30 × 35	110	45	170	5.23	3.90	2.12	B43644B2108M0*#
1000	35 × 25	140	80	220	4.33	3.22	1.74	B43644C2108M0*#
1200	25 × 50	85	32	130	6.89	5.10	2.77	B43644A2128M0*#
1200	30 × 35	100	45	160	5.74	4.27	2.31	B43644B2128M0*#
1200	35 × 30	110	60	170	5.09	3.80	2.19	B43644C2128M0*#
1500	30 × 45	75	34	120	7.03	5.23	3.02	B43644A2158M0*#
1500	35 × 35	90	50	140	5.95	4.44	2.56	B43644B2158M0*#
1800	30 × 50	65	30	100	8.02	5.96	3.43	B43644A2188M0*#
1800	35 × 40	75	40	120	6.80	5.07	2.92	B43644B2188M0*#
2200	30 × 55	55	26	85	9.24	6.86	3.94	B43644A2228M0*#
2200	35 × 45	60	36	100	7.76	5.79	3.33	B43644B2228M0*#
2700	35 × 50	55	32	85	8.86	6.59	3.78	B43644A2278M0*#

Composition of ordering code

* = Insulation feature

6 = PET insulation

 8 = PVC insulation with additional PET insulation
cap on terminal side

= Terminal style

0 = snap-in standard terminals (6.3 mm)

2 = snap-in 3 terminals (4.5 mm)

7 = snap-in short terminals (4.5 mm)

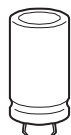

B43644

Very compact, long useful life – 105 °C

Technical data and ordering codes

C_R 100 Hz 20 °C μF	Case dimensions $d \times l$ mm	ESR_{typ} 100 Hz 20 °C $\text{m}\Omega$	ESR_{typ} 300 Hz 60 °C $\text{m}\Omega$	Z_{max} 10 kHz 20 °C $\text{m}\Omega$	$I_{\text{AC,max}}$ 100 Hz 60 °C A	$I_{\text{AC,max}}$ 100 Hz 85 °C A	$I_{\text{AC,R}}$ 100 Hz 105 °C A	Ordering code (composition see below)
$V_R = 250 \text{ V DC}$								
220	22 × 25	350	110	500	2.25	1.68	0.91	B43644E2227M0*#
270	22 × 30	290	90	400	2.63	1.96	1.07	B43644E2277M0*#
330	22 × 30	240	80	340	3.07	2.28	1.24	B43644E2337M0*#
330	25 × 25	250	90	350	2.91	2.17	1.18	B43644F2337M0*#
390	22 × 35	200	65	290	3.50	2.60	1.41	B43644E2397M0*#
390	25 × 30	210	70	290	3.31	2.47	1.34	B43644F2397M0*#
470	22 × 40	170	55	240	4.07	3.02	1.64	B43644E2477M0*#
470	25 × 30	180	65	250	3.78	2.80	1.52	B43644F2477M0*#
470	30 × 25	190	80	270	3.47	2.59	1.40	B43644G2477M0*#
560	22 × 45	140	45	200	4.70	3.48	1.89	B43644E2567M0*#
560	25 × 35	150	55	210	4.33	3.22	1.74	B43644F2567M0*#
560	30 × 30	150	60	220	3.99	2.98	1.62	B43644G2567M0*#
680	22 × 50	120	40	170	5.51	4.08	2.21	B43644E2687M0*#
680	25 × 40	120	45	180	5.05	3.75	2.03	B43644F2687M0*#
680	30 × 30	130	60	200	4.44	3.31	1.79	B43644G2687M0*#
680	35 × 25	150	80	230	4.00	2.99	1.61	B43644H2687M0*#
820	25 × 45	100	40	150	5.87	4.35	2.35	B43644E2827M0*#
820	30 × 35	110	50	170	5.13	3.82	2.07	B43644F2827M0*#
820	35 × 30	120	60	180	4.68	3.50	2.02	B43644G2827M0*#
1000	25 × 55	80	30	120	6.95	5.16	2.79	B43644E2108M0*#
1000	30 × 40	90	40	140	5.96	4.44	2.56	B43644F2108M0*#
1000	35 × 30	110	65	170	5.04	3.76	2.16	B43644G2108M0*#
1200	30 × 45	75	36	120	6.85	5.09	2.93	B43644E2128M0*#
1200	35 × 35	90	50	140	5.82	4.34	2.49	B43644F2128M0*#
1500	30 × 55	60	28	95	8.24	6.13	3.53	B43644E2158M0*#
1500	35 × 40	75	45	120	6.78	5.05	2.89	B43644F2158M0*#
1800	35 × 50	60	32	90	8.06	6.02	3.46	B43644E2188M0*#
2200	35 × 55	50	30	80	9.21	6.85	3.93	B43644E2228M0*#

Composition of ordering code

* = Insulation feature

6 = PET insulation

8 = PVC insulation with additional PET insulation
cap on terminal side

= Terminal style

0 = snap-in standard terminals (6.3 mm)

2 = snap-in 3 terminals (4.5 mm)

7 = snap-in short terminals (4.5 mm)

Technical data and ordering codes

C_R 100 Hz 20 °C μF	Case dimensions $d \times l$ mm	ESR_{typ} 100 Hz 20 °C $\text{m}\Omega$	ESR_{typ} 300 Hz 60 °C $\text{m}\Omega$	Z_{max} 10 kHz 20 °C $\text{m}\Omega$	$I_{\text{AC,max}}$ 100 Hz 60 °C A	$I_{\text{AC,max}}$ 100 Hz 85 °C A	$I_{\text{AC,R}}$ 100 Hz 105 °C A	Ordering code (composition see below)
$V_R = 400 \text{ V DC}$								
100	22 × 25	870	230	1250	1.62	1.20	0.65	B43644A9107M0*#
120	22 × 30	730	190	1040	1.85	1.38	0.75	B43644A9127M0*#
120	25 × 25	730	200	1050	1.81	1.35	0.73	B43644B9127M0*#
150	22 × 30	620	150	900	2.19	1.63	0.88	B43644E9157M0*#
150	25 × 25	630	160	920	2.12	1.58	0.85	B43644F9157M0*#
180	22 × 35	520	130	750	2.52	1.88	1.01	B43644E9187M0*#
180	25 × 30	490	140	710	2.47	1.83	0.99	B43644B9187M0*#
180	30 × 25	500	150	730	2.39	1.78	0.97	B43644C9187M0*#
220	22 × 40	420	100	620	2.97	2.22	1.19	B43644E9227M0*#
220	25 × 35	400	110	580	2.88	2.14	1.16	B43644B9227M0*#
220	30 × 25	440	120	650	2.70	2.01	1.08	B43644F9227M0*#
270	22 × 50	320	90	470	3.60	2.66	1.44	B43644A9277M0*#
270	25 × 40	330	90	480	3.40	2.52	1.37	B43644B9277M0*#
270	30 × 30	340	110	500	3.19	2.37	1.28	B43644C9277M0*#
270	35 × 25	350	120	520	3.05	2.27	1.23	B43644D9277M0*#
330	25 × 45	290	75	420	3.91	2.92	1.57	B43644E9337M0*#
330	30 × 35	280	85	410	3.71	2.75	1.49	B43644B9337M0*#
330	35 × 25	320	110	480	3.38	2.52	1.36	B43644F9337M0*#
390	25 × 50	240	60	360	4.51	3.36	1.81	B43644E9397M0*#
390	30 × 35	250	75	380	4.11	3.07	1.65	B43644F9397M0*#
390	35 × 30	250	90	370	3.91	2.90	1.67	B43644C9397M0*#
470	30 × 45	200	60	290	4.89	3.63	2.09	B43644A9477M0*#
470	35 × 35	210	75	310	4.49	3.34	1.92	B43644B9477M0*#
560	30 × 50	170	55	240	5.63	4.18	2.41	B43644A9567M0*#
560	35 × 40	170	60	260	5.13	3.81	2.20	B43644B9567M0*#
680	30 × 55	140	45	220	6.42	4.78	2.75	B43644E9687M0*#
680	35 × 45	140	55	220	5.92	4.40	2.53	B43644A9687M0*#
820	35 × 50	130	45	190	6.69	4.99	2.86	B43644E9827M0*#

Composition of ordering code

* = Insulation feature

6 = PET insulation

 8 = PVC insulation with additional PET insulation
cap on terminal side

= Terminal style

0 = snap-in standard terminals (6.3 mm)

2 = snap-in 3 terminals (4.5 mm)

7 = snap-in short terminals (4.5 mm)

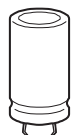

B43644

Very compact, long useful life – 105 °C

Technical data and ordering codes

C_R 100 Hz 20 °C μF	Case dimensions $d \times l$ mm	ESR_{typ} 100 Hz 20 °C $\text{m}\Omega$	ESR_{typ} 300 Hz 60 °C $\text{m}\Omega$	Z_{max} 10 kHz 20 °C $\text{m}\Omega$	$I_{\text{AC,max}}$ 100 Hz 60 °C A	$I_{\text{AC,max}}$ 100 Hz 85 °C A	$I_{\text{AC,R}}$ 100 Hz 105 °C A	Ordering code (composition see below)
$V_R = 450 \text{ V DC}$								
68	22 × 25	1430	360	2140	1.26	0.94	0.51	B43644A5686M0*#
82	22 × 25	1240	290	1900	1.46	1.09	0.59	B43644E5826M0*#
100	22 × 30	970	250	1460	1.70	1.26	0.69	B43644A5107M0*#
100	25 × 25	980	260	1470	1.67	1.24	0.67	B43644B5107M0*#
120	22 × 35	810	210	1220	1.96	1.45	0.79	B43644A5127M0*#
120	25 × 25	860	210	1300	1.91	1.43	0.77	B43644E5127M0*#
150	22 × 40	650	170	980	2.35	1.74	0.95	B43644A5157M0*#
150	25 × 30	680	170	1100	2.25	1.68	0.90	B43644E5157M0*#
150	30 × 25	670	190	1010	2.20	1.63	0.89	B43644C5157M0*#
180	22 × 45	540	140	810	2.74	2.02	1.10	B43644A5187M0*#
180	25 × 35	550	150	820	2.62	1.94	1.05	B43644B5187M0*#
180	30 × 25	590	160	890	2.49	1.86	1.00	B43644E5187M0*#
220	22 × 50	460	110	700	3.22	2.40	1.29	B43644E5227M0*#
220	25 × 40	470	110	710	3.04	2.27	1.22	B43644F5227M0*#
220	30 × 30	460	130	700	2.90	2.15	1.17	B43644B5227M0*#
220	35 × 25	470	150	720	2.80	2.08	1.13	B43644C5227M0*#
270	25 × 45	380	95	580	3.61	2.69	1.44	B43644E5277M0*#
270	30 × 35	370	110	570	3.38	2.51	1.36	B43644B5277M0*#
270	35 × 30	380	120	580	3.25	2.41	1.40	B43644C5277M0*#
330	25 × 55	310	75	470	4.26	3.18	1.71	B43644E5337M0*#
330	30 × 40	310	90	470	3.97	2.94	1.70	B43644A5337M0*#
330	35 × 30	330	100	520	3.66	2.73	1.57	B43644F5337M0*#
390	30 × 45	270	70	410	4.47	3.34	1.92	B43644E5397M0*#
390	35 × 35	270	90	420	4.21	3.12	1.80	B43644B5397M0*#
470	30 × 50	220	60	350	5.21	3.88	2.23	B43644E5477M0*#
470	35 × 40	230	75	350	4.84	3.59	2.07	B43644B5477M0*#
560	35 × 45	200	60	310	5.46	4.08	2.34	B43644E5567M0*#
680	35 × 55	160	50	240	6.47	4.81	2.77	B43644A5687M0*#

Composition of ordering code

* = Insulation feature

6 = PET insulation

8 = PVC insulation with additional PET insulation
cap on terminal side

= Terminal style

0 = snap-in standard terminals (6.3 mm)

2 = snap-in 3 terminals (4.5 mm)

7 = snap-in short terminals (4.5 mm)

Technical data and ordering codes

C_R 100 Hz 20 °C μF	Case dimensions $d \times l$ mm	ESR_{typ} 100 Hz 20 °C $\text{m}\Omega$	ESR_{typ} 300 Hz 60 °C $\text{m}\Omega$	Z_{max} 10 kHz 20 °C $\text{m}\Omega$	$I_{\text{AC,max}}$ 100 Hz 60 °C A	$I_{\text{AC,max}}$ 100 Hz 85 °C A	$I_{\text{AC,R}}$ 100 Hz 105 °C A	Ordering code (composition see below)
$V_R = 500 \text{ V DC}$								
47	22 × 25	1680	460	2400	0.99	0.88	0.42	B43644J6476M0*#
56	22 × 30	1400	380	2000	1.18	1.00	0.47	B43644J6566M0*#
68	22 × 30	1160	320	1660	1.43	1.14	0.54	B43644J6686M0*#
68	25 × 25	1170	330	1670	1.43	1.15	0.54	B43644K6686M0*#
82	22 × 35	960	260	1380	1.73	1.32	0.62	B43644J6826M0*#
82	25 × 30	960	270	1380	1.73	1.31	0.62	B43644K6826M0*#
100	22 × 40	790	220	1130	2.05	1.53	0.72	B43644J6107M0*#
100	25 × 35	790	220	1130	2.02	1.51	0.72	B43644K6107M0*#
100	30 × 25	800	240	1160	2.04	1.52	0.72	B43644L6107M0*#
120	22 × 45	660	180	940	2.37	1.77	0.84	B43644J6127M0*#
120	25 × 35	660	190	950	2.31	1.72	0.81	B43644K6127M0*#
120	30 × 30	670	190	960	2.31	1.73	0.82	B43644L6127M0*#
150	25 × 45	530	150	760	2.74	2.04	0.97	B43644J6157M0*#
150	30 × 30	540	160	780	2.68	1.99	0.94	B43644K6157M0*#
150	35 × 25	550	180	800	2.68	2.00	0.94	B43644L6157M0*#
180	25 × 50	440	120	630	3.15	2.35	1.11	B43644J6187M0*#
180	30 × 35	450	130	650	3.05	2.27	1.07	B43644K6187M0*#
180	35 × 30	460	140	660	3.05	2.27	1.15	B43644L6187M0*#
220	25 × 55	360	100	520	3.70	2.75	1.30	B43644J6227M0*#
220	30 × 40	370	110	530	3.53	2.63	1.33	B43644K6227M0*#
220	35 × 35	370	120	540	3.50	2.61	1.32	B43644L6227M0*#
270	30 × 50	300	90	430	4.13	3.08	1.56	B43644J6277M0*#
270	35 × 40	300	95	450	4.02	3.00	1.52	B43644K6277M0*#
330	30 × 55	250	75	360	4.81	3.58	1.81	B43644J6337M0*#
330	35 × 45	250	80	370	4.62	3.45	1.74	B43644K6337M0*#
390	35 × 50	210	70	310	5.20	3.88	1.96	B43644J6397M0*#
470	35 × 55	180	60	260	5.96	4.43	2.24	B43644J6477M0*#

Composition of ordering code

* = Insulation feature

6 = PET insulation

 8 = PVC insulation with additional PET insulation
cap on terminal side

= Terminal style

0 = snap-in standard terminals (6.3 mm)

2 = snap-in 3 terminals (4.5 mm)

7 = snap-in short terminals (4.5 mm)

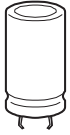

B43644

Very compact, long useful life – 105 °C

Useful life

For useful life calculations, please use our web-based "AlCap Useful Life Calculation Tool", which can be found on the Internet under the following link:

www.tdk-electronics.tdk.com/alcap

The AlCap Useful Life Calculation Tool provides calculations of useful life as well as additional data for selected capacitor types under operating conditions defined by the user.

In addition, it is possible to calculate useful life expectancies based on temperatures measured by the user in the application.

Frequency characteristics of ESR

Typical behavior

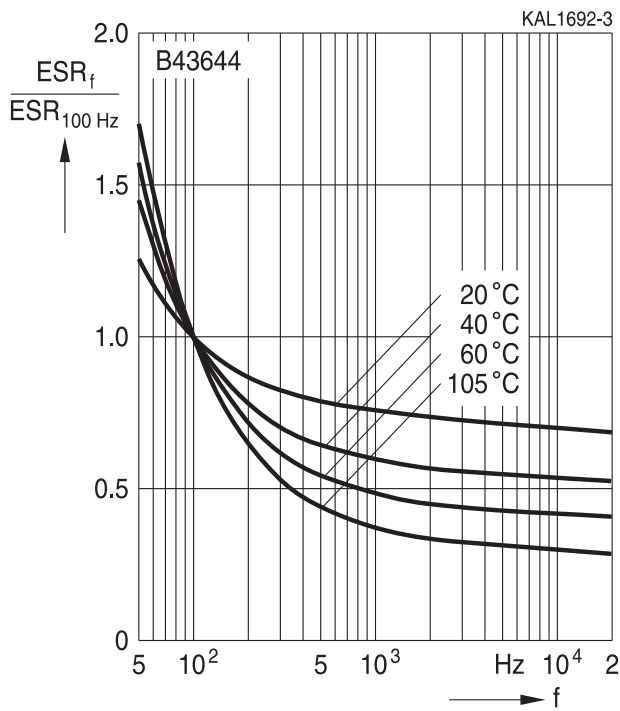

Impedance Z versus frequency f

Typical behavior at 20 °C

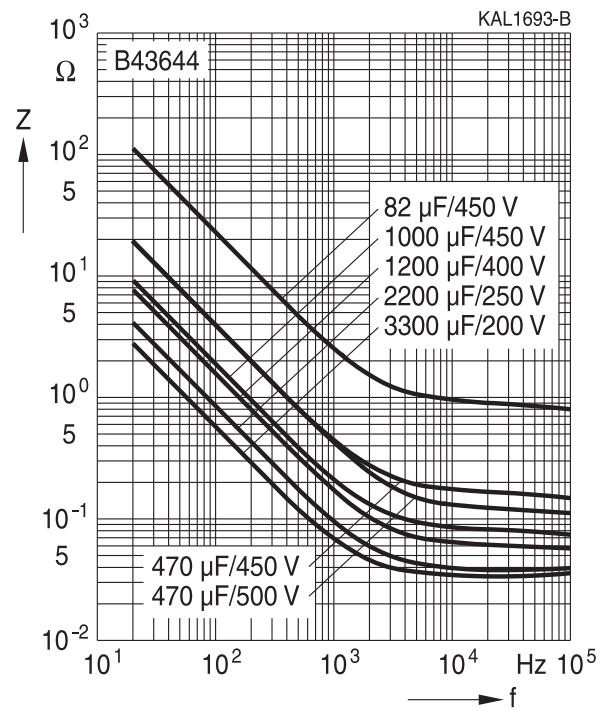



Cautions and warnings

Personal safety

The electrolytes used have been optimized both with a view to the intended application and with regard to health and environmental compatibility. They do not contain any solvents that are detrimental to health, e.g. dimethyl formamide (DMF) or dimethyl acetamide (DMAC). Furthermore, some of the high-voltage electrolytes used are self-extinguishing.

As far as possible, we do not use any dangerous chemicals or compounds to produce operating electrolytes, although in exceptional cases, such materials must be used in order to achieve specific physical and electrical properties because no alternative materials are currently known. We do, however, restrict the amount of dangerous materials used in our products to an absolute minimum.

Materials and chemicals used in our aluminum electrolytic capacitors are continuously adapted in compliance with the TDK Electronics Corporate Environmental Policy and the latest EU regulations and guidelines such as RoHS, REACH/SVHC, GADSL, and ELV.

MDS (Material Data Sheets) are available on our website for all types listed in the data book. MDS for customer specific capacitors are available upon request.

MSDS (Material Safety Data Sheets) are available for our electrolytes upon request.

Nevertheless, the following rules should be observed when handling aluminum electrolytic capacitors: No electrolyte should come into contact with eyes or skin. If electrolyte does come into contact with the skin, wash the affected areas immediately with running water. If the eyes are affected, rinse them for 10 minutes with plenty of water. If symptoms persist, seek medical treatment. Avoid inhaling electrolyte vapor or mists. Workplaces and other affected areas should be well ventilated. Clothing that has been contaminated by electrolyte must be changed and rinsed in water.

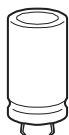

B43644

Very compact, long useful life – 105 °C

Product safety

The table below summarizes the safety instructions that must be observed without fail. A detailed description can be found in the relevant sections of separate file chapter "General technical information".

Topic	Safety information	Reference chapter "General technical information"
Polarity	Make sure that polar capacitors are connected with the right polarity.	1 "Basic construction of aluminum electrolytic capacitors"
Reverse voltage	Voltages of opposite polarity should be prevented by connecting a diode.	3.1.6 "Reverse voltage"
Mounting position of screw-terminal capacitors	Screw terminal capacitors must not be mounted with terminals facing down unless otherwise specified.	11.1. "Mounting positions of capacitors with screw terminals"
Robustness of terminals	The following maximum tightening torques must not be exceeded when connecting screw terminals: M5: 2.5 Nm M6: 4.0 Nm	11.2 "Mounting torques"
Mounting of single-ended capacitors	The internal structure of single-ended capacitors might be damaged if excessive force is applied to the lead wires. Avoid any compressive, tensile or flexural stress. Do not move the capacitor after soldering to PC board. Do not pick up the PC board by the soldered capacitor. Do not insert the capacitor on the PC board with a hole space different to the lead space specified.	11.3 "Mounting considerations for single-ended capacitors"
Soldering	Do not exceed the specified time or temperature limits during soldering.	11.5 "Soldering"
Soldering, cleaning agents	Do not allow halogenated hydrocarbons to come into contact with aluminum electrolytic capacitors.	11.6 "Cleaning agents"
Upper category temperature	Do not exceed the upper category temperature.	7.2 "Maximum permissible operating temperature"
Passive flammability	Avoid external energy, e.g. fire.	8.1 "Passive flammability"



Topic	Safety information	Reference chapter "General technical information"
Active flammability	Avoid overload of the capacitors.	8.2 "Active flammability"
Maintenance	Make periodic inspections of the capacitors. Before the inspection, make sure that the power supply is turned off and carefully discharge the capacitors. Do not apply excessive mechanical stress to the capacitor terminals when mounting.	10 "Maintenance"
Storage	Do not store capacitors at high temperatures or high humidity. Capacitors should be stored at +5 to +35 °C and a relative humidity of ≤ 75%.	7.3 "Shelf life and storage conditions"
		Reference chapter "Capacitors with screw terminals"
Breakdown strength of insulating sleeves	Do not damage the insulating sleeve, especially when ring clips are used for mounting.	"Screw terminals – accessories"

Display of ordering codes for TDK Electronics products

The ordering code for one and the same product can be represented differently in data sheets, data books, other publications, on the company website, or in order-related documents such as shipping notes, order confirmations and product labels. The varying representations of the ordering codes are due to different processes employed and do not affect the specifications of the respective products.

Detailed information can be found on the Internet under www.tdk-electronics.tdk.com/orderingcodes.

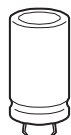

B43644

Very compact, long useful life – 105 °C

Symbols and terms

Symbol	English	German
C	Capacitance	Kapazität
C_R	Rated capacitance	Nennkapazität
C_S	Series capacitance	Serienkapazität
$C_{S,T}$	Series capacitance at temperature T	Serienkapazität bei Temperatur T
C_f	Capacitance at frequency f	Kapazität bei Frequenz f
d	Case diameter, nominal dimension	Gehäusedurchmesser, Nennmaß
d_{max}	Maximum case diameter	Maximaler Gehäusedurchmesser
ESL	Self-inductance	Eigeninduktivität
ESR	Equivalent series resistance	Ersatzserienwiderstand
ESR_f	Equivalent series resistance at frequency f	Ersatzserienwiderstand bei Frequenz f
ESR_T	Equivalent series resistance at temperature T	Ersatzserienwiderstand bei Temperatur T
f	Frequency	Frequenz
I	Current	Strom
I_{AC}	Alternating current (ripple current)	Wechselstrom
$I_{AC,RMS}$	Root-mean-square value of alternating current	Wechselstrom, Effektivwert
$I_{AC,f}$	Ripple current at frequency f	Wechselstrom bei Frequenz f
$I_{AC,max}$	Maximum permissible ripple current	Maximal zulässiger Wechselstrom
$I_{AC,R}$	Rated ripple current	Nennwechselstrom
I_{leak}	Leakage current	Reststrom
$I_{leak,op}$	Operating leakage current	Betriebsreststrom
l	Case length, nominal dimension	Gehäuselänge, Nennmaß
l_{max}	Maximum case length (without terminals and mounting stud)	Maximale Gehäuselänge (ohne Anschlüsse und Gewindebolzen)
R	Resistance	Widerstand
R_{ins}	Insulation resistance	Isolationswiderstand
R_{symm}	Balancing resistance	Symmetrierwiderstand
T	Temperature	Temperatur
ΔT	Temperature difference	Temperaturdifferenz
T_A	Ambient temperature	Umgebungstemperatur
T_C	Case temperature	Gehäusetemperatur
T_B	Capacitor base temperature	Temperatur des Gehäusebodens
t	Time	Zeit
Δt	Period	Zeitraum
t_b	Service life (operating hours)	Brauchbarkeitsdauer (Betriebszeit)



Symbol	English	German
V	Voltage	Spannung
V _F	Forming voltage	Formierspannung
V _{op}	Operating voltage	Betriebsspannung
V _R	Rated voltage, DC voltage	Nennspannung, Gleichspannung
V _S	Surge voltage	Spitzenspannung
X _C	Capacitive reactance	Kapazitiver Blindwiderstand
X _L	Inductive reactance	Induktiver Blindwiderstand
Z	Impedance	Scheinwiderstand
Z _T	Impedance at temperature T	Scheinwiderstand bei Temperatur T
tan δ	Dissipation factor	Verlustfaktor
λ	Failure rate	Ausfallrate
ε ₀	Absolute permittivity	Elektrische Feldkonstante
ε _r	Relative permittivity	Dielektrizitätszahl
ω	Angular velocity; 2 · π · f	Kreisfrequenz; 2 · π · f

Note

All dimensions are given in mm.

Important notes

The following applies to all products named in this publication:

1. Some parts of this publication contain **statements about the suitability of our products for certain areas of application**. These statements are based on our knowledge of typical requirements that are often placed on our products in the areas of application concerned. We nevertheless expressly point out **that such statements cannot be regarded as binding statements about the suitability of our products for a particular customer application**. As a rule, we are either unfamiliar with individual customer applications or less familiar with them than the customers themselves. For these reasons, it is always ultimately incumbent on the customer to check and decide whether a product with the properties described in the product specification is suitable for use in a particular customer application.
2. We also point out that **in individual cases, a malfunction of electronic components or failure before the end of their usual service life cannot be completely ruled out in the current state of the art, even if they are operated as specified**. In customer applications requiring a very high level of operational safety and especially in customer applications in which the malfunction or failure of an electronic component could endanger human life or health (e.g. in accident prevention or life-saving systems), it must therefore be ensured by means of suitable design of the customer application or other action taken by the customer (e.g. installation of protective circuitry or redundancy) that no injury or damage is sustained by third parties in the event of malfunction or failure of an electronic component.
3. **The warnings, cautions and product-specific notes must be observed.**
4. In order to satisfy certain technical requirements, **some of the products described in this publication may contain substances subject to restrictions in certain jurisdictions (e.g. because they are classed as hazardous)**. Useful information on this will be found in our Material Data Sheets on the Internet (www.tdk-electronics.tdk.com/material). Should you have any more detailed questions, please contact our sales offices.
5. We constantly strive to improve our products. Consequently, **the products described in this publication may change from time to time**. The same is true of the corresponding product specifications. Please check therefore to what extent product descriptions and specifications contained in this publication are still applicable before or when you place an order. We also **reserve the right to discontinue production and delivery of products**. Consequently, we cannot guarantee that all products named in this publication will always be available. The aforementioned does not apply in the case of individual agreements deviating from the foregoing for customer-specific products.
6. Unless otherwise agreed in individual contracts, **all orders are subject to our General Terms and Conditions of Supply**.



Important notes

7. **Our manufacturing sites serving the automotive business apply the IATF 16949 standard.**
The IATF certifications confirm our compliance with requirements regarding the quality management system in the automotive industry. Referring to customer requirements and customer specific requirements (“CSR”) TDK always has and will continue to have the policy of respecting individual agreements. Even if IATF 16949 may appear to support the acceptance of unilateral requirements, we hereby like to emphasize that **only requirements mutually agreed upon can and will be implemented in our Quality Management System.** For clarification purposes we like to point out that obligations from IATF 16949 shall only become legally binding if individually agreed upon.
8. The trade names EPCOS, CarXield, CeraCharge, CeraDiode, CeraLink, CeraPad, CeraPlas, CSMP, CTVS, DeltaCap, DigiSiMic, ExoCore, FilterCap, FormFit, InsuGate, LeaXield, MiniBlue, MiniCell, MKD, MKK, ModCap, MotorCap, PCC, PhaseCap, PhaseCube, PhaseMod, PhiCap, PowerHap, PQSine, PQvar, SIFERRIT, SIFI, SIKOREL, SilverCap, SIMDAD, SiMic, SIMID, SineFormer, SIOV, ThermoFuse, WindCap, XieldCap are **trademarks registered or pending** in Europe and in other countries. Further information will be found on the Internet at www.tdk-electronics.tdk.com/trademarks.

Release 2022-07

Looking for pricing, stock, or lifecycle information?

Click below to explore more details on WIN SOURCE:

-  [View B43644J6477M060 on WIN SOURCE](#)
-  [EPCOS \(TDK\) Information](#)

Optimize Your Supply Chain with WIN SOURCE Solutions

-  Global Sourcing Solution
-  Obsolete Management
-  Cost Control Management
-  Shortage Management
-  Alternative Solution
-  Excess Inventory Management