



Aluminum electrolytic capacitors

Snap-in capacitors

Series/Type: B43544

Date: December 2019

Long-life grade capacitors

Applications

- Servo drives
- Frequency converters
- Solar inverters
- Uninterruptible power supplies
- Professional power supplies
- Medical appliances
- Not for automotive applications unless otherwise specified



Features

- Very high ripple current capability
- Improved charge/discharge robustness
- Base cooling available upon request for case sizes with diameters of 30 to 35 mm and lengths of 35 to 55 mm
- Rated voltages up to 550 V DC
- Very high CV product, compact
- High reliability
- Extremely improved performance at high frequencies
- Very low ESR at operating conditions above 50 °C
- Optimized internal thermal resistance
- Capacitors with all insulation versions pass the needle flame test according to IEC 60695-11-5 for all flame exposure times up to 120 s
- RoHS-compatible

Construction

- Rapid charge/discharge-proof, polar
- Aluminum case, fully insulated with PET
- Version with PVC insulation and additional PET insulation cap on terminal side available for insulating the capacitor from the PCB
- Version with PVC insulation available upon request
- Snap-in solder pins to hold component in place on PC-board
- Minus pole marking on case surface
- Minus pole not insulated from case
- Overload protection by safety vent on the case wall

Terminals

- Standard version with 2 terminals,
2 lengths available: 6.3 and 4.5 mm
- 3 terminals to ensure correct insertion: length 4.5 mm

Specifications and characteristics in brief

Rated voltage V_R Surge voltage V_S	200 ... 550 V DC 1.15 · V_R (for $V_R \leq 250$ V DC) 1.10 · V_R (for $V_R \geq 400$ V DC)		
Rated capacitance C_R Capacitance tolerance	47 ... 2700 μ F $\pm 20\% \triangleq M$		
Dissipation factor $\tan \delta$ (20 °C, 120 Hz)	$V_R \leq 400$ V DC: $\tan \delta \leq 0.15$ $V_R \geq 450$ V DC: $\tan \delta \leq 0.20$		
Leakage current I_{leak} (5 min, 20 °C)	$I_{leak} \leq 0.3 \mu A \cdot \left(\frac{C_R}{\mu F} \cdot \frac{V_R}{V} \right)^{0.7} + 4 \mu A$		
Self-inductance ESL	Approx. 20 nH		
Useful life ¹⁾ 105 °C; V_R ; $I_{AC,R}$	> 3000 h	Requirements: $ \Delta C/C \leq 20\%$ of initial value $\tan \delta \leq 2$ times initial specified limit $I_{leak} \leq$ initial specified limit	
Voltage endurance test 105 °C; V_R	2000 h	Post test requirements: $ \Delta C/C \leq 10\%$ of initial value $\tan \delta \leq 1.3$ times initial specified limit $I_{leak} \leq$ initial specified limit	
Rapid charge/discharge ≤ 35 °C; $\Delta V \leq 150$ V; 6 Hz	> 50 million cycles	Requirements: $ \Delta C/C \leq 20\%$ of initial value $\tan \delta \leq 2$ times initial specified limit $I_{leak} \leq$ initial specified limit	
	$V_R = 400 \dots 450$ V; $l \leq 55$ mm		
Vibration resistance test	To IEC 60068-2-6, test Fc: Frequency range 10 Hz ... 55 Hz, displacement amplitude 0.35 mm, acceleration max. 5 g, duration 3 × 2 h. Capacitor mounted by its body which is rigidly clamped to the work surface.		
Characteristics at low temperature	Max. impedance ratio at 100 Hz	V_R	≤ 400 V 450 V 500 ... 550 V
		$Z_{-25\text{ °C}} / Z_{20\text{ °C}}$	3 5 7
		$Z_{-40\text{ °C}} / Z_{20\text{ °C}}$	7 14 14
IEC climatic category	To IEC 60068-1: $V_R \leq 400$ V DC: 40/105/56 (–40 °C/+105 °C/56 days damp heat test) $V_R \geq 450$ V DC: 25/105/56 (–25 °C/+105 °C/56 days damp heat test) The capacitors can be operated in the temperature range of –40 °C to +105 °C but the impedance at –40 °C must be taken into consideration.		
Sectional specification	IEC 60384-4		

1) Refer to chapter "General technical information, 5 Useful life" on how to interpret useful life.

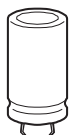

B43544

Very high ripple current, high voltage – 105 °C

Dimensional drawings

Snap-in capacitors with standard insulation (PET)

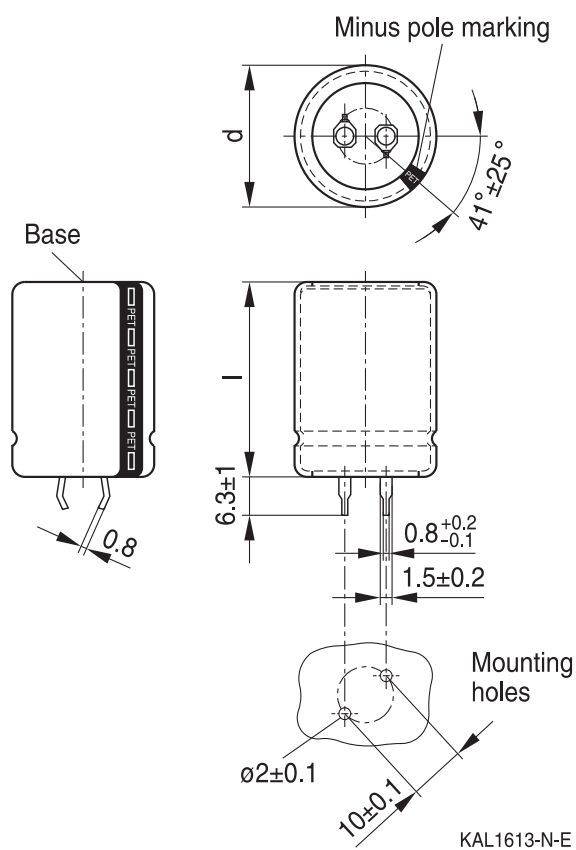

Dimensions (mm)		Approx. weight (g)	Packing units (pcs.)
d +1	l ±2		
25	25	13	130
25	30	17	130
25	35	19	130
25	40	22	130
25	45	25	130
25	50	29	130
25	55	32	130

Snap-in terminals, length (6.3 ± 1) mm.
 Also available in a shorter version with a length of $(4.5 - 1)$ mm.

Insulation is marked with "PET" on the sleeve.
 Safety vent on the case wall.

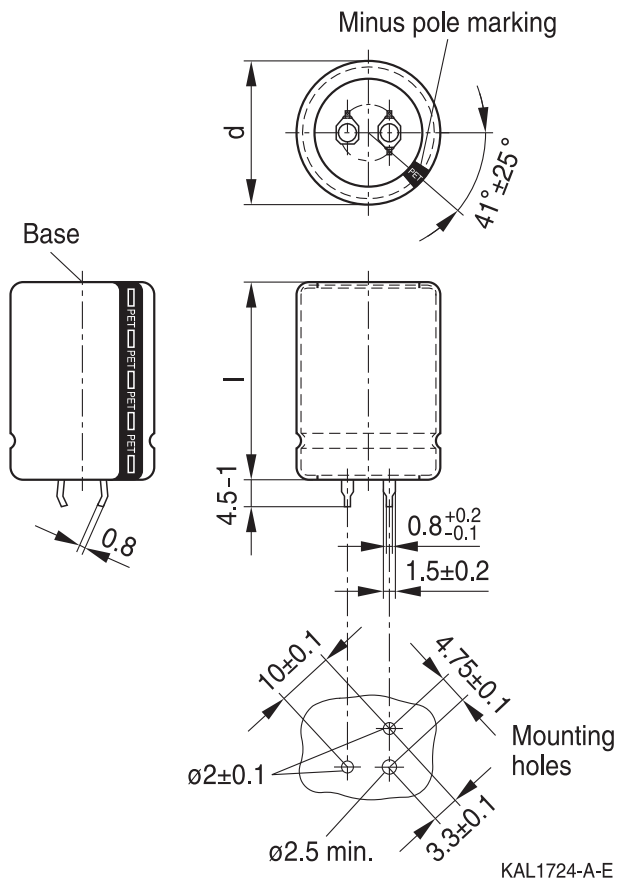
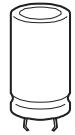

Snap-in capacitors are also available with 3 terminals (length (4.5 – 1) mm). Insulation is marked with "PET" on the sleeve. Safety vent on the case wall.

Dimensions (mm)		Approx. weight (g)	Packing units (pcs.)
d +1	l ±2		
30	25	17	80
30	30	23	80
30	35	29	80
30	40	36	80
30	45	41	80
30	50	46	80
30	55	53	80
30	60	58	60
30	65	64	60
30	70	69	60
30	75	74	60
30	80	80	60
35	25	22	60
35	30	29	60
35	35	36	60
35	40	41	60
35	45	56	60
35	50	70	60
35	55	81	60
35	60	90	36
35	65	102	36
35	70	115	36
35	75	128	36
35	80	142	36

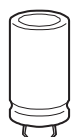

B43544

Very high ripple current, high voltage – 105 °C

Snap-in capacitors with PVC insulation and PET insulation cap on terminal side

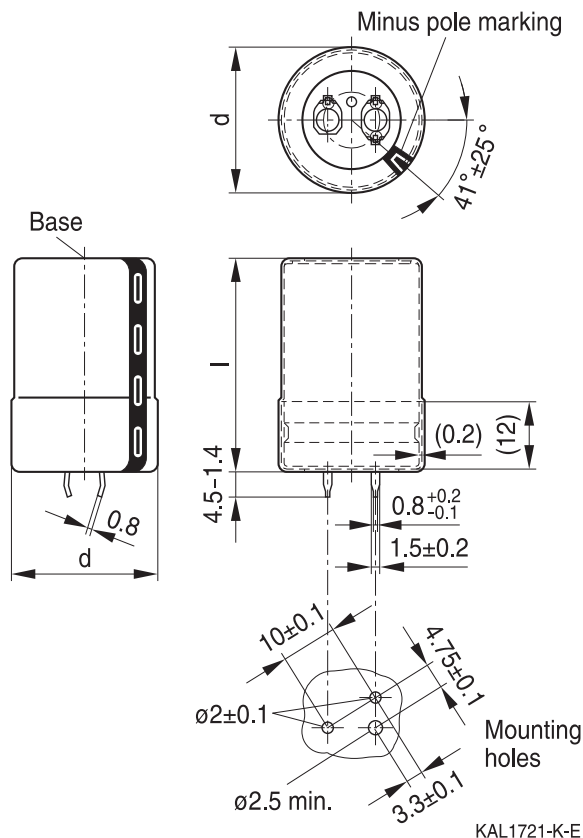
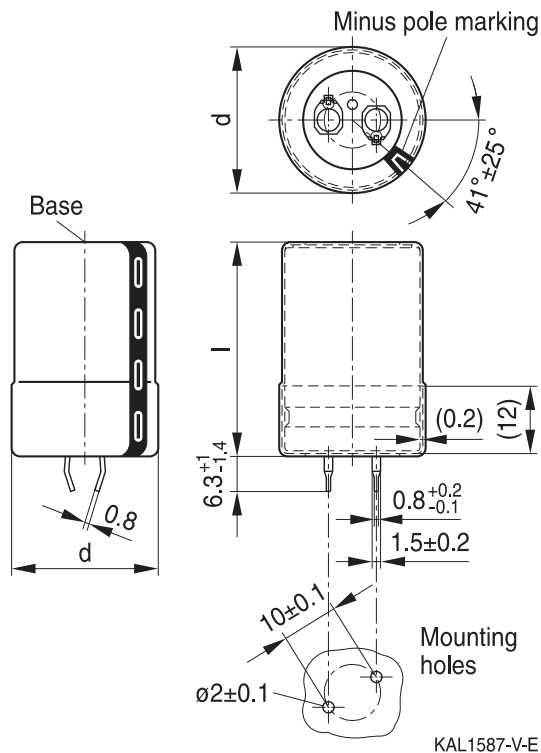

Snap-in terminals, length (6.3 +1/-1.4) mm. Also available in a shorter version with a length of (4.5 -1.4) mm. PET insulation cap is positioned under the insulation sleeve. Safety vent on the case wall.

Snap-in capacitors are also available with 3 terminals (length (4.5 -1.4) mm). PET insulation cap is positioned under the insulation sleeve. Safety vent on the case wall.

Dimensions (mm)		Approx. weight (g)	Packing units (pcs.)
d +1.4	l +2.2/-2		
25	25	13	115
25	30	17	115
25	35	19	115
25	40	22	115
25	45	25	115
25	50	29	115
25	55	32	115

Dimensions (mm)		Approx. weight (g)	Packing units (pcs.)
d +1.4	l +2.2/-2		
30	25	17	80
30	30	23	80
30	35	29	80
30	40	36	80
30	45	41	80
30	50	46	80
30	55	53	80
35	25	22	60
35	30	29	60
35	35	36	60
35	40	41	60
35	45	56	60
35	50	70	60
35	55	81	60



Packing of snap-in capacitors



For ecological reasons the packing is pure cardboard.

Ordering codes for terminal styles and insulation features

Identification in 3rd block of ordering code

Snap-in capacitors

Terminal version	Insulation version	
	PET	PVC plus PET cap
Standard terminals 6.3 mm	M060	M080
Short terminals 4.5 mm	M067	M087
3 terminals 4.5 mm	M062	M082

Ordering examples:

- B43544E5107M067 } snap-in capacitor with short terminals and PET insulation
- B43544E5107M062 } snap-in capacitor with 3 terminals and PET insulation
- B43544E5107M080 } snap-in capacitor with standard terminals and PVC insulation with additional PET insulation cap on terminal side

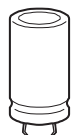

B43544

Very high ripple current, high voltage – 105 °C

Overview of available types

The capacitance and voltage ratings listed below are available in different case sizes upon request. Other voltage and capacitance ratings are also available upon request.

V_R (V DC)	200	250	400	450	500	550
	Case dimensions $d \times l$ (mm)					
C_R (μ F)						
47						25 × 25
56						25 × 30
68					25 × 25	25 × 35 30 × 25
82				25 × 25	25 × 30	25 × 35 30 × 30
100				25 × 30	25 × 35 30 × 25	25 × 40 30 × 35 35 × 25
120			25 × 25	25 × 30 30 × 25	25 × 35 30 × 30	25 × 50 30 × 35 35 × 30
150			25 × 30	25 × 35 30 × 30	25 × 45 30 × 35 35 × 25	25 × 55 30 × 45 35 × 35
180			25 × 35 30 × 25	25 × 40 30 × 30 35 × 25	25 × 50 30 × 35 35 × 30	30 × 50 35 × 40
220			25 × 35 30 × 30	25 × 45 30 × 35 35 × 30	25 × 55 30 × 40 35 × 35	30 × 55 35 × 45
270			25 × 45 30 × 35 35 × 25	25 × 50 30 × 40 35 × 30	30 × 50 35 × 40	35 × 50
330		25 × 25	25 × 50 30 × 35 35 × 30	30 × 45 35 × 35	30 × 55 35 × 45	
390	25 × 25	25 × 30	25 × 55 30 × 40 35 × 35	30 × 50 35 × 40	35 × 50	
470	25 × 30	25 × 30 30 × 25	30 × 45 35 × 35	30 × 60 35 × 45	35 × 55	
560	25 × 30	25 × 35 30 × 30	30 × 55 35 × 40	30 × 70 35 × 50		



Overview of available types

The capacitance and voltage ratings listed below are available in different case sizes upon request. Other voltage and capacitance ratings are also available upon request.

V_R (V DC)	200	250	400	450	500	550
	Case dimensions $d \times l$ (mm)					
C_R (μ F)						
680	25 × 35 30 × 25	25 × 40 30 × 30 35 × 25	30 × 70 35 × 50	35 × 65		
820	25 × 40 30 × 30 35 × 25	25 × 45 30 × 35 35 × 30	30 × 80 35 × 55	35 × 75		
1000	25 × 45 30 × 35 35 × 30	25 × 55 30 × 40 35 × 30	35 × 70			
1200	25 × 50 30 × 40 35 × 30	30 × 45 35 × 35	35 × 80			
1500	30 × 45 35 × 35	30 × 55 35 × 40				
1800	30 × 50 35 × 40	35 × 50				
2200	30 × 55 35 × 45	35 × 55				
2700	35 × 50					

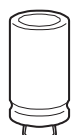

B43544

Very high ripple current, high voltage – 105 °C

Technical data and ordering codes

C_R 100 Hz 20 °C μF	Case dimensions $d \times l$ mm	ESR_{typ} 100 Hz 20 °C $\text{m}\Omega$	ESR_{typ} 300 Hz 60 °C $\text{m}\Omega$	Z_{max} 10 kHz 20 °C $\text{m}\Omega$	$I_{\text{AC,max}}$ 100 Hz 60 °C A	$I_{\text{AC,max}}$ 100 Hz 85 °C A	$I_{\text{AC,R}}$ 100 Hz 105 °C A	Ordering code (composition see below)
$V_R = 200 \text{ V DC}$								
390	25 × 25	220	80	320	3.42	2.52	1.31	B43544A2397M0*#
470	25 × 30	180	65	260	3.96	2.92	1.52	B43544A2477M0*#
560	25 × 30	160	60	230	4.30	3.17	1.64	B43544A2567M0*#
680	25 × 35	130	50	190	4.96	3.66	1.90	B43544A2687M0*#
680	30 × 25	120	45	180	5.35	3.94	2.04	B43544B2687M0*#
820	25 × 40	110	40	160	5.67	4.19	2.17	B43544A2827M0*#
820	30 × 30	100	34	150	6.15	4.53	2.35	B43544B2827M0*#
820	35 × 25	110	40	160	6.13	4.52	2.34	B43544C2827M0*#
1000	25 × 45	90	34	130	6.50	4.80	2.49	B43544A2108M0*#
1000	30 × 35	85	28	120	7.07	5.21	2.71	B43544B2108M0*#
1000	35 × 30	85	32	130	7.12	5.25	2.88	B43544C2108M0*#
1200	25 × 50	75	30	110	7.37	5.45	2.82	B43544A2128M0*#
1200	30 × 40	70	24	100	8.05	5.93	3.26	B43544B2128M0*#
1200	35 × 30	75	30	110	7.67	5.66	3.09	B43544C2128M0*#
1500	30 × 45	55	20	80	9.36	6.90	3.78	B43544A2158M0*#
1500	35 × 35	60	24	90	8.91	6.58	3.60	B43544B2158M0*#
1800	30 × 50	45	17	70	10.6	7.84	4.30	B43544A2188M0*#
1800	35 × 40	50	20	75	10.1	7.46	4.08	B43544B2188M0*#
2200	30 × 55	40	15	60	12.2	9.01	4.93	B43544A2228M0*#
2200	35 × 45	40	17	60	11.5	8.49	4.64	B43544B2228M0*#
2700	35 × 50	34	15	55	13.1	9.68	5.29	B43544A2278M0*#

Composition of ordering code

* = Insulation feature

6 = PET insulation

8 = PVC insulation with additional PET insulation
cap on terminal side

= Terminal style

0 = snap-in standard terminals (6.3 mm)

2 = snap-in 3 terminals (4.5 mm)

7 = snap-in short terminals (4.5 mm)

Technical data and ordering codes

C_R 100 Hz 20 °C μF	Case dimensions $d \times l$ mm	ESR_{typ} 100 Hz 20 °C $\text{m}\Omega$	ESR_{typ} 300 Hz 60 °C $\text{m}\Omega$	Z_{max} 10 kHz 20 °C $\text{m}\Omega$	$I_{\text{AC,max}}$ 100 Hz 60 °C A	$I_{\text{AC,max}}$ 100 Hz 85 °C A	$I_{\text{AC,R}}$ 100 Hz 105 °C A	Ordering code (composition see below)
$V_R = 250 \text{ V DC}$								
330	25 × 25	220	85	310	3.29	2.43	1.26	B43544E2337M0*#
390	25 × 30	180	65	260	3.76	2.78	1.44	B43544E2397M0*#
470	25 × 30	160	60	220	4.12	3.04	1.57	B43544E2477M0*#
470	30 × 25	150	50	210	4.62	3.41	1.76	B43544F2477M0*#
560	25 × 35	130	50	190	4.72	3.49	1.80	B43544E2567M0*#
560	30 × 30	120	40	170	5.25	3.88	2.01	B43544F2567M0*#
680	25 × 40	110	40	150	5.42	4.01	2.07	B43544E2687M0*#
680	30 × 30	100	36	150	5.84	4.31	2.23	B43544F2687M0*#
680	35 × 25	110	40	150	5.81	4.29	2.22	B43544G2687M0*#
820	25 × 45	90	36	130	6.19	4.58	2.37	B43544E2827M0*#
820	30 × 35	85	30	120	6.67	4.93	2.55	B43544F2827M0*#
820	35 × 30	90	32	130	6.72	4.97	2.71	B43544G2827M0*#
1000	25 × 55	75	28	110	7.30	5.40	2.80	B43544E2108M0*#
1000	30 × 40	70	24	100	7.69	5.68	3.11	B43544F2108M0*#
1000	35 × 30	75	30	110	7.33	5.41	2.95	B43544G2108M0*#
1200	30 × 45	60	20	85	8.74	6.46	3.53	B43544E2128M0*#
1200	35 × 35	65	24	90	8.37	6.19	3.38	B43544F2128M0*#
1500	30 × 55	45	17	65	10.3	7.67	4.20	B43544E2158M0*#
1500	35 × 40	50	20	75	9.68	7.15	3.90	B43544F2158M0*#
1800	35 × 50	40	16	60	11.2	8.34	4.56	B43544E2188M0*#
2200	35 × 55	34	14	50	12.8	9.50	5.19	B43544E2228M0*#

Composition of ordering code

* = Insulation feature

6 = PET insulation

8 = PVC insulation with additional PET insulation
cap on terminal side

= Terminal style

0 = snap-in standard terminals (6.3 mm)

2 = snap-in 3 terminals (4.5 mm)

7 = snap-in short terminals (4.5 mm)

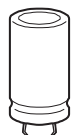

B43544

Very high ripple current, high voltage – 105 °C

Technical data and ordering codes

C_R 100 Hz 20 °C μF	Case dimensions $d \times l$ mm	ESR_{typ} 100 Hz 20 °C $\text{m}\Omega$	ESR_{typ} 300 Hz 60 °C $\text{m}\Omega$	Z_{max} 10 kHz 20 °C $\text{m}\Omega$	$I_{\text{AC,max}}$ 100 Hz 60 °C A	$I_{\text{AC,max}}$ 100 Hz 85 °C A	$I_{\text{AC,R}}$ 100 Hz 105 °C A	Ordering code (composition see below)
$V_R = 400 \text{ V DC}$								
120	25 × 25	580	180	820	2.31	1.77	1.01	B43544E9127M0*#
150	25 × 30	460	140	650	2.70	2.08	1.18	B43544E9157M0*#
180	25 × 35	380	110	540	3.07	2.36	1.35	B43544E9187M0*#
180	30 × 25	380	110	540	3.24	2.48	1.41	B43544F9187M0*#
220	25 × 35	320	100	450	3.48	2.67	1.52	B43544E9227M0*#
220	30 × 30	310	90	440	3.71	2.85	1.62	B43544F9227M0*#
270	25 × 45	260	75	370	4.11	3.16	1.80	B43544E9277M0*#
270	30 × 35	250	75	360	4.27	3.28	1.87	B43544F9277M0*#
270	35 × 25	250	75	360	4.43	3.40	1.93	B43544G9277M0*#
330	25 × 50	210	65	300	4.74	3.64	2.08	B43544E9337M0*#
330	30 × 35	210	60	300	4.84	3.71	2.11	B43544F9337M0*#
330	35 × 30	210	60	300	5.09	3.90	2.32	B43544G9337M0*#
390	25 × 55	180	55	260	5.38	4.13	2.36	B43544E9397M0*#
390	30 × 40	180	50	250	5.46	4.19	2.50	B43544F9397M0*#
390	35 × 35	170	50	250	5.69	4.37	2.60	B43544G9397M0*#
470	30 × 45	150	45	210	6.25	4.80	2.86	B43544E9477M0*#
470	35 × 35	140	45	210	6.40	4.91	2.92	B43544F9477M0*#
560	30 × 55	120	36	180	7.16	5.50	3.28	B43544E9567M0*#
560	35 × 40	120	36	180	7.23	5.55	3.30	B43544F9567M0*#
680	30 × 70	95	28	140	8.22	6.11	3.34	B43544F9687M0*#
680	35 × 50	100	30	150	8.35	6.41	3.82	B43544E9687M0*#
820	30 × 80	80	24	110	9.54	7.09	3.88	B43544F9827M0*#
820	35 × 55	85	24	120	9.55	7.33	4.37	B43544E9827M0*#
1000	35 × 70	65	20	100	10.6	7.91	4.33	B43544E9108M0*#
1200	35 × 80	55	18	80	12.2	9.10	4.98	B43544E9128M0*#

Composition of ordering code

* = Insulation feature

6 = PET insulation

8 = PVC insulation with additional PET insulation
cap on terminal side

= Terminal style

0 = snap-in standard terminals (6.3 mm)

2 = snap-in 3 terminals (4.5 mm)

7 = snap-in short terminals (4.5 mm)

Technical data and ordering codes

C_R 100 Hz 20 °C μF	Case dimensions $d \times l$ mm	ESR_{typ} 100 Hz 20 °C m Ω	ESR_{typ} 300 Hz 60 °C m Ω	Z_{max} 10 kHz 20 °C m Ω	$I_{\text{AC,max}}$ 100 Hz 60 °C A	$I_{\text{AC,max}}$ 100 Hz 85 °C A	$I_{\text{AC,R}}$ 100 Hz 105 °C A	Ordering code (composition see below)
$V_R = 450 \text{ V DC}$								
82	25 × 25	1230	310	1890	1.73	1.39	0.77	B43544E5826M0*#
100	25 × 30	1000	250	1550	2.08	1.60	0.89	B43544E5107M0*#
120	25 × 30	840	220	1300	2.33	1.79	0.99	B43544E5127M0*#
120	30 × 25	830	210	1280	2.49	1.91	1.06	B43544F5127M0*#
150	25 × 35	670	170	1040	2.72	2.09	1.16	B43544E5157M0*#
150	30 × 30	670	170	1030	2.88	2.22	1.23	B43544F5157M0*#
180	25 × 40	560	140	870	3.11	2.39	1.32	B43544E5187M0*#
180	30 × 30	560	140	860	3.23	2.48	1.37	B43544F5187M0*#
180	35 × 25	560	140	860	3.41	2.62	1.45	B43544G5187M0*#
220	25 × 45	460	120	710	3.59	2.76	1.53	B43544E5227M0*#
220	30 × 35	460	120	700	3.71	2.85	1.57	B43544F5227M0*#
220	35 × 30	460	110	700	3.90	2.99	1.71	B43544G5227M0*#
270	25 × 50	380	100	580	4.19	3.21	1.78	B43544E5277M0*#
270	30 × 40	370	95	570	4.28	3.28	1.87	B43544F5277M0*#
270	35 × 30	370	95	570	4.42	3.39	1.93	B43544G5277M0*#
330	30 × 45	300	75	470	4.93	3.78	2.16	B43544E5337M0*#
330	35 × 35	300	75	470	5.07	3.89	2.21	B43544F5337M0*#
390	30 × 50	260	65	400	5.57	4.28	2.44	B43544E5397M0*#
390	35 × 40	260	65	400	5.68	4.36	2.49	B43544F5397M0*#
470	30 × 60	200	50	310	6.24	4.63	2.53	B43544F5477M0*#
470	35 × 45	210	55	330	6.47	4.97	2.83	B43544E5477M0*#
560	30 × 70	170	45	260	7.16	5.32	2.91	B43544F5567M0*#
560	35 × 50	180	45	280	7.34	5.63	3.21	B43544E5567M0*#
680	35 × 65	140	38	220	8.10	6.02	3.29	B43544E5687M0*#
820	35 × 75	120	32	180	9.34	6.94	3.80	B43544E5827M0*#

Composition of ordering code

* = Insulation feature

6 = PET insulation

 8 = PVC insulation with additional PET insulation
cap on terminal side

= Terminal style

0 = snap-in standard terminals (6.3 mm)

2 = snap-in 3 terminals (4.5 mm)

7 = snap-in short terminals (4.5 mm)

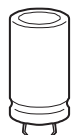

B43544

Very high ripple current, high voltage – 105 °C

Technical data and ordering codes

C_R 100 Hz 20 °C μF	Case dimensions $d \times l$ mm	ESR_{typ} 100 Hz 20 °C $\text{m}\Omega$	ESR_{typ} 300 Hz 60 °C $\text{m}\Omega$	Z_{max} 10 kHz 20 °C $\text{m}\Omega$	$I_{\text{AC,max}}$ 100 Hz 60 °C A	$I_{\text{AC,max}}$ 100 Hz 85 °C A	$I_{\text{AC,R}}$ 100 Hz 105 °C A	Ordering code (composition see below)
$V_R = 500 \text{ V DC}$								
68	25 × 25	1220	330	1810	1.43	1.23	0.59	B43544B6686M0*#
82	25 × 30	1010	280	1500	1.73	1.40	0.67	B43544B6826M0*#
100	25 × 35	830	230	1230	2.11	1.61	0.77	B43544C6107M0*#
100	30 × 25	830	220	1230	2.11	1.68	0.80	B43544D6107M0*#
120	25 × 35	690	190	1030	2.42	1.80	0.86	B43544C6127M0*#
120	30 × 30	690	190	1020	2.53	1.91	0.91	B43544D6127M0*#
150	25 × 45	550	150	820	2.87	2.14	1.02	B43544A6157M0*#
150	30 × 35	550	150	820	2.97	2.21	1.06	B43544B6157M0*#
150	35 × 25	560	150	830	3.07	2.28	1.09	B43544C6157M0*#
180	25 × 50	460	130	690	3.27	2.44	1.17	B43544A6187M0*#
180	30 × 35	460	120	680	3.35	2.49	1.19	B43544B6187M0*#
180	35 × 30	460	130	690	3.47	2.58	1.31	B43544C6187M0*#
220	25 × 55	380	110	570	3.80	2.83	1.36	B43544A6227M0*#
220	30 × 40	380	100	560	3.85	2.86	1.45	B43544B6227M0*#
220	35 × 35	380	100	560	3.97	2.95	1.50	B43544C6227M0*#
270	30 × 50	310	85	460	4.47	3.33	1.69	B43544A6277M0*#
270	35 × 40	310	85	460	4.54	3.38	1.72	B43544B6277M0*#
330	30 × 55	250	70	380	5.18	3.85	1.96	B43544A6337M0*#
330	35 × 45	250	70	380	5.20	3.87	1.96	B43544B6337M0*#
390	35 × 50	210	60	320	5.84	4.35	2.21	B43544A6397M0*#
470	35 × 55	180	50	270	6.66	4.96	2.52	B43544A6477M0*#

Composition of ordering code

* = Insulation feature

6 = PET insulation

8 = PVC insulation with additional PET insulation
cap on terminal side

= Terminal style

0 = snap-in standard terminals (6.3 mm)

2 = snap-in 3 terminals (4.5 mm)

7 = snap-in short terminals (4.5 mm)

Technical data and ordering codes

C_R 100 Hz 20 °C μF	Case dimensions $d \times l$ mm	ESR_{typ} 100 Hz 20 °C $\text{m}\Omega$	ESR_{typ} 300 Hz 60 °C $\text{m}\Omega$	Z_{max} 10 kHz 20 °C $\text{m}\Omega$	$I_{\text{AC,max}}$ 100 Hz 60 °C A	$I_{\text{AC,max}}$ 100 Hz 85 °C A	$I_{\text{AC,R}}$ 100 Hz 105 °C A	Ordering code (composition see below)
$V_R = 550 \text{ V DC}$								
47	25 × 25	2470	600	3840	0.99	0.99	0.47	B43544B7476M0*#
56	25 × 30	2070	500	3220	1.18	1.12	0.54	B43544B7566M0*#
68	25 × 35	1700	410	2660	1.43	1.28	0.62	B43544C7686M0*#
68	30 × 25	1700	410	2660	1.43	1.35	0.65	B43544D7686M0*#
82	25 × 35	1420	340	2200	1.73	1.45	0.69	B43544C7826M0*#
82	30 × 30	1410	340	2200	1.73	1.53	0.73	B43544D7826M0*#
100	25 × 40	1160	280	1810	2.11	1.67	0.80	B43544D7107M0*#
100	30 × 35	1160	280	1810	2.11	1.75	0.84	B43544E7107M0*#
100	35 × 25	1160	280	1810	2.11	1.82	0.87	B43544F7107M0*#
120	25 × 50	970	230	1510	2.53	1.92	0.92	B43544D7127M0*#
120	30 × 35	970	230	1510	2.53	1.97	0.94	B43544E7127M0*#
120	35 × 30	970	230	1510	2.53	2.05	1.04	B43544F7127M0*#
150	25 × 55	770	190	1210	3.03	2.26	1.09	B43544A7157M0*#
150	30 × 45	770	190	1210	3.08	2.30	1.17	B43544B7157M0*#
150	35 × 35	770	190	1210	3.17	2.37	1.21	B43544C7157M0*#
180	30 × 50	640	150	1010	3.51	2.62	1.33	B43544A7187M0*#
180	35 × 40	650	160	1010	3.59	2.68	1.36	B43544B7187M0*#
220	30 × 55	530	130	830	4.05	3.02	1.54	B43544A7227M0*#
220	35 × 45	530	130	830	4.11	3.07	1.56	B43544B7227M0*#
270	35 × 50	430	110	680	4.73	3.53	1.79	B43544A7277M0*#

Composition of ordering code

* = Insulation feature

6 = PET insulation

8 = PVC insulation with additional PET insulation
cap on terminal side

= Terminal style

0 = snap-in standard terminals (6.3 mm)

2 = snap-in 3 terminals (4.5 mm)

7 = snap-in short terminals (4.5 mm)

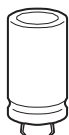

B43544

Very high ripple current, high voltage – 105 °C

Useful life¹⁾

For useful life calculations, please use our web-based "AlCap Useful Life Calculation Tool", which can be found on the Internet under the following link:

www.tdk-electronics.tdk.com/alcap

The AlCap Useful Life Calculation Tool provides calculations of useful life as well as additional data for selected capacitor types under operating conditions defined by the user.

In addition, it is possible to calculate useful life expectancies based on temperatures measured by the user in the application.

Frequency characteristics of ESR

Typical behavior

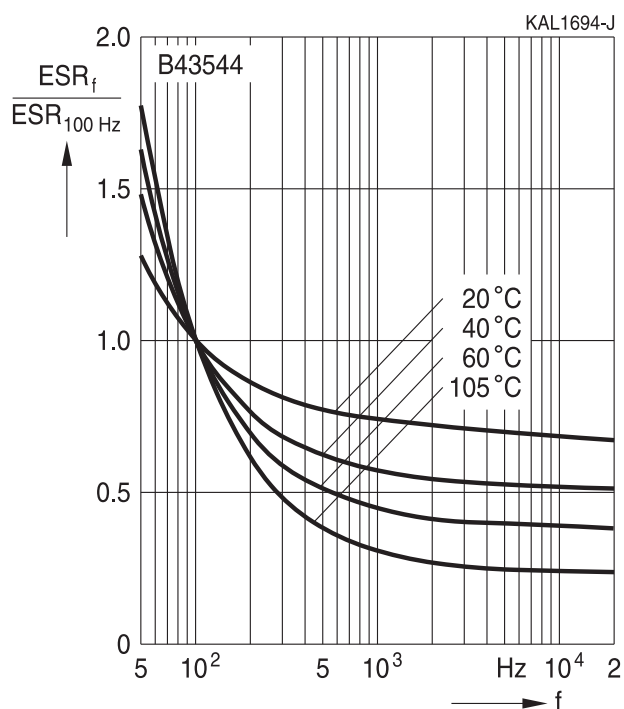

Impedance Z versus frequency f

Typical behavior at 20 °C

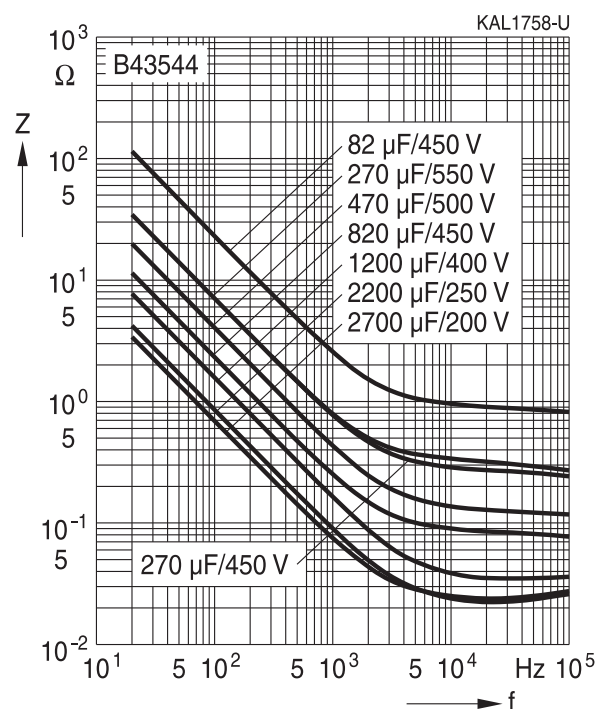

1) Refer to chapter "General technical information, 5 Useful life" on how to interpret useful life.



Cautions and warnings

Personal safety

The electrolytes used have been optimized both with a view to the intended application and with regard to health and environmental compatibility. They do not contain any solvents that are detrimental to health, e.g. dimethyl formamide (DMF) or dimethyl acetamide (DMAC). Furthermore, some of the high-voltage electrolytes used are self-extinguishing.

As far as possible, we do not use any dangerous chemicals or compounds to produce operating electrolytes, although in exceptional cases, such materials must be used in order to achieve specific physical and electrical properties because no alternative materials are currently known. We do, however, restrict the amount of dangerous materials used in our products to an absolute minimum.

Materials and chemicals used in our aluminum electrolytic capacitors are continuously adapted in compliance with the TDK Electronics Corporate Environmental Policy and the latest EU regulations and guidelines such as RoHS, REACH/SVHC, GADSL, and ELV.

MDS (Material Data Sheets) are available on our website for all types listed in the data book. MDS for customer specific capacitors are available upon request.

MSDS (Material Safety Data Sheets) are available for our electrolytes upon request.

Nevertheless, the following rules should be observed when handling aluminum electrolytic capacitors: No electrolyte should come into contact with eyes or skin. If electrolyte does come into contact with the skin, wash the affected areas immediately with running water. If the eyes are affected, rinse them for 10 minutes with plenty of water. If symptoms persist, seek medical treatment. Avoid inhaling electrolyte vapor or mists. Workplaces and other affected areas should be well ventilated. Clothing that has been contaminated by electrolyte must be changed and rinsed in water.

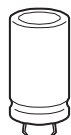

B43544

Very high ripple current, high voltage – 105 °C

Product safety

The table below summarizes the safety instructions that must be observed without fail. A detailed description can be found in the relevant sections of separate file chapter "General technical information".

Topic	Safety information	Reference chapter "General technical information"
Polarity	Make sure that polar capacitors are connected with the right polarity.	1 "Basic construction of aluminum electrolytic capacitors"
Reverse voltage	Voltages of opposite polarity should be prevented by connecting a diode.	3.1.6 "Reverse voltage"
Mounting position of screw-terminal capacitors	Screw terminal capacitors must not be mounted with terminals facing down unless otherwise specified.	11.1. "Mounting positions of capacitors with screw terminals"
Robustness of terminals	The following maximum tightening torques must not be exceeded when connecting screw terminals: M5: 2.5 Nm M6: 4.0 Nm	11.3 "Mounting torques"
Mounting of single-ended capacitors	The internal structure of single-ended capacitors might be damaged if excessive force is applied to the lead wires. Avoid any compressive, tensile or flexural stress. Do not move the capacitor after soldering to PC board. Do not pick up the PC board by the soldered capacitor. Do not insert the capacitor on the PC board with a hole space different to the lead space specified.	11.4 "Mounting considerations for single-ended capacitors"
Soldering	Do not exceed the specified time or temperature limits during soldering.	11.5 "Soldering"
Soldering, cleaning agents	Do not allow halogenated hydrocarbons to come into contact with aluminum electrolytic capacitors.	11.6 "Cleaning agents"
Upper category temperature	Do not exceed the upper category temperature.	7.2 "Maximum permissible operating temperature"
Passive flammability	Avoid external energy, e.g. fire.	8.1 "Passive flammability"



Topic	Safety information	Reference chapter "General technical information"
Active flammability	Avoid overload of the capacitors.	8.2 "Active flammability"
Maintenance	Make periodic inspections of the capacitors. Before the inspection, make sure that the power supply is turned off and carefully discharge the capacitors. Do not apply excessive mechanical stress to the capacitor terminals when mounting.	10 "Maintenance"
Storage	Do not store capacitors at high temperatures or high humidity. Capacitors should be stored at +5 to +35 °C and a relative humidity of ≤ 75%.	7.3 "Shelf life and storage conditions"
		Reference chapter "Capacitors with screw terminals"
Breakdown strength of insulating sleeves	Do not damage the insulating sleeve, especially when ring clips are used for mounting.	"Screw terminals – accessories"

Display of ordering codes for TDK Electronics products

The ordering code for one and the same product can be represented differently in data sheets, data books, other publications, on the company website, or in order-related documents such as shipping notes, order confirmations and product labels. The varying representations of the ordering codes are due to different processes employed and do not affect the specifications of the respective products.

Detailed information can be found on the Internet under www.tdk-electronics.tdk.com/orderingcodes.

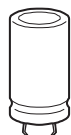

B43544

Very high ripple current, high voltage – 105 °C

Symbols and terms

Symbol	English	German
C	Capacitance	Kapazität
C_R	Rated capacitance	Nennkapazität
C_S	Series capacitance	Serienkapazität
$C_{S,T}$	Series capacitance at temperature T	Serienkapazität bei Temperatur T
C_f	Capacitance at frequency f	Kapazität bei Frequenz f
d	Case diameter, nominal dimension	Gehäusedurchmesser, Nennmaß
d_{max}	Maximum case diameter	Maximaler Gehäusedurchmesser
ESL	Self-inductance	Eigeninduktivität
ESR	Equivalent series resistance	Ersatzserienwiderstand
ESR_f	Equivalent series resistance at frequency f	Ersatzserienwiderstand bei Frequenz f
ESR_T	Equivalent series resistance at temperature T	Ersatzserienwiderstand bei Temperatur T
f	Frequency	Frequenz
I	Current	Strom
I_{AC}	Alternating current (ripple current)	Wechselstrom
$I_{AC,RMS}$	Root-mean-square value of alternating current	Wechselstrom, Effektivwert
$I_{AC,f}$	Ripple current at frequency f	Wechselstrom bei Frequenz f
$I_{AC,max}$	Maximum permissible ripple current	Maximal zulässiger Wechselstrom
$I_{AC,R}$	Rated ripple current	Nennwechselstrom
I_{leak}	Leakage current	Reststrom
$I_{leak,op}$	Operating leakage current	Betriebsreststrom
l	Case length, nominal dimension	Gehäuselänge, Nennmaß
l_{max}	Maximum case length (without terminals and mounting stud)	Maximale Gehäuselänge (ohne Anschlüsse und Gewindebolzen)
R	Resistance	Widerstand
R_{ins}	Insulation resistance	Isolationswiderstand
R_{symm}	Balancing resistance	Symmetrierwiderstand
T	Temperature	Temperatur
ΔT	Temperature difference	Temperaturdifferenz
T_A	Ambient temperature	Umgebungstemperatur
T_C	Case temperature	Gehäusetemperatur
T_B	Capacitor base temperature	Temperatur des Gehäusebodens
t	Time	Zeit
Δt	Period	Zeitraum
t_b	Service life (operating hours)	Brauchbarkeitsdauer (Betriebszeit)



Symbol	English	German
V	Voltage	Spannung
V _F	Forming voltage	Formierspannung
V _{op}	Operating voltage	Betriebsspannung
V _R	Rated voltage, DC voltage	Nennspannung, Gleichspannung
V _S	Surge voltage	Spitzenspannung
X _C	Capacitive reactance	Kapazitiver Blindwiderstand
X _L	Inductive reactance	Induktiver Blindwiderstand
Z	Impedance	Scheinwiderstand
Z _T	Impedance at temperature T	Scheinwiderstand bei Temperatur T
tan δ	Dissipation factor	Verlustfaktor
λ	Failure rate	Ausfallrate
ε ₀	Absolute permittivity	Elektrische Feldkonstante
ε _r	Relative permittivity	Dielektrizitätszahl
ω	Angular velocity; 2 · π · f	Kreisfrequenz; 2 · π · f

Note

All dimensions are given in mm.

Important notes

The following applies to all products named in this publication:

1. Some parts of this publication contain **statements about the suitability of our products for certain areas of application**. These statements are based on our knowledge of typical requirements that are often placed on our products in the areas of application concerned. We nevertheless expressly point out **that such statements cannot be regarded as binding statements about the suitability of our products for a particular customer application**. As a rule, we are either unfamiliar with individual customer applications or less familiar with them than the customers themselves. For these reasons, it is always ultimately incumbent on the customer to check and decide whether a product with the properties described in the product specification is suitable for use in a particular customer application.
2. We also point out that **in individual cases, a malfunction of electronic components or failure before the end of their usual service life cannot be completely ruled out in the current state of the art, even if they are operated as specified**. In customer applications requiring a very high level of operational safety and especially in customer applications in which the malfunction or failure of an electronic component could endanger human life or health (e.g. in accident prevention or lifesaving systems), it must therefore be ensured by means of suitable design of the customer application or other action taken by the customer (e.g. installation of protective circuitry or redundancy) that no injury or damage is sustained by third parties in the event of malfunction or failure of an electronic component.
3. **The warnings, cautions and product-specific notes must be observed.**
4. In order to satisfy certain technical requirements, **some of the products described in this publication may contain substances subject to restrictions in certain jurisdictions (e.g. because they are classed as hazardous)**. Useful information on this will be found in our Material Data Sheets on the Internet (www.tdk-electronics.tdk.com/material). Should you have any more detailed questions, please contact our sales offices.
5. We constantly strive to improve our products. Consequently, **the products described in this publication may change from time to time**. The same is true of the corresponding product specifications. Please check therefore to what extent product descriptions and specifications contained in this publication are still applicable before or when you place an order. We also **reserve the right to discontinue production and delivery of products**. Consequently, we cannot guarantee that all products named in this publication will always be available. The aforementioned does not apply in the case of individual agreements deviating from the foregoing for customer-specific products.
6. Unless otherwise agreed in individual contracts, **all orders are subject to our General Terms and Conditions of Supply**.



Important notes

7. **Our manufacturing sites serving the automotive business apply the IATF 16949 standard.** The IATF certifications confirm our compliance with requirements regarding the quality management system in the automotive industry. Referring to customer requirements and customer specific requirements (“CSR”) TDK always has and will continue to have the policy of respecting individual agreements. Even if IATF 16949 may appear to support the acceptance of unilateral requirements, we hereby like to emphasize that **only requirements mutually agreed upon can and will be implemented in our Quality Management System.** For clarification purposes we like to point out that obligations from IATF 16949 shall only become legally binding if individually agreed upon.
8. The trade names EPCOS, CeraCharge, CeraDiode, CeraLink, CeraPad, CeraPlas, CSMP, CTVS, DeltaCap, DigiSiMic, ExoCore, FilterCap, FormFit, LeaXield, MiniBlue, MiniCell, MKD, MKK, MotorCap, PCC, PhaseCap, PhaseCube, PhaseMod, PhiCap, PowerHap, PQSine, PQvar, SIFERRIT, SIFI, SIKOREL, SilverCap, SIMDAD, SiMic, SIMID, SineFormer, SIOV, ThermoFuse, WindCap are **trademarks registered or pending** in Europe and in other countries. Further information will be found on the Internet at www.tdk-electronics.tdk.com/trademarks.

Release 2018-10

Looking for pricing, stock, or lifecycle information?

Click below to explore more details on WIN SOURCE:

-  [View B43544E2397M62 on WIN SOURCE](#)
-  [EPCOS \(TDK\) Information](#)

Optimize Your Supply Chain with WIN SOURCE Solutions

-  Global Sourcing Solution
-  Obsolete Management
-  Cost Control Management
-  Shortage Management
-  Alternative Solution
-  Excess Inventory Management