



**THE DATASHEET OF
EZJ-ZSV270DAK**



To Digi-Key

Issue No. : EZJ-3040900-02

Date of Issue : November 12, 2002

Classification: New Changed Revised

PRODUCT SPECIFICATION FOR INFORMATION

Product Description : MULTILAYER VARISTOR CHIP TYPE (ZnO)

Product Part Number : EZJZSV270CAK
EZJZSV270DAK

Classification of Spec : SPECIFICATION

Applications :

For other applications contact our person signed below.

Term of Validity : November 11, 2007 from the date of issue

When either your company or our company has no offer by document until three months before the termination of the validity date mentioned in this specification, the validity date of this specification shall be continuously extended one more year every year.

In addition to the above, if revision is performed during effective term and you have confirmed, old specification shall be invalidity.

CUSTOMER USE ONLY	Receipt Record # :
This was certainly received by us. 1(one) copy is being returned to you.	Date of Receipt :
	Received by :
	Title:
	Dept :

Ceramic Business Unit
LCR Device Company
Matsushita Electronic Components Co., Ltd.
〒571-8506 1006 Kadoma, Osaka, Japan
Tel : Osaka (06) 6908-1101
Fax : Osaka (06) 6908-7735

Prepared by : Engineering Section
Contact Person : <u>Y. Sasakawa</u> Title : Engineer
Authorized by : <u>H. Iwano</u> Title : Manager of Engineering

- This product has not been manufactured with any ozone depleting chemical controlled under the Montreal Protocol.
- All the materials used in this part contain no brominated materials of PBBOs or PBBs as the flame retardant.
- All the materials used in this part are registered material under the Law Concerning the Examination and Regulation of Manufacture, etc. of Chemical Substances.

CLASSIFICATION	SPECIFICATION	REF. No.
PRODUCT	MULTILAYER VARISTOR CHIP TYPE (Zinc Oxide)	151S-EZJZ-S-270CAK
PART NUMBER	EZJZSV270CAK	1-1

Item	Requirements	Test Specifications
------	--------------	---------------------

1. Structure

1.1	Appearance	Without dirt and crack		
1.2	Dimensions	L	1.37 ± 0.15	
		W	1.00 ± 0.15	
		T	0.66 max.	
		BW	0.36 ± 0.10	
		BW1	0.20 ± 0.10	
		P	0.64 ± 0.10	
		unit:mm		

2. Electrical Requirements

2.1	Maximum allowable voltage	DC 16 V	
2.2	Varistor voltage	$27V \pm 15\%$	Measuring current DC 1mA
2.3	Capacitance	$22pF \pm 10\%$	Measuring voltage 1.0 Vrms. Measuring frequency 1MHz
2.4	Clamping voltage	50 Vmax.	Impulse waveform 8/20 μ s Impulse current 1A
2.5	Maximum peak current	5A	Impulse waveform 8/20 μ s Repetition times 2 times (5 minutes interval)

Note:

DATE	HOKKAIDO MATSUSHITA ELECTRIC CO.,LTD.	APPROVAL	CHECK	DESIGN
Nov.11.2002		<i>H. Atsuo</i>	<i>I. Sato</i>	<i>M. Sasaki</i>

CLASSIFICATION	SPECIFICATION	REF. No.
PRODUCT	MULTILAYER VARISTOR CHIP TYPE (Zinc Oxide)	151S-EZJZ-S-270DAK
PART NUMBER	EZJZSV270DAK	1-1

Item	Requirements	Test Specifications
------	--------------	---------------------

1. Structure

1.1	Appearance	Without dirt and crack		
1.2	Dimensions	L	1.37 ± 0.15	
		W	1.00 ± 0.15	
		T	0.66 max.	
		BW	0.36 ± 0.10	
		BW1	0.20 ± 0.10	
		P	0.64 ± 0.10	
		unit: mm		

2. Electrical Requirements

2.1	Maximum allowable voltage	DC 16 V	
2.2	Varistor voltage	27V ± 15%	Measuring current DC 1mA
2.3	Capacitance	27pF ± 10%.	Measuring voltage 1.0 Vrms. Measuring frequency 1MHz
2.4	Clamping voltage	50 Vmax.	Impulse waveform 8/20 μs Impulse current 1A
2.5	Maximum peak current	5A	Impulse waveform 8/20 μs Repetition times 2 times (5 minutes interval)

Note:

DATE	HOKKAIDO MATSUSHITA ELECTRIC CO.,LTD.	APPROVAL	CHECK	DESIGN
Nov.11.2002		<i>[Signature]</i>	<i>[Signature]</i>	<i>[Signature]</i>

CLASSIFICATION	SPECIFICATION	REF. No.
PRODUCT	MULTILAYER VARISTOR CHIP TYPE (Zinc Oxide)	151S-EZJZ-S-C01
PART NUMBER	COMMON SPESIFICATION	6 - 1

Item	Requirements	Test Specifications
------	--------------	---------------------

3. Mechanical Requirements

3.1	Substrate bending	Without mechanical damage	Bending stress 2mm Bending speed 1.0mm/sec. Hold time 5sec.
3.2	Solderability	Approximately 75% of the terminals shall be covered with new solder uniformly	Solder temp. 230±5°C Dipping period 4±1 sec.
3.3	Resistance to soldering heat	Without mechanical damage $\Delta V+1mA \leq \pm 10\%$	Solder temp. 270±5°C Dipping period 3.0±0.5 sec.

4. Enviromental Requirements

4.1	Temperature cycle	Without mechanical damage $\Delta V+1mA \leq \pm 10\%$	Cycles 5 cycles <table border="1" data-bbox="853 840 1228 1075"> <thead> <tr> <th>Step</th> <th>Temperature</th> <th>Period</th> </tr> </thead> <tbody> <tr> <td>1</td> <td>-40±3°C</td> <td>30 min.</td> </tr> <tr> <td>2</td> <td>Room temp.</td> <td>5 min.</td> </tr> <tr> <td>3</td> <td>85±5°C</td> <td>30 min.</td> </tr> <tr> <td>4</td> <td>Room temp.</td> <td>5 min.</td> </tr> </tbody> </table>	Step	Temperature	Period	1	-40±3°C	30 min.	2	Room temp.	5 min.	3	85±5°C	30 min.	4	Room temp.	5 min.
Step	Temperature	Period																
1	-40±3°C	30 min.																
2	Room temp.	5 min.																
3	85±5°C	30 min.																
4	Room temp.	5 min.																
4.2	Damp heat load	$\Delta V+1mA \leq \pm 10\%$	Ambient condition 40±2°C, 90~95%RH Applied voltage Max. allowable voltage Test period 500+24 h - 0															
4.3	Dry heat load	$\Delta V+1mA \leq \pm 10\%$	Ambient condition 85±5°C Applied voltage Max. allowable voltage Test period 500+24 h - 0															

Operating temperature range -40 to 85 C

Note:

DATE	HOKKAIDO MATSUSHITA ELECTRIC CO.,LTD.	APPROVAL	CHECK	DESIGN
Nov.11.2002		<i>H. Arai</i>	<i>Y. Sato</i>	<i>Y. Sasaki</i>

CLASSIFICATION		SPECIFICATION		No.
SUBJECT		MULTILAYER VARISTOR CHIP TYPE (Zinc Oxide) TEST METHOD (COMMON SPECIFICATION)		151S-EZJZ-S-C01
		6 - 2		
Characteristics		Test Method		
Standard test condition		<p>Unless otherwise specified all test and measurements shall be made at a temperature of 15~35°C and at a relative humidity of 45~75%RH .</p> <p>If results obtained are doubted a further test should be carried out at a temperature of 20±2°C and a relative humidity of 60~70%RH.</p>		
2. Electrical requirements				
2.1	Max.allowable voltage	The maximum DC voltage that can be applied continuously in the specified operating temperature.		
2.2	Varistor voltage	<p>The voltage between two terminals with the specified measuring current 1mA DC applied is called V1mA.</p> <p>The measurement shall be made as fast as possible to avoid heat affection.</p>		
2.3	Capacitance	Capacitance shall be measured at 1MHz±10%,0.2~2.0Vrms.,0V bias and 25°C.		
2.4	Clamping voltage	The maximum voltage between two terminals with the specified standard impulse current(8/20 μ s) .		
2.5	Maximum peak current	The maximum current within the varistor voltage change of ±10% when a standard impulse current of 8/20 μ s is applied two times with an interval of 5 minutes.		
2.6	Maximum ESD	<p>The maximum ESD within the varistor voltage change of ±30% when a standard impulse ESD is applied.</p> <p>* ESD : Electrostatic Discharge</p>		
Note:				

CLASSIFICATION	SPECIFICATION		No.
SUBJECT	MULTILAYER VARISTOR CHIP TYPE (Zinc Oxide) TEST METHOD (COMMON SPECIFICATION)		151S-EZJZ-S-C01 6 - 3
Characteristics		Test Method	
3. Mechanical requirements			
3.1	Substrate bending	After soldering specimen on the substrate, 2mm of bending shall be applied . Bending speed : 0.5mm/s .	
3.2	Solderability	Dip the specimen in solder so that both terminals electrodes are completely submerged. Use solder H63A(JIS -Z-3282). For the flux, about 25% by weight. Use tweezer for the holder to dip the specimen.	
3.3	Resistance to soldering heat	Dip the specimen in molten solder so that both terminals electrodes are completely submerged. Before dipping preheat the specimen according to the table below. After test, the specimen shall be left to stand at room temperature for 24±2 hours. The change of V1mA and mechanical damage shall be examined.	
4. Enviromental requirements			
4.1	Temperature cycle	Solder the specimen to the testing jig. Condition the spesimen to each temperature from step 1 to 4 in this order for the period shown in the table of specifications. Before the measurement after test, the specimen shall be left to stand at room temperature for 24±2 hours. The change of V1mA and mechanical damage shall be examined.	
4.2	Damp heat load	Solder the specimen to the testing jig. The specimen shall be applied continuously the Maximum allowable voltage at apesified conditions for specified period and then stored at room temperature and normal humidity for 24±2 hours. Thereafter, the change of V1mA and mechanical damage shall be examined.	
4.3	Dry heat load	Solder the specimen to the testing jig. The specimen shall be applied continuously the Maximum allowable voltage at apesified conditions for specified period and then stored at room temperature and normal humidity for 24±2 hours. Thereafter, the change of V1mA and mechanical damage shall be examined.	
Note:			

CLASSIFICATION	SPECIFICATION	No.
SUBJECT	MULTILAYER VARISTOR CHIP TYPE (Zinc Oxide) TAPED AND REELED PACKAGE SPECIFICATION (COMMON SPECIFICATION)	151S-EZJZ-S-C01
		6 - 4

1. Scope

This specification applies to the taped and reeled packaging for 'MULTILAYER VARISTOR CHIP TYPE (Zinc Oxide)'.

2. Applicable standars

EIAJ (Electric industries assosiation of japan) Standard EIAJ RC-1009B
JIS (Japanese Industrial standard) Standard JIS 0806

3. Packing specificaton

3.1 Structure and dimensions

- (1)Carrier tape : Shown in Fig,1
- (2)Reel : Shown in Fig,2
- (3)Packaging : We shall pack suitable in order to prevent damage during transportation or storage.

3.2 Packing Quantity

Type	Quantity (pcs./reel)
2 array	4000

3.3 Structure of taping

(1)The direction of winding of taping on the reel shall be in accordance with the following diagram.

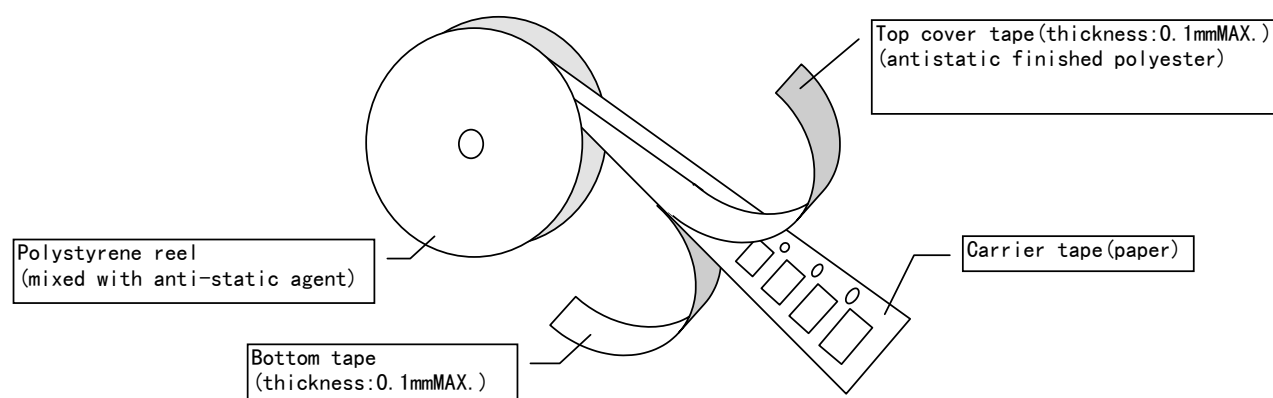

Note:

CLASSIFICATION	SPECIFICATION	No.
SUBJECT	MULTILAYER VARISTOR CHIP TYPE (Zinc Oxide) TAPED AND REELED PACKAGE SPECIFICATION (COMMON SPECIFICATION)	151S-EZJZ-S-C01
		6 - 5

(2)The specification of the leader and empty portion shall be in accordance with the following diagram.

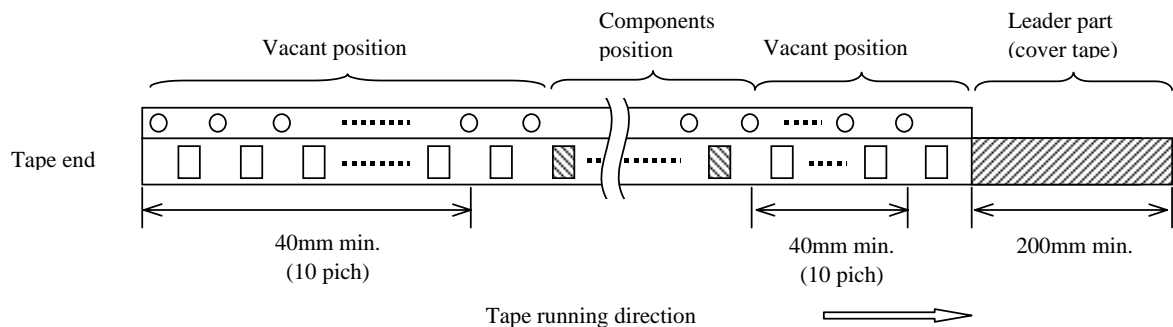

3.4 Marking on the reel

On the side of the reel we shall indicate no fewer than the items.

- (1)Part number
- (2)Quantity
- (3)Lot number

4. Efficiency

4.1 Breakage strength of the tape

1.0 N (approx.1 kgf) or more.

4.2 Peel strength of the tape (refer to the following figure).

- (1)Peel angle : 165 to 180 degree from the tape adhesive face.
- (2)Peel velocity : 300 mm per min.
- (3)Peel strength : 0.1 to 0.7 N (approx. 10 to 70 gf).

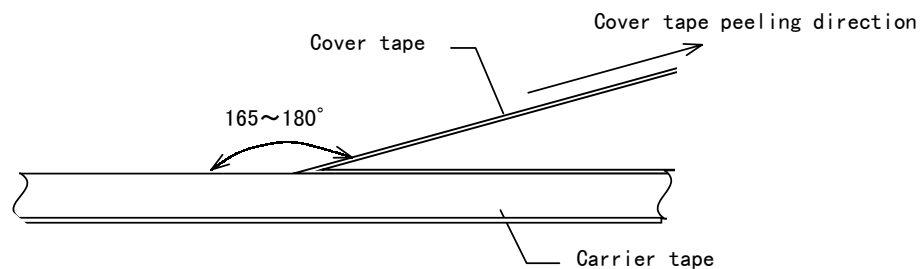

4.3 Barrs on tape

There shall be no barrs proventing section when products are taken out.

4.4 Missing of products

The missing of products shall be 0.1% or less per reel and there shall be no continuous missing of products

4.5 Adherence to the tape

Products shall be not be stuck to the cover tape or bottom tape.

Note:

CLASSIFICATION	SPECIFICATION	No.
SUBJECT	MULTILAYER VARISTOR CHIP TYPE (Zinc Oxide) TAPED AND REELED PACKAGE SPECIFICATION (COMMON SPECIFICATION)	151S-EZJZ-S-C01
		6 - 6

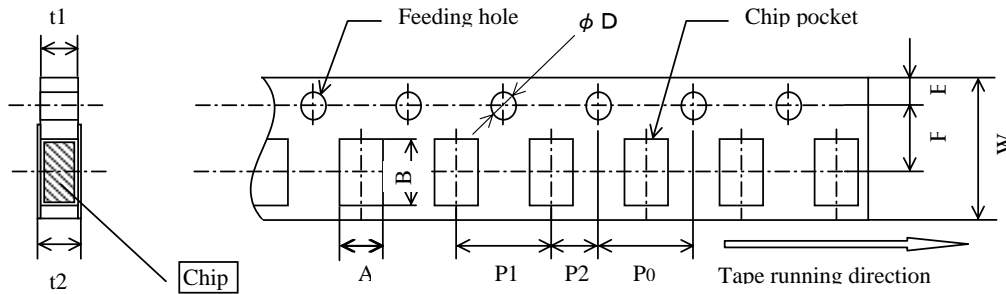

Code	Dimension
W	8.0±0.2
F	3.50±0.05
E	1.75±0.10
P0	4.0±0.1
P1	4.0±0.1
P2	2.00±0.05
D0	$\phi 1.5 \begin{matrix} +0.1 \\ -0 \end{matrix}$

(unit : mm)

Code	Dimension
A	1.18 ± 0.05
B	1.63 ± 0.05
t1	1.1 max.
t2	1.4 max.

Fig.1 Carrier tape dimension

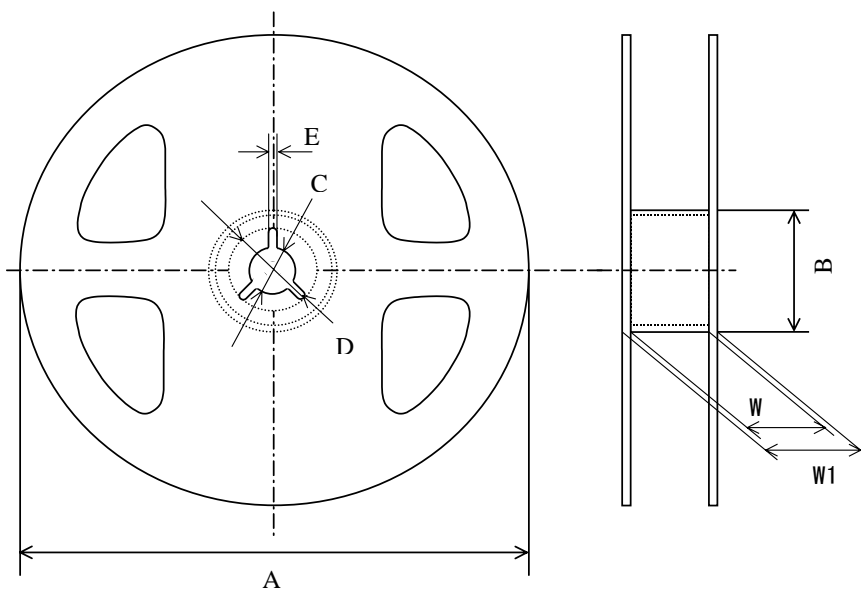

Code	Dimension
A	$\phi 180 \begin{matrix} +0 \\ -3.0 \end{matrix}$
B	$\phi 60 \pm 0.5$
C	13.0±0.5
D	21.0±0.8
E	2.0±0.5
W	9.0±0.3
W1	11.4±1.0

(unit : mm)

Fig.2 Reel Dimension

Note:

CLASSIFICATION	SPECIFICATION	No.
SUBJECT	MULTILAYER VARISTOR CHIP TYPE (Zinc Oxide)	151S-EZJZ-C04-R01
		10 - 1

Precautions for Safety

The Multilayer Varistor (hereafter referred to as "The Varistors") may fail in a short circuit mode on in an open-circuit mode, when subjected to severe conditions of electrical, environmental and/or mechanical stresses beyond the specified "Ratings" and specified "Conditions" in the Catalog and the Specifications, resulting in burnout, flaming or glowing in the worst case.

Following "Precautions for Safety" and "Application Notes" shall be taken in your major consideration. If you try to apply our product for the following electronic equipments, or have any question, please contact us.

- Artificial satellite, cosmic rocket
- Aircraft
- Seabed repeater
- Traffic/transport system (automobile, aircraft, rolling stock, ship, traffic signal control equipment)
- Electric power plant (nuclear power, thermal power, hydraulic power generation)
- Medical equipment
- Information processing system
- Security system
- Rotating machine

1. Operating Conditions and Circuit Design

- (1) The Varistors shall not be operated beyond the specified "Ratings" and "Environmental Conditions" in the Catalog or the Specifications to prevent them from deterioration, breakdown, flaming or glowing.
 - 1.1 The Varistors shall not be operated beyond the specified "Operating Temperature Range" in the Catalog or the Specifications.
 - 1.2 The Varistors shall not be in "AC power circuit".
 - 1.3 The Varistors shall not be operated exceeding the specified "Maximum Allowable Voltage" in the Catalog or the Specification.
 - 1.4 The Varistors shall not be subjected to energy levels above their specified "Maximum energy Ratings" in the Catalog or the Specifications.
- (2) The Varistors shall be operated correctly under following conditions to prevent Varistors from causing mechanical damages and ruptures and to protect human from serious injuries.
 - 2.1 The Varistors shall not be operated exceeding the specified "Maximum Allowable Voltage" in the Catalog or the Specification.
 - 2.2 The Varistors shall not be operated exceeding the specified "Maximum Peak Current Ratings" in the Catalog or the Specification.
- (3) It is recommended that the Varistors, if not fused, shall not be located away from other combustible components.

Note :

CLASSIFICATION	SPECIFICATION	No.
SUBJECT	MULTILAYER VARISTOR CHIP TYPE(Zinc Oxide)	151S-EZJZ-C04-R01
		10 - 2

2. Restriction on environmental conditions

The varistors shall not be operated and / or stored under following environmental conditions.

(1) Environmental conditions

- (a) To be exposed directly to water or salt water.
- (b) Under conditions of dew formation.
- (c) Under conditions of corrosive atmosphere such as hydrogen sulfide, sulfurous acid, chlorine or ammonia etc..

(2) Under severe conditions of extreme vibrations or shocks.

3. Precautions for Printed-Circuit-Board Design

3.1 Selection of printed circuit board

When the varistors are mounted and soldered on an "Aluminum substrate", the substrate has influences on varistors reliabilities against "Temperature cycles" and "Heat shock" because of difference of thermal expansion coefficient between them. It shall be carefully confirmed that the actual board applied does not deteriorate the characteristics of the varistors.

3.2 Design of land pattern

Recommended dimensions of lands ; As shown in table 1 and Fig. 1

- (1) If the land area is too large, the amount of solder will become so large that the cracks will occur in the varistor when soldering.

The land size shall be not exceed the varistor width.

Fig.1 Recommended land dimensions(Ex.)

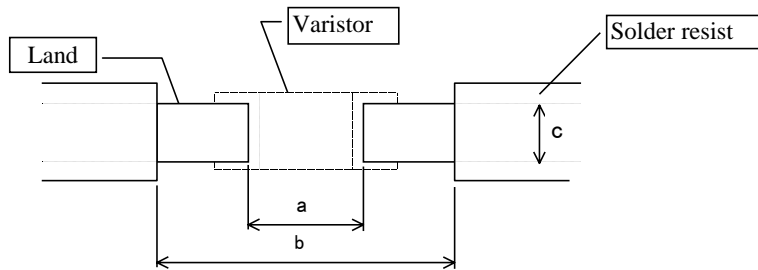

Table.1

(Unit:mm)

Type (size)	Component dimension			Flow soldering			Reflow soldering		
	L	W	T	a	b	c	a	b	c
0402(1005)	1.0	0.5	0.5	—	—	—	0.5 to 0.6	1.5 to 1.7	0.5 to 0.6
0603(1608)	1.6	0.8	0.8	0.8 to 1.0	2.0 to 2.6	0.6 to 0.8	0.8 to 1.0	2.0 to 2.6	0.8 to 1.0
0805(2012)	2.0	1.25	0.85	1.0 to 1.4	3.0 to 3.8	0.8 to 1.0	0.8 to 1.2	2.4 to 3.2	1.0 to 1.2

Note:

CLASSIFICATION	SPECIFICATION	No.
SUBJECT	MULTILAYER VARISTOR CHIP TYPE(Zinc Oxide)	151S-EZJZ-C04-R01
		10 - 4

Table 2 Applications of Solder Resist

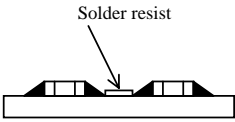
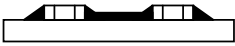
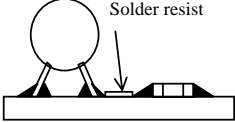
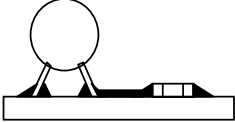
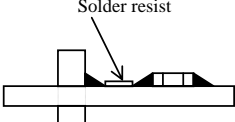
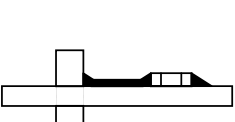
	Good Ex.	Bad Ex.
Two or more chip components contact each other.		
Lead components are directly connected to chip components.		
Common lands(chassis etc.) are close to chip components.		

4. Precautions for Mounting for assembly

4.1 Storage

- (1) Varistors shall not be stored under servers conditions of high temperature and humidity . Store them indoors under at 5 to 40°C or less and 20 to 70%RH or less.
- (2) If the storage place is humidity , dust , and contains corrosive gasses (hydrogen sulfide ,sulfurous acid , hydrogen chloride and ammonia etc.), the solderability of the external electrode may be reduced. Storage in a place exposed to heat and direct sunlight causes deformation of the reels and tapes of tapepackaged products and adhesion of components to tapes, which results in troubles in case of mounting.
- (3) The period of storage not exceed 6 months. For products stored for more than 6 months , their solderability shall be checked before they are used.

4.2 Adhesives for mounting

- (1) The viscosity of a adhesive for mountings shall be such that the adhesive does not flow off on the land during it's curing.
- (2) If the adhesive is too low its viscosity , mounted components may be out aligment after or during soldering.
- (3) The adhesive shall not be corrosive or chemically active

Note:

CLASSIFICATION	SPECIFICATION	No.
SUBJECT	MULTILAYER VARISTOR CHIP TYPE(Zinc Oxide)	151S-EZJZ-C04-R01
		10 - 5

- (4) The amount of adhesive shall be such that the adhesive does not flow off or be out of alignment.
- (5) Adhesives for mountings can be cured by ultraviolet or infrared radiation.
In order to prevent the terminal electrodes of the varistors from oxidizing.
The curing shall be done at conditions of 160°C max., for 2 minutes max..

4.3 Chip mounting consideration

In mounting the varistors/components on a printed circuit board, /any bending and expanding force against them shall be kept minimum to prevent them from bending damaged or cracked.

Following precautions and recommendations shall be observed carefully in the process.

- (1) Maximum stroke of the vacuum nozzle shall be adjusted so that the pushing force to the printed circuit board shall be limited to a static load of 1 to 3N(100 to 300gf).
- (2) Maximum stroke of the nozzle shall be adjusted so that the maximum bending of printed circuit board does not exceed 0.5mm.

Fig.3 Bottom dead point height of the vacuum nozzle

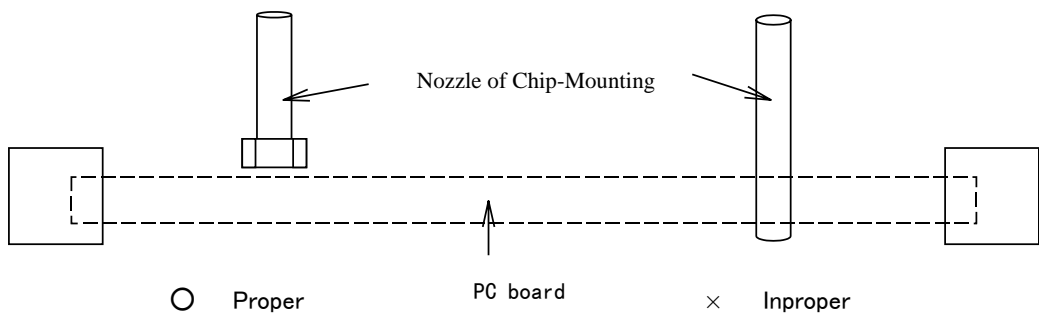

- (3) The printed circuit board shall be supported by means of adequate supporting pins.

Fig.4 Backup pins

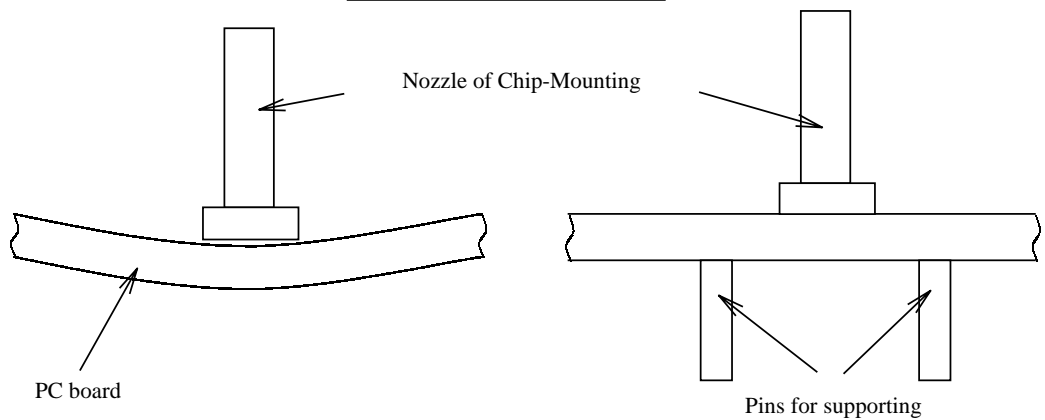

Note:

CLASSIFICATION	SPECIFICATION	No.
SUBJECT	MULTILAYER VARISTOR CHIP TYPE(Zinc Oxide)	151S-EZJZ-C04-R01
		10 - 6

4.4 Soldering flux and solder

(1) Soldering flux

The content of halogen in the flux shall be 0.2wt% (Cl conversion) or less. Rosin-based and non-activated soldering flux is recommended.

(2) Water soluble type soldering flux

In case of water soluble type soldering flux being applied, the flux residue on the surface of P.C. board may have influences on the reliability of the components and cause deterioration and failures of them.

(3) Solder

An eutectic solder (Sn:63,Pb:37) is recommended.

4.5 Soldering

4.5.1 Flow soldering

In flow soldering process, abnormal and large thermal and mechanical stresses, caused by "Temperature Gradient" between the mounted varistor and melted solder in a soldering bath, may be applied directly to the varistors, resulting in failures and damages of the varistors.

So it is essential that soldering process shall be controlled to the following recommended conditions.

(1) Application of flux

The soldering flux shall be applied to the mounted varistor thinly and uniformly by forming method.

(2) Preheating

The mounted varistors/components shall be preheated sufficiently so that the "Temperature Gradient" between the varistors/components and the melted solder shall be 150°C or below.

(3) Immersion to soldering bath

The varistors shall be immersed into a soldering bath of 240 to 250°C for 3 to 5 seconds.

(4) Cooling

The varistor shall be cooled gradually to room ambient temperature with the cooling temperature rates of 8 °C/s max. from 250 to 170°C and 4 °C/s max. from 170 to 130°C.

(5) Flux cleaning

When the varistors are immersed into cleaning solvent, it shall be confirmed that the surface temperature of devices do not exceed 100°C.

(6) There is no problem with twice flow soldering under the conditions described in the diagram

[Recommended Profile for Flow Soldering (Example)] below.

Care shall , however ,be taken to prevent board warp or bend.

Note:

CLASSIFICATION	SPECIFICATION	No.
SUBJECT	MULTILAYER VARISTOR CHIP TYPE(Zinc Oxide)	151S-EZJZ-C04-R01
		10 - 7

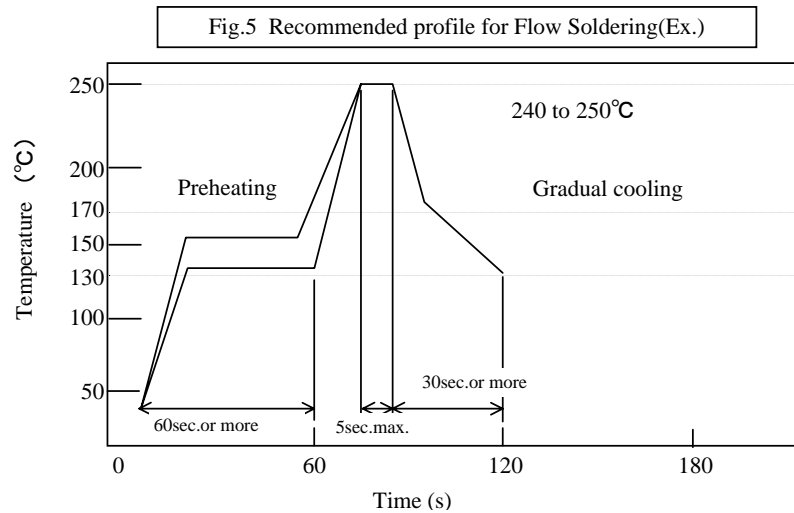

4.5.2 Reflow soldering

In reflow soldering process, the mounted varistors/components are generally heated and soldered by a thermal conduction system such as an "Infrared radiation and hot blast soldering system " or a "Vapour Phase Soldering System (VPS) ". Large temperature gradients such as a rapid heating and cooling in the process may cause electrical failures and mechanical damages of the device.

It is essential that the soldering process shall be controlled by the following recommended conditions and precautions.(See Fig.6)

(1) Preheating 1

The mounted varistors/components shall be preheated sufficiently , for 60 to 90 seconds so that the surface temperatures of them to be 140 to 160°C .

(2) Preheating 2

After "Preheating 1 ", the mounted varistors/components shall be heated to the elevated temperatures of 150 to 200°C for 2 to 5 seconds.

(3) Soldering

The mounted varistors/components shall be heated under the specified heating conditions (200 to 240 to 200°C for total of 20 to 40 seconds, See Fig. 10) and shall be soldered at the maximum temperature of 240°C to 10 seconds or less.

(4) Cooling

After the soldering , the mounted varistors/components shall be granually cooled to room amnient temperature for preventing mechanical damages such as crackings of the devices.

(5) Flux Cleaning

When the varistors are immersed into cleaning solvent , it shall be confirmed that the surface temperature of devices do not exceed 100°C.

Note:

CLASSIFICATION	SPECIFICATION	No.
SUBJECT	MULTILAYER VARISTOR CHIP TYPE(Zinc Oxide)	151S-EZJZ-C04-R01
		10 - 8

- (6) There is no problem with twice flow soldering under the conditions described in the diagram [Recommended Profile for Flow Soldering(Example)] below.
Care shall ,however ,be taken to prevent board warp or bend.

Note: If the mounted varistors/components are partially heated in the soldering process, the devices may be separated from the printed circuit board by surface tension of partially melted solder, and stand up like a "Tomb stone".

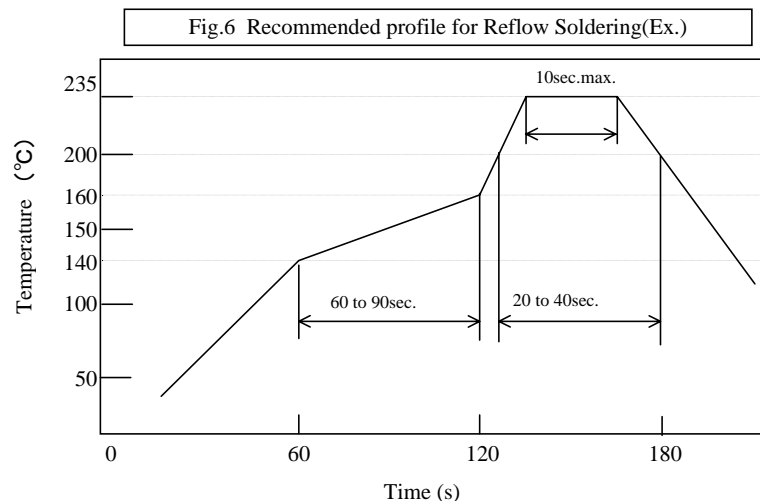

4.5.3 Hand Soldering

In hand soldering of the varistors , large temperature gradient between preheated the varistors and the tip of soldering iron may cause electrical failures and mechanical damages such as crackings or breaking of the devices. The soldering shall be carefully controlled and carried out so that the temperature gradient is kept minimum with following recommended conditions for hand soldering.

- (1) Solder
 ϕ 1mm Thresd euetic solder with soldering flux in the core.(Rosin-based,and non-sctivated flux is recommended)
- (2) Preheating
The varistors shall be preheated so that "Temperature Gredient" between the devices and the tip of soldering iron is 150°C or below.
- (3) Solder Iron
Rated Power of 20W max. with 3mm soldering iron tip in diameter.
- (4) Temperature of soldering iron tip ; 300°C max.
(The required amount of solder shall be melted in advance on the soldering tip.)
- (5) Cooling
After the soldering, the varistors shall be cooled gradually at room ambient temperature.

Note:

CLASSIFICATION	SPECIFICATION	No.
SUBJECT	MULTILAYER VARISTOR CHIP TYPE(Zinc Oxide)	151S-EZJZ-C04-R01
		10 - 9

Fig.7 Recommended Soldering by Hand Soldering(Ex.)

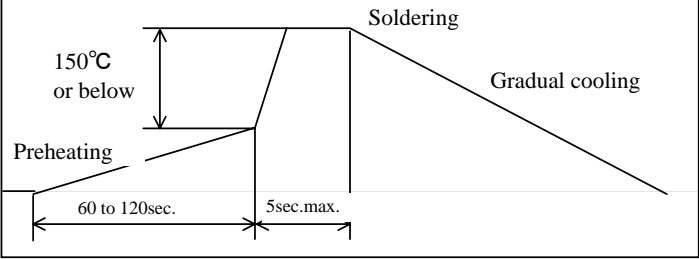

4.6 Post Soldering Cleaning

- (1) Residues of corrosive soldering fluxes on the PC board after cleaning may greatly have influences on the electrical characteristics and the reliability (such as humidity resistance) of the varistors which have been mounted on the board, it shall be confirmed that the characteristics and the reliability of the devices are not affected by the applied cleaning conditions.
- (2) Solubility of alternative cleaning solvent such as alcohol etc., is inferior to that of freon cleaning solvent in the flux cleaning.
So in a case of alternative cleaning solvents applied, fresh cleaning solvent always shall be used, and sufficient rinsing and drying shall be carried out.
- (3) When an ultrasonic cleaning is applied to the mounted varistors on PC boards, following conditions are recommended for preventing failures or damages of ultrasonic waves.
Frequency ; 29kHz max.
Period ; 5 minutes max.

4.7 Process Inspection

When the surface of a printed board on which the varistors has been mouted is coated with resin to protect against moisture and dust, it shall be confirmed that the protective coat does not have influences on reliability of the varistors in the actual equipment.



- (1) Coating materials, such as being corrosive and chemically active, shall not be applied to the varistors and other components.
- (2) Coating materials with large exansivity shall not be applied to the varistors for preventing failures or damages (such as crackings) of the devices in the curing process.

Note:

CLASSIFICATION	SPECIFICATION	No.
SUBJECT	MULTILAYER VARISTOR CHIP TYPE(Zinc Oxide)	151S-EZJZ-C04-R01 10 - 10
<p>4.8 Dividing / Breaking of PC Boards</p> <p>(1) Abnormal and excessive mechanical stresses, such as bending or expanding force on the components on the printed circuit board, shall be kept minimum in the dividing / breaking.</p> <p>(2) Dividing / Breaking of the PC boards shall be done carefully at moderate speed by using a jig or apparatus to prevent the varistors on the boards from mechanical damages.</p> <p>5. Product place</p> <p>Hokkaido Matsushita Electric Co.,Ltd. / 1037-2 , Kamiosatsu, Chitose-shi , Hokkaido , Japan</p>		
<p>Note:</p>		

Looking for pricing, stock, or lifecycle information?

Click below to explore more details on WIN SOURCE:

-  [View EZJ-ZSV270DAK](#) on WIN SOURCE
-  [Panasonic](#) Information

Optimize Your Supply Chain with WIN SOURCE Solutions

-  Global Sourcing Solution
-  Obsolete Management
-  Cost Control Management
-  Shortage Management
-  Alternative Solution
-  Excess Inventory Management