



**THE DATASHEET OF
ABM12-117-27.120MHZ-T3**



IoT OPTIMIZED LOW PROFILE QUARTZ CRYSTAL



1.6 x 1.2 x 0.40 mm

RoHS/RoHS II Compliant

MSL = N/A: NOT APPLICABLE (See Note #1)

ABM12-117-27.120MHz

FEATURES

- Optimized for low power consumption, wearables, and IoT applications
- Guaranteed low 80Ω ESR ensures operation in power sensitive solutions
- 0.40mm max height ideally suited for height constrained designs
- Seam sealed for longterm reliability

APPLICATIONS

- Wearables
- Internet of Things (IoT)
- Bluetooth/Bluetooth Low Energy (BLE)
- Wireless modules
- Machine-to-machine (M2M) connectivity
- Ultra-low power MCU
- Near Field Communication (NFC)
- ISM Band

STANDARD SPECIFICATIONS

PARAMETERS	MINIMUM	TYPICAL	MAXIMUM	UNITS	NOTES
Frequency	27.120			MHz	
Operation Mode	Fundamental				
Operating Temperature	-20		+70	°C	
Storage Temperature	-40		+125	°C	
Frequency Tolerance @+25°C	-10		+10	ppm	See Note#2
Frequency Stability over the Operating Temperature (ref. to +25°C)	-10		+10	ppm	See Note#3
Equivalent series resistance (R1)			80	Ω	
Shunt capacitance (C0)			2	pF	
Load capacitance (CL)	8			pF	
Drive Level		10	100	μW	
Aging@25°C±3°C			±3	ppm	First year
Insulation Resistance	500			MΩ	@ 100Vdc ± 15V

Note#1: Moisture Sensitivity Level (MSL) – This product is Hermetically Sealed and not Moisture Sensitive

Note#2: Referenced to crystal resonant frequency, into an oscillator loop effective load of 8pF

Note#3: Referenced to the measured frequency at 25°C±3°C, into an oscillator loop effective load of 8pF

REVISED: 06/21/2016



5101 Hidden Creek Lane Spicewood TX 78669
 Phone: 512-371-6159 | Fax: 512-351-8858
 For terms and conditions of sale visit:
www.abracon.com

ABRACON IS
 ISO9001-2008
 CERTIFIED

IoT OPTIMIZED LOW PROFILE QUARTZ CRYSTAL



ABM12-117-27.120MHz

1.6 x 1.2 x 0.40 mm

RoHS/RoHS II Compliant

MSL = N/A: NOT APPLICABLE (See Note #1)

PART IDENTIFICATION AND ORDERING INFORMATION

ABM12-117-27.120MHZ-

PACKAGING
Blank: Bulk
T3: 3K/Reel

MECHANICAL DIMENSIONS (ALL DIMENSIONS ARE IN mm)

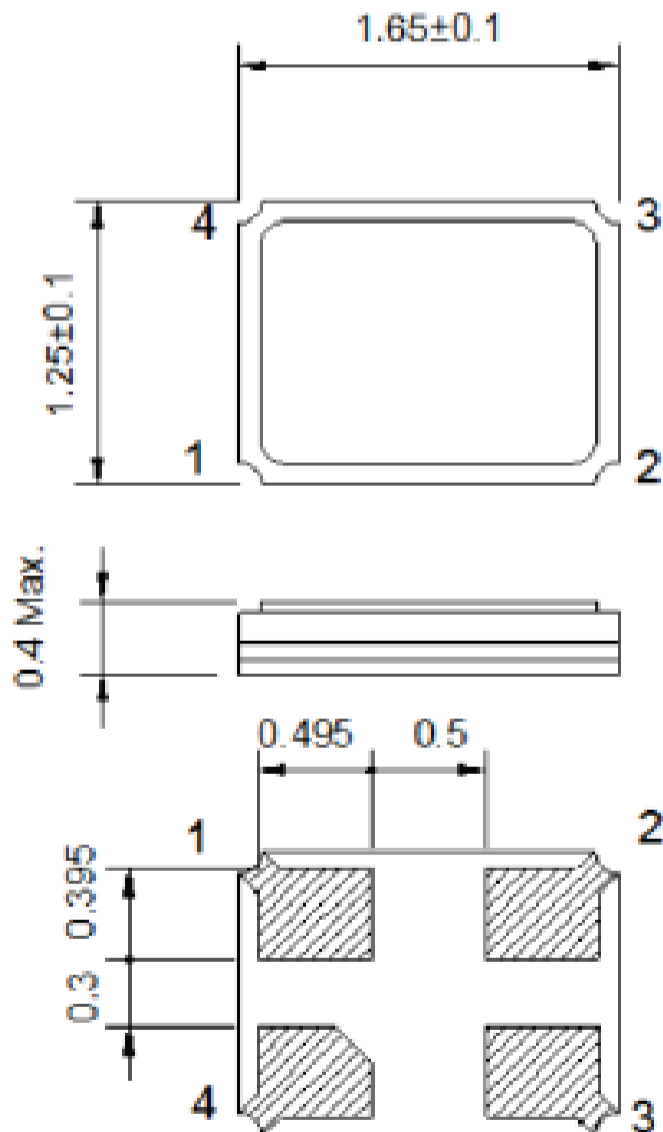

RECOMMENDED LAND PATTERN

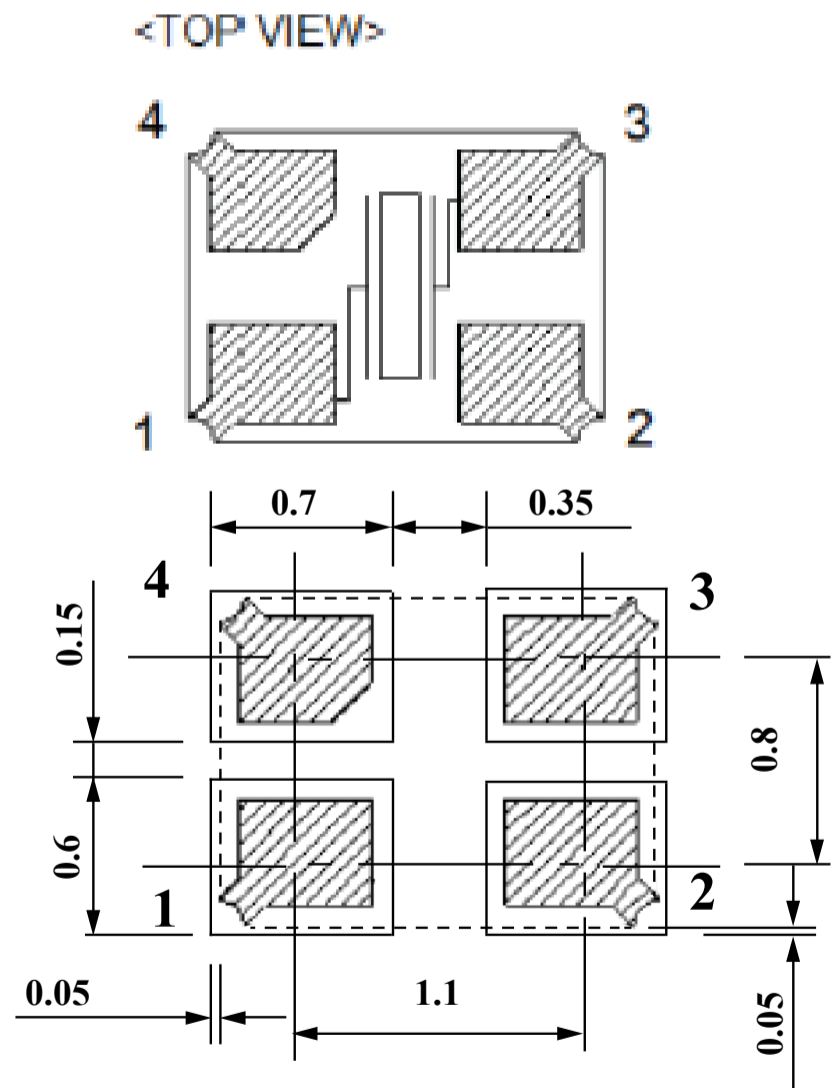

IoT OPTIMIZED LOW PROFILE QUARTZ CRYSTAL



ABM12-117-27.120MHz

1.6 x 1.2 x 0.40 mm

Pb | RoHS/RoHS II Compliant

MSL = N/A: NOT APPLICABLE (See Note #1)

REFLOW PROFILE

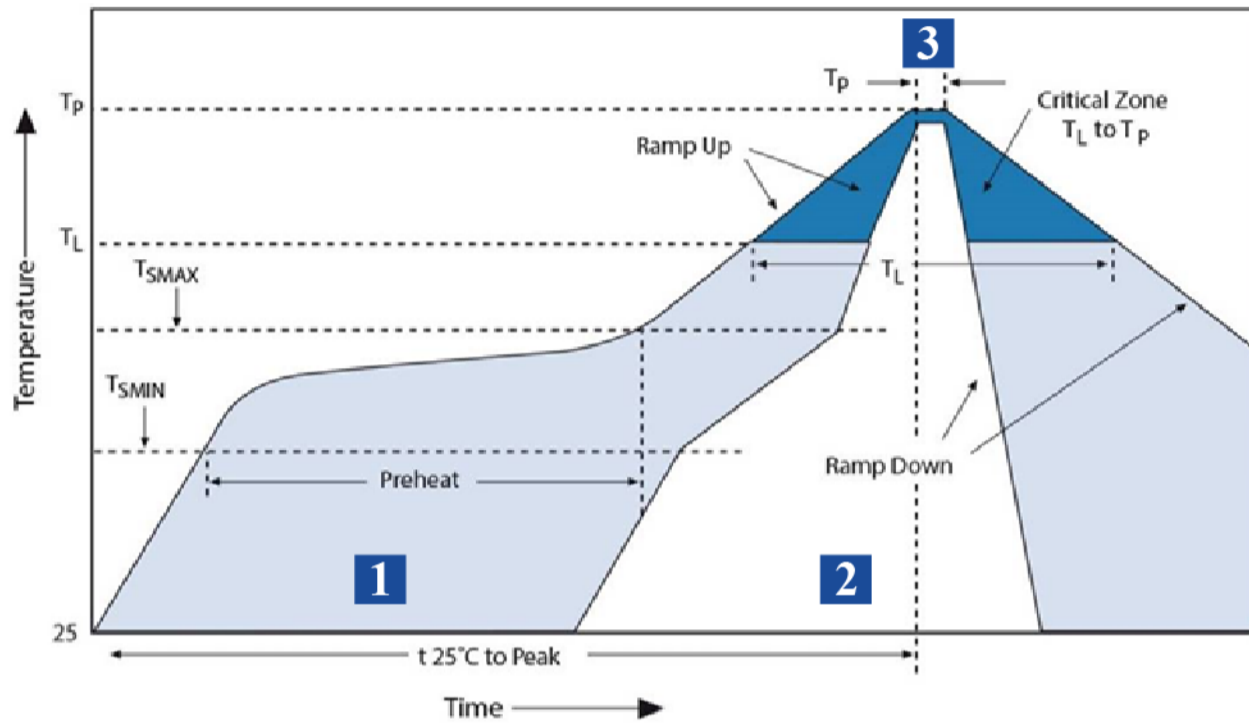

Zone	Description	Temperature	Time
1	Preheat	$T_{SMIN} - T_{SMAX}$ 160°C~180°C	120 sec.
2	Reflow	T_L 60°C	60 sec.
3	Peak Heat	T_P 260°C	10 sec. MAX

PACKAGING

T3: 3000PCS/REEL

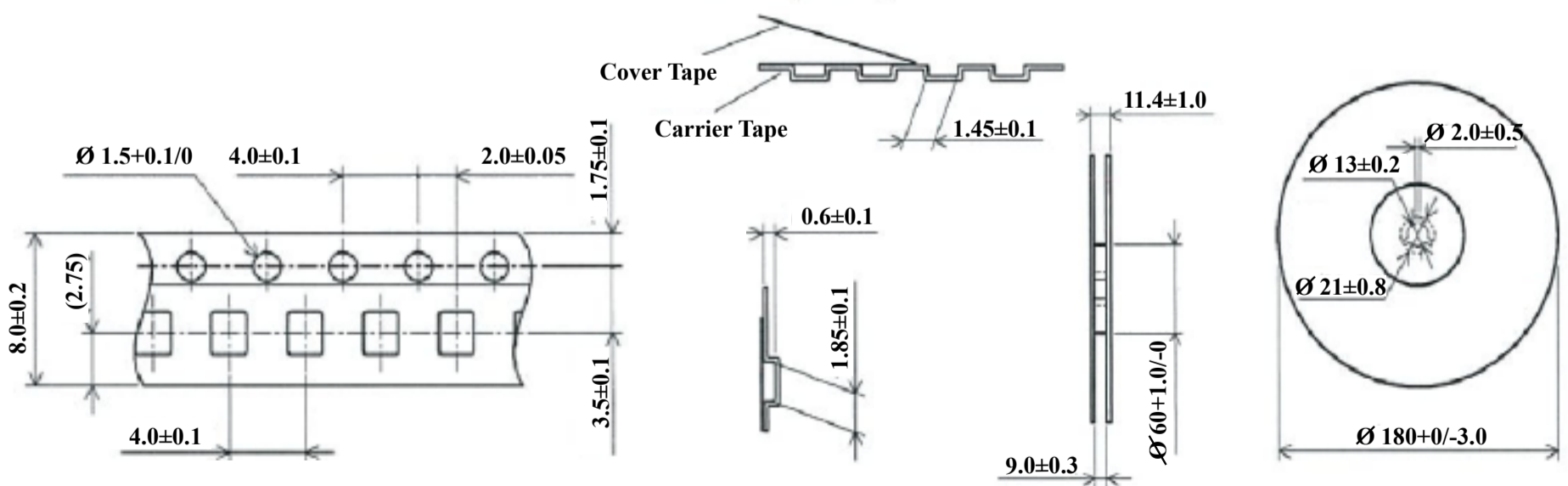

REVISED: 06/21/2016



5101 Hidden Creek Lane Spicewood TX 78669
 Phone: 512-371-6159 | Fax: 512-351-8858
 For terms and conditions of sale visit:
www.abracon.com

ABRACON IS
 ISO9001-2008
 CERTIFIED

Looking for pricing, stock, or lifecycle information?

Click below to explore more details on WIN SOURCE:

- [View ABM12-117-27.120MHZ-T3 on WIN SOURCE](#)
- [Abracon LLC Information](#)

Optimize Your Supply Chain with WIN SOURCE Solutions

- ✓ Global Sourcing Solution
- ✓ Obsolete Management
- ✓ Cost Control Management
- ✓ Shortage Management
- ✓ Alternative Solution
- ✓ Excess Inventory Management