

SN74LVC1G3157-Q1 Automotive Single-Pole Double-Throw Analog Switch

1 Features

- **Functional safety-capable**
 - Documentation available to aid functional safety system design
- AEC-Q100 qualified for automotive applications:
 - Temperature grade 1: -40°C to $+125^{\circ}\text{C}$, T_A
- ESD protection exceeds 2000 V per MIL-STD-883, method 3015; exceeds 200 V using machine model ($C = 200\text{ pF}$, $R = 0$)
- 1.65-V to 5.5-V V_{CC} operation
- Useful for analog and digital applications
- Specified break-before-make switching
- Rail-to-rail signal handling
- High degree of linearity
- High speed, typically 0.5 ns ($V_{CC} = 3\text{ V}$, $C_L = 50\text{ pF}$)
- Low ON-State resistance, typically $\#6\ \Omega$ ($V_{CC} = 4.5\text{ V}$)
- Latch-up performance exceeds 100 mA per JESD 78, Class II

2 Applications

- Advanced driver assistance systems (ADAS)

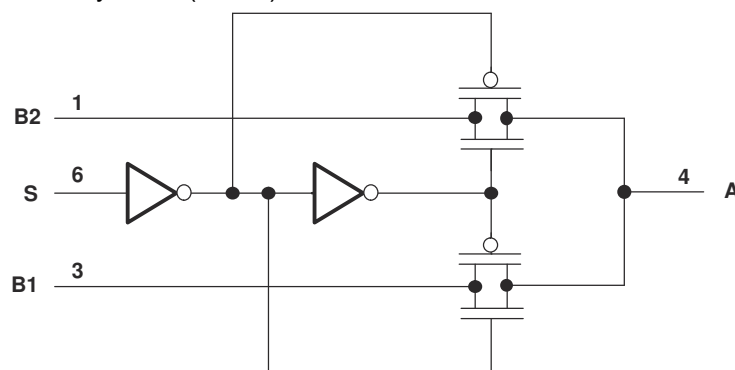

Logic Diagram (Positive Logic)

3 Description

The SN74LVC1G3157-Q1 device is a single-pole double-throw (SPDT) analog switch designed for 1.65-V to 5.5-V V_{CC} operation.

The SN74LVC1G3157 device can handle analog and digital signals. The device permits signals with amplitudes of up to V_{CC} (peak) to be transmitted in either direction.

Applications include signal gating, chopping, modulation or demodulation (modem), and signal multiplexing for analog-to-digital and digital-to-analog conversion systems.

Device Information⁽¹⁾

PART NUMBER	PACKAGE	BODY SIZE (NOM)
SN74LVC1G3157-Q1	SOT-23 (6)	2.90 mm × 1.60 mm
	SC70 (6)	2.00 mm × 1.25 mm

- (1) For all available packages, see the orderable addendum at the end of the data sheet.



Table of Contents

1 Features	1	8.3 Feature Description.....	15
2 Applications	1	8.4 Device Functional Modes.....	15
3 Description	1	9 Application and Implementation	16
4 Revision History	2	9.1 Application Information.....	16
5 Pin Configuration and Functions	3	9.2 Typical Application.....	16
6 Specifications	4	10 Power Supply Recommendations	17
6.1 Absolute Maximum Ratings.....	4	11 Layout	18
6.2 ESD Ratings.....	4	11.1 Layout Guidelines.....	18
6.3 Recommended Operating Conditions.....	5	11.2 Layout Example.....	18
6.4 Thermal Information.....	5	12 Device and Documentation Support	19
6.5 Electrical Characteristics.....	6	12.1 Documentation Support.....	19
6.6 Switching Characteristics.....	7	12.2 Receiving Notification of Documentation Updates..	19
6.7 Analog Switch Characteristics.....	7	12.3 Support Resources.....	19
6.8 Typical Characteristics.....	8	12.4 Trademarks.....	19
7 Parameter Measurement Information	9	12.5 Electrostatic Discharge Caution.....	19
8 Detailed Description	15	12.6 Glossary.....	19
8.1 Overview.....	15	13 Mechanical, Packaging, and Orderable Information	19
8.2 Functional Block Diagram.....	15		

4 Revision History

NOTE: Page numbers for previous revisions may differ from page numbers in the current version.

Changes from Revision G (April 2019) to Revision H (December 2021)	Page
• Updated the numbering format for tables, figures, and cross-references throughout the document.....	1
• Added functional safety text to the data sheet.....	1
<hr/>	
Changes from Revision F (March 2015) to Revision G (April 2019)	Page
• Changed the automotive <i>Features</i>	1
• Changed the <i>Pin Configuration</i> images.....	3
• Changed the <i>ESD Ratings</i> table.....	4
<hr/>	
Changes from Revision E (April 2008) to Revision F (March 2015)	Page
• Added <i>ESD Ratings</i> table, <i>Feature Description</i> section, <i>Device Functional Modes</i> , <i>Application and Implementation</i> section, <i>Power Supply Recommendations</i> section, <i>Layout</i> section, <i>Device and Documentation Support</i> section, and <i>Mechanical, Packaging, and Orderable Information</i> section	1

5 Pin Configuration and Functions

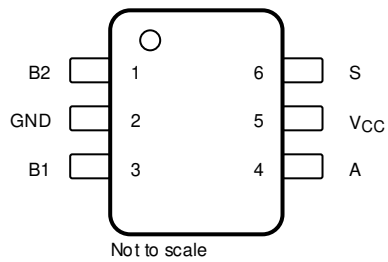

Not to scale
**Figure 5-1. DBV Package
6-Pin SOT-23
Top View**

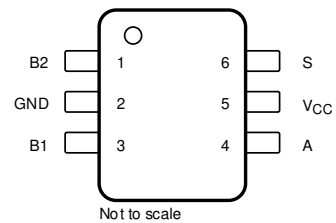

Not to scale
**Figure 5-2. DCK Package
6-Pin SC70
Top View**

Table 5-1. Pin Functions

PIN		TYPE ⁽¹⁾	DESCRIPTION
NAME	NO.		
A	4	I/O	Common terminal
B1	3	I/O	First terminal
B2	1	I/O	Second terminal
GND	2	—	Ground
S	6	I	Select
V _{CC}	5	I	Power supply

(1) I = input, O = output, GND = ground.

6 Specifications

6.1 Absolute Maximum Ratings

over operating free-air temperature range (unless otherwise noted)⁽¹⁾

		MIN	MAX	UNIT
V _{CC}	Supply voltage ⁽²⁾	-0.5	6.5	V
V _{IN}	Control input voltage ^{(2) (3)}	-0.5	6.5	V
V _{I/O}	Switch I/O voltage ^{(2) (3) (4) (5)}	-0.5	V _{CC} + 0.5	V
I _{IK}	Control input clamp current	V _{IN} < 0	-50	mA
I _{IOK}	I/O port diode current	V _{I/O} < 0	-50	mA
I _{I/O}	ON-state switch current	V _{I/O} = 0 to V _{CC} ⁽⁶⁾	±128	mA
Continuous current through V _{CC} or GND			±100	mA
θ _{JA}	Package thermal impedance ⁽⁷⁾	DBV package	165	°C/W
		DCK package	258	
T _{stg}	Storage temperature	-65	150	°C

(1) Stresses beyond those listed under *Absolute Maximum Ratings* may cause permanent damage to the device. These are stress ratings only, which do not imply functional operation of the device at these or any other conditions beyond those indicated under *Recommended Operating Conditions*. Exposure to absolute-maximum-rated conditions for extended periods may affect device reliability.

(2) All voltages are with respect to ground, unless otherwise specified.

(3) The input and output negative-voltage ratings may be exceeded if the input and output clamp-current ratings are observed.

(4) This value is limited to 5.5 V maximum.

(5) V_I, V_O, V_A, and V_{BN} are used to denote specific conditions for V_{I/O}.

(6) I_I, I_O, I_A, and I_{BN} are used to denote specific conditions for I_{I/O}.

(7) The package thermal impedance is calculated in accordance with JESD 51-7.

6.2 ESD Ratings

			VALUE	UNIT	
V _(ESD)	Electrostatic discharge	Human-body model (HBM), per AEC Q100-002 ⁽¹⁾ HBM ESD Classification Level 1C	±2000	V	
		Charged-device model (CDM), per AEC Q100-011 CDM ESD Classification Level C6	Other pins		±1000
			Corner pins (B2, B1, S, and A)		±1000

(1) AEC Q100-002 indicates that HBM stressing shall be in accordance with the ANSI/ESDA/JEDEC JS-001 specification.

6.3 Recommended Operating Conditions

over operating free-air temperature range (unless otherwise noted)⁽¹⁾

		MIN	NOM	MAX	UNIT
V_{CC}		1.65		5.5	V
V_{IO}		0		V_{CC}	V
V_{IN}		0		5.5	V
V_{IH}	High-level input voltage, control input	$V_{CC} = 1.65\text{ V to }1.95\text{ V}$		$V_{CC} \times 0.75$	V
		$V_{CC} = 2.3\text{ V to }5.5\text{ V}$			
V_{IL}	Low-level input voltage, control input	$V_{CC} = 1.65\text{ V to }1.95\text{ V}$		$V_{CC} \times 0.25$	V
		$V_{CC} = 2.3\text{ V to }5.5\text{ V}$			
$\Delta t/\Delta v$	Input transition rise/fall time	$V_{CC} = 1.65\text{ V to }1.95\text{ V}$		20	ns/V
		$V_{CC} = 2.3\text{ V to }2.7\text{ V}$			
		$V_{CC} = 3\text{ V to }3.6\text{ V}$			
		$V_{CC} = 4.5\text{ V to }5.5\text{ V}$			
T_A		-40		125	°C

(1) All unused inputs of the device must be held at V_{CC} or GND to ensure proper device operation. Refer to the TI application report, *Implications of Slow or Floating CMOS Inputs*, [SCBA004](#).

6.4 Thermal Information

THERMAL METRIC ⁽¹⁾		SN74LVC1G3157-Q1		UNIT
		DBV (SOT-23)	DCK (SC70)	
		6 PINS	6 PINS	
$R_{\theta JA}$	Junction-to-ambient thermal resistance	201.8	233.8	°C/W
$R_{\theta JC(top)}$	Junction-to-case (top) thermal resistance	103.7	107.9	
$R_{\theta JB}$	Junction-to-board thermal resistance	51.8	52.7	
Ψ_{JT}	Junction-to-top characterization parameter	12	4.9	
Ψ_{JB}	Junction-to-board characterization parameter	51.4	52.4	

(1) For more information about traditional and new thermal metrics, see the *IC Package Thermal Metrics* application report, [SPRA953](#).

6.5 Electrical Characteristics

over recommended operating free-air temperature range (unless otherwise noted)

PARAMETER		TEST CONDITIONS		V _{CC}	MIN	TYP ⁽¹⁾	MAX	UNIT
r _{on}	ON-state switch resistance ⁽²⁾	See Figure 7-1 and Figure 6-1	V _I = 0 V, I _O = 4 mA	1.65 V	11	20	Ω	
			V _I = 1.65 V, I _O = -4 mA		15	50		
			V _I = 0 V, I _O = 8 mA	2.3 V	8	12		
			V _I = 2.3 V, I _O = -8 mA		11	30		
			V _I = 0 V, I _O = 24 mA	3 V	7	9.5		
			V _I = 3 V, I _O = -24 mA		9	20		
			V _I = 0 V, I _O = 30 mA	4.5 V	6	7.5		
			V _I = 2.4 V, I _O = -30 mA		7	12		
			V _I = 4.5 V, I _O = -30 mA		7	15		
r _{range}	ON-state switch resistance over signal range ^{(2) (3)}	0 ≤ V _{Bn} ≤ V _{CC} (see Figure 7-1 and Figure 6-1)	I _A = -4 mA	1.65 V		140	Ω	
			I _A = -8 mA	2.3 V		45		
			I _A = -24 mA	3 V		18		
			I _A = -30 mA	4.5 V		10		
Δr _{on}	Difference in on-state resistance between switches ^{(2) (4) (5)}	See Figure 7-1	V _{Bn} = 1.15 V, I _A = -4 mA	1.65 V	0.5	Ω		
			V _{Bn} = 1.6 V, I _A = -8 mA	2.3 V	0.1			
			V _{Bn} = 2.1 V, I _A = -24 mA	3 V	0.1			
			V _{Bn} = 3.15 V, I _A = -30 mA	4.5 V	0.1			
r _{on(flat)}	ON-state resistance flatness ^{(2) (4) (6)}	0 ≤ V _{Bn} ≤ V _{CC}	I _A = -4 mA	1.65 V	110	Ω		
			I _A = -8 mA	2.3 V	26			
			I _A = -24 mA	3 V	9			
			I _A = -30 mA	4.5 V	4			
I _{off} ⁽⁷⁾	OFF-state switch leakage current	0 ≤ V _I , V _O ≤ V _{CC} (see Figure 7-2)	1.65 V to 5.5 V		±1 ±0.05	±1 ⁽¹⁾	μA	
I _{S(on)}	ON-state switch leakage current	V _I = V _{CC} or GND, V _O = Open (see Figure 7-3)	5.5 V		±1 ±0.1 ⁽¹⁾		μA	
I _{IN}	Control input current	0 ≤ V _{IN} ≤ V _{CC}	0 V to 5.5 V		±1 ±0.05	±1 ⁽¹⁾	μA	
I _{CC}	Supply current	V _{IN} = V _{CC} or GND	5.5 V	1	10		μA	
ΔI _{CC}	Supply-current change	V _{IN} = V _{CC} - 0.6 V	5.5 V		500		μA	
C _{in}	Control input capacitance	S	5 V	2.7			pF	
C _{io(off)}	Switch I/O capacitance	Bn	5 V	5.2			pF	
C _{io(on)}	Switch I/O capacitance	Bn	5 V	17.3			pF	
		A		17.3				

(1) T_A = 25°C

(2) Measured by the voltage drop between I/O pins at the indicated current through the switch. ON-state resistance is determined by the lower of the voltages on the two (A or B) ports.

(3) Specified by design

(4) Δr_{on} = r_{on(max)} - r_{on(min)} measured at identical V_{CC}, temperature, and voltage levels

(5) This parameter is characterized, but not tested in production.

(6) Flatness is defined as the difference between the maximum and minimum values of ON-state resistance over the specified range of conditions.

(7) I_{off} is the same as I_{S(off)} (OFF-state switch leakage current).

6.6 Switching Characteristics

over recommended operating free-air temperature range (unless otherwise noted) (see [Figure 7-4](#) and [Figure 7-10](#))

PARAMETER	FROM (INPUT)	TO (OUTPUT)	$V_{CC} = 1.8\text{ V} \pm 0.15\text{ V}$		$V_{CC} = 2.5\text{ V} \pm 0.2\text{ V}$		$V_{CC} = 3.3\text{ V} \pm 0.3\text{ V}$		$V_{CC} = 5\text{ V} \pm 0.5\text{ V}$		UNIT
			MIN	MAX	MIN	MAX	MIN	MAX	MIN	MAX	
$t_{pd}^{(1)}$	A or Bn	Bn or A	2		1.2		0.8		0.3		ns
$t_{en}^{(2)}$	S	Bn	7	24	3.5	14	2.5	7.6	1.7	5.7	ns
$t_{dis}^{(3)}$			3	13	2	7.5	1.5	5.3	0.8	3.8	
$t_{B-M}^{(4)}$			0.5		0.5		0.5		0.5		ns

- (1) t_{pd} is the slower of t_{PLH} or t_{PHL} . Propagation delay is the calculated RC time constant of the typical ON-state resistance of the switch and the specified load capacitance when driven by an ideal voltage source (zero output impedance).
- (2) t_{en} is the slower of t_{PZL} or t_{PHZ} .
- (3) t_{dis} is the slower of t_{PLZ} or t_{PHZ} .
- (4) Specified by design

6.7 Analog Switch Characteristics

$T_A = 25^\circ\text{C}$

PARAMETER	FROM (INPUT)	TO (OUTPUT)	TEST CONDITIONS	V_{CC}	TYP	UNIT
Frequency response (switch on) ⁽¹⁾	A or Bn	Bn or A	$R_L = 50\ \Omega$, $f_{in} = \text{sine wave}$ (see Figure 7-5)	1.65 V	300	MHz
				2.3 V	300	
				3 V	300	
				4.5 V	300	
Crosstalk (between switches) ⁽²⁾	B1 or B2	B2 or B1	$R_L = 50\ \Omega$, $f_{in} = 10\text{ MHz (sine wave)}$ (see Figure 7-6)	1.65 V	-54	dB
				2.3 V	-54	
				3 V	-54	
				4.5 V	-54	
Feedthrough attenuation (switch off) ⁽²⁾	A or Bn	Bn or A	$C_L = 5\text{ pF}$, $R_L = 50\ \Omega$, $f_{in} = 10\text{ MHz (sine wave)}$ (see Figure 7-7)	1.65 V	-57	dB
				2.3 V	-57	
				3 V	-57	
				4.5 V	-57	
Charge injection ⁽³⁾	S	A	$C_L = 0.1\text{ nF}$, $R_L = 1\text{ M}\Omega$ (see Figure 7-8)	3.3 V	3	pC
				5 V	7	
Total harmonic distortion	A or Bn	Bn or A	$V_I = 0.5\text{ Vp-p}$, $R_L = 600\ \Omega$, $f_{in} = 600\text{ Hz to }20\text{ kHz}$ (sine wave) (see Figure 7-9)	1.65%	0.1%	V
				2.3%	0.025%	
				3%	0.015%	
				4.5%	0.01%	

- (1) Adjust f_{in} voltage to obtain 0 dBm at output. Increase f_{in} frequency until dB meter reads -3 dB.
- (2) Adjust f_{in} voltage to obtain 0 dBm at input.
- (3) Specified by design

6.8 Typical Characteristics

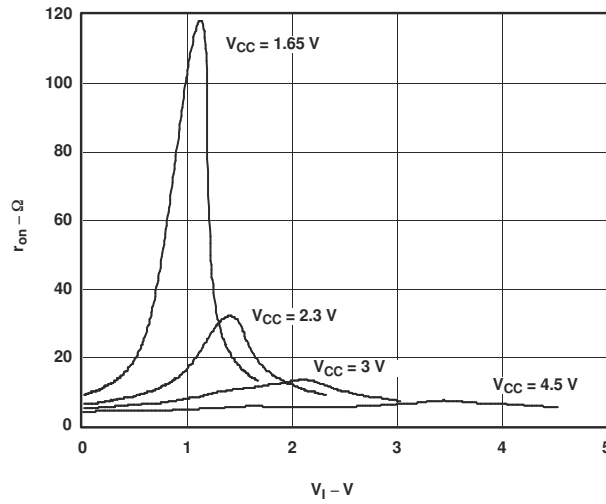

Figure 6-1. Typical R_{on} as a Function of Input Voltage (V_i) for $V_i = 0$ To V_{CC}

7 Parameter Measurement Information

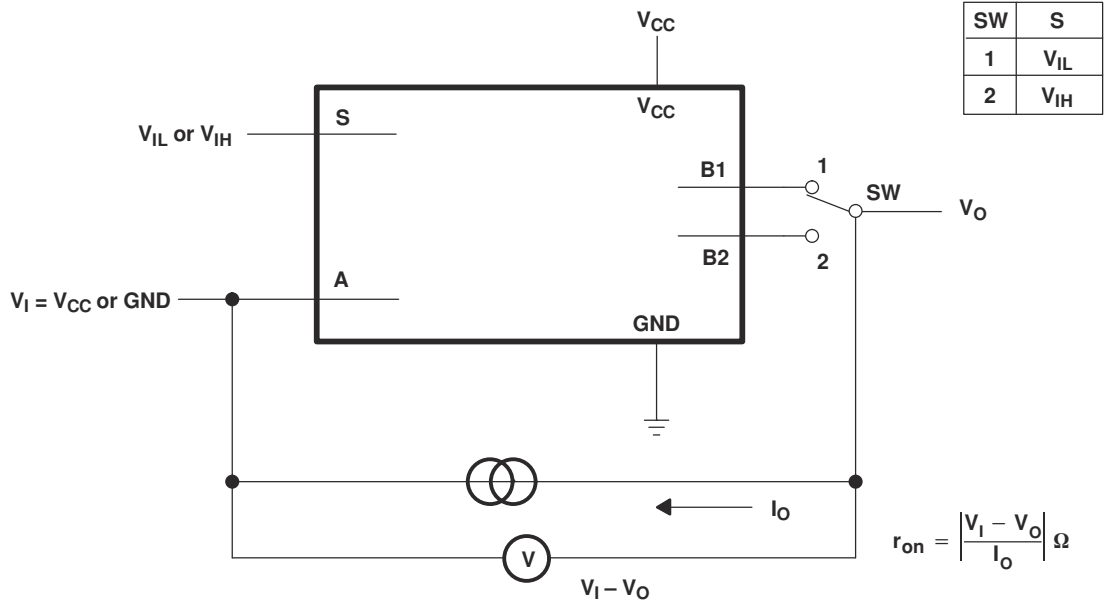
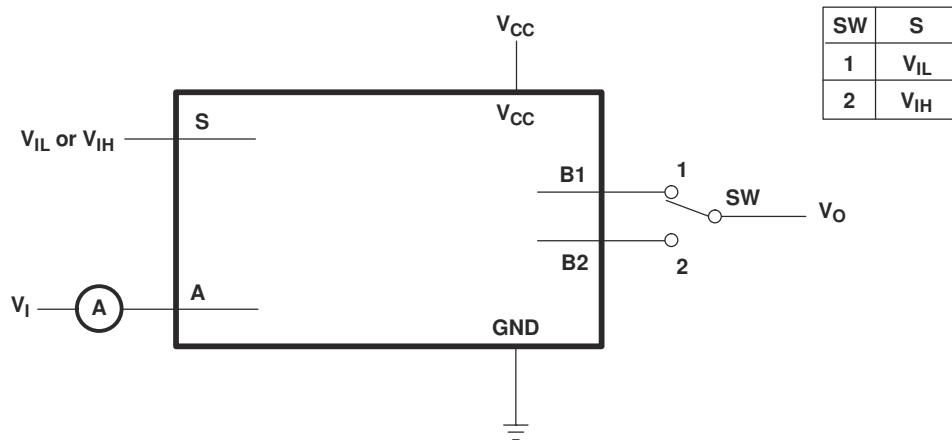

Figure 7-1. ON-State Resistance Test Circuit



Condition 1: V_I = GND, V_O = V_{CC}
 Condition 2: V_I = V_{CC}, V_O = GND

Figure 7-2. OFF-State Switch Leakage-Current Test Circuit

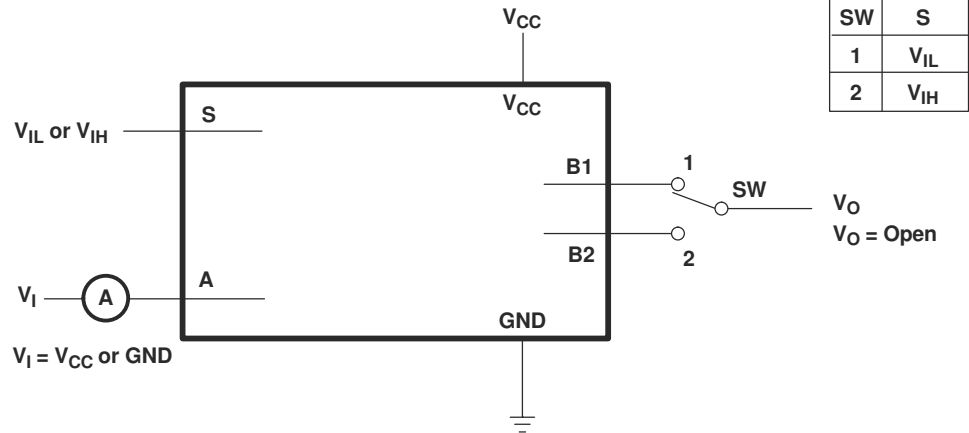
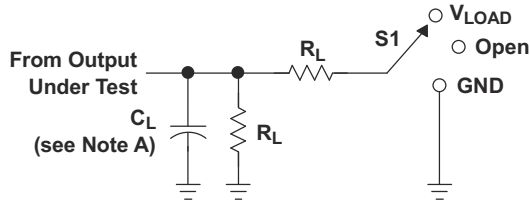

Figure 7-3. ON-State Switch Leakage-Current Test Circuit



LOAD CIRCUIT

TEST	S1
t_{PLH}/t_{PHL}	Open
t_{PLZ}/t_{PZL}	V_{LOAD}
t_{PHZ}/t_{PZH}	GND

V_{CC}	INPUTS		V_M	V_{LOAD}	C_L	R_L	V_{Δ}
	V_I	t_r/t_f					
$1.8\text{ V} \pm 0.15\text{ V}$	V_{CC}	$\leq 2\text{ ns}$	$V_{CC}/2$	$2 \times V_{CC}$	50 pF	500 Ω	0.3 V
$2.5\text{ V} \pm 0.2\text{ V}$	V_{CC}	$\leq 2\text{ ns}$	$V_{CC}/2$	$2 \times V_{CC}$	50 pF	500 Ω	0.3 V
$3.3\text{ V} \pm 0.3\text{ V}$	V_{CC}	$\leq 2.5\text{ ns}$	$V_{CC}/2$	$2 \times V_{CC}$	50 pF	500 Ω	0.3 V
$5\text{ V} \pm 0.5\text{ V}$	V_{CC}	$\leq 2.5\text{ ns}$	$V_{CC}/2$	$2 \times V_{CC}$	50 pF	500 Ω	0.3 V

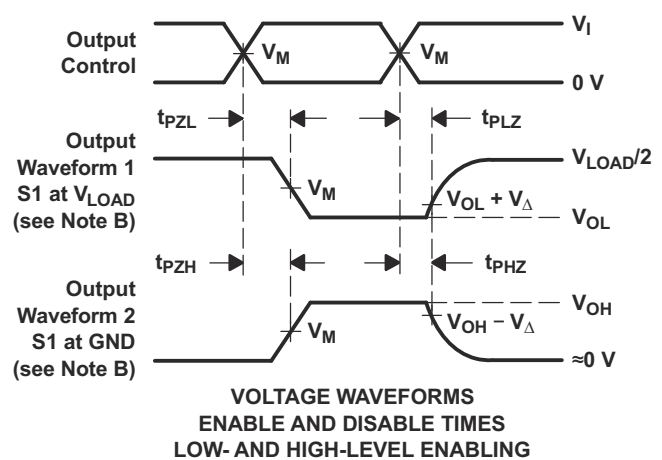
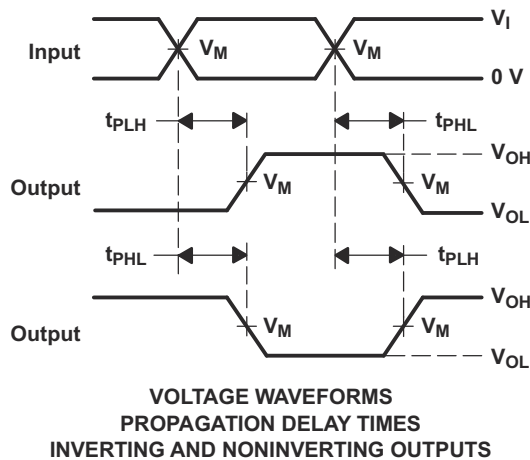
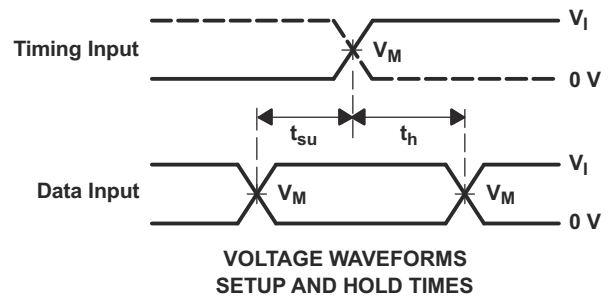
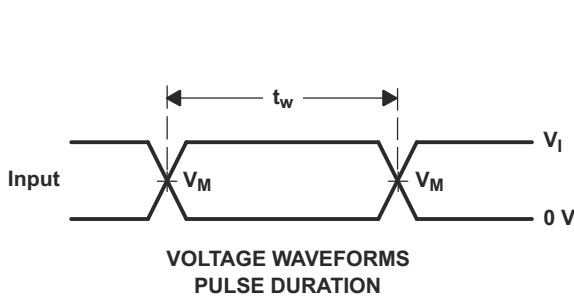

- NOTES:
- C_L includes probe and jig capacitance.
 - Waveform 1 is for an output with internal conditions such that the output is low except when disabled by the output control. Waveform 2 is for an output with internal conditions such that the output is high, except when disabled by the output control.
 - All input pulses are supplied by generators having the following characteristics: PRR $\leq 10\text{-MHz}$, $Z_O = 50\ \Omega$.
 - The outputs are measured one at a time, with one transition per measurement.
 - t_{PLZ} and t_{PHZ} are the same as t_{dis} .
 - t_{PZL} and t_{PZH} are the same as t_{en} .
 - t_{PLH} and t_{PHL} are the same as t_{pd} .
 - All parameters and waveforms are not applicable to all devices.

Figure 7-4. Load Circuit and Voltage Waveforms

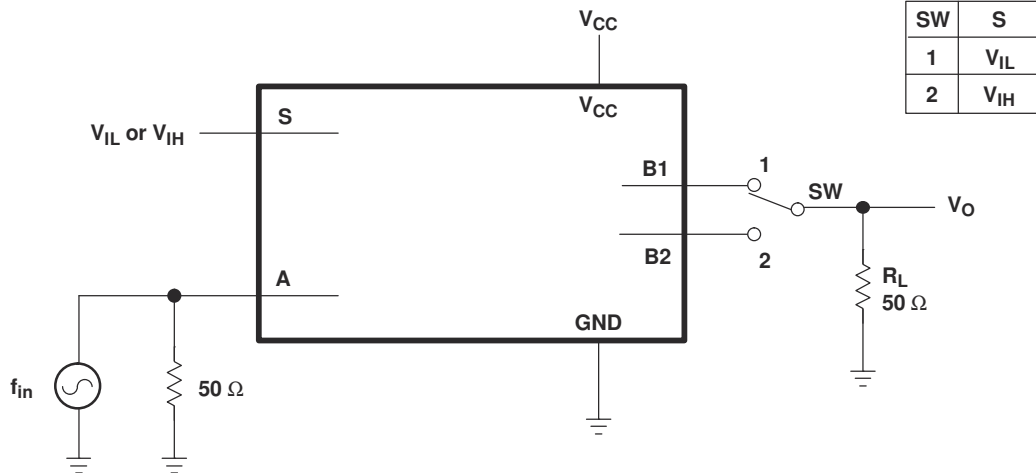

Figure 7-5. Frequency Response (Switch On)

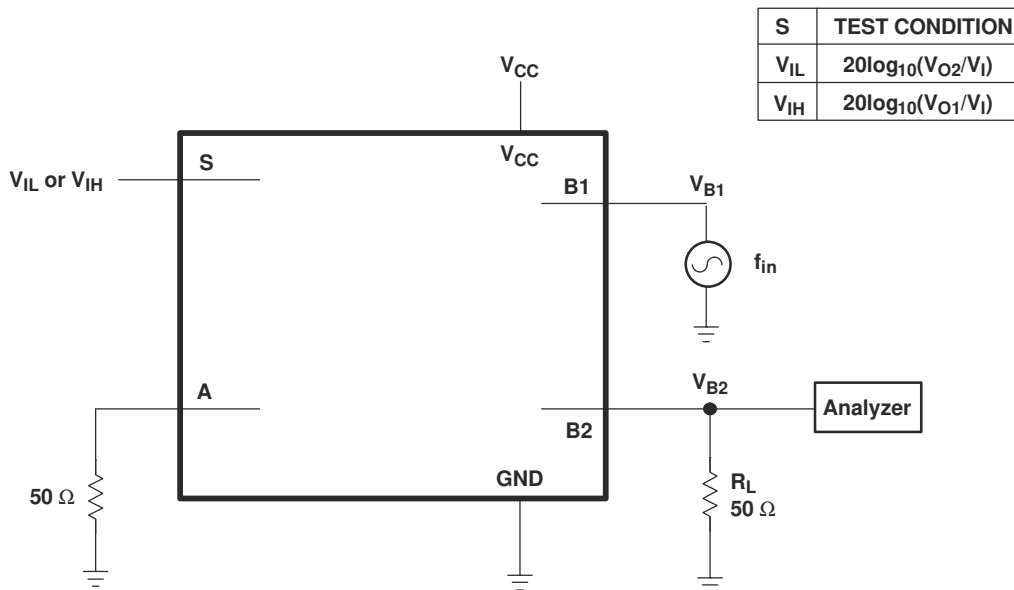

Figure 7-6. Crosstalk (Between Switches)

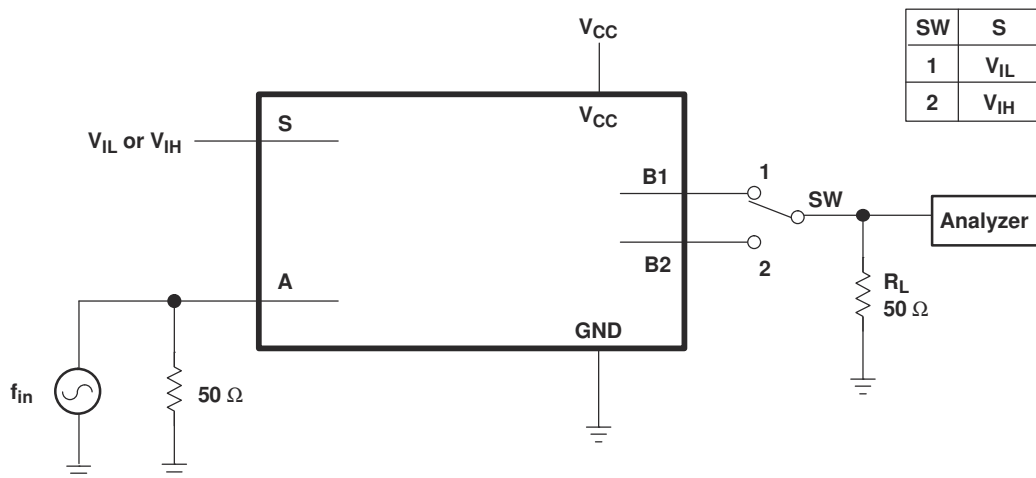

Figure 7-7. Feedthrough

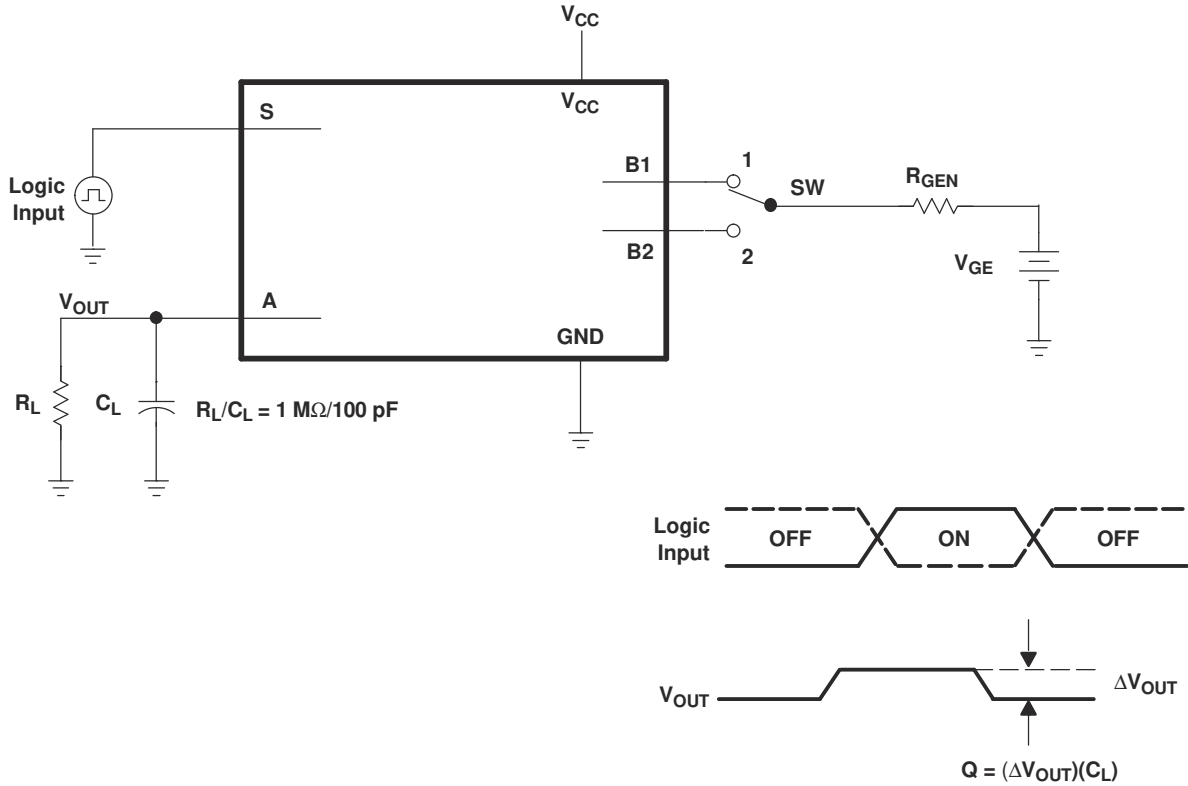

Figure 7-8. Charge-Injection Test

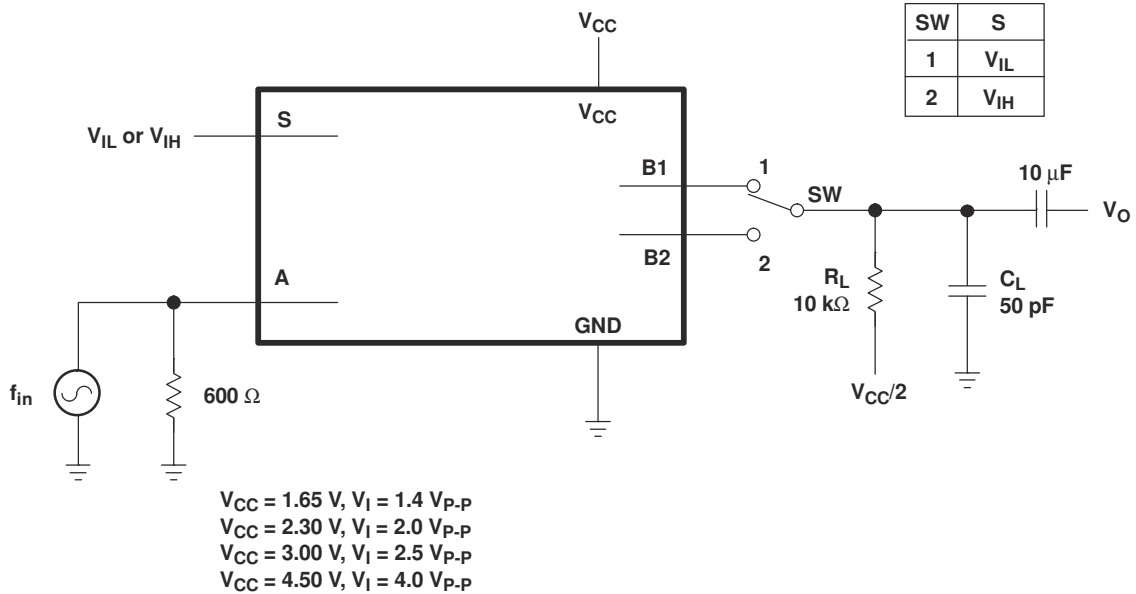

Figure 7-9. Total Harmonic Distortion

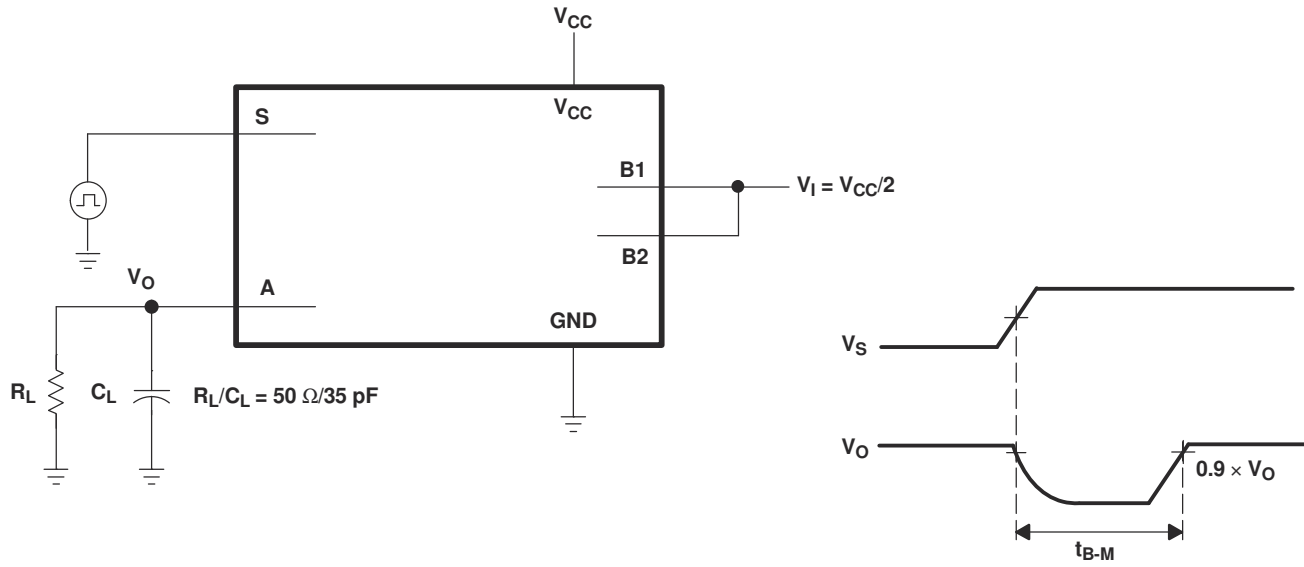

Figure 7-10. Break-Before-Make Internal Timing

8 Detailed Description

8.1 Overview

The SN74LVC1G3157-Q1 device is a single-pole double-throw (SPDT) analog switch designed for 1.65-V to 5.5-V

V_{CC} operation. The SN74LVC1G3157-Q1 device can handle analog and digital signals. The device permits signals with amplitudes of up to V_{CC} (peak) to be transmitted in either direction.

8.2 Functional Block Diagram

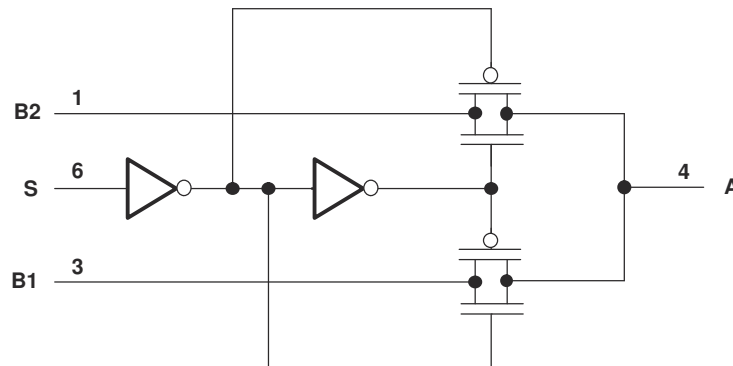

Figure 8-1. Logic Diagram (Positive Logic)

8.3 Feature Description

These devices are qualified for automotive applications. The 1.65-V to 5.5-V supply operation allows the device to function in many different systems comprised of different logic levels, allowing rail-to-rail signal switching. Either the B1 channel or the B2 channel is activated depending upon the control input. If the control input is low, B1 channel is selected. If the control input is high, B2 channel is selected.

8.4 Device Functional Modes

Table 8-1 lists the ON channel when one of the control inputs is selected.

Table 8-1. Function Table

CONTROL INPUTS	ON CHANNEL
L	B1
H	B2

9 Application and Implementation

Note

Information in the following applications sections is not part of the TI component specification, and TI does not warrant its accuracy or completeness. TI's customers are responsible for determining suitability of components for their purposes, as well as validating and testing their design implementation to confirm system functionality.

9.1 Application Information

The SN74LVC1G3157-Q1 SPDT analog switch is flexible enough for use in a variety of circuits such as analog audio routing, power-up monitor, memory sharing and so on. For details on the applications, you can also view [SCYB014](#).

9.2 Typical Application

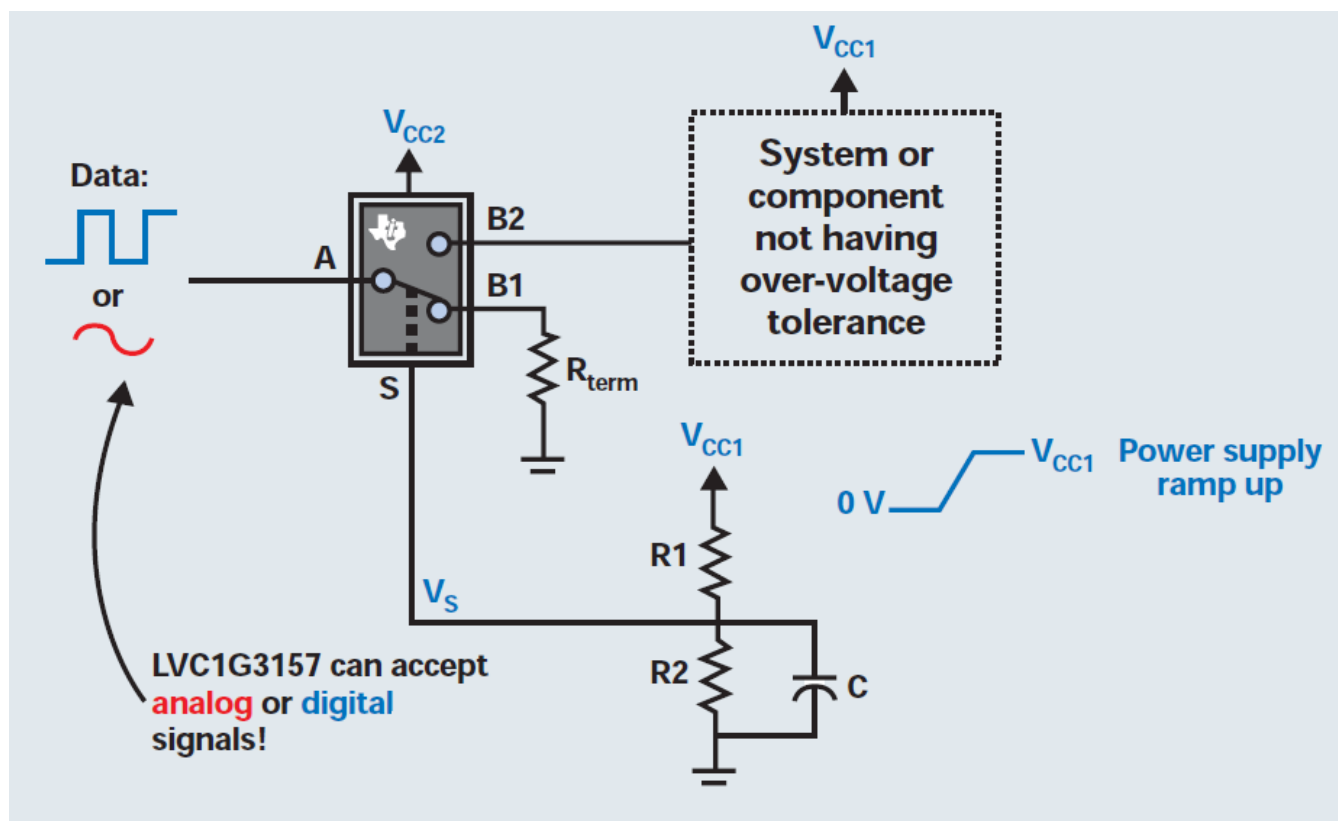

Figure 9-1. Typical Application Schematic

9.2.1 Design Requirements

The inputs can be analog or digital, but TI recommends waiting until VCC has ramped to a level in [Section 6.3](#) before applying any signals. Appropriate termination resistors should be used depending on the type of signal and specification. The Select pin should not be left floating; either pull up or pull down with a resistor that can be overdriven by a GPIO.

9.2.2 Detailed Design Procedure

Using this circuit idea, a system designer can ensure a component or subsystem power has ramped up before allowing signals to be applied to its input. This is useful for integrated circuits that do not have overvoltage tolerant inputs. The basic idea uses a resistor divider on the VCC1 power rail, which is ramping up. The RC time constant of the resistor divider further delays the voltage ramp on the select pin of the SPDT bus switch. By carefully selecting values for R1, R2 and C, it is possible to ensure that VCC1 will reach its nominal value before the path from A to B2 is established, thus preventing a signal being present on an I/O before the device/system is powered up. To ensure the minimum desired delay is achieved, the designer should use Equation 1 to calculate the time required from a transition from ground (0 V) to half the supply voltage (VCC1/2).

$$\text{Set} \left(\frac{R2}{R1 + R2} \times V_{CC1} > V_{IH} \right) \text{ of the select pin} \tag{1}$$

Choose Rs and C to achieve the desired delay.

When Vs goes high, the signal will be passed.

9.2.3 Application Curve

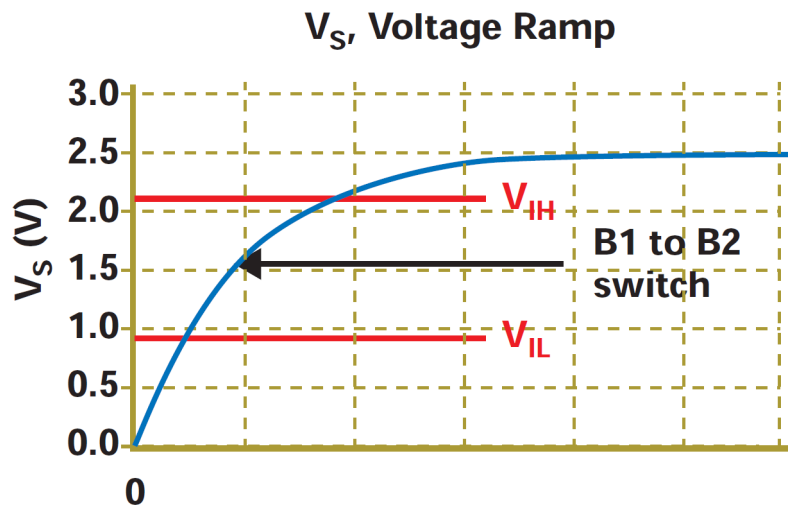

Figure 9-2. V_S Voltage Ramp

10 Power Supply Recommendations

Most systems have a common 3.3-V or 5-V rail that can supply the V_{CC} pin of this device. If this is not available, a Switch-Mode-Power-Supply (SMPS) or a Linear Dropout Regulator (LDO) can be used to provide supply to this device from another voltage rail.

11 Layout

11.1 Layout Guidelines

TI recommends keeping signal lines as short as possible. TI also recommends incorporating microstrip or stripline techniques when signal lines are greater than 1 inch in length. These traces must be designed with a characteristic impedance of either $50\ \Omega$ or $75\ \Omega$, as required by the application. Do not place this device too close to high-voltage switching components, as they may interfere with the device.

11.2 Layout Example

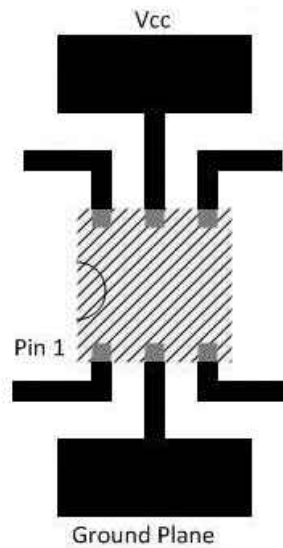

Figure 11-1. Recommended Layout Example

12 Device and Documentation Support

12.1 Documentation Support

12.1.1 Related Documentation

For related documentation, see the following:

- Texas Instruments, [SN74LVC1G3157 and SN74LVC2G53 SPDT Analog Switches product overview](#)
- Texas Instruments, [SN74LVC1G3157-Q1 Functional Safety, FIT Rate, FMD, and Pin FMA report](#)

12.2 Receiving Notification of Documentation Updates

To receive notification of documentation updates, navigate to the device product folder on [ti.com](#). Click on *Subscribe to updates* to register and receive a weekly digest of any product information that has changed. For change details, review the revision history included in any revised document.

12.3 Support Resources

[TI E2E™ support forums](#) are an engineer's go-to source for fast, verified answers and design help — straight from the experts. Search existing answers or ask your own question to get the quick design help you need.

Linked content is provided "AS IS" by the respective contributors. They do not constitute TI specifications and do not necessarily reflect TI's views; see TI's [Terms of Use](#).

12.4 Trademarks

TI E2E™ is a trademark of Texas Instruments.

All trademarks are the property of their respective owners.

12.5 Electrostatic Discharge Caution



This integrated circuit can be damaged by ESD. Texas Instruments recommends that all integrated circuits be handled with appropriate precautions. Failure to observe proper handling and installation procedures can cause damage.

ESD damage can range from subtle performance degradation to complete device failure. Precision integrated circuits may be more susceptible to damage because very small parametric changes could cause the device not to meet its published specifications.

12.6 Glossary

[TI Glossary](#) This glossary lists and explains terms, acronyms, and definitions.

13 Mechanical, Packaging, and Orderable Information

The following pages include mechanical, packaging, and orderable information. This information is the most current data available for the designated devices. This data is subject to change without notice and revision of this document. For browser-based versions of this data sheet, refer to the left-hand navigation.

PACKAGING INFORMATION

Orderable Device	Status (1)	Package Type	Package Drawing	Pins	Package Qty	Eco Plan (2)	Lead finish/ Ball material (6)	MSL Peak Temp (3)	Op Temp (°C)	Device Marking (4/5)	Samples
1P1G3157QDBVRQ1	ACTIVE	SOT-23	DBV	6	3000	RoHS & Green	NIPDAU	Level-1-260C-UNLIM	-40 to 125	CC5O	Samples
1P1G3157QDCKRQ1	ACTIVE	SC70	DCK	6	3000	RoHS & Green	NIPDAU SN	Level-1-260C-UNLIM	-40 to 125	(C5J, C5O)	Samples

(1) The marketing status values are defined as follows:

ACTIVE: Product device recommended for new designs.

LIFEBUY: TI has announced that the device will be discontinued, and a lifetime-buy period is in effect.

NRND: Not recommended for new designs. Device is in production to support existing customers, but TI does not recommend using this part in a new design.

PREVIEW: Device has been announced but is not in production. Samples may or may not be available.

OBSOLETE: TI has discontinued the production of the device.

(2) **RoHS:** TI defines "RoHS" to mean semiconductor products that are compliant with the current EU RoHS requirements for all 10 RoHS substances, including the requirement that RoHS substance do not exceed 0.1% by weight in homogeneous materials. Where designed to be soldered at high temperatures, "RoHS" products are suitable for use in specified lead-free processes. TI may reference these types of products as "Pb-Free".

RoHS Exempt: TI defines "RoHS Exempt" to mean products that contain lead but are compliant with EU RoHS pursuant to a specific EU RoHS exemption.

Green: TI defines "Green" to mean the content of Chlorine (Cl) and Bromine (Br) based flame retardants meet JS709B low halogen requirements of <=1000ppm threshold. Antimony trioxide based flame retardants must also meet the <=1000ppm threshold requirement.

(3) MSL, Peak Temp. - The Moisture Sensitivity Level rating according to the JEDEC industry standard classifications, and peak solder temperature.

(4) There may be additional marking, which relates to the logo, the lot trace code information, or the environmental category on the device.

(5) Multiple Device Markings will be inside parentheses. Only one Device Marking contained in parentheses and separated by a "~" will appear on a device. If a line is indented then it is a continuation of the previous line and the two combined represent the entire Device Marking for that device.

(6) Lead finish/Ball material - Orderable Devices may have multiple material finish options. Finish options are separated by a vertical ruled line. Lead finish/Ball material values may wrap to two lines if the finish value exceeds the maximum column width.

Important Information and Disclaimer:The information provided on this page represents TI's knowledge and belief as of the date that it is provided. TI bases its knowledge and belief on information provided by third parties, and makes no representation or warranty as to the accuracy of such information. Efforts are underway to better integrate information from third parties. TI has taken and continues to take reasonable steps to provide representative and accurate information but may not have conducted destructive testing or chemical analysis on incoming materials and chemicals. TI and TI suppliers consider certain information to be proprietary, and thus CAS numbers and other limited information may not be available for release.

In no event shall TI's liability arising out of such information exceed the total purchase price of the TI part(s) at issue in this document sold by TI to Customer on an annual basis.

OTHER QUALIFIED VERSIONS OF SN74LVC1G3157-Q1 :

- Catalog : [SN74LVC1G3157](#)

NOTE: Qualified Version Definitions:

- Catalog - TI's standard catalog product

TAPE AND REEL INFORMATION

QUADRANT ASSIGNMENTS FOR PIN 1 ORIENTATION IN TAPE

*All dimensions are nominal

Device	Package Type	Package Drawing	Pins	SPQ	Reel Diameter (mm)	Reel Width W1 (mm)	A0 (mm)	B0 (mm)	K0 (mm)	P1 (mm)	W (mm)	Pin1 Quadrant
1P1G3157QDBVRQ1	SOT-23	DBV	6	3000	179.0	8.4	3.2	3.2	1.4	4.0	8.0	Q3
1P1G3157QDCKRQ1	SC70	DCK	6	3000	178.0	9.0	2.4	2.5	1.2	4.0	8.0	Q3
1P1G3157QDCKRQ1	SC70	DCK	6	3000	179.0	8.4	2.2	2.5	1.2	4.0	8.0	Q3

TAPE AND REEL BOX DIMENSIONS

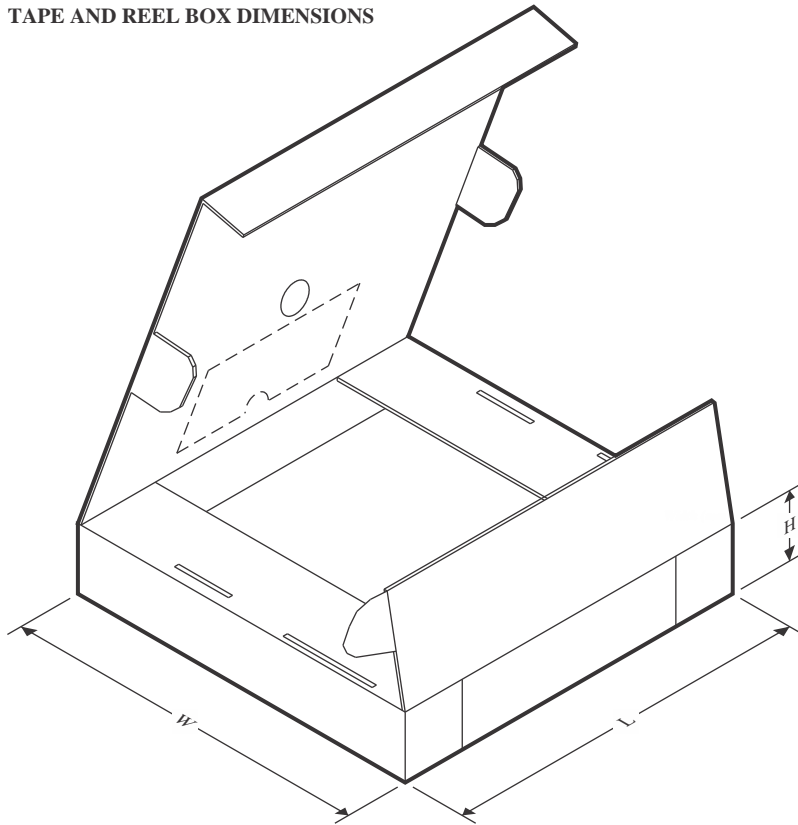

*All dimensions are nominal

Device	Package Type	Package Drawing	Pins	SPQ	Length (mm)	Width (mm)	Height (mm)
1P1G3157QDBVRQ1	SOT-23	DBV	6	3000	200.0	183.0	25.0
1P1G3157QDCKRQ1	SC70	DCK	6	3000	180.0	180.0	18.0
1P1G3157QDCKRQ1	SC70	DCK	6	3000	200.0	183.0	25.0

DBV0006A



PACKAGE OUTLINE

SOT-23 - 1.45 mm max height

SMALL OUTLINE TRANSISTOR

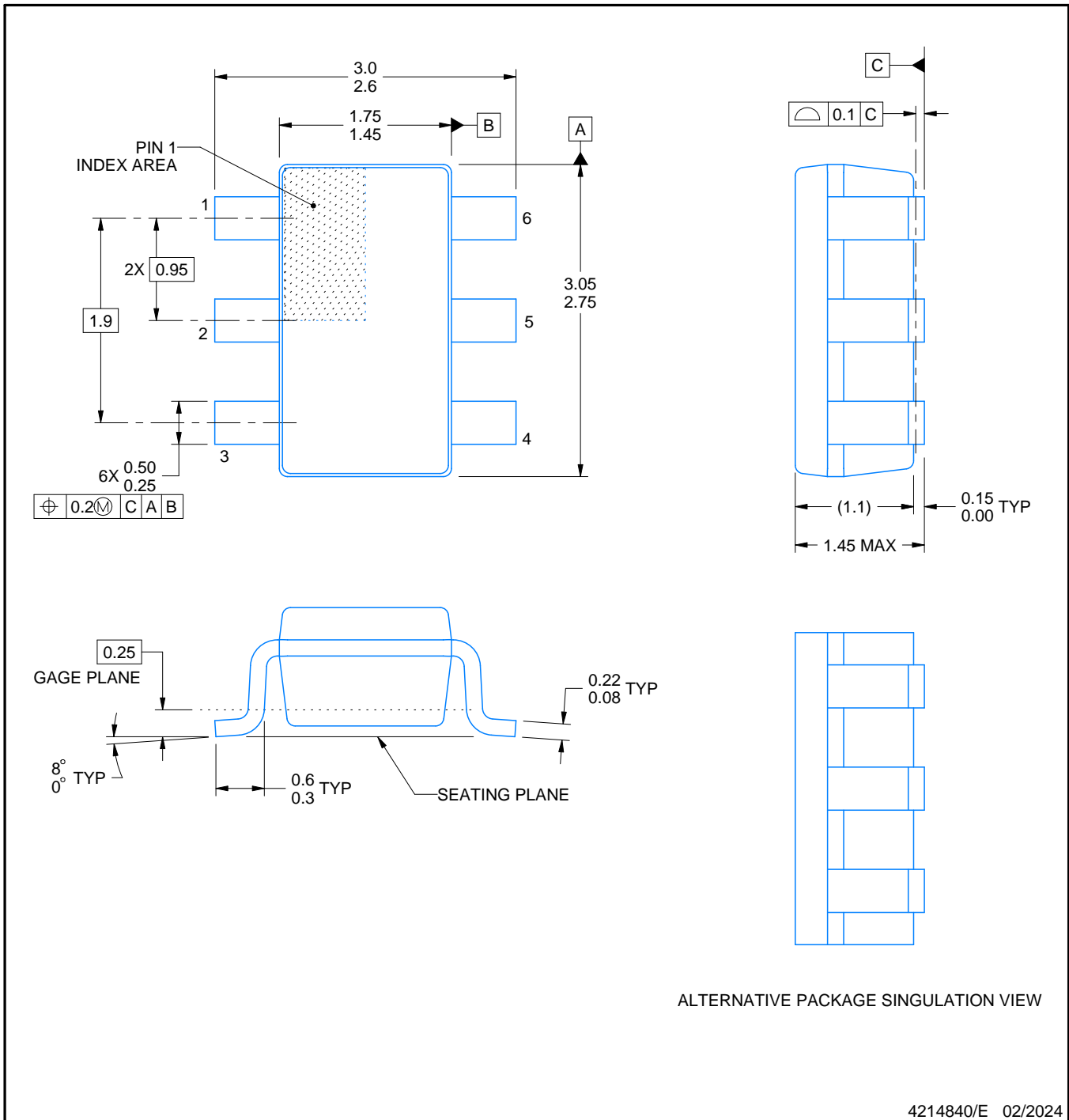

ALTERNATIVE PACKAGE SINGULATION VIEW

4214840/E 02/2024

NOTES:

1. All linear dimensions are in millimeters. Any dimensions in parenthesis are for reference only. Dimensioning and tolerancing per ASME Y14.5M.
2. This drawing is subject to change without notice.
3. Body dimensions do not include mold flash or protrusion. Mold flash and protrusion shall not exceed 0.25 per side.
4. Leads 1,2,3 may be wider than leads 4,5,6 for package orientation.
5. Reference JEDEC MO-178.

EXAMPLE BOARD LAYOUT

DBV0006A

SOT-23 - 1.45 mm max height

SMALL OUTLINE TRANSISTOR

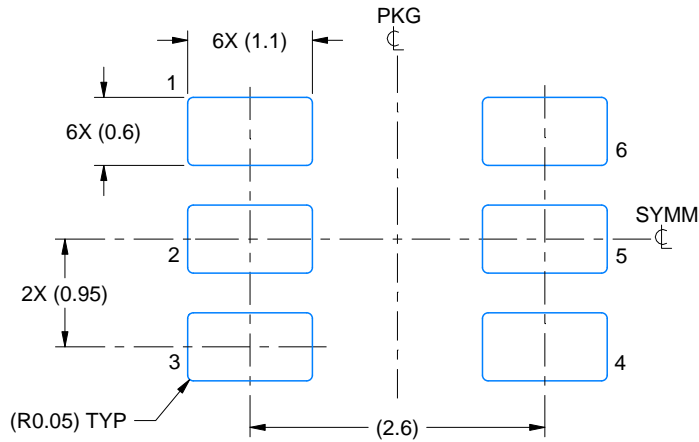

LAND PATTERN EXAMPLE
EXPOSED METAL SHOWN
SCALE:15X

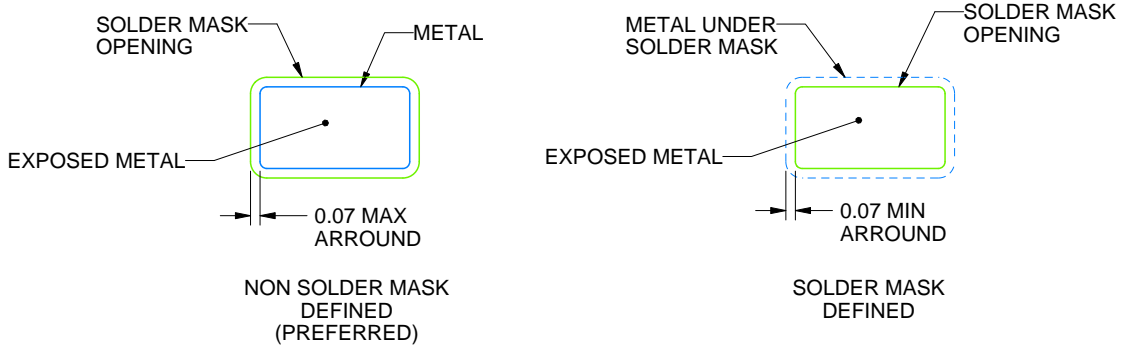

SOLDER MASK DETAILS

4214840/E 02/2024

NOTES: (continued)

- 6. Publication IPC-7351 may have alternate designs.
- 7. Solder mask tolerances between and around signal pads can vary based on board fabrication site.

EXAMPLE STENCIL DESIGN

DBV0006A

SOT-23 - 1.45 mm max height

SMALL OUTLINE TRANSISTOR

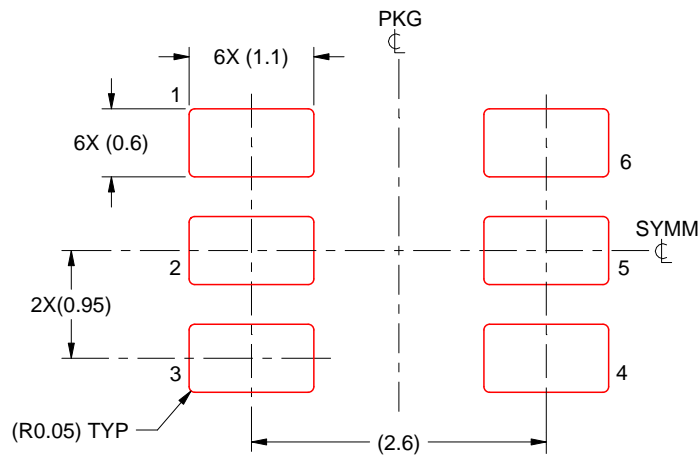

SOLDER PASTE EXAMPLE
BASED ON 0.125 mm THICK STENCIL
SCALE:15X

4214840/E 02/2024

NOTES: (continued)

8. Laser cutting apertures with trapezoidal walls and rounded corners may offer better paste release. IPC-7525 may have alternate design recommendations.
9. Board assembly site may have different recommendations for stencil design.

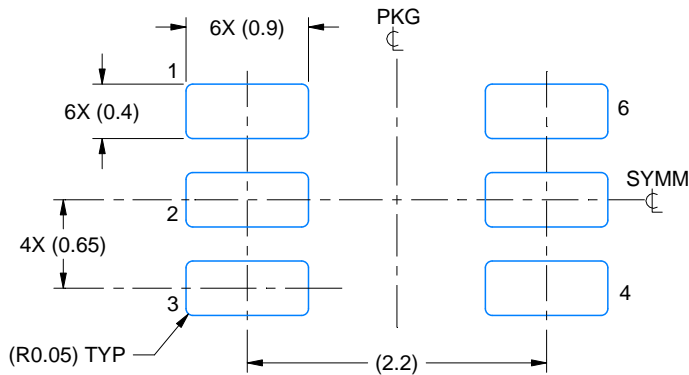

LAND PATTERN EXAMPLE
EXPOSED METAL SHOWN
SCALE:18X

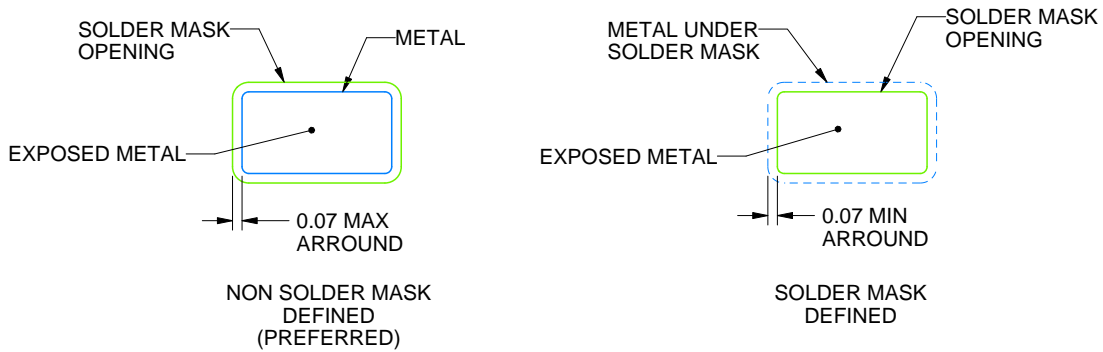

SOLDER MASK DETAILS

4214835/B 04/2024

NOTES: (continued)

5. Publication IPC-7351 may have alternate designs.
6. Solder mask tolerances between and around signal pads can vary based on board fabrication site.

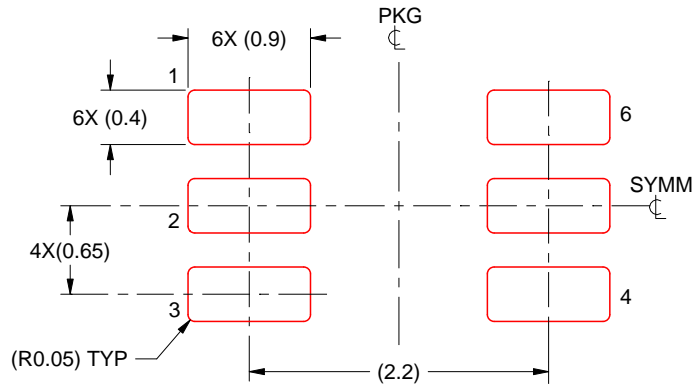

SOLDER PASTE EXAMPLE
BASED ON 0.125 THICK STENCIL
SCALE:18X

4214835/B 04/2024

NOTES: (continued)

7. Laser cutting apertures with trapezoidal walls and rounded corners may offer better paste release. IPC-7525 may have alternate design recommendations.
8. Board assembly site may have different recommendations for stencil design.

IMPORTANT NOTICE AND DISCLAIMER

TI PROVIDES TECHNICAL AND RELIABILITY DATA (INCLUDING DATA SHEETS), DESIGN RESOURCES (INCLUDING REFERENCE DESIGNS), APPLICATION OR OTHER DESIGN ADVICE, WEB TOOLS, SAFETY INFORMATION, AND OTHER RESOURCES "AS IS" AND WITH ALL FAULTS, AND DISCLAIMS ALL WARRANTIES, EXPRESS AND IMPLIED, INCLUDING WITHOUT LIMITATION ANY IMPLIED WARRANTIES OF MERCHANTABILITY, FITNESS FOR A PARTICULAR PURPOSE OR NON-INFRINGEMENT OF THIRD PARTY INTELLECTUAL PROPERTY RIGHTS.

These resources are intended for skilled developers designing with TI products. You are solely responsible for (1) selecting the appropriate TI products for your application, (2) designing, validating and testing your application, and (3) ensuring your application meets applicable standards, and any other safety, security, regulatory or other requirements.

These resources are subject to change without notice. TI grants you permission to use these resources only for development of an application that uses the TI products described in the resource. Other reproduction and display of these resources is prohibited. No license is granted to any other TI intellectual property right or to any third party intellectual property right. TI disclaims responsibility for, and you will fully indemnify TI and its representatives against, any claims, damages, costs, losses, and liabilities arising out of your use of these resources.

TI's products are provided subject to [TI's Terms of Sale](#) or other applicable terms available either on [ti.com](https://www.ti.com) or provided in conjunction with such TI products. TI's provision of these resources does not expand or otherwise alter TI's applicable warranties or warranty disclaimers for TI products.

TI objects to and rejects any additional or different terms you may have proposed.

Mailing Address: Texas Instruments, Post Office Box 655303, Dallas, Texas 75265
Copyright © 2024, Texas Instruments Incorporated

Looking for pricing, stock, or lifecycle information?

Click below to explore more details on WIN SOURCE:

 [View 1P1G3157QDCKRQ1 on WIN SOURCE](#)

 [Texas Instruments](#) Information

Optimize Your Supply Chain with WIN SOURCE Solutions

-  Global Sourcing Solution
-  Obsolete Management
-  Cost Control Management
-  Shortage Management
-  Alternative Solution
-  Excess Inventory Management