



**THE DATASHEET OF**  
**G125-0010005**



# Customer Information Sheet

IF IN DOUBT - ASK

©

NOT TO SCALE

THIRD ANGLE PROJECTION

ALL DIMENSIONS IN mm

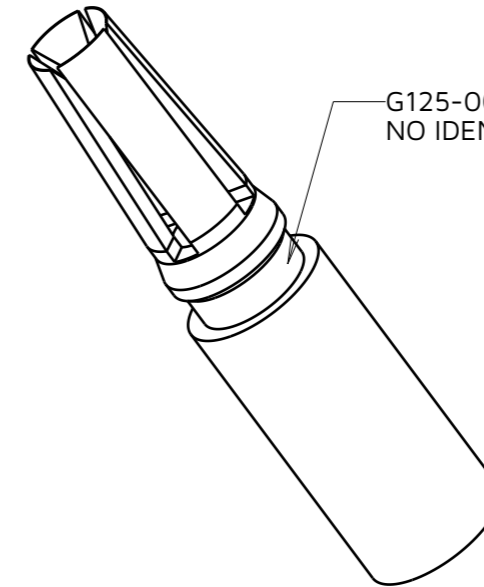

G125-0010005  
NO IDENT

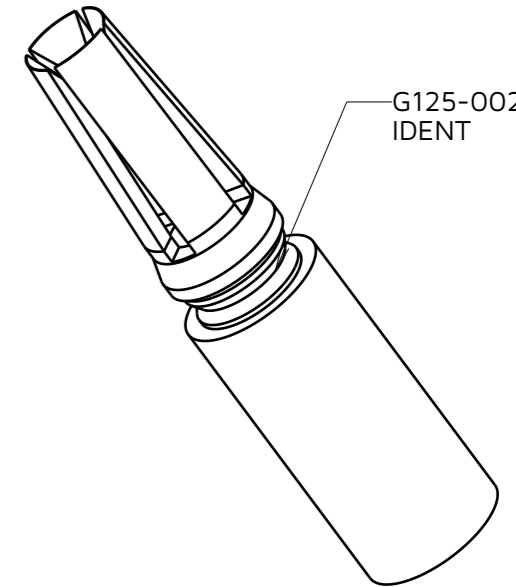

G125-0020005  
IDENT

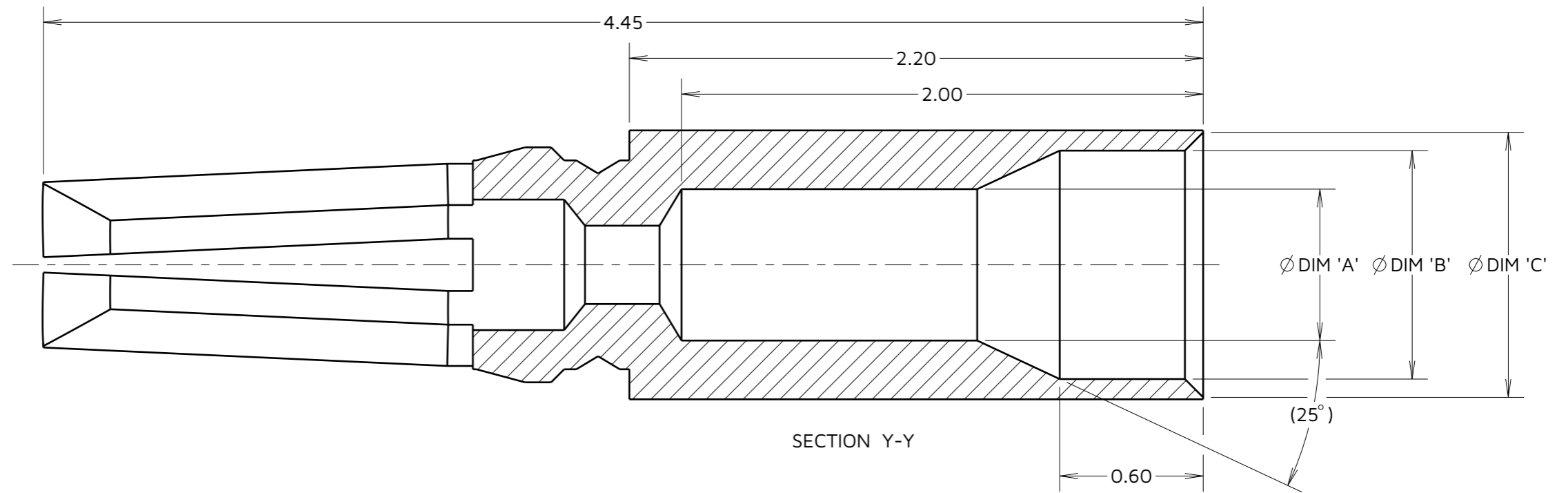
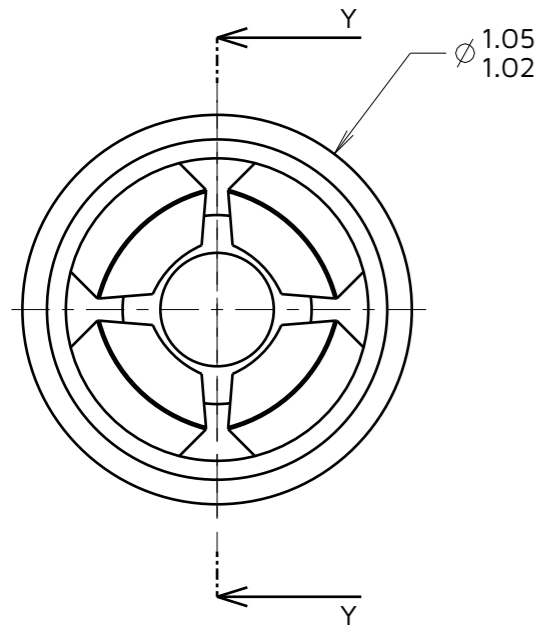

**NOTES:**

- G125-0010005 IS SUITABLE FOR WIRE GAUGE 26 AWG. MAXIMUM INSULATION DIAMETER  $\varnothing$  0.84mm, STRIP WIRE BY 1.50-1.75mm FOR CRIMPING.
- G125-0020005 IS SUITABLE FOR WIRE GAUGE 28-32 AWG. MAXIMUM INSULATION DIAMETER  $\varnothing$  0.74mm, STRIP WIRE BY 1.50-1.75mm FOR CRIMPING.
- RECOMMENDED CRIMP TOOL = Z125-900 & POSITIONER = Z125-901  
CONTACT INSERTION / WITHDRAWAL KIT = Z125-902.
- FOR INSTRUCTIONS ON HAND CRIMP TOOL Z125-900, SEE INSTRUCTION SHEET IS-37.
- FOR RECOMMENDED WIRE TYPES SEE COMPONENT SPECIFICATION C049XX (LATEST ISSUE).
- PACKING: 100 PER BOX.
- HANDLING GUIDLINES:  
WHEN HANDLING THIS PRODUCT WEAR NITRILE/LATEX POWDER FREE GLOVES OR FINGER COTS. TO PREVENT THE CONTAMINATION OF CONTACTS FROM HANDS.

TABLE 1: VARIANT DETAILS

PART No.	MATERIAL	FINISH	DIM 'A'	DIM 'B'	DIM 'C'	IDENT GROOVE
G125-0010005	BERYLLIUM COPPER	GOLD OVER NICKEL	$\varnothing$ 0.60	$\varnothing$ 0.88	$\varnothing$ 0.95	NO
			$\varnothing$ 0.55	$\varnothing$ 0.85	$\varnothing$ 0.92	
G125-0020005			$\varnothing$ 0.48	$\varnothing$ 0.80	$\varnothing$ 0.87	YES
			$\varnothing$ 0.44	$\varnothing$ 0.77	$\varnothing$ 0.84	

AY	15	04.07.24	34036
NAME	ISS.	DATE	CN/CO
APPROVED:		A.YEOMANS	
CHECKED:		R.PORTLOCK	
DRAWN:		S.FLOWER	
ASSEMBLY DRG:			

**HARWIN**

www.harwin.com

**TOLERANCES**  
 X. =  $\pm$ 1mm  
 X.X =  $\pm$ 0.50mm  
 X.XX =  $\pm$ 0.20mm  
 X.XXX =  $\pm$ 0.01mm  
 ANGLES =  $\pm$ 5°  
 UNLESS STATED

THIS DRAWING AND ANY INFORMATION OR DESCRIPTIVE MATTER SET OUT HEREON ARE CONFIDENTIAL AND COPYRIGHT PROPERTY OF THE HARWIN GROUP AND MUST NOT BE DISCLOSED, LOANED, COPIED OR USED FOR MANUFACTURING, TENDERING OR FOR ANY OTHER PURPOSE WITHOUT THEIR WRITTEN PERMISSION.

**MATERIAL:**  
SEE TABLE 1

**TITLE:**  
G125 SERIES FEMALE CRIMP SIGNAL CONTACTS

**DRAWING NUMBER:**  
G125-0010005, G125-0020005

SHT  
4  
OF  
4

## Looking for pricing, stock, or lifecycle information?

Click below to explore more details on WIN SOURCE:

 [View G125-0010005 on WIN SOURCE](#)

 [Harwin Inc. Information](#)

## Optimize Your Supply Chain with WIN SOURCE Solutions

-  Global Sourcing Solution
-  Obsolete Management
-  Cost Control Management
-  Shortage Management
-  Alternative Solution
-  Excess Inventory Management