



THE DATASHEET OF ECS60US15



ECS Series



GREEN XP POWER

- IT & Medical Safety Approvals
- Very Small 2"x 3"x 0.95" Package
- <0.3 W No Load Input Power
- 25, 45 & 60 W – Convection Cooled Ratings
- Class I & Class II Installations
- -20 °C to +70 °C Operation
- 3 Year Warranty

Specification

Input

Input Voltage	• 80-264 VAC (120-370 VDC), derate linearly from 100% at 90 VAC to 80% at 80 VAC
Input Frequency	• 47-63 Hz
Input Current	• 25 W: 0.45 A, 45 W: 0.75 A, 60 W: 0.95 A typical at 115 VAC, full load, 25 W: 0.30 A, 45 W: 0.45 A, 60 W: 0.60 A, typical at 230 VAC, full load
Inrush Current	• 40 A max at 230 VAC, cold start 25 °C
Power Factor	• EN61000-3-2, class A
No Load Input Power	• US05, 12 & 24 models: <0.3 W, US48 and all ECS60 models: <0.5 W
Earth Leakage Current	• 260 µA at 264 VAC/60 Hz max, 80/160 µA typical 115/230 VAC
Input Protection	• T3.15 A/250 V internal fuse in line and neutral

Output

Output Voltage	• 5-48 VDC (see tables)
Output Voltage Trim	• ±10%
Initial Set Accuracy	• ±1%
Minimum Load	• No minimum load required
Start Up Delay	• 1 s typical
Start Up Rise Time	• 50 ms
Hold Up Time	• 16 ms min at 115 VAC
Drift	• ±0.2% after 20 min warm up
Line Regulation	• ±0.5% max
Load Regulation	• ±1%
Over/Undershoot	• 5% typical
Transient Response	• 4% max. deviation, recovery to within 1% in 500 µs for a 50-75-50% load change
Ripple & Noise	• 1% pk-pk V1, 20 MHz bandwidth ⁽¹⁾
Overvoltage Protection	• 115-140% Vnom, recycle input to reset
Overload Protection	• 110-160%
Short Circuit Protection	• Continuous trip and restart (hiccup mode)
Temperature Coefficient	• 0.05%/°C

Notes

1. ECS60US12 1.5% pk-pk, 20 MHz bandwidth under certain line/load conditions.
2. See longform datasheet or contact sales for details.

General

Efficiency	• Up to 90%, model dependant
Isolation	• 4000 VAC In to Out, 2 x MOPP, 1500 VAC In to Earth, 1 x MOPP, 500 VDC Out to Earth, 1 x MOPP
Switching Frequency	• 65 KHz typical
Power Density	• Up to 7.9 W/in ³
MTBF	• 25 & 45 W: 1072 kHrs, 60 W: 471 kHrs to MIL-HDBK-217F at 25 °C, GB

Environmental

Operating Temperature	• -20 °C to +70 °C derate linearly from +50 °C at 2.5%/°C to 50% load at +70 °C.
Cooling	• Convection, see thermal considerations
Operating Humidity	• 95% RH, non-condensing
Storage Temperature	• -40 °C to +85 °C
Operating Altitude	• 3000 m
Shock	• 30 g pk, half sine, 6 axes
Vibration	• 2 g rms, 5 Hz to 500 Hz, 3 axes

EMC & Safety

Low Voltage PSU EMC Emissions	• EN61204-3, high severity level
	• All models: EN55011/32 level B conducted, 45 & 60 W: EN55011/32 level A radiated, ECS25 & ECS60US24/48 models: level B radiated
Harmonic Currents	• EN61000-3-2, class A
Voltage Flicker	• EN61000-3-3
Radiated Immunity	• EN61000-4-3, level 3 Perf Criteria A
EFT/Burst	• EN61000-4-4, level 3 Perf Criteria A
Surge	• EN61000-4-5, installation class 3 Perf Criteria A
Conducted Immunity	• EN61000-4-6, level 3 Perf Criteria A
Dips & Interruptions	• EN61000-4-11, 30% 10 ms, 60% 100 ms, 100% 5000 ms, Perf Criteria A, B, B, EN60601-1-2, 30% 500 ms, 60% 100 ms, 100% 10 ms, 100% 5000 ms, Perf Criteria A, A, A, B - 230 VAC. Consult longform datasheet for 115V operation.
Safety Approvals	• IEC60950-1:2005 Ed 2 / IEC62368-1:2014 UL 62368-1 & CAN/CSA C22.2 No. 62368-1-14, EN62368-1:2014/A11:2017, IEC60601-1 CB report, ANSI/AAMI ES60601-1, TUV 60601-1, Including Risk Management, CE & UKCA meets all applicable directives & legislation.
Equipment Protection Class	• Class I and Class II

Output Power	Output Voltage	Output Current	Model Number ⁽¹⁾
25 W	12.0VDC	2.08 A	ECS25US12
25 W	15.0VDC	1.67 A	ECS25US15
25 W	24.0VDC	1.04 A	ECS25US24
25 W	48.0VDC	0.52 A	ECS25US48

Notes

1. For covered versions, add suffix '-C' to model number or order part number ECS25-60 COVER KIT for standalone cover. Not suitable for use in class II installations, derate output power by 20% with cover.

Mechanical Details

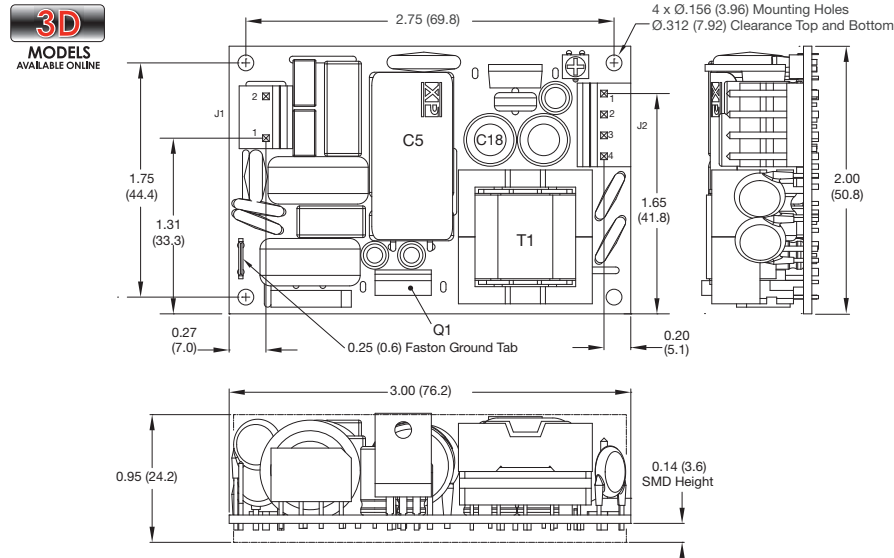

Input Connector J1 Molex PN 09-65-2038	
Pin 1	Line
Pin 2	Neutral
0.25" Faston	Earth

Output Connector J2 Molex PN 09-65-2048	
Pin 1	+V1
Pin 2	+V1
Pin 3	RTN
Pin 4	RTN

J1 mates with Molex Housing PN 09-50-1031, J2 mates with Molex Housing PN 09-50-1041 and both with Molex Series 5194 Crimp Terminals. Faston ground tab requires insulated receptacle.

Notes

- All dimensions in inches (mm). Tolerance .xx = ±0.02 (0.50); .xxx = ±0.01 (0.25)
- Weight 0.22 lbs (100 g)

Covered version (All ECS25-60 Models)

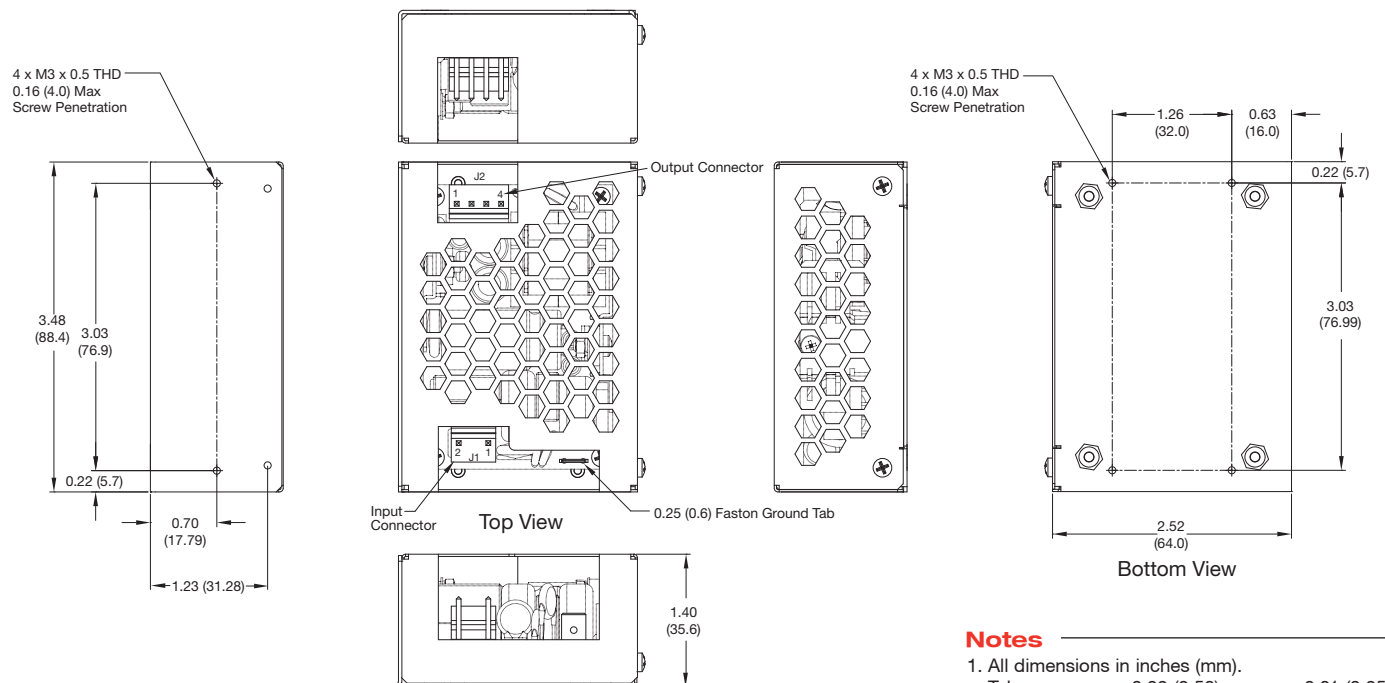

Notes

- All dimensions in inches (mm). Tolerance .xx = ±0.02 (0.50); .xxx = ±0.01 (0.25)
- Weight 0.5 lbs (230 g)

Output Power	Output Voltage	Output Current	Model Number ⁽¹⁾
30 W	5.0VDC	6.00 A	ECS45US05
45 W	12.0VDC	3.75 A	ECS45US12
45 W	15.0VDC	3.00 A	ECS45US15
45 W	24.0VDC	1.90 A	ECS45US24
45 W	48.0VDC	0.95 A	ECS45US48

Notes

1. For covered versions, add suffix '-C' to model number or order part number ECS25-60 COVER KIT for standalone cover. Not suitable for use in class II installations, derate output power by 20% with cover.

Mechanical Details

5 V version



Input Connector J1 Molex PN 09-65-2038	
Pin 1	Line
Pin 2	Neutral
0.25" Faston	Earth

Output Connector J2 Molex PN 09-65-2048	
Pin 1	+V1
Pin 2	+V1
Pin 3	RTN
Pin 4	RTN

J1 mates with Molex Housing PN 09-50-1031,
J2 mates with Molex Housing
PN 09-50-1041 and both with Molex Series
5194 Crimp Terminals
Faston ground tab requires insulated receptacle

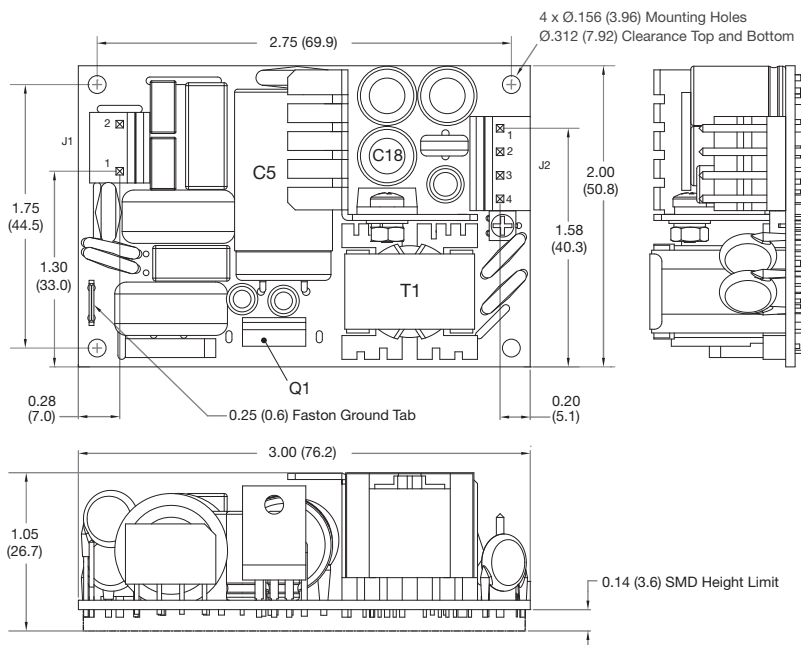

12-48 V version



Input Connector J1 Molex PN 09-65-2038	
Pin 1	Line
Pin 2	Neutral
0.25" Faston	Earth

Output Connector J2 Molex PN 09-65-2048	
Pin 1	+V1
Pin 2	+V1
Pin 3	RTN
Pin 4	RTN

J1 mates with Molex Housing PN
09-50-1031,
J2 mates with Molex Housing PN 09-50-1041 and
both with Molex Series 5194 Crimp Terminals
Faston ground tab requires insulated receptacle

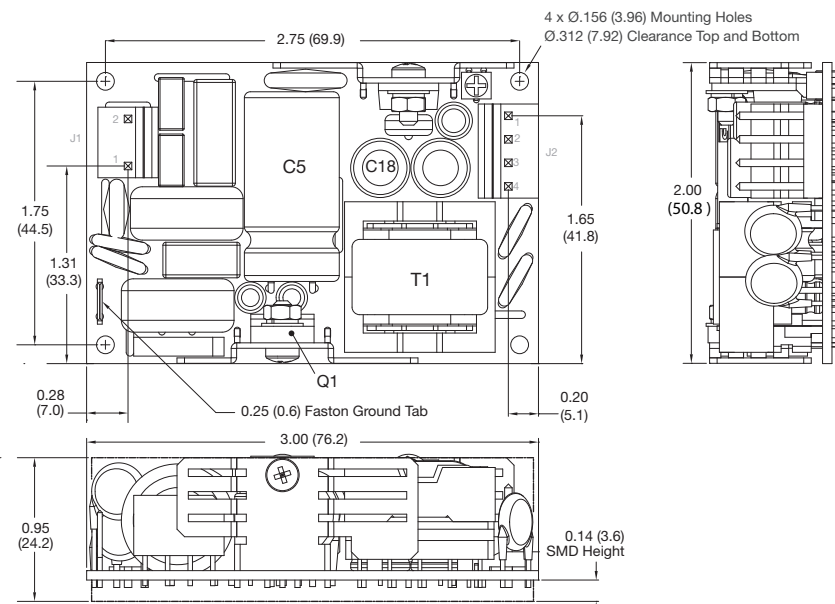

Notes

1. All dimensions in inches (mm).
Tolerance .xx = ±0.02 (0.50); .xxx = ±0.01 (0.25)

2. Weight 0.22 lbs (100 g)

Output Power	Output Voltage	Output Current	Model Number ⁽¹⁾
40 W	5.0 VDC	8.00 A	ECS60US05
60 W	12.0 VDC	5.00 A	ECS60US12
60 W	15.0 VDC	4.00 A	ECS60US15
60 W	24.0 VDC	2.50 A	ECS60US24
60 W	48.0 VDC	1.25 A	ECS60US48

Notes

1. For covered versions, add suffix '-C' to model number or order part number ECS25-60 COVER KIT for standalone cover. Not suitable for use in class II installations, derate output power by 20% with cover.

Mechanical Details

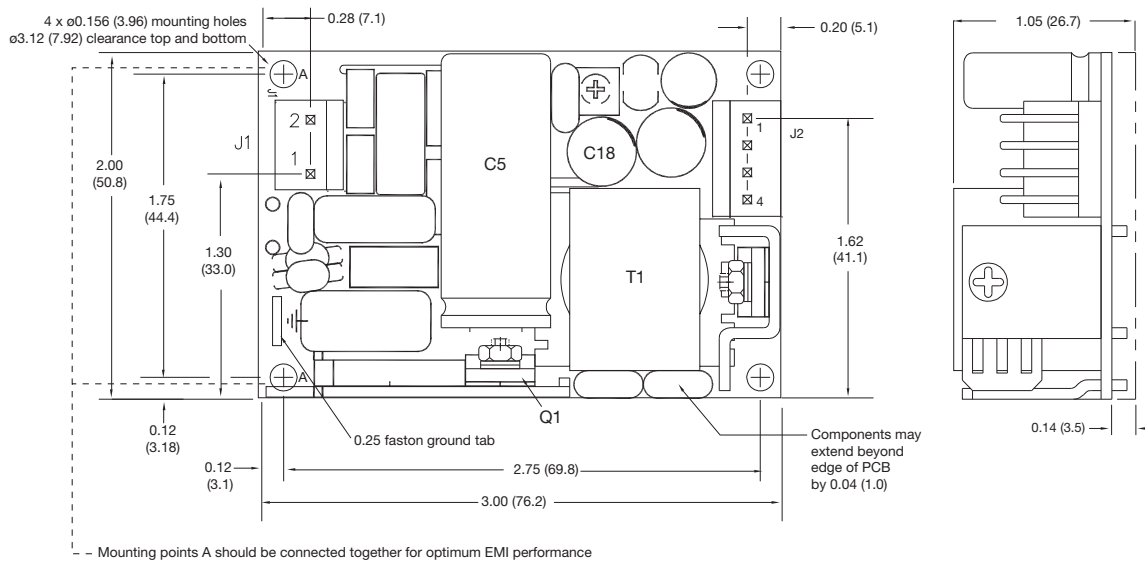

Input Connector J1 Molex PN 09-65-2038	
Pin 1	Line
Pin 2	Neutral
0.25" Faston	Earth

J1 mates with Molex Housing PN 09-50-1031
 Faston ground tab requires insulated receptacle

Output Connector J2 Molex PN 09-65-2048	
Pin 1	+V1
Pin 2	+V1
Pin 3	RTN
Pin 4	RTN

J2 mates with Molex Housing PN 09-50-1041
 and both with Molex Series 5194 Crimp Terminals
 Faston ground tab requires insulated receptacle

Notes

- 1. All dimensions in inches (mm).
 Tolerance .xx = \pm 0.02 (0.50); .xxx = \pm 0.01 (0.25)
- 2. Weight: 0.22 lbs (100 g)

Thermal Considerations (All ECS25-60 Models)

In order to ensure safe operation of the PSU in the most adverse conditions permitted in the end-use equipment, the temperature of the components listed in the table must not be exceeded. See mechanical drawings for component locations. Temperature should be monitored using K type thermocouples placed on the hottest part of the component (out of any direct air flow).

Temperature Measurements (Ambient \leq 50 °C)	
Component	Max Temperature °C
T1	120 °C
Q1	110 °C
C5	105 °C
C18	105 °C







Looking for pricing, stock, or lifecycle information?

Click below to explore more details on WIN SOURCE:

 [View ECS60US15 on WIN SOURCE](#)

 [XP Power Information](#)

Optimize Your Supply Chain with WIN SOURCE Solutions

-  Global Sourcing Solution
-  Obsolete Management
-  Cost Control Management
-  Shortage Management
-  Alternative Solution
-  Excess Inventory Management