

Chip Bead Array

Type: **EXC28B**



■ Features

- Space saving
- SSOP package (0.5 mm pitch) compatibility
- Small size and lightweight
- RoHS compliant

Type: EXC28BB

- Suitable for high speed signals (over 50 MHz)
- Excellent cross talk characteristics (100 MHz:<-25 dB)

Type: EXC28BA

- Reduces waveform ringing noise
- Excellent cross talk characteristics (100 MHz:<-30 dB)

■ Recommended Applications

- Small digital equipment such as PCs, printers, HDD, DVD-ROMs, CD-ROMs, LCDs.
- Digital audio and video equipment such as DSC, DVC, CD Players, DVD Players, MD Players.
- Electronic musical instruments, and other digital equipment.

■ Explanation of Part Numbers

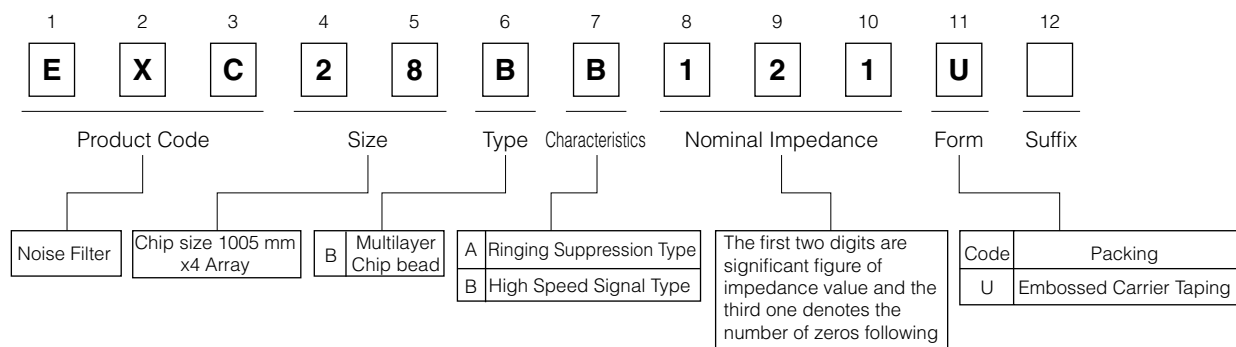

■ Construction

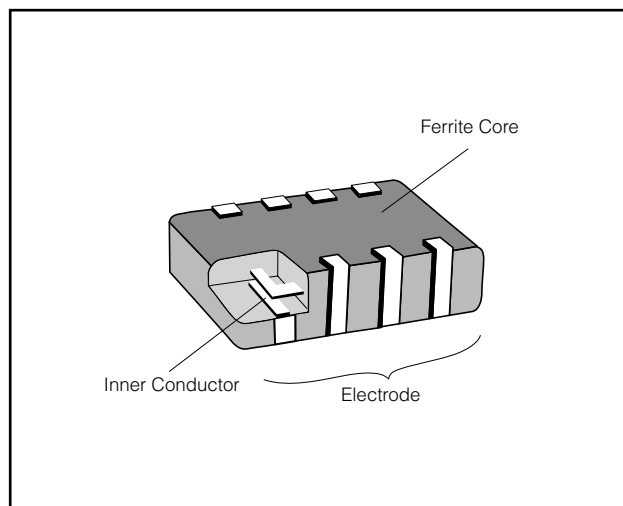

■ Dimensions in mm (not to scale)

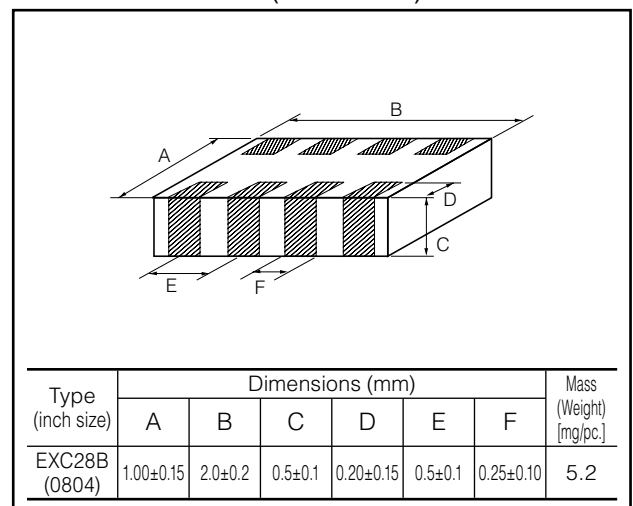

■ Ratings

Type	Part Number	Impedance		Rated Current (mA DC)	DC Resistance (Ω) max.
		(Ω) at 100MHz	tol.(%)		
BA	EXC28BA121U	120	±25	100	0.5
	EXC28BA221U	220			0.7
BB	EXC28BB121U	120			0.5
	EXC28BB221U	220			0.7

● Category Temperature Range -40 °C to +85 °C

■ Impedance Characteristics (Reference Data) Measured by HP4291A

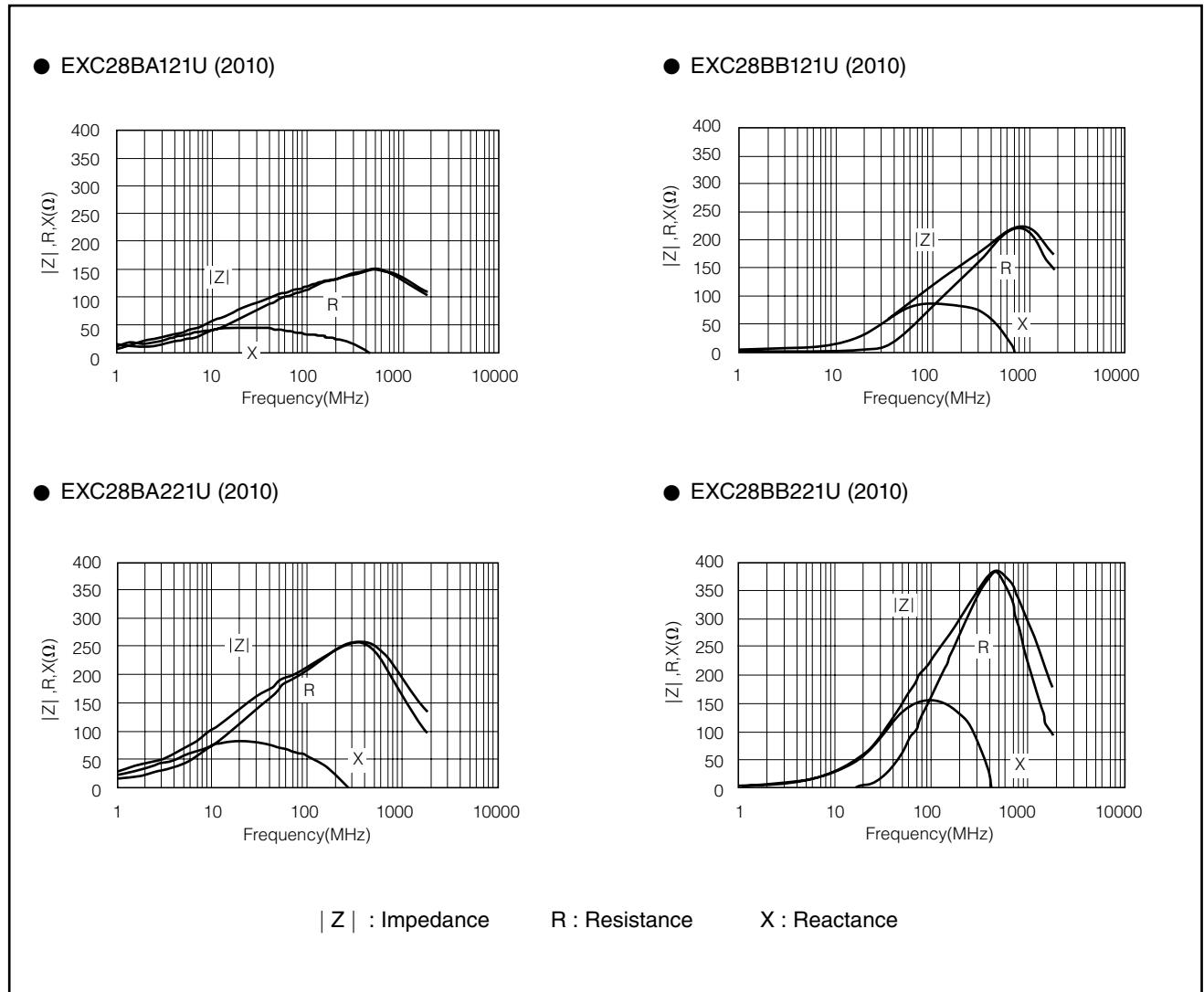

■ Circuit Configuration(No Polarity)

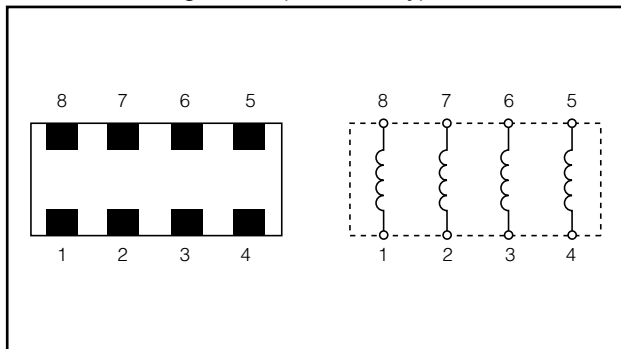

■ Packaging Methods (Taping)

● Standard Quantity

Part Number	Kind of Taping	Pitch (P ₁)	Quantity
EXC28B□□□□U	Embossed Carrier Taping	4 mm	5000 pcs./reel

● Embossed Carrier Taping

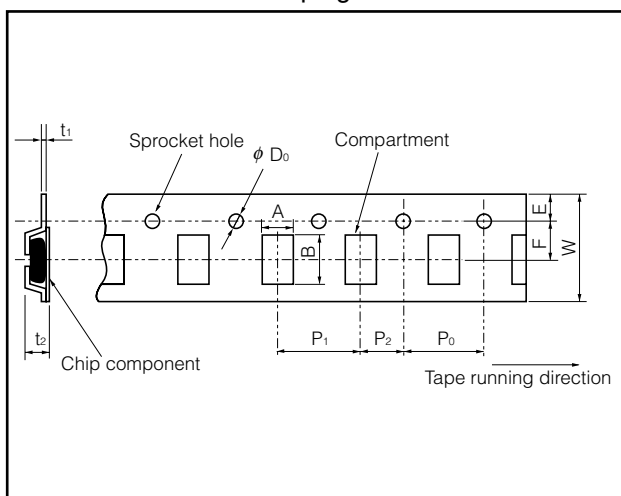

● Taping Reel

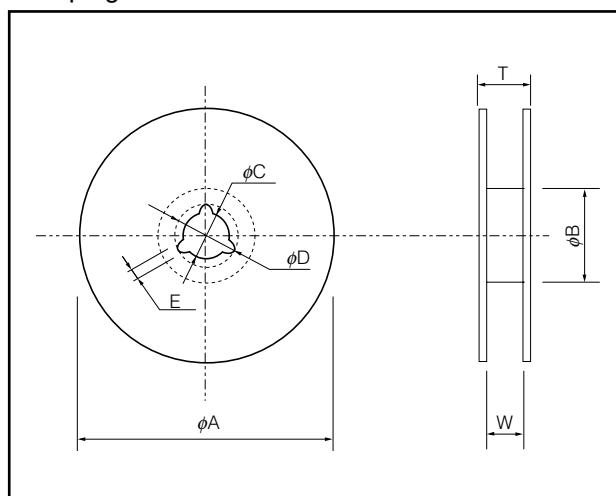

Embossed Carrier Dimensions (mm)

Part Number	A	B	W	F	E	P ₁	P ₂	P ₀	φD ₀	t ₁	t ₂
EXC28B□□□□U	1.20±0.15	2.25±0.15	8.0±0.2	3.5±0.1	1.75±0.10	4.0±0.1	2.0±0.1	4.0±0.1	1.5±0.1	0.25±0.05	0.90±0.15

Standard Reel Dimensions (mm)

Part Number	φA	φB	φC	φD	E	W	T
EXC28B□□□□U	180 ⁰ _{-3.0}	60.0±1.0	13.0±0.5	21.0±0.8	2.0±0.5	9.0±0.3	11.4±1.5

Recommended Land Pattern Design

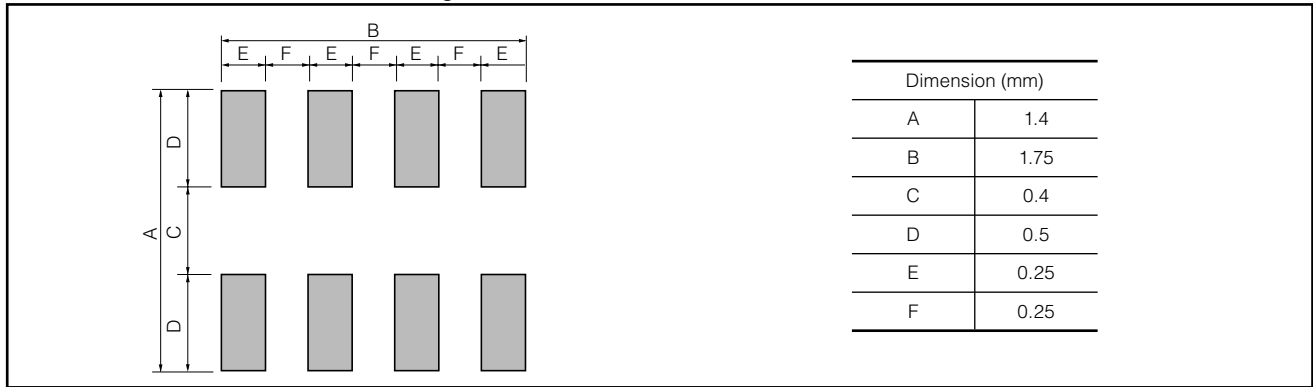

Recommended Soldering Conditions

Recommendations and precautions are described below.

- Recommended soldering conditions for reflow
 - Reflow soldering shall be performed a maximum of two times.
 - Please contact us for additional information when used in conditions other than those specified.
 - Please measure the temperature of the terminals and study every kind of solder and printed circuit board for solderability before actual use.

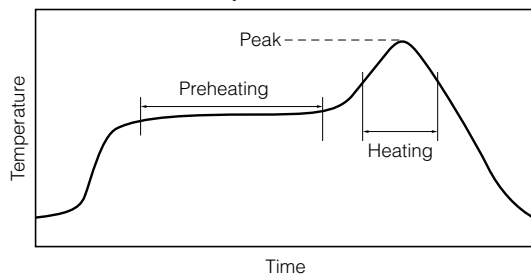

For soldering (Example : Sn-37Pb)

	Temperature	Time
Preheating	140 °C to 160 °C	60 s to 120 s
Main heating	Above 200 °C	30 s to 40 s
Peak	235 ± 10 °C	max. 10 s

For lead-free soldering (Example : Sn/3Ag/0.5Cu)

	Temperature	Time
Preheating	150 °C to 170 °C	60 s to 120 s
Main heating	Above 230 °C	30 s to 40 s
Peak	max. 260 °C	max. 10 s

- Flow soldering
 - We do not recommend flow soldering , because flow soldering may cause bridges between the electrodes.

<Repair with hand soldering>

- Preheat with a blast of hot air or similar method. Use a soldering iron with a tip temperature of 350 °C or less. Solder each electrode for 3 seconds or less.
- Never touch this product with the tip of a soldering iron.



⚠ Safety Precautions

The following are precautions for individual products. Please also refer to the common precautions for Noise Suppression Device shown on this catalog.

1. Use rosin-based flux or halogen-free flux.
2. For cleaning, use an alcohol-based cleaning agent. Before using any other type, consult with our sales person in advance.
3. Do not apply shock to Chip Bead Array (hereafter called the bead arrays) or pinch them with a hard tool (e.g. pliers and tweezers). Otherwise, their bodies may be chipped, affecting their performance. Excessive mechanical stress may damage the bead arrays. Handle with care.
4. Store the bead arrays in a location with a temperature ranging from -5 °C to +40 °C and a relative humidity of 40 % to 60 %, where there are no rapid changes in temperature or humidity.
5. Use the bead arrays within half a year after the date of the outgoing inspection indicated on the packages.

Looking for pricing, stock, or lifecycle information?

Click below to explore more details on WIN SOURCE:

-  [View EXC-28BA221U on WIN SOURCE](#)
-  [Panasonic Information](#)

Optimize Your Supply Chain with WIN SOURCE Solutions

-  Global Sourcing Solution
-  Obsolete Management
-  Cost Control Management
-  Shortage Management
-  Alternative Solution
-  Excess Inventory Management