



THE DATASHEET OF OPA2388ID



OPAx388 Precision, Zero-Drift, Zero-Crossover, True Rail-to-Rail, Input/Output Operational Amplifiers

1 Features

- Ultra-low offset voltage: $\pm 0.25 \mu\text{V}$
- Zero drift: $\pm 0.005 \mu\text{V}/^\circ\text{C}$
- Zero crossover: 140-dB CMRR true RRIO
- Low noise: $7.0 \text{ nV}/\sqrt{\text{Hz}}$ at 1 kHz
- No 1/f noise: $140 \text{ nV}_{\text{PP}}$ (0.1 Hz to 10 Hz)
- Fast settling: $2 \mu\text{s}$ (1 V to 0.01%)
- Gain bandwidth: 10 MHz
- Single supply: 2.5 V to 5.5 V
- Dual supply: $\pm 1.25 \text{ V}$ to $\pm 2.75 \text{ V}$
- True rail-to-rail input and output
- EMI/RFI filtered inputs
- Industry-standard packages:
 - Single in SOIC-8, SOT-23-5, and VSSOP-8
 - Dual in SOIC-8 and VSSOP-8
 - Quad in SOIC-14 and TSSOP-14

2 Applications

- [Merchant network and server PSU](#)
- [Notebook PC power adapter design](#)
- [Weigh scale](#)
- [Lab and field instrumentation](#)
- [Battery test](#)
- [Electronic thermometer](#)
- [Temperature transmitter](#)

3 Description

The OPAx388 (OPA388, OPA2388, and OPA4388) series of precision operational amplifiers are ultra-low noise, fast-settling, zero-drift, zero-crossover devices that provide rail-to-rail input and output operation. These features and excellent ac performance, combined with only $0.25 \mu\text{V}$ of offset and $0.005 \mu\text{V}/^\circ\text{C}$ of drift over temperature, makes the OPAx388 a great choice for driving high-precision, analog-to-digital converters (ADCs) or buffering the output of high-resolution, digital-to-analog converters (DACs). This design results in excellent performance when driving analog-to-digital converters (ADCs) without degradation of linearity. The OPA388 (single version) is available in the VSSOP-8, SOT23-5, and SOIC-8 packages. The OPA2388 (dual version) is offered in the VSSOP-8 and SO-8 packages. The OPA4388 (quad version) is offered in the TSSOP-14 and SO-14 packages. All versions are specified over the industrial temperature range of -40°C to $+125^\circ\text{C}$.

Device Information

PART NUMBER	PACKAGE ⁽¹⁾	BODY SIZE (NOM)
OPA388	SOIC (8)	4.90 mm × 3.90 mm
	SOT-23 (5)	2.90 mm × 1.60 mm
	VSSOP (8)	3.00 mm × 3.00 mm
OPA2388	SOIC (8)	4.90 mm × 3.90 mm
	VSSOP (8)	3.00 mm × 3.00 mm
OPA4388	SOIC (14)	8.65 mm × 3.90 mm
	TSSOP (14)	5.00 mm × 4.40 mm

- (1) For all available packages, see the package option addendum at the end of the data sheet.

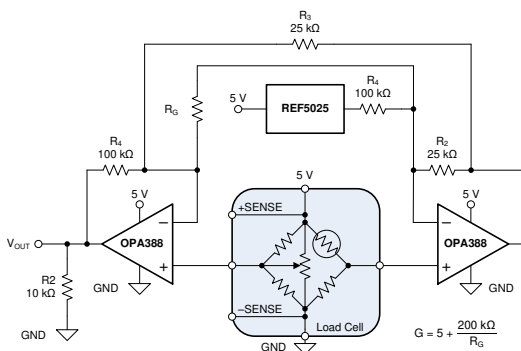

The OPA388 in a High-CMRR, Instrumentation Amplifier Application

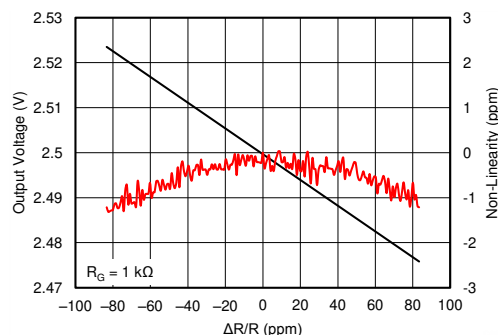

The OPA388 Allows Precision, Low-Error Measurements



Table of Contents

1 Features	1	7.4 Device Functional Modes.....	20
2 Applications	1	8 Application and Implementation	21
3 Description	1	8.1 Application Information.....	21
4 Revision History	2	8.2 Typical Applications.....	21
5 Pin Configuration and Functions	4	9 Power Supply Recommendations	25
6 Specifications	6	10 Layout	26
6.1 Absolute Maximum Ratings.....	6	10.1 Layout Guidelines.....	26
6.2 ESD Ratings.....	6	10.2 Layout Example.....	26
6.3 Recommended Operating Conditions.....	6	11 Device and Documentation Support	27
6.4 Thermal Information: OPA388.....	6	11.1 Device Support.....	27
6.5 Thermal Information: OPA2388.....	7	11.2 Documentation Support.....	27
6.6 Thermal Information: OPA4388.....	7	11.3 Related Links.....	27
6.7 Electrical Characteristics: VS = ±1.25 V to ±2.75 V (VS = 2.5 to 5.5 V).....	7	11.4 Receiving Notification of Documentation Updates..	27
6.8 Typical Characteristics.....	10	11.5 Support Resources.....	27
7 Detailed Description	18	11.6 Trademarks.....	28
7.1 Overview.....	18	11.7 Electrostatic Discharge Caution.....	28
7.2 Functional Block Diagram.....	18	11.8 Glossary.....	28
7.3 Feature Description.....	19	12 Mechanical, Packaging, and Orderable Information	28

4 Revision History

NOTE: Page numbers for previous revisions may differ from page numbers in the current version.

Changes from Revision C (May 2019) to Revision D (July 2020)	Page
• Changed OPA2388 SOIC-8 (D) package from advanced information (preview) to production data (active)	1
• Changed typical application schematic to show correct locations for reference designators.....	1
• Changed Figure 8-5 to show correct locations for reference designators	25

Changes from Revision B (January 2019) to Revision C (May 2019)	Page
• Changed OPA4388 from advanced information (preview) to production data (active).....	1
• Added VOS specifications for OPA4388.....	7
• Added dVOS/dT specifications for OPA4388.....	7
• Added PSRR specifications for OPA4388.....	7
• Added IB specifications for OPA4388.....	7
• Added IOS specifications for OPA4388.....	7
• Added CMRR specifications for OPA4388.....	7
• Added AOL specifications for OPA4388.....	7

Changes from Revision A (July 2018) to Revision B (January 2019)	Page
• Changed OPA388 DBV (SOT-23) package from preview to production data	1
• Deleted redundant temperature specification in EC table.....	7
• Added Figure 6, <i>Offset Voltage vs Supply Voltage: OPA4388</i>	10
• Added Figure 7, <i>Offset Voltage Long Term Drift</i>	10
• Changed Figure 50, <i>OPA388 Layout Example</i> ; updated for accuracy.....	26

Changes from Revision * (December 2016) to Revision A (July 2018)	Page
• Changed device status from Production Data to Production Data/Mixed Status.....	1
• Added top navigator link for TI reference design.....	1
• Added preview notes to 5-pin SOT-23 (OPA388), 8-pin SOIC (OPA2388), 14-pin SOIC, and 14-pin TSSOP (OPA4388) packages in <i>Device Information</i> table.....	1
• Added package preview notes to <i>Pin Configuration and Functions</i> section.....	4
• AOL test condition changed to 0.15 V from 0.1 V.....	7
• AOL test condition changed to 0.15 V from 0.1 V.....	7
• AOL test condition changed to 0.25 V from 0.2 V.....	7
• AOL test condition changed to 0.3 V from 0.25 V.....	7

5 Pin Configuration and Functions

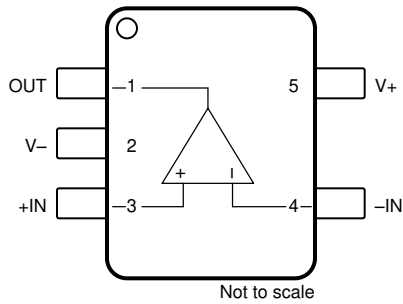

Figure 5-1. OPA388 DBV Package, 5-Pin SOT-23, Top View

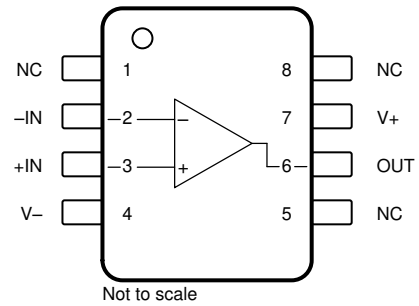

Figure 5-2. OPA388 D and DGK Packages, 8-Pin SOIC and VSSOP, Top View

Pin Functions: OPA388

NAME	PIN		I/O	DESCRIPTION
	OPA388			
	D (SOIC), DGK (VSSOP)	DBV (SOT-23)		
-IN	2	4	I	Inverting input
+IN	3	3	I	Noninverting input
NC	1, 5, 8	—	—	No internal connection (can be left floating)
OUT	6	1	O	Output
V-	4	2	—	Negative (lowest) power supply
V+	7	5	—	Positive (highest) power supply

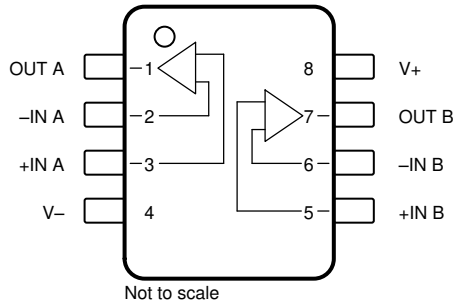

Figure 5-3. OPA2388 8-Pin SOIC (D) Package and 8-Pin VSSOP (DGK) Package, Top View

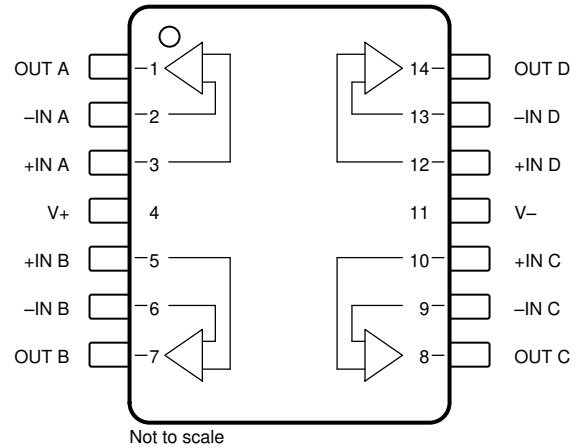

Figure 5-4. OPA4388 14-Pin SOIC (D) and TSSOP-14 (PW) Packages, Top View

Pin Functions: OPA2388 and OPA4388

NAME	PIN		I/O	DESCRIPTION
	OPA2388 D (SOIC), DGK (VSSOP)	OPA4388 D (SOIC), PW (TSSOP)		
-IN A	2	2	I	Inverting input, channel A
-IN B	6	6	I	Inverting input, channel B
-IN C	—	9	I	Inverting input, channel C
-IN D	—	13	I	Inverting input, channel D
+IN A	3	3	I	Noninverting input, channel A
+IN B	5	5	I	Noninverting input, channel B
+IN C	—	10	I	Noninverting input, channel C
+IN D	—	12	I	Noninverting input, channel D
OUT A	1	1	O	Output, channel A
OUT B	7	7	O	Output, channel B
OUT C	—	8	O	Output, channel C
OUT D	—	14	O	Output, channel D
V-	4	11	—	Negative (lowest) power supply
V+	8	4	—	Positive (highest) power supply

6 Specifications

6.1 Absolute Maximum Ratings

over operating free-air temperature range (unless otherwise noted)⁽¹⁾

			MIN	MAX	UNIT
Supply voltage	$V_S = (V+) - (V-)$	Single-supply		6	V
		Dual-supply		±3	
Signal input pins	Voltage	Common-mode	(V-) – 0.5	(V+) + 0.5	V
		Differential		(V+) – (V-) + 0.2	
	Current			±10	mA
Output short circuit ⁽²⁾			Continuous	Continuous	
Temperature	Operating, T_A		–55	150	°C
	Junction, T_J			150	
	Storage, T_{stg}		–65	150	

- (1) Stresses beyond those listed under *Absolute Maximum Ratings* may cause permanent damage to the device. These are stress ratings only, which do not imply functional operation of the device at these or any other conditions beyond those indicated under *Recommended Operating Conditions*. Exposure to absolute-maximum-rated conditions for extended periods may affect device reliability.
- (2) Short-circuit to ground, one amplifier per package.

6.2 ESD Ratings

			VALUE	UNIT
$V_{(ESD)}$	Electrostatic discharge	Human-body model (HBM), per ANSI/ESDA/JEDEC JS-001 ⁽¹⁾	±4000	V
		Charged-device model (CDM), per JEDEC specification JESD22-C101 ⁽²⁾	±1000	

- (1) JEDEC document JEP155 states that 500-V HBM allows safe manufacturing with a standard ESD control process.
- (2) JEDEC document JEP157 states that 250-V CDM allows safe manufacturing with a standard ESD control process.

6.3 Recommended Operating Conditions

over operating free-air temperature range (unless otherwise noted)

		MIN	NOM	MAX	UNIT
Supply voltage, $V_S = (V+) - (V-)$	Single-supply	2.5		5.5	V
	Dual-supply	±1.25		±2.75	
Specified temperature		–40		125	°C

6.4 Thermal Information: OPA388

THERMAL METRIC ⁽¹⁾		OPA388			UNIT
		D (SOIC)	DBV (SOT-23)	DGK (VSSOP)	
		8 PINS	5 PINS	5 PINS	
$R_{\theta JA}$	Junction-to-ambient thermal resistance	116	145.7	177	°C/W
$R_{\theta JC(top)}$	Junction-to-case (top) thermal resistance	60	94.8	69	°C/W
$R_{\theta JB}$	Junction-to-board thermal resistance	56	43.4	100	°C/W
Ψ_{JT}	Junction-to-top characterization parameter	12.8	24.7	9.9	°C/W
Ψ_{JB}	Junction-to-board characterization parameter	55.9	43.1	98.3	°C/W
$R_{\theta JC(bot)}$	Junction-to-case (bottom) thermal resistance	N/A	N/A	n/a	°C/W

- (1) For more information about traditional and new thermal metrics, see the [Semiconductor and IC Package Thermal Metrics application report](#).

6.5 Thermal Information: OPA2388

THERMAL METRIC ⁽¹⁾		OPA2388		UNIT
		D (SOIC)	DGK (VSSOP)	
		8 PINS	8 PINS	
R _{θJA}	Junction-to-ambient thermal resistance	120.0	165	°C/W
R _{θJC(top)}	Junction-to-case (top) thermal resistance	52.3	53	°C/W
R _{θJB}	Junction-to-board thermal resistance	65.6	87	°C/W
Ψ _{JT}	Junction-to-top characterization parameter	9.6	4.9	°C/W
Ψ _{JB}	Junction-to-board characterization parameter	64.4	85	°C/W
R _{θJC(bot)}	Junction-to-case (bottom) thermal resistance	N/A	N/A	°C/W

(1) For more information about traditional and new thermal metrics, see the [Semiconductor and IC Package Thermal Metrics application report](#).

6.6 Thermal Information: OPA4388

THERMAL METRIC ⁽¹⁾		OPA4388		UNIT
		D (SOIC)	PW (TSSOP)	
		14 PINS	14 PINS	
R _{θJA}	Junction-to-ambient thermal resistance	86.4	109.6	°C/W
R _{θJC(top)}	Junction-to-case (top) thermal resistance	46.3	27.4	°C/W
R _{θJB}	Junction-to-board thermal resistance	41.0	56.1	°C/W
Ψ _{JT}	Junction-to-top characterization parameter	11.3	1.5	°C/W
Ψ _{JB}	Junction-to-board characterization parameter	40.7	54.9	°C/W
R _{θJC(bot)}	Junction-to-case (bottom) thermal resistance	N/A	N/A	°C/W

(1) For more information about traditional and new thermal metrics, see the [Semiconductor and IC Package Thermal Metrics application report](#).

6.7 Electrical Characteristics: VS = ±1.25 V to ±2.75 V (VS = 2.5 to 5.5 V)

at T_A = 25°C, V_{CM} = V_{OUT} = V_S / 2, and R_{LOAD} = 10 kΩ connected to V_S / 2 (unless otherwise noted)

PARAMETER		TEST CONDITIONS	MIN	TYP	MAX	UNIT	
OFFSET VOLTAGE							
V _{OS}	Input offset voltage	OPA388, OPA2388		±0.25	±5	μV	
		V _S = 5.5 V	OPA4388		±2.25		±8
		T _A = -40°C to +125°C	OPA388, OPA2388				±7.5
		T _A = -40°C to +125°C, V _S = 5.5 V	OPA4388				±10.5
dV _{OS} /dT	Input offset voltage drift	T _A = -40°C to +125°C	OPA388, OPA2388	±0.005	±0.05	μV/°C	
		T _A = -40°C to +125°C, V _S = 5.5 V	OPA4388	±0.005	±0.05		
PSRR	Power-supply rejection ratio	T _A = -40°C to +125°C	OPA388, OPA2388	±0.1	±1	μV/V	
			OPA4388	±1.25	±3.5		

6.7 Electrical Characteristics: VS = ±1.25 V to ±2.75 V (VS = 2.5 to 5.5 V) (continued)

at TA = 25°C, VCM = VOUT = VS / 2, and RLOAD = 10 kΩ connected to VS / 2 (unless otherwise noted)

PARAMETER		TEST CONDITIONS		MIN	TYP	MAX	UNIT
INPUT BIAS CURRENT							
IB	Input bias current	RIN = 100 kΩ, OPA388, OPA2388	TA = 0°C to +85°C		±30	±350	pA
			TA = -40°C to +125°C			±400	
						±700	
		RIN = 100 kΩ, OPA4388			±30	±500	
			TA = 0°C to +85°C			±600	
			TA = -40°C to +125°C			±800	
IOS	Input offset current	RIN = 100 kΩ, OPA388, OPA2388	TA = 0°C to +85°C			±700	
			TA = -40°C to +125°C			±800	
						±800	
		RIN = 100 kΩ, OPA4388				±1000	
			TA = 0°C to +85°C			±1100	
			TA = -40°C to +125°C			±1100	
NOISE							
EN	Input voltage noise	f = 0.1 Hz to 10 Hz			0.14		μVPP
eN	Input voltage noise density	f = 10 Hz			7		nV/√Hz
		f = 100 Hz			7		
		f = 1 kHz			7		
		f = 10 kHz			7		
IN	Input current noise density	f = 1 kHz			100		fA/√Hz
INPUT VOLTAGE							
VCM	Common-mode voltage range			(V-) - 0.1		(V+) + 0.1	V
CMRR	Common-mode rejection ratio	(V-) - 0.1 V < VCM < (V+) + 0.1 V	VS = ±1.25 V OPA388, OPA2388	124	138		dB
			VS = ±1.25 V OPA4388	102	110		
			VS = ±2.75 V	124	140		
		(V-) < VCM < (V+) + 0.1 V, TA = -40°C to +125°C	VS = ±1.25 V OPA388, OPA2388	114	134		
			VS = ±1.25 V OPA4388	102	107		
			VS = ±2.75 V	124	140		
(V-) - 0.05 V < VCM < (V+) + 0.1 V, TA = -40°C to +125°C	VS = ±1.25 V						
	VS = ±2.75 V						
INPUT IMPEDANCE							
Zid	Differential input impedance				100 2		MΩ pF
Zic	Common-mode input impedance				60 4.5		TΩ pF

6.7 Electrical Characteristics: $V_S = \pm 1.25\text{ V}$ to $\pm 2.75\text{ V}$ ($V_S = 2.5$ to 5.5 V) (continued)

at $T_A = 25^\circ\text{C}$, $V_{CM} = V_{OUT} = V_S / 2$, and $R_{LOAD} = 10\text{ k}\Omega$ connected to $V_S / 2$ (unless otherwise noted)

PARAMETER		TEST CONDITIONS		MIN	TYP	MAX	UNIT	
OPEN-LOOP GAIN								
A_{OL}	Open-loop voltage gain	$(V^-) + 0.15\text{ V} < V_O < (V^+) - 0.15\text{ V}$, $R_{LOAD} = 10\text{ k}\Omega$		126	148		dB	
		$(V^-) + 0.15\text{ V} < V_O < (V^+) - 0.15\text{ V}$, $R_{LOAD} = 10\text{ k}\Omega$, $T_A = -40^\circ\text{C}$ to $+125^\circ\text{C}$		OPA388, OPA2388	120	126		
		$(V^-) + 0.15\text{ V} < V_O < (V^+) - 0.15\text{ V}$, $R_{LOAD} = 10\text{ k}\Omega$, $V_S = 5.5\text{ V}$, $T_A = -40^\circ\text{C}$ to $+125^\circ\text{C}$		OPA4388	120	126		
		$(V^-) + 0.25\text{ V} < V_O < (V^+) - 0.25\text{ V}$, $R_{LOAD} = 2\text{ k}\Omega$			126	148		
		$(V^-) + 0.30\text{ V} < V_O < (V^+) - 0.30\text{ V}$, $R_{LOAD} = 2\text{ k}\Omega$		OPA388, OPA2388	120	148		
		$(V^-) + 0.30\text{ V} < V_O < (V^+) - 0.30\text{ V}$, $R_{LOAD} = 2\text{ k}\Omega$, $V_S = 5.5\text{ V}$, $T_A = -40^\circ\text{C}$ to $+125^\circ\text{C}$		OPA4388	120	126		
FREQUENCY RESPONSE								
GBW	Unity-gain bandwidth				10		MHz	
SR	Slew rate	$G = 1$, 4-V step			5		V/ μs	
THD+N	Total harmonic distortion + noise	$G = 1$, $f = 1\text{ kHz}$, $V_O = 1\text{ V}_{RMS}$			0.0005%			
t_S	Settling time	To 0.1%	$V_S = \pm 2.5\text{ V}$, $G = 1$, 1-V step		0.75		μs	
		To 0.01%	$V_S = \pm 2.5\text{ V}$, $G = 1$, 1-V step		2		μs	
t_{OR}	Overload recovery time	$V_{IN} \times G = V_S$			10		μs	
OUTPUT								
V_O	Voltage output swing from rail	Positive rail	No load		1	15	mV	
			$R_{LOAD} = 10\text{ k}\Omega$		5	20		
			$R_{LOAD} = 2\text{ k}\Omega$		20	50		
		Negative rail	No load		5	15		
			$R_{LOAD} = 10\text{ k}\Omega$		10	20		
			$R_{LOAD} = 2\text{ k}\Omega$		40	60		
$T_A = -40^\circ\text{C}$ to $+125^\circ\text{C}$, both rails, $R_{LOAD} = 10\text{ k}\Omega$			10	25				
I_{SC}	Short-circuit current	$V_S = 5.5\text{ V}$			± 60		mA	
		$V_S = 2.5\text{ V}$			± 30		mA	
C_{LOAD}	Capacitive load drive	See Figure 6-26						
Z_O	Open-loop output impedance	$f = 1\text{ MHz}$, $I_O = 0\text{ A}$, see Figure 6-25			100		Ω	
POWER SUPPLY								
I_Q	Quiescent current per amplifier	$V_S = \pm 1.25\text{ V}$ ($V_S = 2.5\text{ V}$)	$I_O = 0\text{ A}$		1.7	2.4	mA	
			$T_A = -40^\circ\text{C}$ to $+125^\circ\text{C}$, $I_O = 0\text{ A}$		1.7	2.4		
		$V_S = \pm 2.75\text{ V}$ ($V_S = 5.5\text{ V}$)	$I_O = 0\text{ A}$		1.9	2.6		
			$T_A = -40^\circ\text{C}$ to $+125^\circ\text{C}$, $I_O = 0\text{ A}$		1.9	2.6		

6.8 Typical Characteristics

at $T_A = 25^\circ\text{C}$, $V_S = \pm 2.5\text{ V}$, $V_{CM} = V_S / 2$, $R_{LOAD} = 10\text{ k}\Omega$ connected to $V_S / 2$, and $C_L = 100\text{ pF}$ (unless otherwise noted)

Table 6-1. Table of Graphs

DESCRIPTION	FIGURE
Offset Voltage Production Distribution	Figure 6-1
Offset Voltage Drift Distribution From -40°C to $+125^\circ\text{C}$	Figure 6-2
Offset Voltage vs Temperature	Figure 6-3
Offset Voltage vs Common-Mode Voltage	Figure 6-4
Offset Voltage vs Power Supply: OPA388 and OPA2388	Figure 6-5
Offset Voltage vs Power Supply: OPA4388	Figure 6-6
Offset Voltage Long Term Drift	Figure 6-7
Open-Loop Gain and Phase vs Frequency	Figure 6-8
Closed-Loop Gain and Phase vs Frequency	Figure 6-9
Input Bias Current vs Common-Mode Voltage	Figure 6-10
Input Bias Current vs Temperature	Figure 6-11
Output Voltage Swing vs Output Current (Maximum Supply)	Figure 6-12
CMRR and PSRR vs Frequency	Figure 6-13
CMRR vs Temperature	Figure 6-14
PSRR vs Temperature	Figure 6-15
0.1-Hz to 10-Hz Noise	Figure 6-16
Input Voltage Noise Spectral Density vs Frequency	Figure 6-17
THD+N Ratio vs Frequency	Figure 6-18
THD+N vs Output Amplitude	Figure 6-19
Spectral Content	Figure 6-20 , Figure 6-21
Quiescent Current vs Supply Voltage	Figure 6-22
Quiescent Current vs Temperature	Figure 6-23
Open-Loop Gain vs Temperature	Figure 6-24
Open-Loop Output Impedance vs Frequency	Figure 6-25
Small-Signal Overshoot vs Capacitive Load (10-mV Step)	Figure 6-26
No Phase Reversal	Figure 6-27
Positive Overload Recovery	Figure 6-28
Negative Overload Recovery	Figure 6-29
Small-Signal Step Response (10-mV Step)	Figure 6-30 , Figure 6-31
Large-Signal Step Response (4-V Step)	Figure 6-32 , Figure 6-33
Settling Time	Figure 6-34 , Figure 6-35
Short-Circuit Current vs Temperature	Figure 6-36
Maximum Output Voltage vs Frequency	Figure 6-37
EMIRR vs Frequency	Figure 6-38

6.8 Typical Characteristics (continued)

at $T_A = 25^\circ\text{C}$, $V_S = \pm 2.5\text{ V}$, $V_{CM} = V_S / 2$, $R_{LOAD} = 10\text{ k}\Omega$ connected to $V_S / 2$, and $C_L = 100\text{ pF}$ (unless otherwise noted)

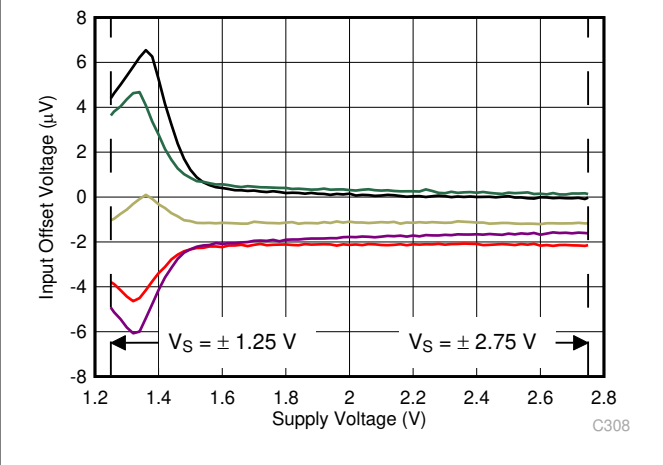
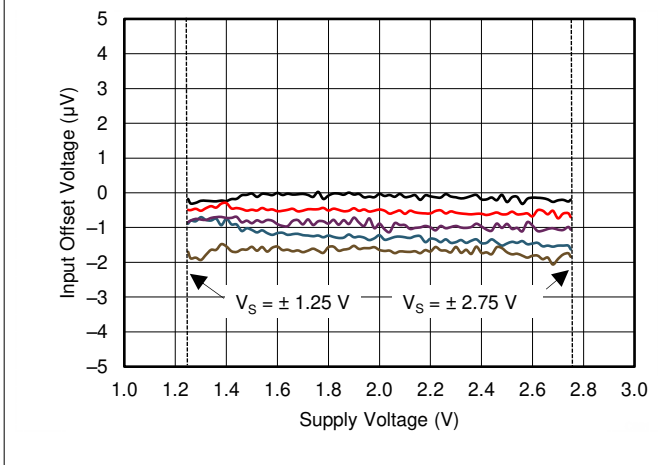
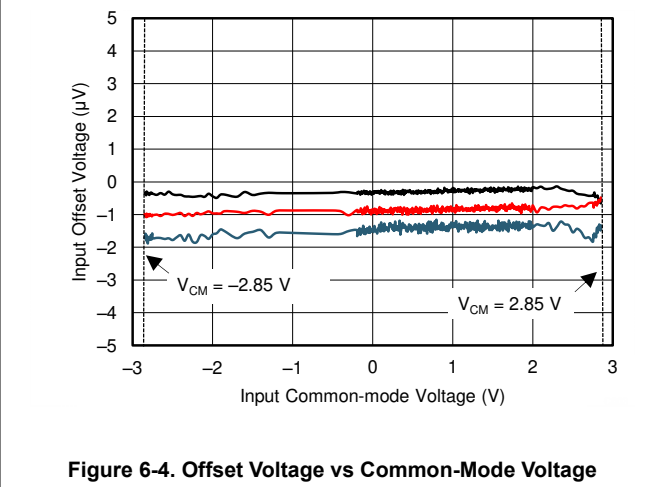
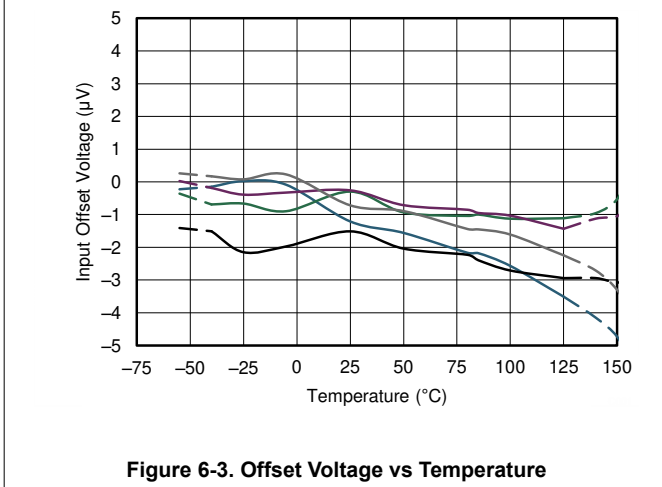
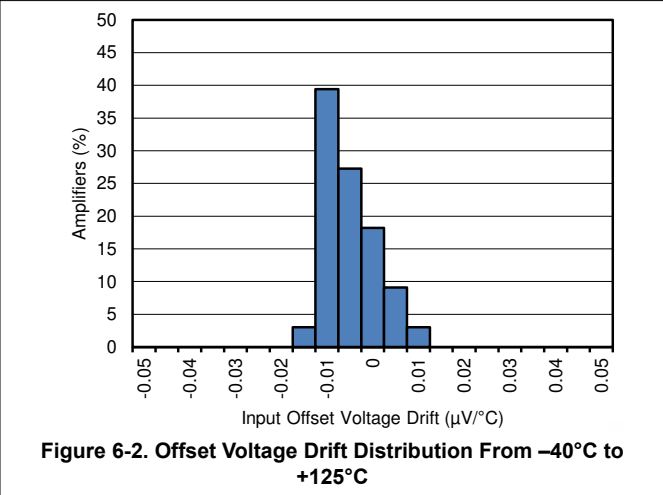
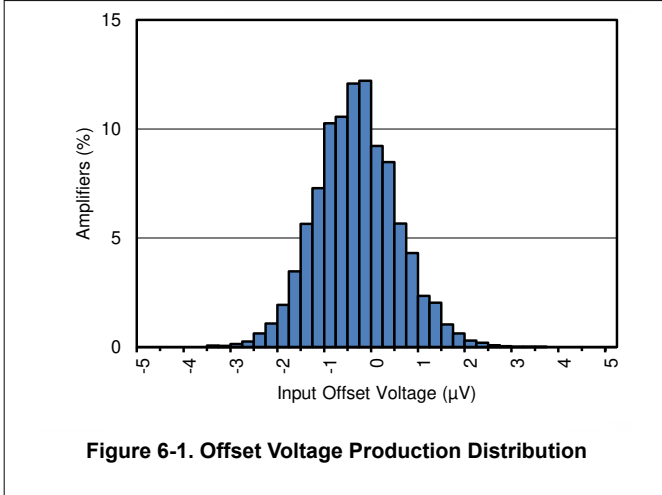

6.8 Typical Characteristics (continued)

at $T_A = 25^\circ\text{C}$, $V_S = \pm 2.5\text{ V}$, $V_{CM} = V_S / 2$, $R_{LOAD} = 10\text{ k}\Omega$ connected to $V_S / 2$, and $C_L = 100\text{ pF}$ (unless otherwise noted)

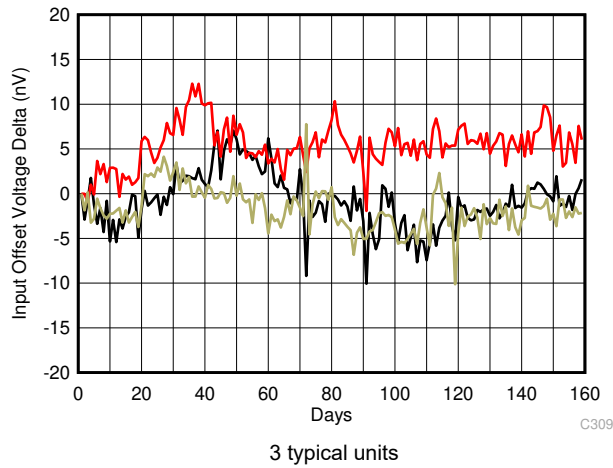

Figure 6-7. Offset Voltage Long Term Drift

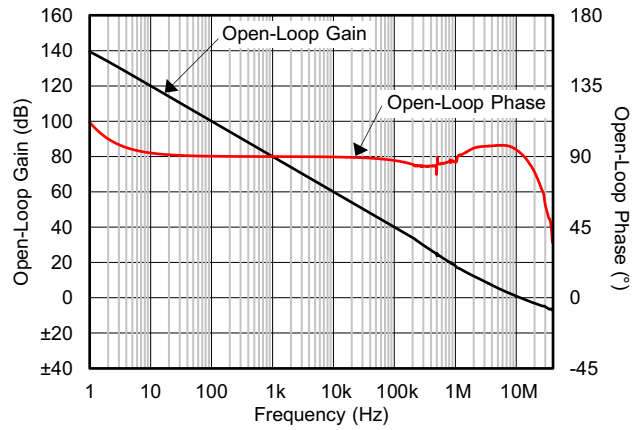

Figure 6-8. Open-Loop Gain and Phase vs Frequency

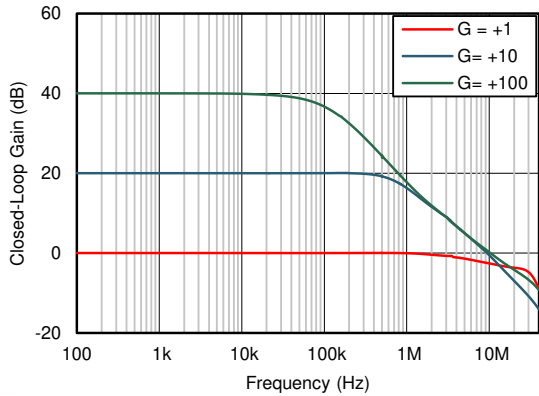

Figure 6-9. Closed-Loop Gain and Phase vs Frequency

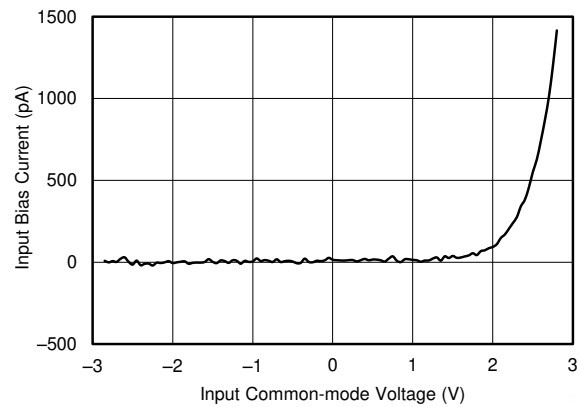

Figure 6-10. Input Bias Current vs Common-Mode Voltage

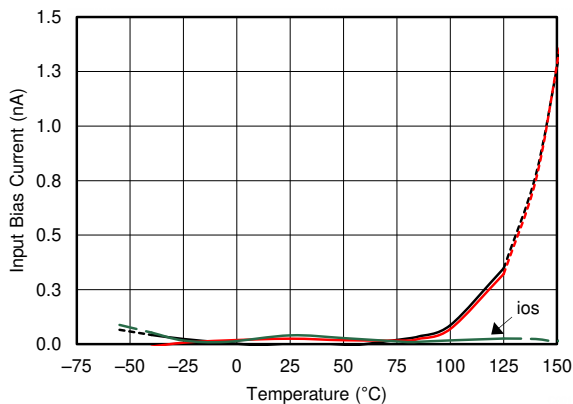

Figure 6-11. Input Bias Current vs Temperature

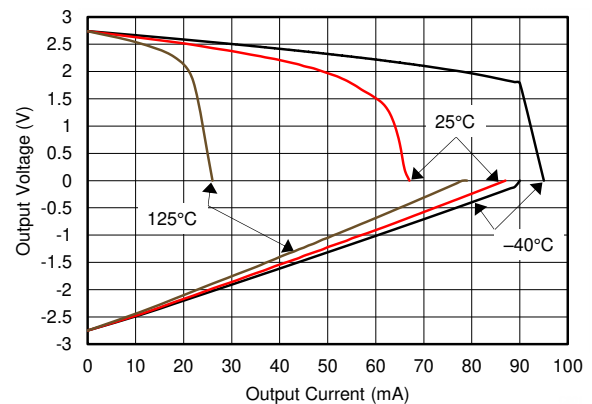
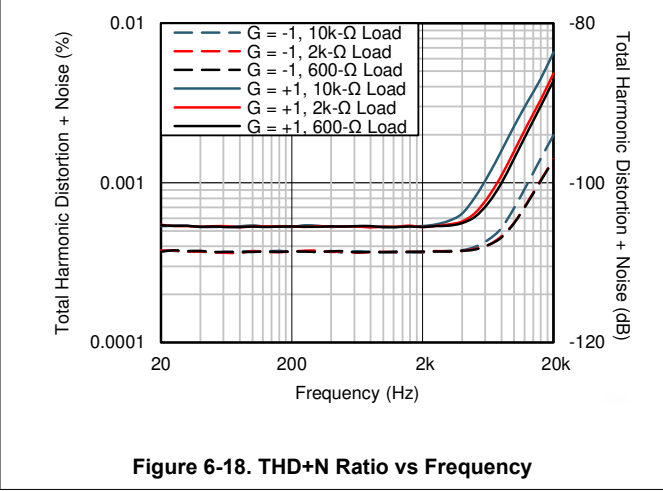
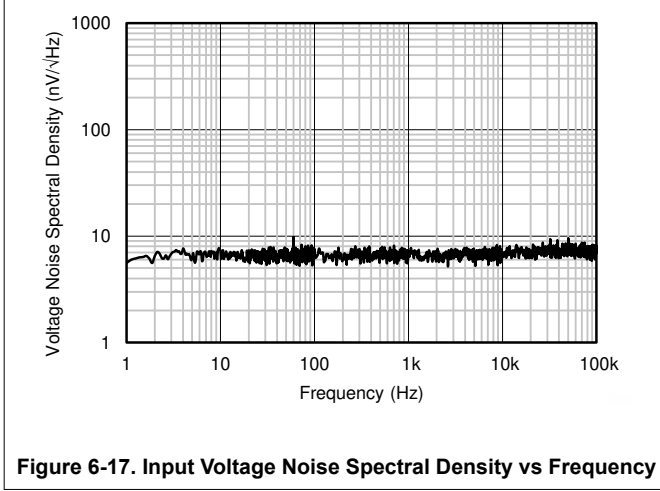
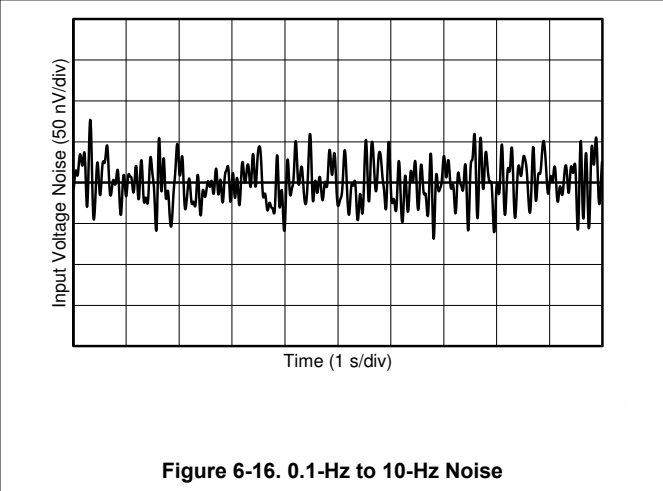
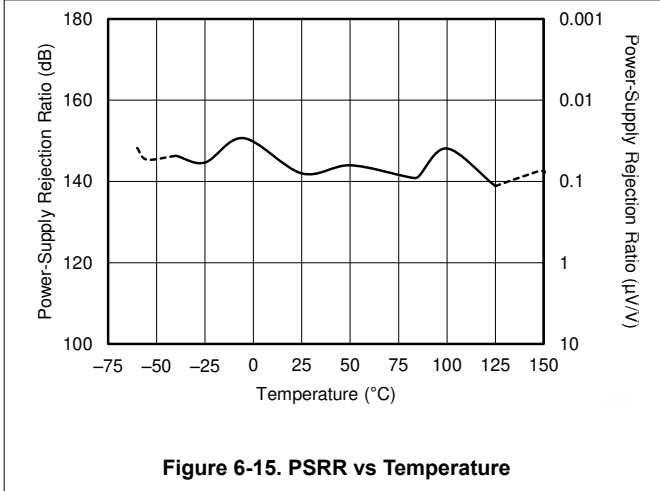
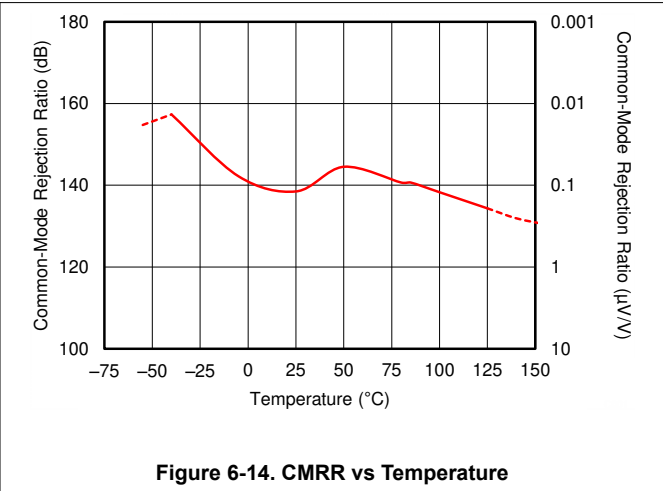
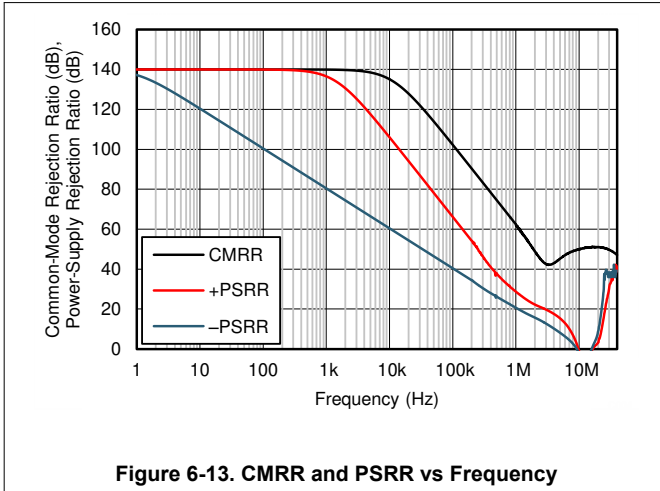

Figure 6-12. Output Voltage Swing vs Output Current (Maximum Supply)

6.8 Typical Characteristics (continued)

at $T_A = 25^\circ\text{C}$, $V_S = \pm 2.5\text{ V}$, $V_{CM} = V_S / 2$, $R_{LOAD} = 10\text{ k}\Omega$ connected to $V_S / 2$, and $C_L = 100\text{ pF}$ (unless otherwise noted)



6.8 Typical Characteristics (continued)

at $T_A = 25^\circ\text{C}$, $V_S = \pm 2.5\text{ V}$, $V_{CM} = V_S / 2$, $R_{LOAD} = 10\text{ k}\Omega$ connected to $V_S / 2$, and $C_L = 100\text{ pF}$ (unless otherwise noted)

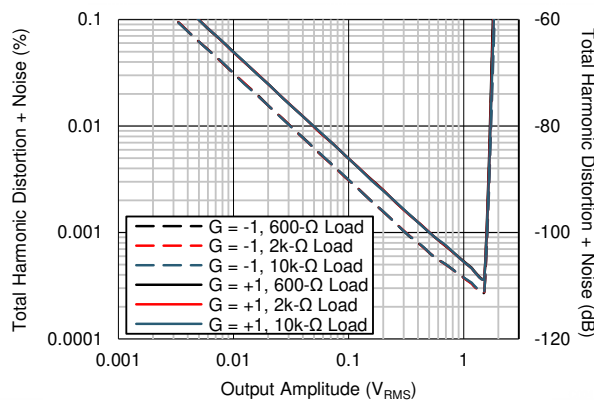
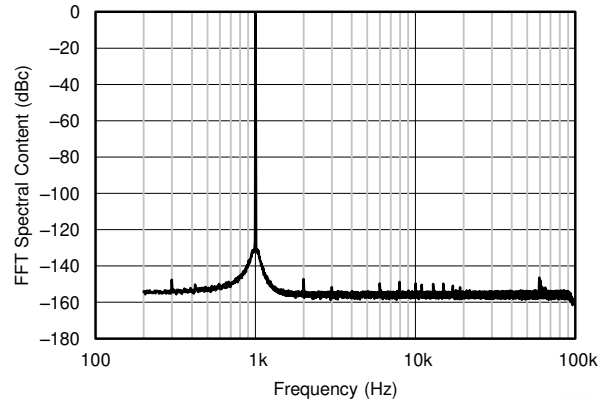
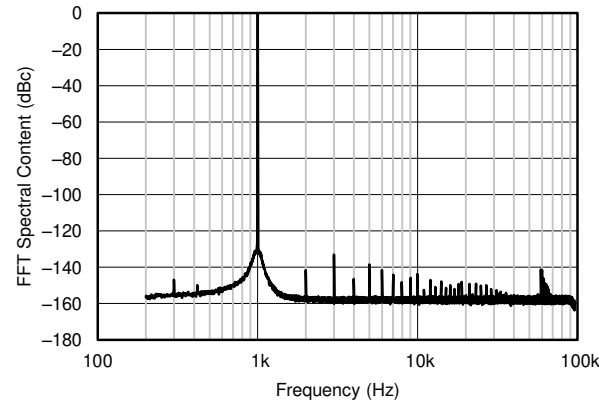

Figure 6-19. THD+N vs Output Amplitude



$G = +1$, $f = 1\text{ kHz}$, $V_O = 4.5\text{ V}_{PP}$, $R_L = 10\text{ k}\Omega$, $BW = 90\text{ kHz}$

Figure 6-20. Spectral Content (With 10-kΩ Load)



$G = +1$, $f = 1\text{ kHz}$, $V_O = 4.5\text{ V}_{PP}$, $R_L = 2\text{ k}\Omega$, $BW = 90\text{ kHz}$

Figure 6-21. Spectral Content (With 2-kΩ Load)

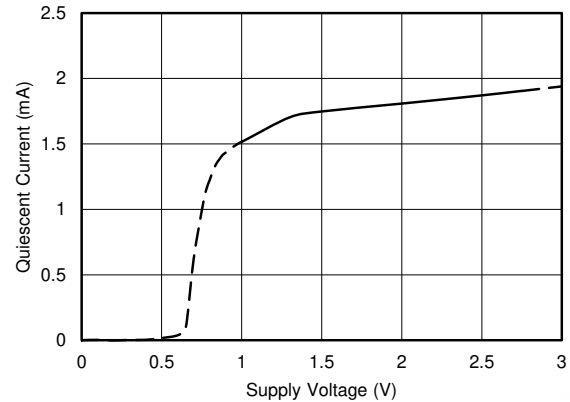

Figure 6-22. Quiescent Current vs Supply Voltage

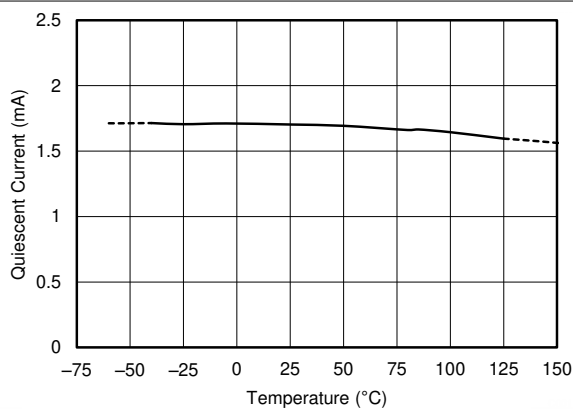

Figure 6-23. Quiescent Current vs Temperature

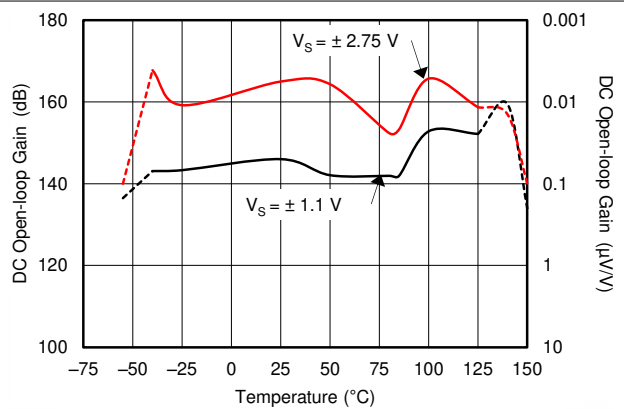

Figure 6-24. Open-Loop Gain vs Temperature

6.8 Typical Characteristics (continued)

at $T_A = 25^\circ\text{C}$, $V_S = \pm 2.5\text{ V}$, $V_{CM} = V_S / 2$, $R_{LOAD} = 10\text{ k}\Omega$ connected to $V_S / 2$, and $C_L = 100\text{ pF}$ (unless otherwise noted)

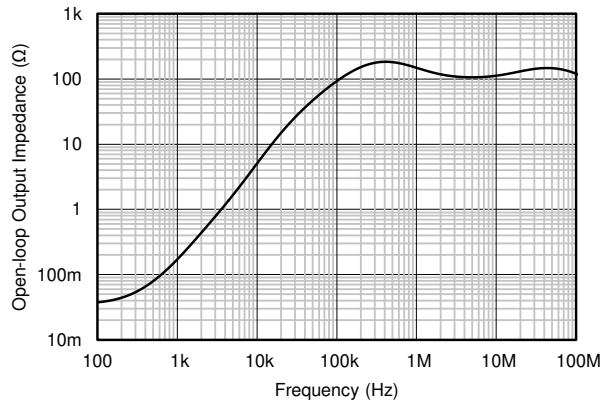

Figure 6-25. Open-Loop Output Impedance vs Frequency

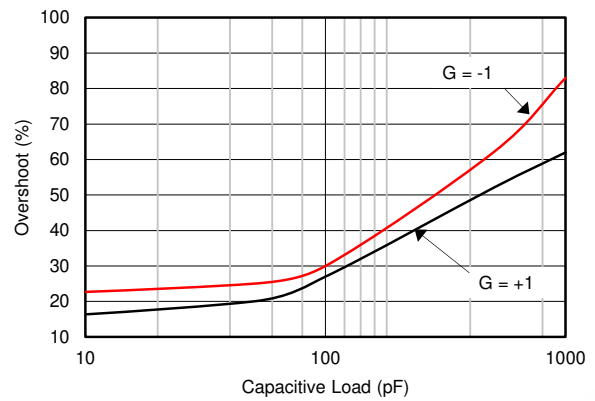

Figure 6-26. Small-Signal Overshoot vs Capacitive Load (10-mV Step)

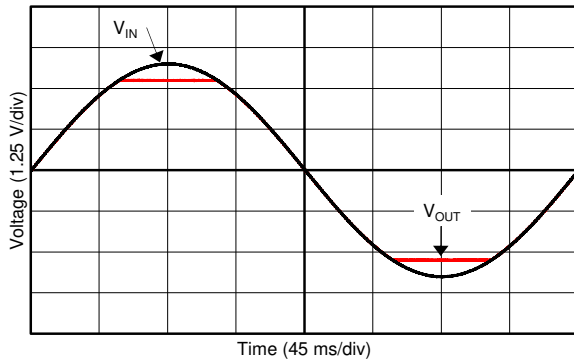

Figure 6-27. No Phase Reversal

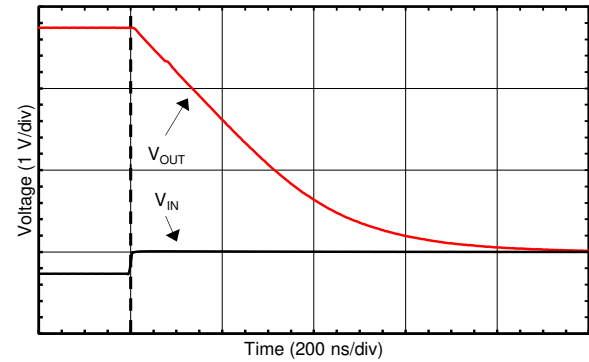

Figure 6-28. Positive Overload Recovery

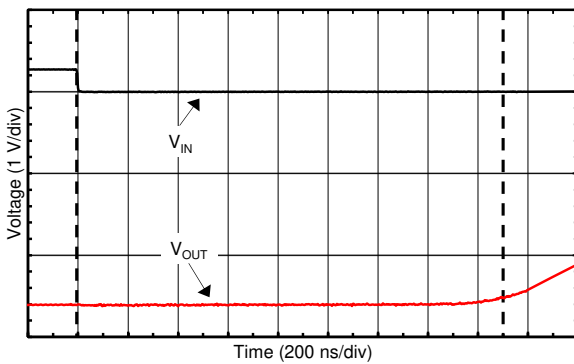
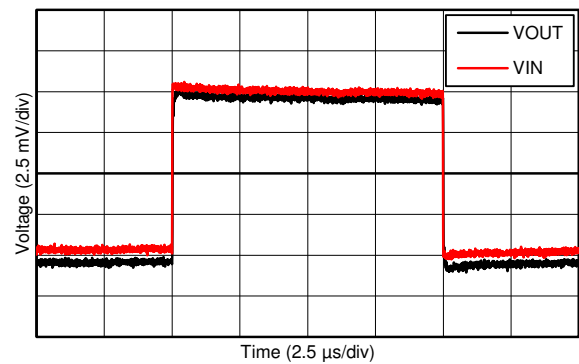

Figure 6-29. Negative Overload Recovery



G = +1

Figure 6-30. Small-Signal Step Response (10-mV Step)

6.8 Typical Characteristics (continued)

at $T_A = 25^\circ\text{C}$, $V_S = \pm 2.5\text{ V}$, $V_{CM} = V_S / 2$, $R_{LOAD} = 10\text{ k}\Omega$ connected to $V_S / 2$, and $C_L = 100\text{ pF}$ (unless otherwise noted)

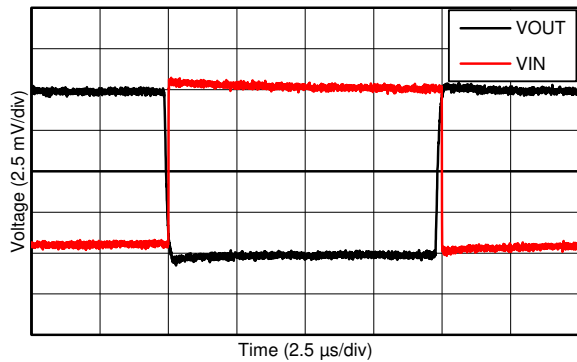

$G = -1$

Figure 6-31. Small-Signal Step Response (10-mV Step)

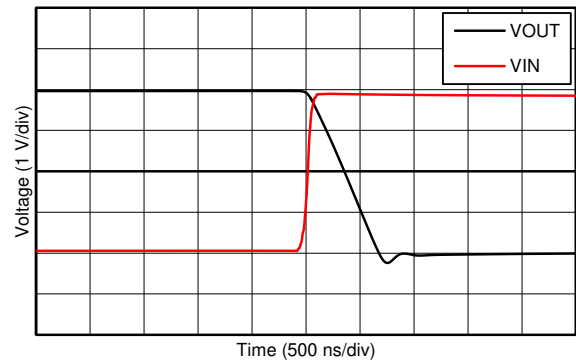

Falling output

Figure 6-32. Large-Signal Step Response (4-V Step)

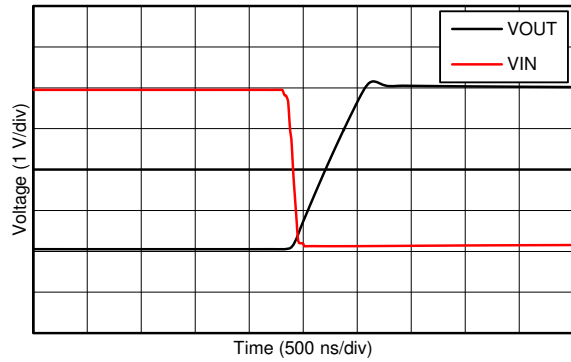

Rising output

Figure 6-33. Large-Signal Step Response (4-V Step)

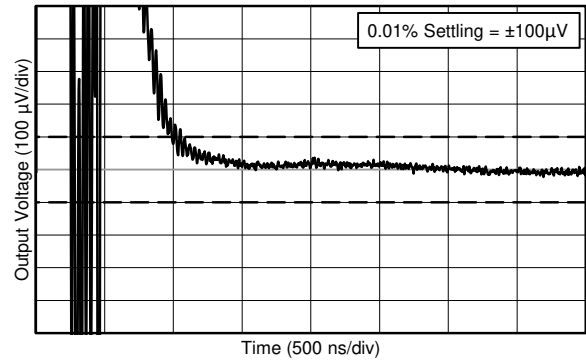

0.01% settling = $\pm 100\ \mu\text{V}$

Figure 6-34. Settling Time (1-V Positive Step)

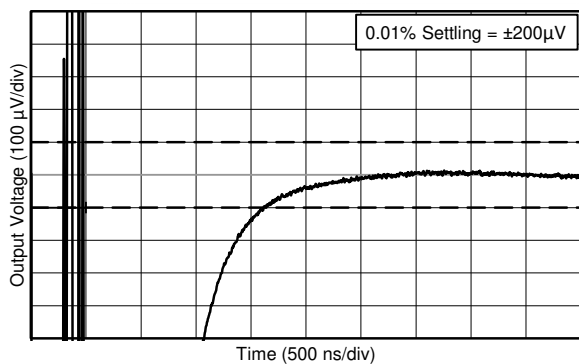

0.01% settling = $\pm 200\ \mu\text{V}$

Figure 6-35. Settling Time (1-V Negative Step)

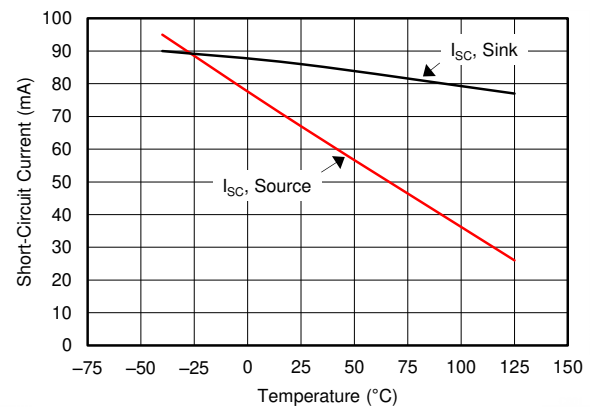

Figure 6-36. Short-Circuit Current vs Temperature

6.8 Typical Characteristics (continued)

at $T_A = 25^\circ\text{C}$, $V_S = \pm 2.5\text{ V}$, $V_{CM} = V_S / 2$, $R_{LOAD} = 10\text{ k}\Omega$ connected to $V_S / 2$, and $C_L = 100\text{ pF}$ (unless otherwise noted)

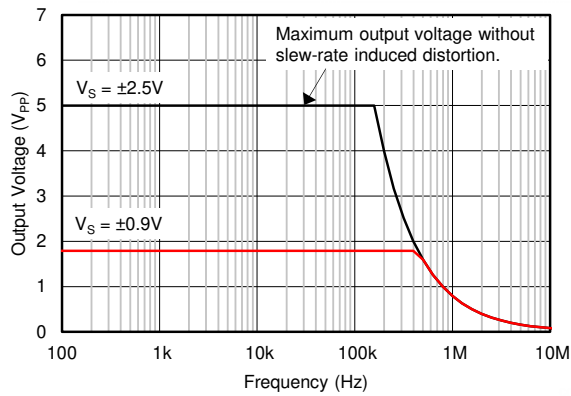

Figure 6-37. Maximum Output Voltage vs Frequency

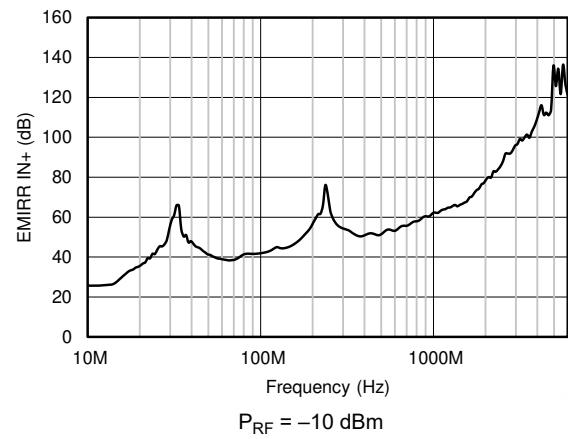

Figure 6-38. EMIRR vs Frequency

7 Detailed Description

7.1 Overview

The OPAx388 family of zero-drift amplifiers is engineered with the unique combination of a proprietary precision auto-calibration technique paired with a low-noise, low-ripple, input charge pump. These amplifiers offer ultra-low input offset voltage and drift and achieve excellent input and output dynamic linearity. The OPAx388 operate from 2.5 V to 5.5 V, is unity-gain stable, and are designed for a wide range of general-purpose and precision applications. The integrated, low-noise charge pump allows true rail-to-rail input common-mode operation without distortion associated with complementary rail-to-rail input topologies (input crossover distortion). The OPAx388 strengths also include 10-MHz bandwidth, $7\text{-nV}/\sqrt{\text{Hz}}$ noise spectral density, and no $1/f$ noise, making the OPAx388 optimal for interfacing with sensor modules and buffering high-fidelity, digital-to-analog converters (DACs).

7.2 Functional Block Diagram

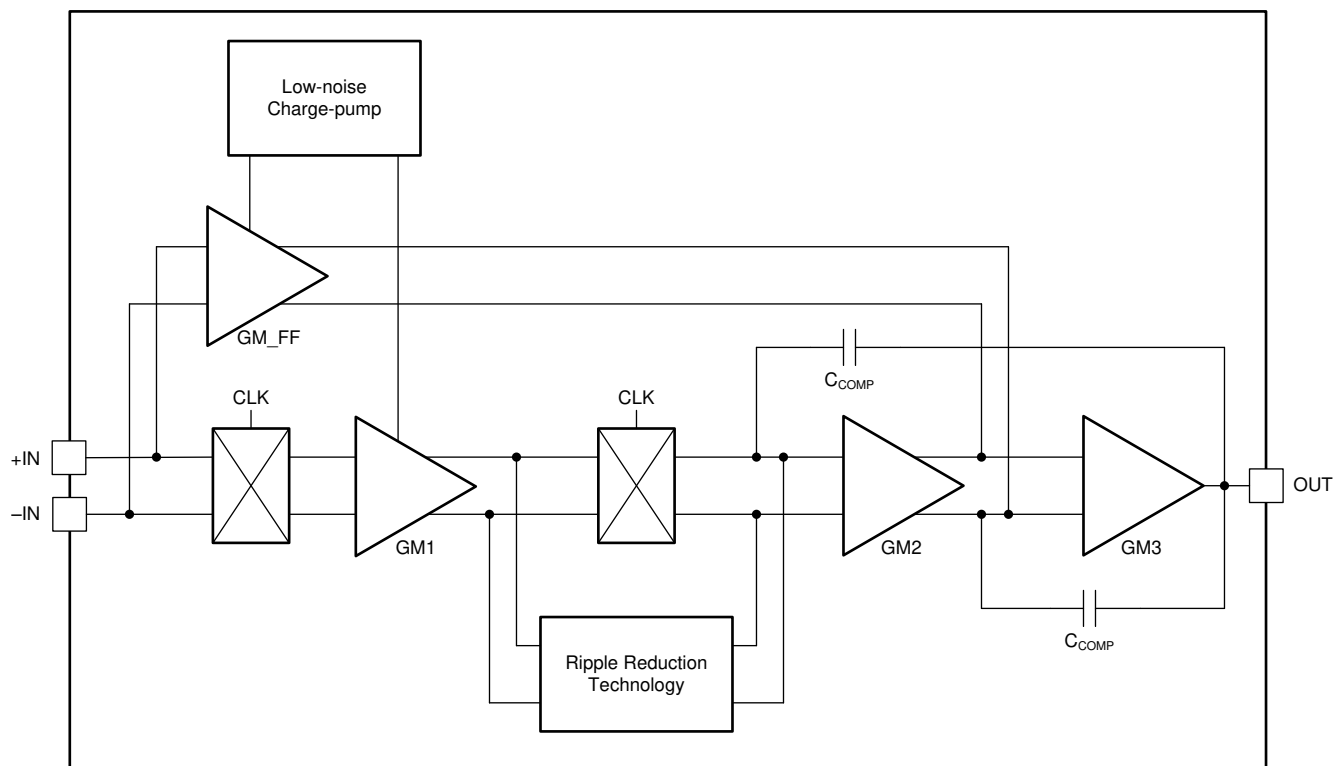

Copyright © 2016, Texas Instruments Incorporated

7.3 Feature Description

7.3.1 Operating Voltage

The OPAx388 family of operational amplifiers can be used with single or dual supplies from an operating range of $V_S = 2.5\text{ V}$ ($\pm 1.25\text{ V}$) up to 5.5 V ($\pm 2.75\text{ V}$). Supply voltages greater than 7 V can permanently damage the device (see the *Absolute Maximum Ratings* table). Key parameters that vary over the supply voltage or temperature range are shown in the *Typical Characteristics* section.

7.3.2 Input Voltage and Zero-Crossover Functionality

The OPAx388 input common-mode voltage range extends 0.1 V beyond the supply rails. This amplifier family is designed to cover the full range without the troublesome transition region found in some other rail-to-rail amplifiers. Operating a complementary rail-to-rail input amplifier with signals traversing the transition region results in unwanted non-linear behavior and polluted spectral content. [Figure 7-1](#) and [Figure 7-2](#) contrast the performance of a traditional complementary rail-to-rail input stage amplifier with the performance of the zero-crossover OPA388. Significant harmonic content and distortion is generated during the differential pair transition (such a transition does not exist in the OPA388). Crossover distortion is eliminated through the use of a single differential pair coupled with an internal low-noise charge pump. The OPAx388 maintains noise, bandwidth, and offset performance throughout the input common-mode range, thus reducing printed circuit board (PCB) and bill of materials (BOM) complexity through the reduction of power-supply rails.

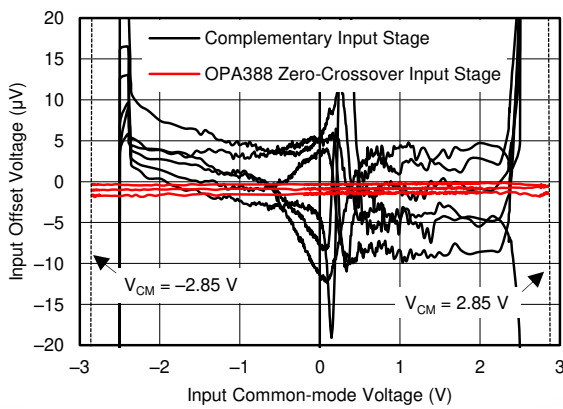

Figure 7-1. Input Crossover Distortion Nonlinearity

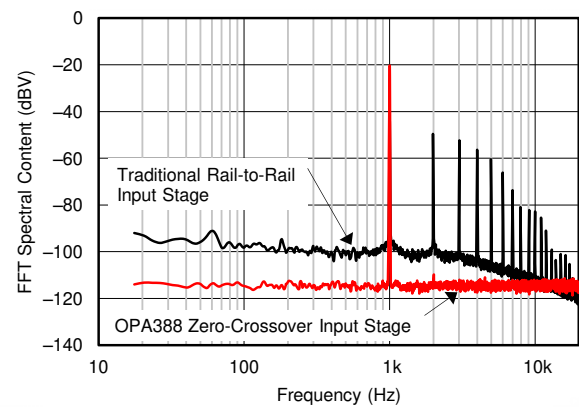

Figure 7-2. Input Crossover Distortion Spectral Content

Typically, input bias current is approximately ± 30 pA. Input voltages exceeding the power supplies, however, can cause excessive current to flow into or out of the input pins. Momentary voltages greater than the power supply can be tolerated if the input current is limited to 10 mA. This limitation is easily accomplished with an input resistor, as shown in Figure 7-3.

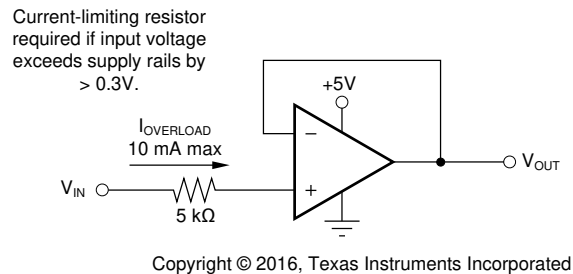

Figure 7-3. Input Current Protection

7.3.3 Input Differential Voltage

The typical input bias current of the OPAx388 during normal operation is approximately 30 pA. In overdriven conditions, the bias current can increase significantly. The most common cause of an overdriven condition occurs when the operational amplifier is outside of the linear range of operation. When the output of the operational amplifier is driven to one of the supply rails, the feedback loop requirements cannot be satisfied and a differential input voltage develops across the input pins. This differential input voltage results in activation of parasitic diodes inside the front-end input chopping switches that combine with 10-kΩ electromagnetic interference (EMI) filter resistors to create the equivalent circuit shown in Figure 7-4. Notice that the input bias current remains within specification in the linear region.

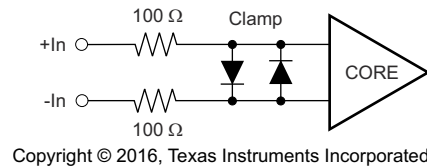

Figure 7-4. Equivalent Input Circuit

7.3.4 Internal Offset Correction

The OPA388 family of operational amplifiers uses an auto-calibration technique with a time-continuous, 200-kHz operational amplifier in the signal path. This amplifier is zero-corrected every 5 μ s using a proprietary technique. At power-up, the amplifier requires approximately 1 ms to achieve the specified V_{OS} accuracy. This design has no aliasing or flicker noise.

7.3.5 EMI Susceptibility and Input Filtering

Operational amplifiers vary in susceptibility to EMI. If conducted EMI enters the operational amplifier, the dc offset at the amplifier output can shift from its nominal value when EMI is present. This shift is a result of signal rectification associated with the internal semiconductor junctions. Although all operational amplifier pin functions can be affected by EMI, the input pins are likely to be the most susceptible. The OPAx388 operational amplifier family incorporates an internal input low-pass filter that reduces the amplifier response to EMI. Both common-mode and differential-mode filtering are provided by the input filter. The filter is designed for a cutoff frequency of approximately 20 MHz (-3 dB), with a rolloff of 20 dB per decade.

7.4 Device Functional Modes

The OPA388 has a single functional mode and is operational when the power-supply voltage is greater than 2.5 V (± 1.25 V). The maximum specified power-supply voltage for the OPAx388 is 5.5 V (± 2.75 V).

8 Application and Implementation

Note

Information in the following applications sections is not part of the TI component specification, and TI does not warrant its accuracy or completeness. TI's customers are responsible for determining suitability of components for their purposes. Customers should validate and test their design implementation to confirm system functionality.

8.1 Application Information

The OPAx388 is a unity-gain stable, precision operational amplifier family free from unexpected output and phase reversal. The use of proprietary zero-drift circuitry gives the benefit of low input offset voltage over time and temperature, as well as lowering the $1/f$ noise component. As a result of the high PSRR, these devices work well in applications that run directly from battery power without regulation. The OPAx388 family is optimized for full rail-to-rail input, allowing for low-voltage, single-supply operation or split-supply use. These miniature, high-precision, low-noise amplifiers offer high-impedance inputs that have a common-mode range 100 mV beyond the supplies without input crossover distortion and a rail-to-rail output that swings within 5 mV of the supplies under normal test conditions. The OPAx388 series of precision amplifiers is designed for upstream analog signal chain applications in low or high gains, as well as downstream signal chain functions such as DAC buffering.

8.2 Typical Applications

8.2.1 Bidirectional Current-Sensing

This single-supply, low-side, bidirectional current-sensing solution detects load currents from -1 A to $+1$ A. The single-ended output spans from 110 mV to 3.19 V. This design uses the OPAx388 because of its low offset voltage and rail-to-rail input and output. One of the amplifiers is configured as a difference amplifier and the other amplifier provides the reference voltage.

Figure 8-1 shows the solution.

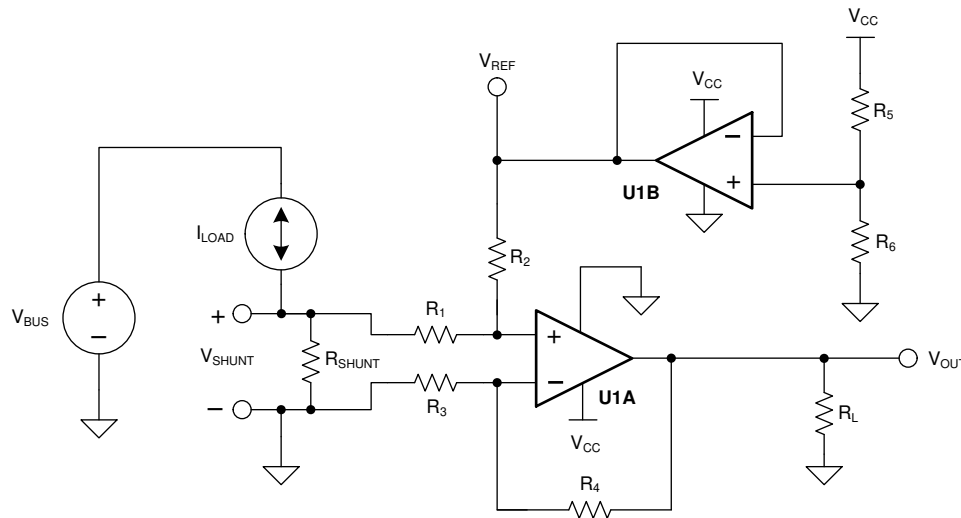

Figure 8-1. Bidirectional Current-Sensing Schematic

8.2.1.1 Design Requirements

This solution has the following requirements:

- Supply voltage: 3.3 V
- Input: –1 A to 1 A
- Output: 1.65 V ±1.54 V (110 mV to 3.19 V)

8.2.1.2 Detailed Design Procedure

The load current, I_{LOAD} , flows through the shunt resistor (R_{SHUNT}) to develop the shunt voltage, V_{SHUNT} . The shunt voltage is then amplified by the difference amplifier consisting of U1A and R_1 through R_4 . The gain of the difference amplifier is set by the ratio of R_4 to R_3 . To minimize errors, set $R_2 = R_4$ and $R_1 = R_3$. The reference voltage, V_{REF} , is supplied by buffering a resistor divider using U1B. The transfer function is given by [Equation 1](#).

$$V_{OUT} = V_{SHUNT} \times \text{Gain}_{\text{Diff_Amp}} + V_{REF} \quad (1)$$

where

- $V_{SHUNT} = I_{LOAD} \times R_{SHUNT}$
- $\text{Gain}_{\text{Diff_Amp}} = \frac{R_4}{R_3}$
- $V_{REF} = V_{CC} \times \left[\frac{R_6}{R_5 + R_6} \right]$

There are two types of errors in this design: offset and gain. Gain errors are introduced by the tolerance of the shunt resistor and the ratios of R_4 to R_3 and, similarly, R_2 to R_1 . Offset errors are introduced by the voltage divider (R_5 and R_6) and how closely the ratio of R_4 / R_3 matches R_2 / R_1 . The latter value affects the CMRR of the difference amplifier, ultimately translating to an offset error.

The value of V_{SHUNT} is the ground potential for the system load because V_{SHUNT} is a low-side measurement. Therefore, a maximum value must be placed on V_{SHUNT} . In this design, the maximum value for V_{SHUNT} is set to 100 mV. [Equation 2](#) calculates the maximum value of the shunt resistor given a maximum shunt voltage of 100 mV and maximum load current of 1 A.

$$R_{SHUNT(\text{Max})} = \frac{V_{SHUNT(\text{Max})}}{I_{LOAD(\text{Max})}} = \frac{100 \text{ mV}}{1 \text{ A}} = 100 \text{ m}\Omega \quad (2)$$

The tolerance of R_{SHUNT} is directly proportional to cost. For this design, a shunt resistor with a tolerance of 0.5% was selected. If greater accuracy is required, select a 0.1% resistor or better.

The load current is bidirectional; therefore, the shunt voltage range is –100 mV to 100 mV. This voltage is divided down by R_1 and R_2 before reaching the operational amplifier, U1A. Make sure that the voltage present at the noninverting node of U1A is within the common-mode range of the device. Therefore, use an operational amplifier, such as the OPA388, that has a common-mode range that extends below the negative supply voltage. Finally, to minimize offset error, note that the OPA388 has a typical offset voltage of merely ±0.25 μV (±5 μV maximum).

Given a symmetric load current of –1 A to 1 A, the voltage divider resistors (R_5 and R_6) must be equal. To be consistent with the shunt resistor, a tolerance of 0.5% was selected. To minimize power consumption, 10-kΩ resistors were used.

To set the gain of the difference amplifier, the common-mode range and output swing of the OPA388 must be considered. Equation 3 and Equation 4 depict the typical common-mode range and maximum output swing, respectively, of the OPA388 given a 3.3-V supply.

$$-100 \text{ mV} < V_{\text{CM}} < 3.4 \text{ V} \tag{3}$$

$$100 \text{ mV} < V_{\text{OUT}} < 3.2 \text{ V} \tag{4}$$

The gain of the difference amplifier can now be calculated as shown in Equation 5.

$$\text{Gain}_{\text{Diff_Amp}} = \frac{V_{\text{OUT_Max}} - V_{\text{OUT_Min}}}{R_{\text{SHUNT}} \times (I_{\text{MAX}} - I_{\text{MIN}})} = \frac{3.2 \text{ V} - 100 \text{ mV}}{100 \text{ m}\Omega \times [1 \text{ A} - (-1 \text{ A})]} = 15.5 \frac{\text{V}}{\text{V}} \tag{5}$$

The resistor value selected for R₁ and R₃ was 1 kΩ. 15.4 kΩ was selected for R₂ and R₄ because this number is the nearest standard value. Therefore, the ideal gain of the difference amplifier is 15.4 V/V.

The gain error of the circuit primarily depends on R₁ through R₄. As a result of this dependence, 0.1% resistors were selected. This configuration reduces the likelihood that the design requires a two-point calibration. A simple one-point calibration, if desired, removes the offset errors introduced by the 0.5% resistors.

8.2.1.3 Application Curve

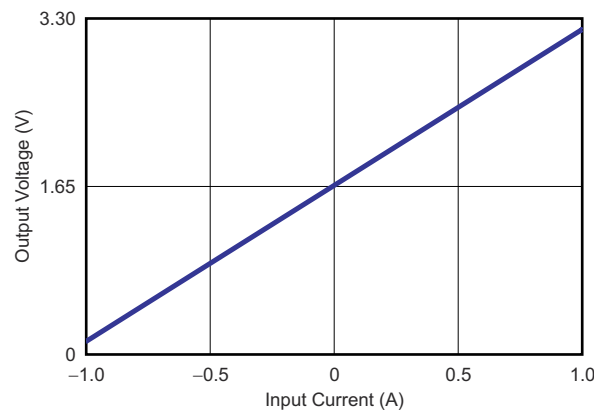
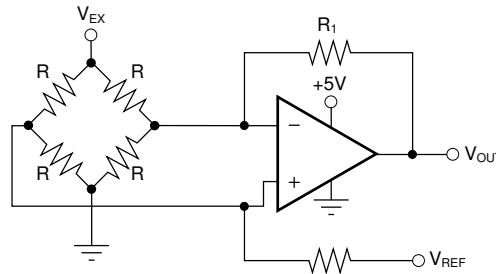

Figure 8-2. Bidirectional Current-Sensing Circuit Performance: Output Voltage vs Input Current

8.2.2 Single Operational Amplifier Bridge Amplifier

Figure 8-3 shows the basic configuration for a bridge amplifier.



Copyright © 2016, Texas Instruments Incorporated

Figure 8-3. Single Operational Amplifier Bridge Amplifier Schematic

8.2.3 Precision, Low-Noise, DAC Buffer

The OPA388 can be used for a precision DAC buffer, as shown in Figure 8-4, in conjunction with the DAC8830.

The OPA388 provides an ultra-low drift, precision output buffer for the DAC. A wide range of DAC codes can be used in the linear region because the OPA388 employs zero-crossover technology. A precise reference is essential for maximum accuracy because the DAC8830 is a 16-bit converter.

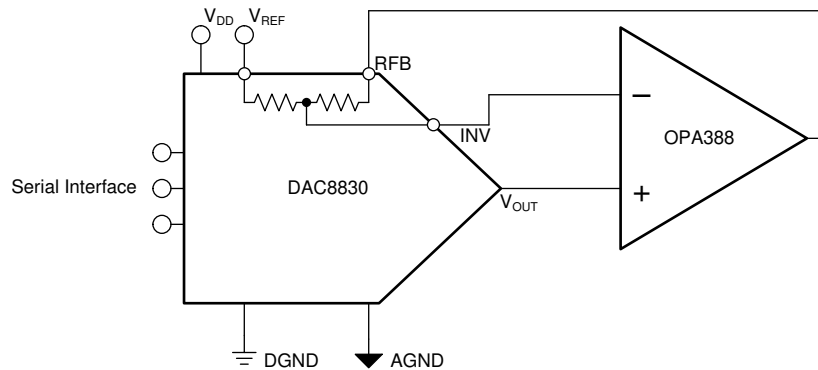

Copyright © 2016, Texas Instruments Incorporated

Figure 8-4. Precision DAC Buffer

8.2.4 Load Cell Measurement

Figure 8-5 shows the OPA388 in a high-CMRR dual-op amp instrumentation amplifier with a trim resistor and 6-wire load cell for precision measurement. Figure 8-6 illustrates the output voltage as a function of load cell resistance change, along with the nonlinearity of the system.

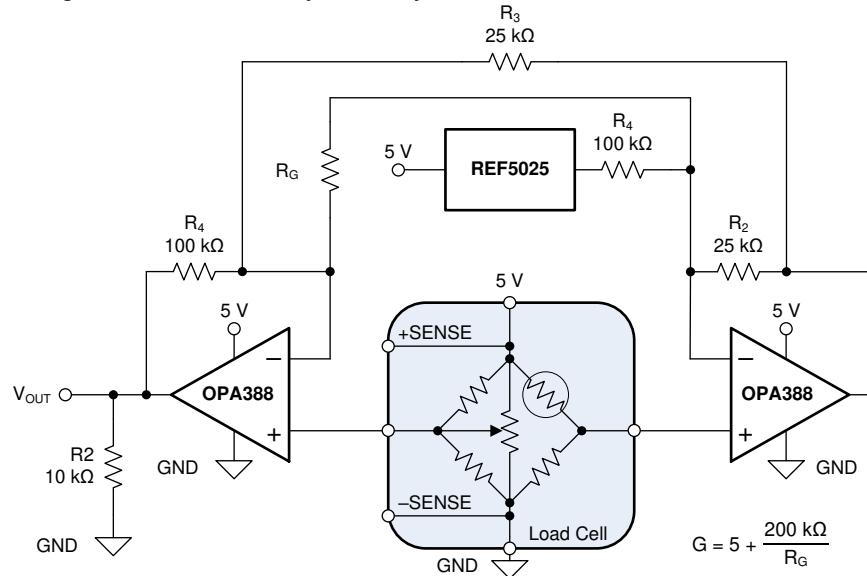

Figure 8-5. Load Cell Measurement Schematic

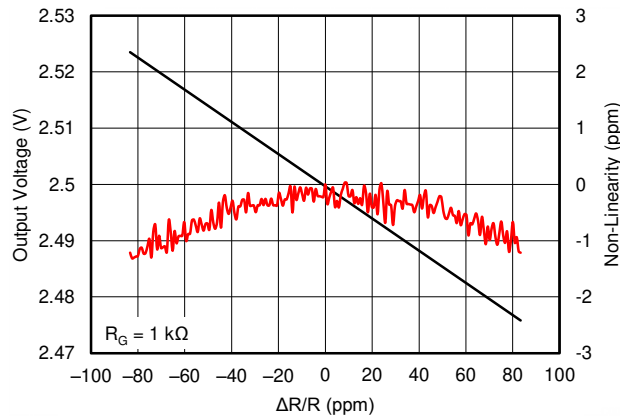

Figure 8-6. Load Cell Measurement Output

9 Power Supply Recommendations

The OPAx388 family of devices is specified for operation from 2.5 V to 5.5 V ($\pm 1.25 \text{ V}$ to $\pm 2.75 \text{ V}$). Parameters that can exhibit significant variance with regard to operating voltage are presented in the *Typical Characteristics* section.

10 Layout

10.1 Layout Guidelines

Paying attention to good layout practice is always recommended. Keep traces short and, when possible, use a printed-circuit board (PCB) ground plane with surface-mount components placed as close to the device pins as possible. Place a 0.1- μF capacitor closely across the supply pins. These guidelines must be applied throughout the analog circuit to improve performance and provide benefits such as reducing the electromagnetic interference (EMI) susceptibility.

For lowest offset voltage and precision performance, circuit layout and mechanical conditions must be optimized. Avoid temperature gradients that create thermoelectric (Seebeck) effects in the thermocouple junctions formed from connecting dissimilar conductors. These thermally-generated potentials can be made to cancel by assuring they are equal on both input terminals. Other layout and design considerations include:

- Use low thermoelectric-coefficient conditions (avoid dissimilar metals).
- Thermally isolate components from power supplies or other heat sources.
- Shield operational amplifier and input circuitry from air currents, such as cooling fans.

Following these guidelines reduces the likelihood of junctions being at different temperatures, which can cause thermoelectric voltage drift of 0.1 $\mu\text{V}/^\circ\text{C}$ or higher, depending on materials used.

10.2 Layout Example

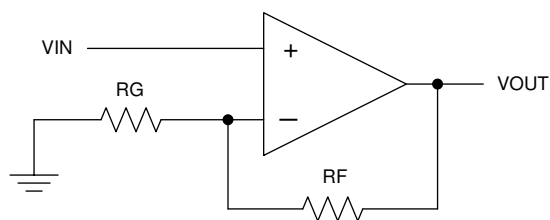

Figure 10-1. Schematic Representation

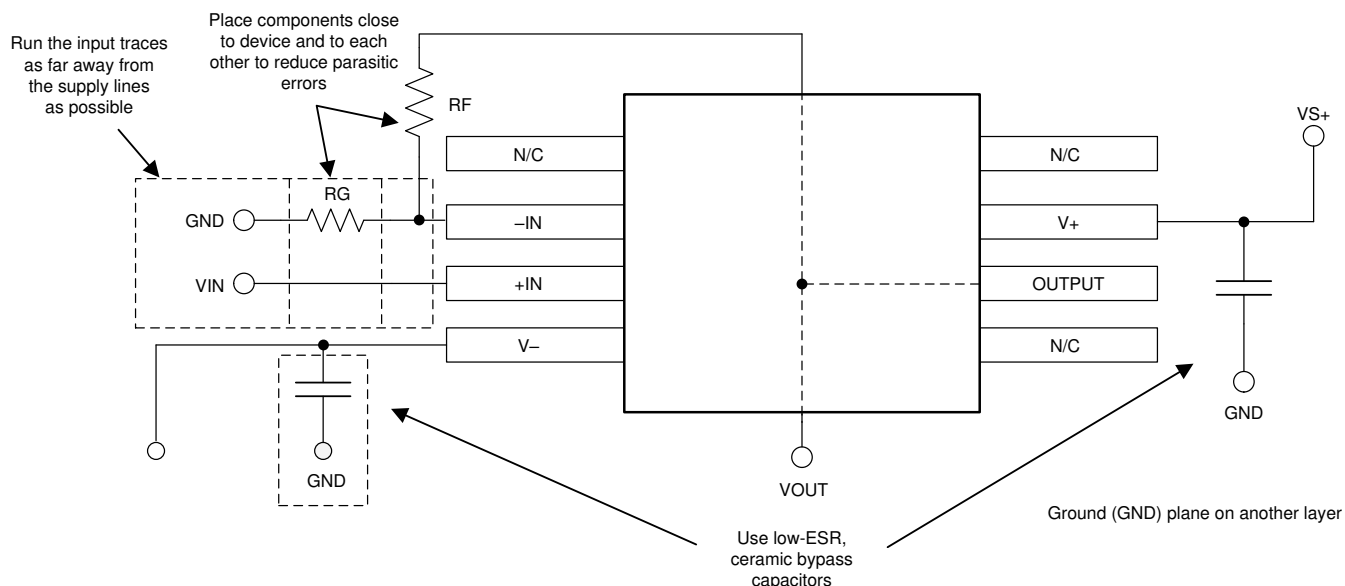

Figure 10-2. OPA388 Layout Example

11 Device and Documentation Support

11.1 Device Support

11.1.1 Development Support

11.1.1.1 TINA-TI™ Simulation Software (Free Download)

TINA-TI™ simulation software is a simple, powerful, and easy-to-use circuit simulation program based on a SPICE engine. TINA-TI simulation software is a free, fully-functional version of the TINA™ software, preloaded with a library of macromodels, in addition to a range of both passive and active models. TINA-TI simulation software provides all the conventional dc, transient, and frequency domain analysis of SPICE, as well as additional design capabilities.

Available as a [free download](#) from the Analog eLab Design Center, TINA-TI simulation software offers extensive post-processing capability that allows users to format results in a variety of ways. Virtual instruments offer the ability to select input waveforms and probe circuit nodes, voltages, and waveforms, creating a dynamic quick-start tool.

Note

These files require that either the TINA software or TINA-TI software be installed. Download the free TINA-TI simulation software from the [TINA-TI™ software folder](#).

11.1.1.2 TI Precision Designs

The OPAx388 family is featured on TI Precision Designs, available online at www.ti.com/ww/en/analog/precision-designs/. TI Precision Designs are analog solutions created by TI's precision analog applications experts and offer the theory of operation, component selection, simulation, complete PCB schematic and layout, bill of materials, and measured performance of many useful circuits.

11.2 Documentation Support

11.2.1 Related Documentation

For related documentation see the following:

- Texas Instruments, [Circuit board layout techniques](#)
- Texas Instruments, [DAC883x 16-Bit, Ultra-Low Power, Voltage-Output Digital-to-Analog Converters data sheet](#)

11.3 Related Links

[Table 11-1](#) lists quick access links. Categories include technical documents, support and community resources, tools and software, and quick access to sample or buy.

Table 11-1. Related Links

PARTS	PRODUCT FOLDER	SAMPLE & BUY	TECHNICAL DOCUMENTS	TOOLS & SOFTWARE	SUPPORT & COMMUNITY
OPA388	Click here	Click here	Click here	Click here	Click here
OPA2388	Click here	Click here	Click here	Click here	Click here
OPA4388	Click here	Click here	Click here	Click here	Click here

11.4 Receiving Notification of Documentation Updates

To receive notification of documentation updates, navigate to the device product folder on ti.com. Click on [Subscribe to updates](#) to register and receive a weekly digest of any product information that has changed. For change details, review the revision history included in any revised document.

11.5 Support Resources

[TI E2E™ support forums](#) are an engineer's go-to source for fast, verified answers and design help — straight from the experts. Search existing answers or ask your own question to get the quick design help you need.

Linked content is provided "AS IS" by the respective contributors. They do not constitute TI specifications and do not necessarily reflect TI's views; see TI's [Terms of Use](#).

11.6 Trademarks

TINA-TI™ and TI E2E™ are trademarks of Texas Instruments.

TINA™ is a trademark of DesignSoft, Inc.

All trademarks are the property of their respective owners.

11.7 Electrostatic Discharge Caution



This integrated circuit can be damaged by ESD. Texas Instruments recommends that all integrated circuits be handled with appropriate precautions. Failure to observe proper handling and installation procedures can cause damage.

ESD damage can range from subtle performance degradation to complete device failure. Precision integrated circuits may be more susceptible to damage because very small parametric changes could cause the device not to meet its published specifications.

11.8 Glossary

[TI Glossary](#) This glossary lists and explains terms, acronyms, and definitions.

12 Mechanical, Packaging, and Orderable Information

The following pages include mechanical packaging and orderable information. This information is the most current data available for the designated devices. This data is subject to change without notice and revision of this document. For browser-based versions of this data sheet, refer to the left-hand navigation.

PACKAGING INFORMATION

Orderable part number	Status (1)	Material type (2)	Package Pins	Package qty Carrier	RoHS (3)	Lead finish/ Ball material (4)	MSL rating/ Peak reflow (5)	Op temp (°C)	Part marking (6)
OPA2388ID	Active	Production	SOIC (D) 8	75 TUBE	Yes	SN	Level-2-260C-1 YEAR	-40 to 125	OP2388
OPA2388IDGKR	Active	Production	VSSOP (DGK) 8	2500 LARGE T&R	Yes	NIPDAUAG SN	Level-2-260C-1 YEAR	-40 to 125	1D36
OPA2388IDGKT	Active	Production	VSSOP (DGK) 8	250 SMALL T&R	Yes	NIPDAUAG SN	Level-2-260C-1 YEAR	-40 to 125	1D36
OPA2388IDR	Active	Production	SOIC (D) 8	2500 LARGE T&R	Yes	SN	Level-2-260C-1 YEAR	-40 to 125	OP2388
OPA388ID	Active	Production	SOIC (D) 8	75 TUBE	Yes	NIPDAU	Level-2-260C-1 YEAR	-40 to 125	OPA388
OPA388IDBVR	Active	Production	SOT-23 (DBV) 5	3000 LARGE T&R	Yes	NIPDAU	Level-2-260C-1 YEAR	-40 to 125	14KV
OPA388IDBVT	Active	Production	SOT-23 (DBV) 5	250 SMALL T&R	Yes	NIPDAU	Level-2-260C-1 YEAR	-40 to 125	14KV
OPA388IDGKR	Active	Production	VSSOP (DGK) 8	2500 LARGE T&R	Yes	NIPDAUAG	Level-2-260C-1 YEAR	-40 to 125	14LV
OPA388IDGKT	Active	Production	VSSOP (DGK) 8	250 SMALL T&R	Yes	NIPDAUAG	Level-2-260C-1 YEAR	-40 to 125	14LV
OPA388IDR	Active	Production	SOIC (D) 8	2500 LARGE T&R	Yes	NIPDAU	Level-2-260C-1 YEAR	-40 to 125	OPA388
OPA4388ID	Active	Production	SOIC (D) 14	50 TUBE	Yes	NIPDAU	Level-2-260C-1 YEAR	-40 to 125	OPA4388
OPA4388IDR	Active	Production	SOIC (D) 14	2500 LARGE T&R	Yes	NIPDAU	Level-2-260C-1 YEAR	-40 to 125	OPA4388
OPA4388IPW	Active	Production	TSSOP (PW) 14	90 TUBE	Yes	NIPDAU	Level-2-260C-1 YEAR	-40 to 125	OPA4388
OPA4388IPWR	Active	Production	TSSOP (PW) 14	2000 LARGE T&R	Yes	NIPDAU	Level-2-260C-1 YEAR	-40 to 125	OPA4388

(1) **Status:** For more details on status, see our [product life cycle](#).

(2) **Material type:** When designated, preproduction parts are prototypes/experimental devices, and are not yet approved or released for full production. Testing and final process, including without limitation quality assurance, reliability performance testing, and/or process qualification, may not yet be complete, and this item is subject to further changes or possible discontinuation. If available for ordering, purchases will be subject to an additional waiver at checkout, and are intended for early internal evaluation purposes only. These items are sold without warranties of any kind.

(3) **RoHS values:** Yes, No, RoHS Exempt. See the [TI RoHS Statement](#) for additional information and value definition.

(4) **Lead finish/Ball material:** Parts may have multiple material finish options. Finish options are separated by a vertical ruled line. Lead finish/Ball material values may wrap to two lines if the finish value exceeds the maximum column width.

(5) **MSL rating/Peak reflow:** The moisture sensitivity level ratings and peak solder (reflow) temperatures. In the event that a part has multiple moisture sensitivity ratings, only the lowest level per JEDEC standards is shown. Refer to the shipping label for the actual reflow temperature that will be used to mount the part to the printed circuit board.

(6) **Part marking:** There may be an additional marking, which relates to the logo, the lot trace code information, or the environmental category of the part.

Multiple part markings will be inside parentheses. Only one part marking contained in parentheses and separated by a "~" will appear on a part. If a line is indented then it is a continuation of the previous line and the two combined represent the entire part marking for that device.

Important Information and Disclaimer:The information provided on this page represents TI's knowledge and belief as of the date that it is provided. TI bases its knowledge and belief on information provided by third parties, and makes no representation or warranty as to the accuracy of such information. Efforts are underway to better integrate information from third parties. TI has taken and continues to take reasonable steps to provide representative and accurate information but may not have conducted destructive testing or chemical analysis on incoming materials and chemicals. TI and TI suppliers consider certain information to be proprietary, and thus CAS numbers and other limited information may not be available for release.

In no event shall TI's liability arising out of such information exceed the total purchase price of the TI part(s) at issue in this document sold by TI to Customer on an annual basis.

OTHER QUALIFIED VERSIONS OF OPA2388, OPA388 :

- Automotive : [OPA2388-Q1](#), [OPA388-Q1](#)

NOTE: Qualified Version Definitions:

- Automotive - Q100 devices qualified for high-reliability automotive applications targeting zero defects

TAPE AND REEL INFORMATION

QUADRANT ASSIGNMENTS FOR PIN 1 ORIENTATION IN TAPE

*All dimensions are nominal

Device	Package Type	Package Drawing	Pins	SPQ	Reel Diameter (mm)	Reel Width W1 (mm)	A0 (mm)	B0 (mm)	K0 (mm)	P1 (mm)	W (mm)	Pin1 Quadrant
OPA2388IDGKR	VSSOP	DGK	8	2500	330.0	12.4	5.25	3.35	1.25	8.0	12.0	Q1
OPA2388IDGKT	VSSOP	DGK	8	250	330.0	12.4	5.25	3.35	1.25	8.0	12.0	Q1
OPA2388IDR	SOIC	D	8	2500	330.0	12.8	6.4	5.2	2.1	8.0	12.0	Q1
OPA388IDBVR	SOT-23	DBV	5	3000	180.0	8.4	3.23	3.17	1.37	4.0	8.0	Q3
OPA388IDBVT	SOT-23	DBV	5	250	180.0	8.4	3.23	3.17	1.37	4.0	8.0	Q3
OPA388IDGKR	VSSOP	DGK	8	2500	330.0	12.4	5.3	3.4	1.4	8.0	12.0	Q1
OPA388IDGKT	VSSOP	DGK	8	250	330.0	12.4	5.3	3.4	1.4	8.0	12.0	Q1
OPA388IDR	SOIC	D	8	2500	330.0	12.4	6.4	5.2	2.1	8.0	12.0	Q1
OPA4388IDR	SOIC	D	14	2500	330.0	16.4	6.5	9.0	2.1	8.0	16.0	Q1
OPA4388IPWR	TSSOP	PW	14	2000	330.0	12.4	6.9	5.6	1.6	8.0	12.0	Q1

TAPE AND REEL BOX DIMENSIONS

*All dimensions are nominal

Device	Package Type	Package Drawing	Pins	SPQ	Length (mm)	Width (mm)	Height (mm)
OPA2388IDGKR	VSSOP	DGK	8	2500	366.0	364.0	50.0
OPA2388IDGKT	VSSOP	DGK	8	250	366.0	364.0	50.0
OPA2388IDR	SOIC	D	8	2500	366.0	364.0	50.0
OPA388IDBVR	SOT-23	DBV	5	3000	213.0	191.0	35.0
OPA388IDBVT	SOT-23	DBV	5	250	213.0	191.0	35.0
OPA388IDGKR	VSSOP	DGK	8	2500	366.0	364.0	50.0
OPA388IDGKT	VSSOP	DGK	8	250	366.0	364.0	50.0
OPA388IDR	SOIC	D	8	2500	356.0	356.0	35.0
OPA4388IDR	SOIC	D	14	2500	356.0	356.0	35.0
OPA4388IPWR	TSSOP	PW	14	2000	356.0	356.0	35.0

TUBE

*All dimensions are nominal

Device	Package Name	Package Type	Pins	SPQ	L (mm)	W (mm)	T (μm)	B (mm)
OPA2388ID	D	SOIC	8	75	517	7.87	635	4.25
OPA388ID	D	SOIC	8	75	506.6	8	3940	4.32
OPA4388ID	D	SOIC	14	50	506.6	8	3940	4.32
OPA4388IPW	PW	TSSOP	14	90	530	10.2	3600	3.5

EXAMPLE BOARD LAYOUT

DBV0005A

SOT-23 - 1.45 mm max height

SMALL OUTLINE TRANSISTOR



LAND PATTERN EXAMPLE
EXPOSED METAL SHOWN
SCALE:15X



SOLDER MASK DETAILS

4214839/K 08/2024

NOTES: (continued)

- 6. Publication IPC-7351 may have alternate designs.
- 7. Solder mask tolerances between and around signal pads can vary based on board fabrication site.

EXAMPLE STENCIL DESIGN

DBV0005A

SOT-23 - 1.45 mm max height

SMALL OUTLINE TRANSISTOR



SOLDER PASTE EXAMPLE
BASED ON 0.125 mm THICK STENCIL
SCALE:15X

4214839/K 08/2024

NOTES: (continued)

8. Laser cutting apertures with trapezoidal walls and rounded corners may offer better paste release. IPC-7525 may have alternate design recommendations.
9. Board assembly site may have different recommendations for stencil design.

DGK0008A



PACKAGE OUTLINE

VSSOP - 1.1 mm max height

SMALL OUTLINE PACKAGE



4214862/A 04/2023

NOTES:

PowerPAD is a trademark of Texas Instruments.

1. All linear dimensions are in millimeters. Any dimensions in parenthesis are for reference only. Dimensioning and tolerancing per ASME Y14.5M.
2. This drawing is subject to change without notice.
3. This dimension does not include mold flash, protrusions, or gate burrs. Mold flash, protrusions, or gate burrs shall not exceed 0.15 mm per side.
4. This dimension does not include interlead flash. Interlead flash shall not exceed 0.25 mm per side.
5. Reference JEDEC registration MO-187.

EXAMPLE BOARD LAYOUT

DGK0008A

™ VSSOP - 1.1 mm max height

SMALL OUTLINE PACKAGE



LAND PATTERN EXAMPLE
EXPOSED METAL SHOWN
SCALE: 15X



SOLDER MASK DETAILS

4214862/A 04/2023

NOTES: (continued)

6. Publication IPC-7351 may have alternate designs.
7. Solder mask tolerances between and around signal pads can vary based on board fabrication site.
8. Vias are optional depending on application, refer to device data sheet. If any vias are implemented, refer to their locations shown on this view. It is recommended that vias under paste be filled, plugged or tented.
9. Size of metal pad may vary due to creepage requirement.

EXAMPLE STENCIL DESIGN

DGK0008A

™ VSSOP - 1.1 mm max height

SMALL OUTLINE PACKAGE



SOLDER PASTE EXAMPLE
SCALE: 15X

4214862/A 04/2023

NOTES: (continued)

11. Laser cutting apertures with trapezoidal walls and rounded corners may offer better paste release. IPC-7525 may have alternate design recommendations.
12. Board assembly site may have different recommendations for stencil design.



D0014A

PACKAGE OUTLINE

SOIC - 1.75 mm max height

SMALL OUTLINE INTEGRATED CIRCUIT



4220718/A 09/2016

NOTES:

1. All linear dimensions are in millimeters. Dimensions in parenthesis are for reference only. Dimensioning and tolerancing per ASME Y14.5M.
2. This drawing is subject to change without notice.
3. This dimension does not include mold flash, protrusions, or gate burrs. Mold flash, protrusions, or gate burrs shall not exceed 0.15 mm, per side.
4. This dimension does not include interlead flash. Interlead flash shall not exceed 0.43 mm, per side.
5. Reference JEDEC registration MS-012, variation AB.

EXAMPLE BOARD LAYOUT

D0014A

SOIC - 1.75 mm max height

SMALL OUTLINE INTEGRATED CIRCUIT



LAND PATTERN EXAMPLE
SCALE:8X



SOLDER MASK DETAILS

4220718/A 09/2016

NOTES: (continued)

- 6. Publication IPC-7351 may have alternate designs.
- 7. Solder mask tolerances between and around signal pads can vary based on board fabrication site.

EXAMPLE STENCIL DESIGN

D0014A

SOIC - 1.75 mm max height

SMALL OUTLINE INTEGRATED CIRCUIT



SOLDER PASTE EXAMPLE
BASED ON 0.125 mm THICK STENCIL
SCALE:8X

4220718/A 09/2016

NOTES: (continued)

8. Laser cutting apertures with trapezoidal walls and rounded corners may offer better paste release. IPC-7525 may have alternate design recommendations.
9. Board assembly site may have different recommendations for stencil design.



D0008A

PACKAGE OUTLINE

SOIC - 1.75 mm max height

SMALL OUTLINE INTEGRATED CIRCUIT



NOTES:

1. Linear dimensions are in inches [millimeters]. Dimensions in parenthesis are for reference only. Controlling dimensions are in inches. Dimensioning and tolerancing per ASME Y14.5M.
2. This drawing is subject to change without notice.
3. This dimension does not include mold flash, protrusions, or gate burrs. Mold flash, protrusions, or gate burrs shall not exceed $.006$ [0.15] per side.
4. This dimension does not include interlead flash.
5. Reference JEDEC registration MS-012, variation AA.

EXAMPLE BOARD LAYOUT

D0008A

SOIC - 1.75 mm max height

SMALL OUTLINE INTEGRATED CIRCUIT



LAND PATTERN EXAMPLE
EXPOSED METAL SHOWN
SCALE:8X



SOLDER MASK DETAILS

4214825/C 02/2019

NOTES: (continued)

- 6. Publication IPC-7351 may have alternate designs.
- 7. Solder mask tolerances between and around signal pads can vary based on board fabrication site.

EXAMPLE STENCIL DESIGN

D0008A

SOIC - 1.75 mm max height

SMALL OUTLINE INTEGRATED CIRCUIT



SOLDER PASTE EXAMPLE
BASED ON .005 INCH [0.125 MM] THICK STENCIL
SCALE:8X

4214825/C 02/2019

NOTES: (continued)

8. Laser cutting apertures with trapezoidal walls and rounded corners may offer better paste release. IPC-7525 may have alternate design recommendations.
9. Board assembly site may have different recommendations for stencil design.

PW0014A



PACKAGE OUTLINE
TSSOP - 1.2 mm max height

SMALL OUTLINE PACKAGE



4220202/B 12/2023

NOTES:

1. All linear dimensions are in millimeters. Any dimensions in parenthesis are for reference only. Dimensioning and tolerancing per ASME Y14.5M.
2. This drawing is subject to change without notice.
3. This dimension does not include mold flash, protrusions, or gate burrs. Mold flash, protrusions, or gate burrs shall not exceed 0.15 mm per side.
4. This dimension does not include interlead flash. Interlead flash shall not exceed 0.25 mm per side.
5. Reference JEDEC registration MO-153.

EXAMPLE BOARD LAYOUT

PW0014A

TSSOP - 1.2 mm max height

SMALL OUTLINE PACKAGE



LAND PATTERN EXAMPLE
EXPOSED METAL SHOWN
SCALE: 10X



4220202/B 12/2023

NOTES: (continued)

- 6. Publication IPC-7351 may have alternate designs.
- 7. Solder mask tolerances between and around signal pads can vary based on board fabrication site.

EXAMPLE STENCIL DESIGN

PW0014A

TSSOP - 1.2 mm max height

SMALL OUTLINE PACKAGE



SOLDER PASTE EXAMPLE
BASED ON 0.125 mm THICK STENCIL
SCALE: 10X

4220202/B 12/2023

NOTES: (continued)

8. Laser cutting apertures with trapezoidal walls and rounded corners may offer better paste release. IPC-7525 may have alternate design recommendations.
9. Board assembly site may have different recommendations for stencil design.

IMPORTANT NOTICE AND DISCLAIMER

TI PROVIDES TECHNICAL AND RELIABILITY DATA (INCLUDING DATA SHEETS), DESIGN RESOURCES (INCLUDING REFERENCE DESIGNS), APPLICATION OR OTHER DESIGN ADVICE, WEB TOOLS, SAFETY INFORMATION, AND OTHER RESOURCES "AS IS" AND WITH ALL FAULTS, AND DISCLAIMS ALL WARRANTIES, EXPRESS AND IMPLIED, INCLUDING WITHOUT LIMITATION ANY IMPLIED WARRANTIES OF MERCHANTABILITY, FITNESS FOR A PARTICULAR PURPOSE OR NON-INFRINGEMENT OF THIRD PARTY INTELLECTUAL PROPERTY RIGHTS.

These resources are intended for skilled developers designing with TI products. You are solely responsible for (1) selecting the appropriate TI products for your application, (2) designing, validating and testing your application, and (3) ensuring your application meets applicable standards, and any other safety, security, regulatory or other requirements.

These resources are subject to change without notice. TI grants you permission to use these resources only for development of an application that uses the TI products described in the resource. Other reproduction and display of these resources is prohibited. No license is granted to any other TI intellectual property right or to any third party intellectual property right. TI disclaims responsibility for, and you will fully indemnify TI and its representatives against, any claims, damages, costs, losses, and liabilities arising out of your use of these resources.

TI's products are provided subject to [TI's Terms of Sale](#) or other applicable terms available either on [ti.com](https://www.ti.com) or provided in conjunction with such TI products. TI's provision of these resources does not expand or otherwise alter TI's applicable warranties or warranty disclaimers for TI products.

TI objects to and rejects any additional or different terms you may have proposed.

Mailing Address: Texas Instruments, Post Office Box 655303, Dallas, Texas 75265

Copyright © 2025, Texas Instruments Incorporated

Looking for pricing, stock, or lifecycle information?

Click below to explore more details on WIN SOURCE:

 [View OPA2388ID](#) on WIN SOURCE

 [Texas Instruments](#) Information

Optimize Your Supply Chain with WIN SOURCE Solutions

-  Global Sourcing Solution
-  Obsolete Management
-  Cost Control Management
-  Shortage Management
-  Alternative Solution
-  Excess Inventory Management