



**THE DATASHEET OF
ADRF5144BCCZN**



10 W Average, Silicon SPDT, Reflective Switch, 1 GHz to 20 GHz

FEATURES

- ▶ Wideband frequency range: 1 GHz to 20 GHz
- ▶ Low insertion loss: 0.8 dB typical to 20 GHz
- ▶ High Isolation: 52 dB typical to 20 GHz
- ▶ High input linearity
 - ▶ 0.1 dB power compression (P0.1dB): 44 dBm
 - ▶ Third order intercept (IP3): >70 dBm
 - ▶ Second order intercept (IP2): >120 dBm
- ▶ High power handling at T_{CASE} = 85°C:
 - ▶ Insertion loss path
 - ▶ Average: 40 dBm
 - ▶ Pulsed (>100 ns pulse width, 15% duty cycle): 43 dBm
 - ▶ Peak (≤100 ns peak duration, 5% duty cycle): 44 dBm
 - ▶ Hot-switching: 37 dBm
- ▶ 0.1 dB RF settling time with P_{IN} ≤ 37 dBm: 750 ns
- ▶ No low frequency spurious
- ▶ Positive control interface: CMOS/LVTTL-compatible
- ▶ 20-lead, 3.0 mm × 3.0 mm LGA package
- ▶ Pin compatible with ADRF5141

APPLICATIONS

- ▶ Military radios, radars, and electronic counter measures
- ▶ Satcom
- ▶ Test and instrumentation
- ▶ GaN and PIN diode replacement

FUNCTIONAL BLOCK DIAGRAM

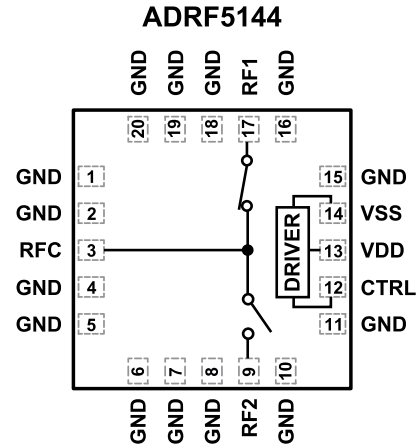

Figure 1. Functional Block Diagram

GENERAL DESCRIPTION

The ADRF5144 is a reflective, single pole double-throw (SPDT) switch manufactured in the silicon process.

The ADRF5144 operates from 1 GHz to 20 GHz with typical insertion loss of 0.8 dB and typical isolation of 52 dB. The device has a radio frequency (RF) input power handling capability of 40 dBm average power and 44 dBm peak power for the insertion loss path.

The ADRF5144 draws a low current of 130 μA on the positive supply of +3.3 V and 510 μA on negative supply of -3.3 V. The device employs complementary metal-oxide semiconductor (CMOS)/low-voltage transistor to transistor logic (LVTTL)-compatible controls. The ADRF5144 requires no additional driver circuitry, which makes it an ideal alternative to GaN and PIN diode-based switches.

The ADRF5144 can also operate with a single positive supply voltage (V_{DD}) applied while the negative supply voltage (V_{SS}) is tied to ground. In this operating condition, the small signal performance is maintained while the switching characteristics, linearity, and power handling performance are derated, see Table 2.

The ADRF5144 comes in a 20-lead, 3.0 mm × 3.0 mm, RoHS-compliant, land grid array (LGA) package and can operate from -40°C to +85°C.

TABLE OF CONTENTS

Features.....	1	Typical Performance Characteristics.....	8
Applications	1	Insertion Loss, Return Loss, And Isolation.....	8
Functional Block Diagram.....	1	Input Power Compression.....	9
General Description.....	1	Theory of Operation.....	10
Specifications.....	3	Power Supply.....	10
Single-Supply Operation.....	4	RF Input and Output.....	10
Absolute Maximum Ratings.....	5	Timing Specifications.....	10
Thermal Resistance	5	Applications Information	11
Power Derating Curves.....	5	Recommendations for PCB Design.....	11
Electrostatic Discharge (ESD) Ratings.....	6	Outline Dimensions.....	12
ESD Caution.....	6	Ordering Guide.....	12
Pin Configuration and Function Descriptions.....	7	Evaluation Boards.....	12
Interface Schematics.....	7		

REVISION HISTORY**12/2022—Revision 0: Initial Version**

SPECIFICATIONS

$V_{DD} = 3.3\text{ V}$, $V_{SS} = -3.3\text{ V}$, $V_{CTRL} = 0\text{ V}$ or V_{DD} , $T_{CASE} = 25^\circ\text{C}$, $50\ \Omega$ system, unless otherwise noted.

Table 1. Electrical Specifications

Parameter	Symbol	Test Conditions/Comments	Min	Typ	Max	Unit
FREQUENCY RANGE	f		1000		20,000	MHz
INSERTION LOSS						
Between RFC and RF1/RF2 (ON)		9 kHz to 1 GHz		0.45		dB
		1 GHz to 12 GHz		0.65		dB
		12 GHz to 20 GHz		0.8		dB
		20 GHz to 26 GHz		1.1		dB
RETURN LOSS						
RFC and RF1/RF2 (ON)		9 kHz to 1 GHz		30		dB
		1 GHz to 12 GHz		25		dB
		12 GHz to 20 GHz		20		dB
		20 GHz to 26 GHz		15		dB
ISOLATION						
Between RFC and RF1/RF2 (OFF)		9 kHz to 20 GHz		52		dB
		20 GHz to 26 GHz		47		dB
Between RF1 and RF2		9 kHz to 20 GHz		48		dB
		20 GHz to 26 GHz		43		dB
SWITCHING CHARACTERISTICS						
Rise and Fall Time	t_{RISE}, t_{FALL}	10% to 90% of RF output		135		ns
On and Off Time	t_{ON}, t_{OFF}	50% V_{CTRL} to 90% of RF output		500		ns
RF Settling Time						
0.5 dB RF Settling Time		50% V_{CTRL} to 0.5 dB of final RF output, $P_{IN} \leq 37$ dBm		550		ns
0.1 dB RF Settling Time		50% V_{CTRL} to 0.1 dB of final RF output, $P_{IN} \leq 37$ dBm		750		ns
INPUT LINEARITY		f = 1 GHz to 18 GHz				
0.1 dB Power Compression	P0.1dB			44		dBm
Input Third-Order Intercept	IIP3	Two tone input power = 30 dBm each tone, $\Delta f = 1$ MHz		>70		dBm
Input Second-Order Intercept	IIP2	Two tone input power = 30 dBm each tone, $\Delta f = 1$ MHz		>120		dBm
SUPPLY CURRENT		V_{DD}, V_{SS} pins				
Positive Supply Current	I_{DD}			130		μA
Negative Supply Current	I_{SS}			510		μA
DIGITAL CONTROL INPUTS		CTRL pin				
Voltage						
Low	V_{INL}		0		0.8	V
High	V_{INH}		1.2		3.3	V
Current						
Low and High	I_{INL}, I_{INH}			<0.1		μA
RECOMMENDED OPERATING CONDITONS						
Positive Supply Voltage	V_{DD}		3.15		3.45	V
Negative Supply Voltage	V_{SS}		-3.45		-3.15	V
Digital Control Input Voltage	V_{CTRL}		0		V_{DD}	V
RF Input Power Wait Time ¹	t_{Wait}	$P_{IN} \leq 37$ dBm	0			μs
		$37\text{ dBm} < P_{IN} \leq 41\text{ dBm}$	1.0			μs
		$41\text{ dBm} < P_{IN} \leq 42\text{ dBm}$	1.2			μs
		$42\text{ dBm} < P_{IN} \leq 43\text{ dBm}$	1.5			μs

SPECIFICATIONS

Table 1. Electrical Specifications (Continued)

Parameter	Symbol	Test Conditions/Comments	Min	Typ	Max	Unit
RF Input Power ²	P _{IN}	f = 1 GHz to 18 GHz, T _{CASE} = 85°C				
Insertion Loss Path		RF signal applied to the RFC or through connected RF1/RF2				
Average					40	dBm
Pulsed ³		>100 ns pulse width, 15% duty cycle			43	dBm
Peak		≤100 ns peak duration, 5% duty cycle			44	dBm
Hot Switching		RF signal applied to the RFC			37	dBm
Case Temperature	T _{CASE}		-40		+85	°C

¹ For more details, see the [Theory of Operation](#) section.

² For power derating over frequency, see [Figure 2](#) and [Figure 3](#).

³ For different pulsed conditions, contact [Applications Support](#).

SINGLE-SUPPLY OPERATION

V_{DD} = 3.3 V, V_{SS} = 0 V, V_{CTRL} = 0 V or V_{DD} V, T_{CASE} = 25°C, 50 Ω system, unless otherwise noted.

Table 2. Single-Supply Operational Specifications

Parameter	Symbol	Test Conditions/Comments	Min	Typ	Max	Unit	
FREQUENCY RANGE	f		1000		20,000	MHz	
SWITCHING CHARACTERISTICS							
Rise and Fall Time	t _{RISE} , t _{FALL}	10% to 90% of RF output		0.66		μs	
On and Off Time	t _{ON} , t _{OFF}	50% V _{CTRL} to 90% of RF output		1.5		μs	
0.1 dB RF Settling Time		50% V _{CTRL} to 0.1 dB of final RF output, P _{IN} ≤ 24 dBm		1.8		μs	
INPUT LINEARITY		f = 1 GHz to 18 GHz					
0.1 dB Power Compression	P0.1dB			29		dBm	
Input Third-Order Intercept	IIP3	Two tone input power = 20 dBm each tone, Δf = 1 MHz		58		dBm	
Input Second-Order Intercept	IIP2	Two tone input power = 20 dBm each tone, Δf = 1 MHz		109		dBm	
RECOMMENDED OPERATING CONDITONS							
RF Input Power Wait Time ¹	t _{Wait}	P _{IN} ≤ 24 dBm		0		μs	
		24dBm < P _{IN} ≤ 29.5dBm		2.2		μs	
RF Input Power ²	P _{IN}	f = 1 GHz to 18 GHz, T _{CASE} = 85°C					
Insertion Loss Path		RF signal applied to the RFC or through connected RF1/RF2					
Average						30	dBm
Pulsed ³		>100 ns pulse width, 15% duty cycle				30	dBm
Peak		≤100 ns peak duration, 5% duty cycle				30	dBm
Hot Switching		RF signal applied to the RFC			24	dBm	

¹ For more details, see the [Theory of Operation](#) section.

² For power derating over frequency, see [Figure 2](#) and [Figure 3](#).

³ For different pulsed conditions, contact [Applications Support](#).

ABSOLUTE MAXIMUM RATINGS

For recommended operating conditions, see [Table 1](#) and [Table 2](#).

Table 3. Absolute Maximum Ratings

Parameter	Rating
Supply Voltage	
Positive	-0.3 V to +3.6 V
Negative	-3.6 V to +0.3 V
Digital Control Input Voltage	
Voltage	-0.3 V to $V_{DD} + 0.3$ V
Current	3 mA
RF Input Power, Dual Supply ¹ ($V_{DD} = 3.3$ V, $V_{SS} = -3.3$ V, $f = 1$ GHz to 18 GHz, $T_{CASE} = 85^{\circ}\text{C}$)	
Insertion Loss Path	
Average	40.5 dBm
Pulsed	43.5 dBm
Peak	44.5 dBm
Hot Switching	37.5 dBm
RF Input Power, Single Supply ¹ ($V_{DD} = 3.3$ V, $V_{SS} = 0$ V, $f = 1$ GHz to 18 GHz, $T_{CASE} = 85^{\circ}\text{C}$)	
Insertion Loss Path	
Average	30.5 dBm
Pulsed	30.5 dBm
Peak	30.5 dBm
Hot Switching	24.5 dBm
RF Power Under Unbiased Condition ($V_{DD}, V_{SS} = 0$ V)	
Input at RFC	30 dBm
Input at RFx	24 dBm
Temperature	
Junction (T_J)	135°C
Storage	-65°C to +150°C
Reflow	260°C

¹ For power derating over frequency, see [Figure 2](#) and [Figure 3](#).

Stresses at or above those listed under Absolute Maximum Ratings may cause permanent damage to the product. This is a stress rating only; functional operation of the product at these or any other conditions above those indicated in the operational section of this specification is not implied. Operation beyond the maximum operating conditions for extended periods may affect product reliability.

Only one absolute maximum rating can be applied at a time.

THERMAL RESISTANCE

Thermal performance is directly linked to printed circuit board (PCB) design and operating environment. Careful attention to PCB thermal design is required.

θ_{JC} is the junction to the case bottom (channel to package bottom) thermal resistance.

Table 4. Thermal Resistance

Package Type	θ_{JC} ¹	Unit
CC-20-13	25	°C/W

¹ θ_{JC} was determined by simulation under the following conditions: the heat transfer is due solely to the thermal conduction from the channel through the ground pad to the PCB, and the ground pad is held constant at the operating temperature of 85°C.

POWER DERATING CURVES

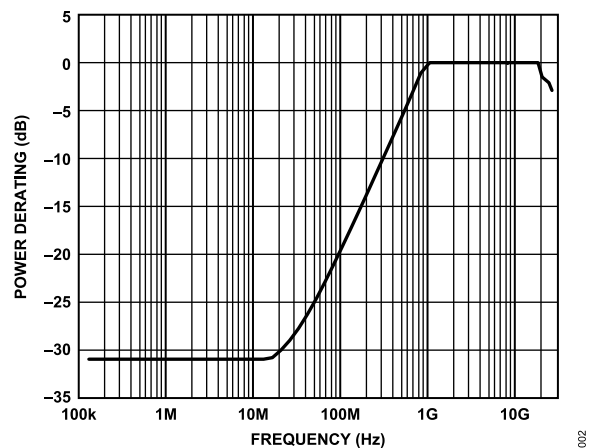

Figure 2. Power Derating vs. Frequency, Low Frequency Detail, $T_{CASE} = 85^{\circ}\text{C}$

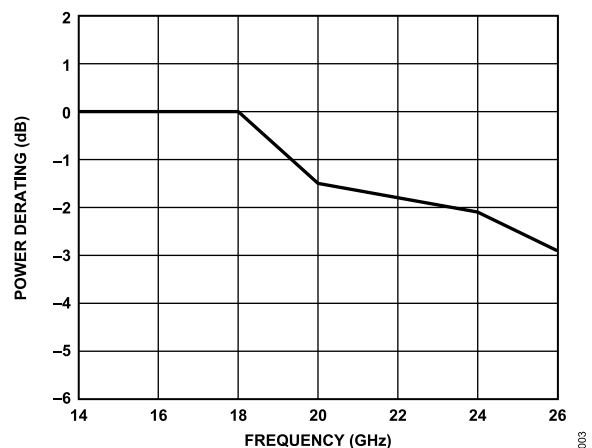

Figure 3. Power Derating vs. Frequency, High Frequency Detail, $T_{CASE} = 85^{\circ}\text{C}$

ABSOLUTE MAXIMUM RATINGS**ELECTROSTATIC DISCHARGE (ESD) RATINGS**

The following ESD information is provided for handling of ESD-sensitive devices in an ESD protected area only.

Human body model (HBM) per ANSI/ESDA/JEDEC JS-001.

Charged device model (CDM) per ANSI/ESDA/JEDEC JS-002.

ESD Ratings for ADRF5144

Table 5. ADRF5144, 20-Terminal LGA

ESD Model	Withstand Threshold (V)	Class
HBM	±2000 for all pins	2
CDM	±1250 for all pins	C3

ESD CAUTION

ESD (electrostatic discharge) sensitive device. Charged devices and circuit boards can discharge without detection. Although this product features patented or proprietary protection circuitry, damage may occur on devices subjected to high energy ESD. Therefore, proper ESD precautions should be taken to avoid performance degradation or loss of functionality.

PIN CONFIGURATION AND FUNCTION DESCRIPTIONS

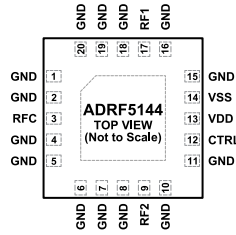

NOTES
 1. EXPOSED PAD. THE EXPOSED PAD MUST BE CONNECTED TO THE RF/DC GROUND OF THE PCB. 004

Figure 4. Pin Configuration (Top View)

Table 6. Pin Function Descriptions

Pin No.	Mnemonic	Description
1, 2, 4 to 8, 10, 11, 15, 16, 18 to 20	GND	Ground. These pins must be connected to the RF/DC ground of the PCB.
3	RFC	RF Common Port. This pin is DC-coupled to 0 V and AC matched to 50 Ω. No DC blocking capacitor is required when the RF line potential is equal to 0 V DC.
9	RF2	RF Throw Port 2. This pin is DC-coupled to 0 V and AC matched to 50 Ω. No DC blocking capacitor is required when the RF line potential is equal to 0 V DC.
12	CTRL	Control Input. For the truth table, see Table 7.
13	VDD	Positive Supply Voltage.
14	VSS	Negative Supply Voltage.
17	RF1	RF Throw Port 1. This pin is DC-coupled to 0 V and AC matched to 50 Ω. No DC blocking capacitor is required when the RF line potential is equal to 0 V DC.
	EPAD	Exposed Pad. The exposed pad must be connected to the RF/DC ground of the PCB.

INTERFACE SCHEMATICS

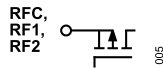

Figure 5. RF Pins (RFC, RF1, and RF2) Interface Schematic

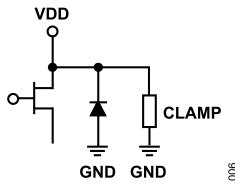

Figure 6. VDD Pin Interface Schematic

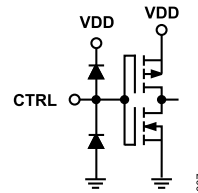

Figure 7. Digital Pin (CTRL) Interface Schematic

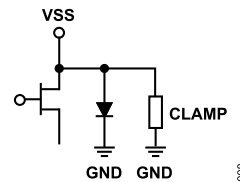

Figure 8. VSS Pin Interface Schematic

TYPICAL PERFORMANCE CHARACTERISTICS

INSERTION LOSS, RETURN LOSS, AND ISOLATION

$V_{DD} = 3.3\text{ V}$, $V_{SS} = -3.3\text{ V}$ or 0 V , $V_{CTRL} = 0\text{ V}$ or $V_{DD}\text{ V}$, and $T_{CASE} = 25^\circ\text{C}$ in a $50\ \Omega$ system, unless otherwise noted. Measured on the ADRF5144-EVALZ.

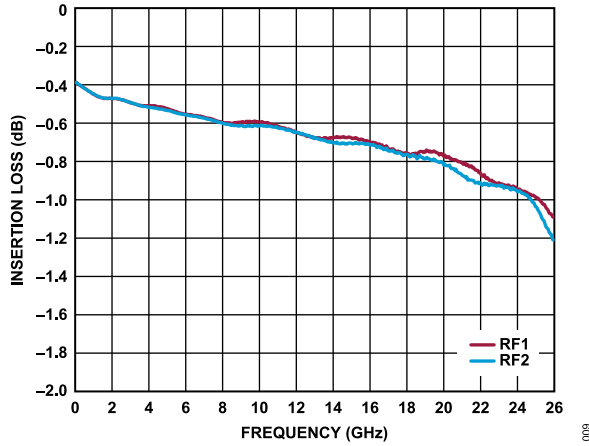

Figure 9. Insertion Loss vs. Frequency at Room Temperature for RF1 and RF2

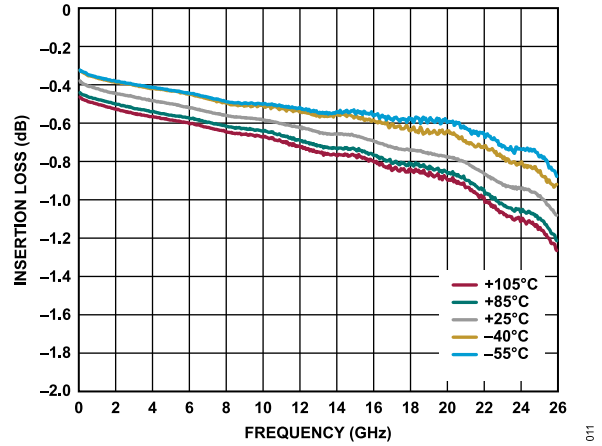

Figure 11. Insertion Loss vs. Frequency over Temperature

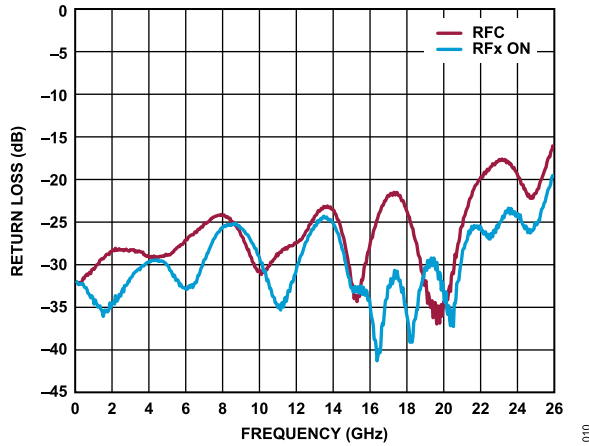

Figure 10. Return Loss vs. Frequency

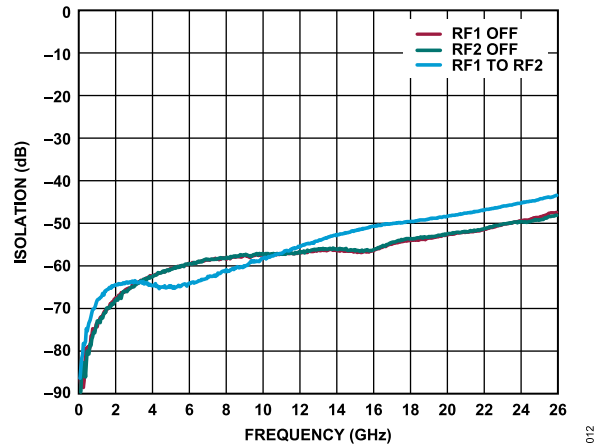

Figure 12. Isolation vs. Frequency

TYPICAL PERFORMANCE CHARACTERISTICS

INPUT POWER COMPRESSION

$V_{DD} = 3.3\text{ V}$, $V_{SS} = -3.3\text{ V}$, $V_{CTRL} = 0\text{ V}$ or $V_{DD}\text{ V}$, and $T_{CASE} = 25^\circ\text{C}$ in a $50\ \Omega$ system, unless otherwise noted. The large-signal performance parameter is measured on the [ADRF5144-EVALZ](#).

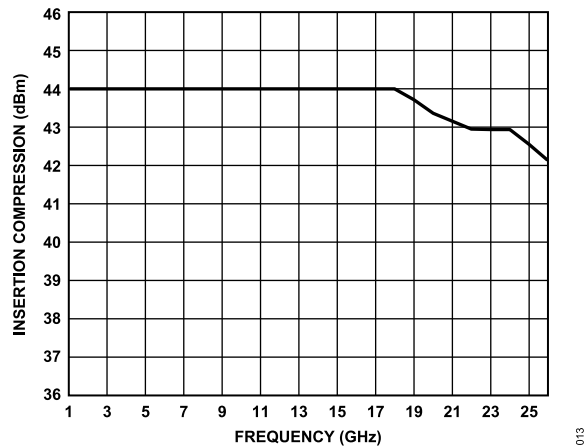

Figure 13. Input 0.1 dB Power Compression vs. Frequency

THEORY OF OPERATION

The ADRF5144 integrates a driver to perform logic function internally and to provide the advantage of a simplified control interface. The driver features a single control input pin, CTRL, that controls the state of RF paths, determining which RF port is in insertion loss state and which RF port is in isolation state (see Table 7).

POWER SUPPLY

The ADRF5144 requires a positive supply voltage applied to the VDD pin and a negative supply voltage applied to the VSS pin. Bypassing capacitors are recommended on the supply lines to minimize RF coupling.

The ideal power-up sequence is as follows:

1. Connect the ground.
2. Power up VDD and VSS. Power up VSS after VDD to avoid current transients on VDD during ramp-up.
3. Power up the digital control inputs. Power the digital control inputs before the VDD supply can inadvertently forward bias and damage the internal ESD protection structures. To avoid this damage, use a series 1 kΩ resistor to limit the current flowing into the control pin. Use pull-up or pull-down resistors if the controller output is in a high-impedance state after VDD is powered up, and the control pins are not driven to a valid logic state.
4. Apply an RF input signal.
5. The ideal power-down sequence is the reverse order of the power-up sequence.

Single-Supply Operation

The ADRF5144 can operate with a single positive supply voltage applied to the VDD pin and VSS pin connected to the ground. However, some performance difference can occur in switching characteristics and large signal. For more details, see Table 2.

RF INPUT AND OUTPUT

All of the RF ports (RFC, RF1, and RF2) are DC-coupled to 0 V, and no DC blocking is required at the RF ports when the RF line potential is equal to 0 V.

The RF ports are internally matched to 50 Ω. Therefore, external matching networks are not required.

The insertion loss path conducts the RF signal between the selected RF throw port and the RF common port. The isolation path provides high loss between the insertion loss path and the unselected RF throw port. The unselected RF port of the ADRF5144 is reflective.

The switch design is bidirectional with equal power handling capabilities. The RF input signal can be applied to the RFC port or the selected RF throw port.

Table 7. Control Voltage Truth Table

Digital Control Input, V _{CTRL}	RF Paths	
	RF1 to RFC	RF2 to RFC
Low	Insertion loss (on)	Isolation (off)
High	Isolation (off)	Insertion loss (on)

TIMING SPECIFICATIONS

When RF input power is greater than the maximum recommended hot-switching power level, a wait time of t_{WAIT} has to be respected after switching between RF throw ports, see Figure 14.

There is no wait time required if applying RF power levels lower than or equal to the maximum recommended hot-switching power level, see Table 1 and Table 2.

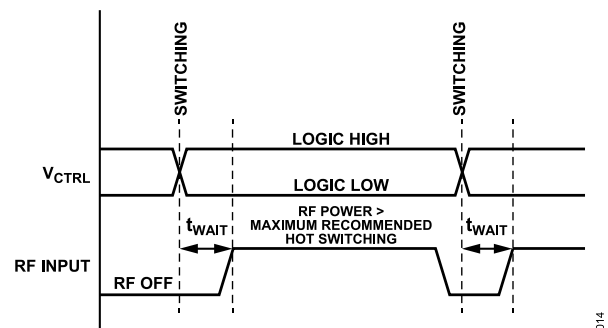

Figure 14. RF Input Power Wait Time

APPLICATIONS INFORMATION

The ADRF5144 has two power supply pins (VDD and VSS) and one control pin (CTRL). Figure 15 shows the external components and connections for supply and control pins. The VDD pin and the VSS pin are decoupled with 100 pF and 10 nF multilayer ceramic capacitor, while the control pin is decoupled with 100 pF multilayer ceramic capacitor. The device pin out allows the placement of the decoupling capacitors close to the device. No other external components are needed for bias and operation, except DC blocking capacitors on the RF pins when the RF lines are biased at a voltage different than 0 V. For more details, see the Pin Configuration and Function Descriptions section.

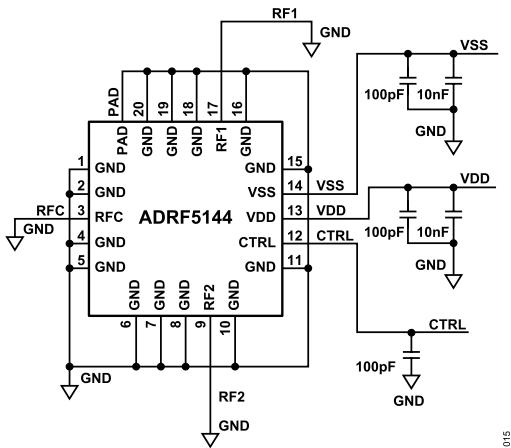

Figure 15. Recommended Schematic

RECOMMENDATIONS FOR PCB DESIGN

The RF ports are matched to 50 Ω internally and the pin out is designed to mate a coplanar waveguide (CPWG) with 50 Ω characteristic impedance on the PCB. Figure 16 shows the referenced CPWG RF trace design for an RF substrate with 8 mil thick Rogers RO4003 dielectric material. RF trace with 14 mil width and 7 mil clearance is recommended for 1.5 mil finished copper thickness.

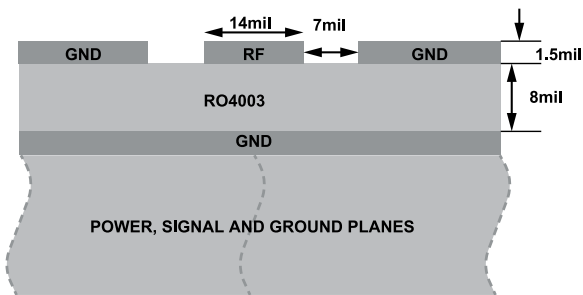

Figure 16. Example PCB Stack Up

Figure 17 shows the routing of the RF traces, supply, and control signals from the device. The ground planes are connected with as many filled, through vias as allowed for optimal RF, and thermal performance. The primary thermal path for the device is the bottom side, therefore a heatsink is required underneath the PCB to ensure maximum heat dissipation and to reduce thermal rise on the PCB during high-power applications.

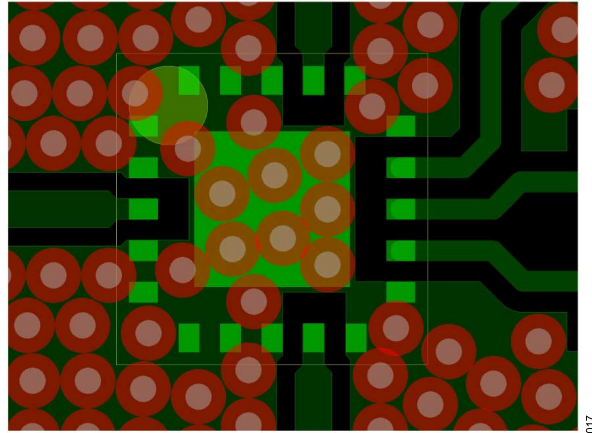

Figure 17. PCB Routings

Figure 18 shows the recommended layout from the device RF pins to the 50 ohm CPWG on the referenced stack-up. PCB pads are drawn 1:1 to device pads. The ground pads are drawn soldermask defined and the signal pads are drawn as pad defined. The RF trace from the PCB pad is extended with the same width till the package edge and tapered to RF trace with 45° angle. The paste mask is also designed to match the pad without any aperture reduction. The paste is divided into multiple openings for the paddle.

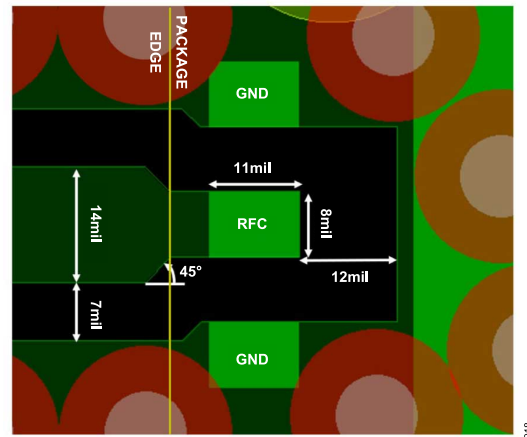
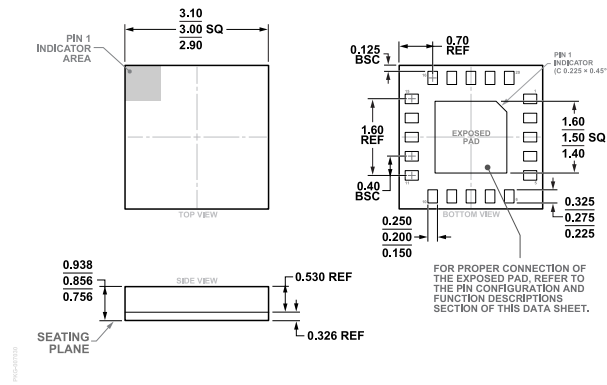

Figure 18. Recommended RF Pin Transitions

For alternate PCB stack-ups with different dielectric thickness and CPWG design, and for further recommendations, contact Analog Devices, Inc., Technical Support Request.

OUTLINE DIMENSIONS



**Figure 19. 20-Terminal Land Grid Array [LGA]
3.0 mm x 3.0 mm Body and 0.856 mm Package Height
(CC-20-13)
Dimensions Shown in millimeters**

ORDERING GUIDE

Model ¹	Temperature Range	Package Description	Package Quantity	Package Option
ADRF5144BCCZN	-40°C to +85°C	20-Terminal Land Grid Array [LGA]	Reel, 500	CC-20-13
ADRF5144BCCZN-R7	-40°C to +85°C	20-Terminal Land Grid Array [LGA]	Reel, 500	CC-20-13

¹ Z = RoHS-Compliant Part.

EVALUATION BOARDS

Table 8. Evaluation Boards

Model ¹	Description
ADRF5144-EVALZ	Evaluation Board

¹ Z = RoHS-Compliant Part.

Looking for pricing, stock, or lifecycle information?

Click below to explore more details on WIN SOURCE:

 [View ADRF5144BCCZN on WIN SOURCE](#)

 [Analog Devices Inc. Information](#)

Optimize Your Supply Chain with WIN SOURCE Solutions

-  Global Sourcing Solution
-  Obsolete Management
-  Cost Control Management
-  Shortage Management
-  Alternative Solution
-  Excess Inventory Management